

**PADERNO®**

WORLD CUISINE

[WWW.PADERNO.IT](http://WWW.PADERNO.IT)

CATALOGUE **2022**

PARTNER OF THE BEST CUISINE





Alfredo Russo

COVER  
MICHELIN-STARRED CHEF ALFREDO RUSSO

DOLCE STIL NOVO ALLA REGGIA - VENARIA REALE





## MADE TO SHINE

Paderno has always been by professionals' side, so that the "star" in each of them can finally "shine". This is the philosophy behind the new brand communication campaign, a fascinating storytelling made of competence and passion where – in the spotlight – the excellence of Paderno's product range cannot miss.

Every day in the kitchen is a challenge, in which you have to manage space, time and tools. Paderno Made to Shine reveals the magic of those moments, with a flawless cooking performance by a Michelin-starred chef or with the show by a flair bartender during a mixology event. Discover all the contents on the website and social media, share them and join the Paderno community.

Professionals at the service of professionals.

LADIES AND GENTLEMEN,  
LET THE SHOW BEGINS!

Paderno è da sempre al fianco di tutti professionisti, affinché la "stella" presente in ciascuno di loro possa finalmente "splendere". Questa la filosofia dalla quale prende vita la nuova campagna di comunicazione del marchio, un affascinante storytelling di competenza e passione dove – sotto i riflettori – non può mancare l'eccellenza della gamma prodotti Paderno.

In cucina ogni giorno è una sfida, nella quale occorre gestire spazi, tempi e strumenti. Paderno Made to Shine svela la magia di quei momenti, dalla rigorosa performance ai fornelli di uno chef stellato, allo spettacolare show di un barman acrobatico durante un evento mixology. Scoprite tutti i contenuti sul sito e sui canali social, condivideteli ed entrate nella community Paderno.

Professionisti al servizio dei professionisti.

SIGNORE E SIGNORI,  
HA INIZIO LO SPETTACOLO!

## VIDEO PERFORMANCE



[www.paderno.it](http://www.paderno.it)



# Factory

**A COMPLETE RANGE FOR EVERY NEED IN THE KITCHEN.  
MORE THAN 10.000 ITEMS DEDICATED TO CHEFS AND  
PASSIONATE GOURMANDS.**

From the cookware to the kitchen utensils, then knives, bakery items and tools for every kind of preparation, Paderno offers a complete selection for the best kitchens of houses and restaurants. A brand that finds its origins back in 1925 in Milan as "Alluminio Paderno", specializing in household cookware before it decided to focus on the professional cooking world. With over 90 years of history and a strong worldwide presence, Paderno is the premier choice for professionals in the catering sector. In addition to the production items, the brand offers a remarkable range of complementary articles, carefully selected and crafted by highly qualified companies.

**UNA GAMMA COMPLETA PER OGNI ESIGENZA IN CUCINA.  
OLTRE 10.000 ARTICOLI COMPONGONO L'OFFERTA  
DEDICATA A CHEF E APPASSIONATI GOURMET.**

Dal pentolame agli utensili cucina, passando per coltelli, articoli da pasticceria e strumenti per ogni tipo di preparazione, Paderno offre una selezione completa per le migliori cucine di case e ristoranti. Il Brand trova le sue origini nel 1925 nei pressi di Milano come Alluminio Paderno, specializzato nel settore della cucina casalinga per poi passare al settore professionale. Forte di oltre 90 anni di storia e di una presenza capillare in tutto il mondo, Paderno è il punto di riferimento per tutti i professionisti della ristorazione. Agli articoli di produzione il brand affianca un'importante gamma di prodotti complementari e affini, accuratamente selezionati e realizzati da ditte altamente qualificate.



## **Ho.Re.Ca.**

T 0321 19 16 601  
F 0321 19 16 890

[horeca@paderno.it](mailto:horeca@paderno.it)  
[horeca@sambonet.it](mailto:horeca@sambonet.it)

## **Retail**

T 0321 19 16 701  
F 0321 19 16 830

[retail.italia@sambonet.it](mailto:retail.italia@sambonet.it)  
[retail.international@sambonet.it](mailto:retail.international@sambonet.it)

## **Return**

T 0321 19 16 635 - 759

[returns@sambonet.it](mailto:returns@sambonet.it)

[www.paderno.it](http://www.paderno.it)





# Green & Human

The respect for the environment and for the people is a relevant issue for Sambonet Paderno Industrie S.p.A. Corporate Responsibility. The commitment to sustainable growth on which the Group was founded has been maintained and permits both to guarantee adequate working conditions in order to satisfy the changing needs of the staff and to apply solutions aimed at reducing the environmental impact. From this perspective, the management of energy, electricity and water consumption focuses on:

- the use of electrical energy: clean, renewable and in harmony with the environment;
- the use of methane as the sole fuel source;
- the use of ground water for the manufacturing process, to be fully purified before being released into the environment;
- the use of an advanced energy-saving technology.

## Sustainability Report

Sambonet Paderno Industrie S.p.A. strives to implement forms of measurement to assess the punctuality, the transparency and the efforts made for sustainable development. This has led to the preparation of the corporate charter of principles, 10 principles, 10 commitments, on which the Company builds its industrial future from a perspective based on preventive approach and stewardship.

### Corporate Sustainability Report

[corporate.sambonet.it/csr.html](http://corporate.sambonet.it/csr.html)

The **UNI EN ISO 14001:2004** environmental certification is the recognition that the environmental policy results in a continuous improvement of environmental performance by minimising the negative impact of its operations on the environment.

The voluntary compliance with the standard **UNI EN ISO 50001:2011** demonstrates the company's commitment and vision towards responsible energy consumption, factoring in both the economic hope of reducing consumption and, above all, the desire to increase environmental awareness about reducing greenhouse gas emissions.

The **OHSAS 18001:2007** safety certification has the objective of protecting the safety of the workplace and the health of workers. Sambonet Paderno Industrie S.p.A. is the first Italian company in its sector that has obtained this certification.

## Social Responsibility

Sustainability, transparency and interaction with stakeholders are the integral components that the Corporate Social Responsibility policy of Sambonet Paderno Industries S.p.A. are comprised of.

The company's requirements, commitment and path taken in this area led it to obtain an SR10 certification in 2016 - the first in the sector. This important goal represents an objective guarantee in terms of attention in the interaction with stakeholders such as employees, customers, suppliers, local communities and associations in the area.

## WHP Health Promoting Workplace

This socially responsible role has recently prompted the company to join the European Network for Health Promoting Workplace (WHP), establishing itself as one of the pioneers of its territory. The project foresees that the company not only implements all the measures to prevent accidents and illnesses in the workplace but - and above all - that it also undertakes to offer its workers opportunities to improve their health, through the promotion of a wholesome lifestyle mentally, physically and emotionally.

Il rispetto dell'ambiente e della persona sono temi rilevanti all'interno della responsabilità d'impresa di Sambonet Paderno Industrie S.p.A. Il Gruppo ha impostato e sviluppa tutt'oggi la propria evoluzione con un impegno di crescita sostenibile garantendo condizioni lavorative che possano soddisfare i bisogni delle persone nei differenti momenti della loro vita aziendale e applicando soluzioni volte a diminuire l'impronta ecologica. In quest'ottica, la gestione dei consumi energetici, elettrici e idrici è orientata a:

- impiegare energia elettrica pulita e rinnovabile;
- utilizzare il metano come unica fonte di combustibile;
- servirsi, per la produzione, di acqua di falda da restituire all'ambiente completamente depurata;
- usare tecnologia di risparmio energetico avanzata.

Sambonet Paderno Industrie S.p.A. lavora per attuare forme di misurazione che siano in grado di documentare la puntualità, la trasparenza e l'impegno messo in atto per uno sviluppo sostenibile. Da qui la creazione della propria carta dei principi, 10 principi, 10 impegni su cui, attraverso un approccio preventivo e una gestione responsabile, l'Azienda costruisce il proprio futuro industriale.

### Bilancio di Sostenibilità dell'Azienda

[corporate.sambonet.it/csr.html](http://corporate.sambonet.it/csr.html)

**UNI EN ISO 14001:2004** La certificazione ambientale garantisce i risultati di una politica ambientale volta al continuo miglioramento delle proprie performance minimizzando ogni impatto negativo delle sue attività verso l'ambiente.

**UNI EN ISO 50001:2011** L'adesione volontaria alla norma UNI EN ISO 50001:2011 testimonia l'impegno e la visione dell'azienda verso l'ottimizzazione del consumo responsabile dell'energia, sia in termini economici auspicando a una riduzione dei consumi, e soprattutto verso una crescente attenzione ambientale diminuendo le emissioni di gas serra.

**OHSAS 18001:2007** La certificazione ha l'obiettivo di tutelare la sicurezza e la salute dei propri lavoratori e dell'ambiente lavorativo. Sambonet Paderno Industrie S.p.A. è la prima Azienda appartenente al settore metalmeccanico ad ottenere l'attestazione.

Sostenibilità, trasparenza e interazione con gli stakeholder sono le parole chiave della politica di Corporate Social Responsibility di Sambonet Paderno Industrie S.p.A..

I requisiti, l'impegno e il percorso intrapreso dall'azienda in questo ambito, l'ha portata nel 2016 - prima nel settore - a conseguire la certificazione SR10. Questo importante traguardo rappresenta una garanzia oggettiva in fatto di attenzione nell'interazione con gli stakeholder quali dipendenti, clienti, fornitori, comunità locali e associazioni sul territorio.

Questo ruolo socialmente responsabile ha recentemente spinto l'impresa ad aderire alla Rete Europea WHP (European Network for Health Promoting Workplace) affermandosi tra le pioniere del proprio territorio. Il progetto prevede che l'azienda non solo attui tutte le misure per prevenire infortuni e malattie sul luogo di lavoro ma - e soprattutto - che si impegni anche a offrire ai propri lavoratori opportunità per migliorare la propria salute, attraverso la promozione di uno stile di vita corretto in ambito alimentare, sportivo ed emotivo.

# Certifications

## UNI EN ISO 22000

Sambonet Paderno Industrie is the first company in its industry that has been awarded the EN UNI ISO 22000:2005 certification. This certification attests to the highest international standard both for the Group and for the whole food and beverage industry. The implementation of HACCP (Hazard Analysis and Critical Control Points, a hygiene system that prevents contamination hazards), ensures the provision of a safe and impeccable service to customers by meticulously and scrupulously assessing the hygienic and safety conditions of activities and products. This is a guarantee not only for HoReCa professionals, but also, and foremost, for final consumers.

## UNI EN ISO 9001:2015

This quality certification ensures compliance with the requirements of the international UNI EN ISO 9001:2008 standard, which guarantees the production and sale of products that fully meet customers' needs and expectations.

## NSF

Some products by Sambonet Paderno Industrie S.p.A. have obtained the prestigious NSF (National Sanitation Foundation) certification for compliance with the strict standards applied in the USA to materials in contact with foodstuffs. The NSF mark is a guarantee for manufacturers, inspectors and users.

## AEO

In 2008 Sambonet Paderno Industrie S.p.A. obtained the AEO Certification for Customs Simplifications and Security and Safety, valid for the EU. This programme provides a framework for governing customs regulations, guaranteeing that the company provides a reliable and secure service within the international supply chain. In addition, in 2011, Sambonet Paderno Industrie S.p.A. obtained the mutual recognition of the AEO programme with the Japanese customs administration, thus further improving customs relations with Japan.

## KNOWN CONSIGNOR

The "Known Consignor" approval issued by ENAC (Italian Civil Aviation Authority) certifies that the company is an originator of cargo suitable for carriage on any aircraft, in compliance with common safety procedures and provisions.

## ECCELLENZA 2006

This prestigious certificate of Excellence, awarded by Certiquality to Sambonet Paderno Industrie S.p.A. for the implementation of an integrated Quality, Environmental and Safety management system, has been granted only to few companies in Italy that have obtained the ISO 9001, ISO 14001 and BS OHSAS 18001 certifications.

## AWARD FOR EXCELLENCE

In 2006 Sambonet Paderno Industrie S.p.A. received the Award for Excellence for Innovation by Confindustria (the main organization representing Italian manufacturing and services companies) with reference to the framework for innovation of the EFQM—European Foundation for Quality Management.

## UNI EN ISO 22000

Prima nel suo settore Sambonet Paderno Industrie S.p.A. ha ottenuto la certificazione EN UNI ISO 22000:2005. Così come per l'intero comparto food and beverage, anche per il Gruppo la UNI EN ISO 22000:2005 rappresenta lo standard di più alto livello su scala internazionale. L'applicazione dei suoi requisiti, congiuntamente all'applicazione dell'HACCP (Hazard Analysis and Critical Control Points, sistema di autocontrollo igienico che previene i pericoli di contaminazione), garantisce alla clientela un servizio sicuro ed impeccabile attraverso una valutazione puntuale e scrupolosa delle condizioni igieniche e sanitarie delle attività e dei prodotti. Una garanzia di tutela non solo per il personale del canale professionale ma anche, e soprattutto, per il consumatore finale.

## UNI EN ISO 9001:2015

La certificazione di qualità conforme ai requisiti della normativa internazionale garantisce la produzione e la commercializzazione di prodotti che soddisfino pienamente i requisiti e le aspettative del cliente.

## NSF

La certificazione è stata conseguita per alcuni prodotti grazie al superamento delle rigorose norme applicate negli USA circa i materiali a contatto con gli alimenti. Il marchio NSF (National Sanitation Foundation) è sinonimo di garanzia per i costruttori, ispettori ed utilizzatori.

## AEO

La certificazione comunitaria AEO Semplificazioni doganali e Sicurezza, conseguita nel 2008, garantisce un'attività disciplinata della regolamentazione doganale dell'azienda qualificandola in fatto di affidabilità e sicurezza nella catena di approvvigionamento internazionale. Nel 2011, inoltre, Sambonet Paderno Industrie S.p.A. ha ottenuto il mutuo riconoscimento del programma AEO con l'amministrazione doganale giapponese, condizione che favorisce ulteriormente i rapporti con il paese.

## MITTENTE CONOSCIUTO

L'approvazione "Mittente Conosciuto" rilasciata da ENAC (Ente Nazionale Aviazione Civile) riconosce l'Azienda come sito d'origine di merce idonea al trasporto su aeromobili di qualsiasi tipo, in conformità alle procedure e disposizioni comuni di sicurezza.

## ECCELLENZA 2006

Certiquality ha attribuito a Sambonet Paderno Industrie S.p.A. il Certificato di Eccellenza per aver implementato un sistema di gestione integrata di Qualità, Ambiente e Sicurezza. L'ambito riconoscimento è ottenuto da poche aziende in Italia certificate ISO 9001, ISO 14001 e BS OHSAS 18001.

## AWARD FOR EXCELLENCE

Nel 2006 Sambonet Paderno Industrie S.p.A. è stata insignita dell'Award for Excellence per l'innovazione, rilasciato da Confindustria in riferimento al framework per l'innovazione dell'EFQM—European Foundation for Quality Management.





# ASEC<sup>LAB</sup>

ALIMENTARY  
SECURITY  
CONTROL  
LABORATORY



ASECLAB1@SAMBONET.IT



LABORATORIO DI ANALISI  
INTERNO CERTIFICATO



LAB N°1407

The items produced and sold by Sambonet Paderno Industrie S.p.A. not only comply with applicable regulations, but are also systematically tested. The Company can guarantee the suitability and safety of its products as it has established a specific workgroup and the ASEC Lab (Alimentary Security Control) internal laboratory, which analyses the materials intended to come into contact with foodstuffs. The laboratory is now accredited to carry out migration testing on steel, aluminum, porcelain, glass, entirely plastic materials and coloring in order to issue declarations of compliance, recognized by both national and international governments. The ASEC Lab is also accredited to determine pH levels, solvents and metals in water discharge, a guarantee for the internal analysis of the wastewater quality.

Oltre alla conformità rispetto alle norme vigenti, gli articoli prodotti e commercializzati da Sambonet Paderno Industrie S.p.A. sono controllati in maniera sistematica. Grazie alla costituzione di un gruppo di lavoro e del laboratorio interno ASEC Lab (Alimentary Security Control), specializzato nell'analisi di materiali destinati al contatto con gli alimenti, l'Azienda è in grado di garantire l'idoneità e la sicurezza dei propri prodotti. Il laboratorio è oggi accreditato per realizzare internamente test di migrazione su acciaio, alluminio, porcellana, vetro, materiali plastici e coloranti per il rilascio di dichiarazioni di conformità, riconosciute da qualsiasi ente nazionale e internazionale. ASEC Lab è inoltre accreditato per la determinazione di pH, solventi e metalli nelle acque scarico, una garanzia per le analisi interne sulla qualità delle proprie acque di scarico.



Pentolame  
Cookware, pots & pans  
Kochgeschirr  
Batteries de cuisine  
Baterías de cocina

## 10



GN food pans  
Contentori GN  
GN-Behälter  
Bacs GN  
Cubetas GN

## 51



Kitchen utensils  
Utensili da cucina  
Küchenzubehöre  
Ustensiles de cuisine  
Utensilios de cocina

## 78



Knives  
Coltelleria  
Kochmesser  
Coutellerie  
Cuchilleria

## 136



Pastry utensils  
Pasticceria  
Konditorei-Artikel  
La pâtisserie  
Pastelería

## 168



Ethnic cuisine  
Cucina etnica  
Ethnische Küche  
Cuisine ethnique  
Cocina étnica

## 249





Bar & Ice-Cream  
Bar e gelateria  
Bar u. Eis-Artikel  
Bar et glace  
Bar y heladería

## 275



Table top service  
Tavola  
Tischservice  
Service de table  
Servicio de mesa

## 339



Buffet display and presentation  
Buffet e presentazione  
Buffet und Präsentation  
Buffet et présentation  
Presentación de buffet

## 401



Chafing dishes / Trolleys  
Scaldavivande / Carrelli sala  
Chafing dishes / Servicewagen  
Chafing dishes / Chariots  
Chafing dishes / Carros

## 440



Storage, transport, cleaning  
Stoccaggio, trasporto, pulizia  
Lagerung, Transport, Reinigung  
Stockage, transport, nettoyage  
Almacenamiento, transporte, limpieza

## 465



Electric appliances  
Apparecchi elettrici  
Elektrogeräte  
Appareils électriques  
Aparatos eléctricos

## 495

















## ICONS - SIMBOLOGIA - SYMBOLE - SYMBOLES - ICONOS

|                           |   |                           |   |
|---------------------------|---|---------------------------|---|
| <b>ABS</b>                | Copolymer, acrylonitrile-butadiene-styrene<br>Copolimero, acrilonitrile-butadiene-stirene | <b>PA+</b><br><i>plus</i> | Polyamide (nylon 6.6) with fiberglass<br>Poliammide (nylon 6.6) con fibra di vetro    |
| <b>AG</b>                 | Silverplated<br>Argentato   | <b>PR</b>                 | Porcelain<br>Porcellana   |
| <b>AQ</b><br><b>PVD</b>   | Antique PVD   | <b>PC</b>                 | Polycarbonate<br>Policarbonato  |
| <b>AR</b>                 | Natural slate<br>Ardesia naturale   | <b>PE</b>                 | Polyethylene<br>Polietilene   |
| <b>AY</b>                 | Acrylic<br>Acrilico   | <b>PMMA</b>               | Polymethylmethacrylate, plexiglass<br>Polimetilmetacrilato, plexiglas                 |
| <b>B</b>                  | Bamboo  | <b>PPE</b>                | Phenylene ether-expanded polypropylene<br>Etere di polifenilene-polipropilene espanso |
| <b>BC</b>                 | Bone china  | <b>PP</b>                 | Polypropylene<br>Polipropilene  |
| <b>BPA</b><br><b>FREE</b> | Without bisphenol A<br>Senza bisfenolo A  | <b>PS</b>                 | Polystyrene<br>Polistirene/polistirolo  |
| <b>FE</b>                 | Metal<br>Metallo  | <b>PVD</b>                | Physical vapor deposition<br>Deposizione fisica da vapore                             |
| <b>HDPE</b>               | High-density polyethylene<br>Polietilene ad alta densità                                  | <b>R</b>                  | Natural rattan<br>Rattan naturale   |
| <b>MF</b>                 | Melamine<br>Melamina  | <b>SAN</b>                | Acrylonitrile-styrene copolymer<br>Copolimero acrilonitrile-stirene                   |
| <b>MS</b>                 | Methylstyrene<br>Metilstirene   | <b>SMMA</b>               | Styrene Methyl Methacrylate<br>Stirene-metilmetacrilato                               |
| <b>NEW</b>                | New<br>Novità   | <b>SS</b>                 | Stainless steel<br>Acciaio inox   |
| <b>NSF</b>                | NSF certified<br>Certificato NSF  | <b>VG</b>                 | Vintage   |
| <b>PA</b>                 | Polyamide (nylon)<br>Poliammide (nylon)   | <b>VG</b><br><b>PVD</b>   | Vintage PVD   |
|                           |   | <b>W</b>                  | Wood<br>Legno   |



# ICONS - SIMBOLOGIA - SYMBOLE - SYMBOLES - ICONOS

|   |   |   |  |
|---|---|---|--|
|    | Suitable for electric stoves<br>Adatto per fornelli elettrici             |    | GN size<br>Misure GN   |
|    | Suitable for glass-ceramic stoves<br>Adatto per fornelli in vitroceramica |    | Battery powered<br>Alimentato a batterie                     |
|    | Suitable for induction stoves<br>Adatto per fornelli a induzione          |    | Hand wash<br>Lavare a mano                                   |
|    | Suitable for gas stoves<br>Adatto per fornelli a gas                      |    | Do not use sharp objects<br>Non usare oggetti taglienti      |
|    | For gluten free food<br>Per alimenti senza glutine                        |    | Do not use on open flames<br>Non utilizzare su fiamme libere |
|    | Cooling<br>Refrigerabile  |    | Dishwasher safe<br>Lavabile in lavastoviglie                 |
|    | Heated<br>Riscaldato  |    | No dishwasher safe<br>Non lavabile in lavastoviglie          |
|    | Water resistant<br>Resistente all'acqua                                   |    | Microwave safe<br>Idoneo a microonde                         |
|  | NO water resistant<br>NON resistente all'acqua                            |  | Oven safe<br>Idoneo a forno                                  |
|  | With light<br>Con luce  |  | No microwave safe<br>Non idoneo a microonde                  |
|  | Food safe<br>Per alimenti   |  | No oven safe<br>Non idoneo a forno                           |
|  | Stackable<br>Impilabile   |   |  |

Product list # Gluten Free - Spare parts  
Elenco prodotti Gluten Free - Ricambi  
Glutenfrei-Produktliste - Ersatzteile  
Liste produits Gluten Free - Pièces de rechange  
Lista productos Gluten Free - Repuestos

## 518



Index and sales terms  
Indice e condizioni di vendita  
Index und Verkaufsbedingungen  
Index et conditions de vente  
Índice y condiciones de venta

## 533





# SERIES 1100

STAINLESS STEEL COOKWARE  
PENTOLAME INOX



Outside and inside satin polished. Top edges mirror polished. Hollow tubular stay cool handles in stainless steel, ergonomically shaped. Extra thick edges. Double thick bottom. Sandwich thermoradiant bottom (stainless steel-aluminum-stainless steel). Concave bottom when cold and flat when hot (100% heat exploiting). Perfect for use on any type of stove, whether gas, electric, glass ceramic cooking surface or induction stove. All items have an induction suited sandwich bottom.

Finitura esterna ed interna satinata, bordo lucido. Manicatura tubolare in acciaio inox, anatomica, resistente al calore. Bordo rinforzato. Doppio spessore del fondo. Fondo termodiffusore sandwich (inox-alluminio-inox). Concavo a freddo e piano a caldo (sfruttamento del calore al 100%). Ideali per ogni tipo di cottura, gas, elettrica, vetroceramica e induzione. Tutti gli articoli sono dotati di speciale fondo termodiffusore adatto anche per piastre ad induzione.





**Stock pot**  
Pentola  
Hoher Suppentopf  
Marmite traiteur  
Olla recta

| art.     | Ø cm. | h. | lt.   |
|----------|-------|----|-------|
| 11101-16 | 16    | 16 | 3,2   |
| 11101-20 | 20    | 20 | 6,2   |
| 11101-24 | 24    | 24 | 10,0  |
| 11101-28 | 28    | 28 | 16,5  |
| 11101-32 | 32    | 32 | 24,0  |
| 11101-36 | 36    | 36 | 36,0  |
| 11101-40 | 40    | 40 | 50,0  |
| 11101-45 | 45    | 45 | 70,0  |
| 11101-50 | 50    | 50 | 100,0 |



**Low stock pot**  
Pentola bassa  
Gemüsetopf  
Faitout  
Olla recta baja

| art.     | Ø cm. | h. | lt.  |
|----------|-------|----|------|
| 11105-16 | 16    | 14 | 2,7  |
| 11105-20 | 20    | 17 | 5,0  |
| 11105-24 | 24    | 21 | 8,5  |
| 11105-28 | 28    | 23 | 14,5 |
| 11105-32 | 32    | 26 | 22,0 |
| 11105-36 | 36    | 28 | 29,0 |
| 11105-40 | 40    | 32 | 40,0 |



**Saucepot**  
Casseruola alta  
Fleischtopf  
Brasière  
Cacerola alta

| art.     | Ø cm. | h.   | lt.  |
|----------|-------|------|------|
| 11107-16 | 16    | 11,0 | 2,1  |
| 11107-20 | 20    | 13,0 | 4,0  |
| 11107-24 | 24    | 15,0 | 6,5  |
| 11107-28 | 28    | 17,5 | 10,8 |
| 11107-32 | 32    | 19,5 | 15,7 |
| 11107-36 | 36    | 21,5 | 22,0 |
| 11107-40 | 40    | 24,5 | 30,8 |
| 11107-45 | 45    | 27,5 | 44,0 |
| 11107-50 | 50    | 32,0 | 63,0 |



**Casserole pot**  
Casseruola bassa  
Bratentopf  
Sautoir  
Cacerola baja

| art.     | Ø cm. | h.   | lt.  |
|----------|-------|------|------|
| 11109-16 | 16    | 7,5  | 1,3  |
| 11109-20 | 20    | 8,0  | 2,5  |
| 11109-24 | 24    | 9,5  | 4,3  |
| 11109-28 | 28    | 11,0 | 6,7  |
| 11109-32 | 32    | 12,5 | 10,0 |
| 11109-36 | 36    | 14,0 | 14,2 |
| 11109-40 | 40    | 15,5 | 19,5 |
| 11109-45 | 45    | 17,0 | 27,0 |
| 11109-50 | 50    | 19,0 | 37,0 |



**Colander for stock pot**  
Colapasta per pentola  
Seiher für Suppentopf  
Passoire pour marmite  
Colador para olla recta

| art.     | Ø cm. | h.   |
|----------|-------|------|
| 11123-20 | 20    | 22,0 |
| 11123-24 | 24    | 26,5 |
| 11123-28 | 28    | 29,5 |

Suitable for both item 11105 and 11101.  
Per art. 11105 e art. 11101.



**Stock pot with tap**  
Pentola con rubinetto  
Hochtopf mit Hahn  
Marmite avec robinet  
Olla con grifo

| art.     | Ø cm. | h. | lt.   |
|----------|-------|----|-------|
| 11102-28 | 28    | 28 | 16,5  |
| 11102-32 | 32    | 32 | 24,0  |
| 11102-36 | 36    | 36 | 36,0  |
| 11102-40 | 40    | 40 | 50,0  |
| 11102-45 | 45    | 45 | 70,0  |
| 11102-50 | 50    | 50 | 100,0 |



**Steamer pot, perforated bottom**  
Inserto a vapore, fondo forato  
Dampf-Siebeinsatz  
Casserole à vapeur, perforée  
Cacerola base perforada

| art.     | Ø cm. | h.   |
|----------|-------|------|
| 11119-20 | 20    | 12,5 |
| 11119-24 | 24    | 15,0 |
| 11119-28 | 28    | 17,0 |
| 11119-32 | 32    | 19,0 |



11161

11119

11105



**Saucepan**  
Casseruola alta  
Stielkasserolle, hoch  
Casserole haute  
Cazo recto alto

| art.      | Ø cm. | h.   | lt.  |
|-----------|-------|------|------|
| 11106-14  | 14    | 8,0  | 1,2  |
| 11106-16  | 16    | 11,0 | 2,1  |
| 11106-20  | 20    | 13,0 | 4,0  |
| 11106-24  | 24    | 15,0 | 6,5  |
| 11106-28* | 28    | 17,5 | 10,8 |
| 11106-32* | 32    | 19,5 | 15,7 |
| 11106-36* | 36    | 21,5 | 22,0 |

\*With loop handle. – Con contromaniglia.



**Sauté pan**

Casseruola bassa  
Stielkasserolle, niedrig  
Plat à sauter  
Cazo recto bajo

| art.      | Ø cm. | h.   | lt.  |
|-----------|-------|------|------|
| 11108-16  | 16    | 6,5  | 1,3  |
| 11108-20  | 20    | 8,0  | 2,5  |
| 11108-24  | 24    | 9,5  | 4,3  |
| 11108-28* | 28    | 11,0 | 6,7  |
| 11108-32* | 32    | 12,5 | 10,0 |
| 11108-36* | 36    | 14,0 | 14,2 |

\*With loop handle. – Con contromaniglia.



**Sauté pan**

Casseruola conica  
Sauteuse  
Sauteuse  
Cazo cónico

| art.     | Ø cm. | h.  | lt. |
|----------|-------|-----|-----|
| 11112-16 | 16    | 6,0 | 1,0 |
| 11112-18 | 18    | 6,0 | 1,2 |
| 11112-20 | 20    | 6,5 | 1,6 |
| 11112-24 | 24    | 7,5 | 2,7 |



**Curved sauté pan**

Casseruola "bombé"  
Sauteuse mit Schüttrand  
Sauteuse bombé  
Cazo bombeado

| art.     | Ø cm. | h.  | lt. |
|----------|-------|-----|-----|
| 11113-18 | 18    | 7,0 | 1,7 |
| 11113-20 | 20    | 7,5 | 2,2 |
| 11113-24 | 24    | 8,5 | 3,3 |
| 11113-26 | 26    | 9,0 | 4,2 |



**Frypan**

Padella  
Bratpfanne  
Poêle à frire  
Sartén

| art.      | Ø cm. | h.  |
|-----------|-------|-----|
| 11114-20  | 20    | 5,0 |
| 11114-24  | 24    | 5,0 |
| 11114-28  | 28    | 5,5 |
| 11114-32  | 32    | 6,0 |
| 11114-36* | 36    | 6,0 |
| 11114-40* | 40    | 6,0 |
| 11114-45* | 45    | 6,5 |

\*With loop handle. – Con contromaniglia.



**Frypan, non stick coating**

Padella, antiaderente  
Bratpfanne mit Antihafbeschichtung  
Poêle avec revêtement anti-adhésif  
Sartén antiaderente

| art.     | Ø cm. | h.  |
|----------|-------|-----|
| 11117-20 | 20    | 5,0 |
| 11117-24 | 24    | 5,0 |
| 11117-28 | 28    | 5,5 |
| 11117-32 | 32    | 6,0 |
| 11117-36 | 36    | 6,0 |
| 11117-40 | 40    | 6,0 |



**French omelet pan**

Tegame  
Servierpfanne  
Poêle à paella  
Paellera

| art.     | Ø cm. | h.  |
|----------|-------|-----|
| 11115-20 | 20    | 5,0 |
| 11115-24 | 24    | 5,0 |
| 11115-28 | 28    | 5,5 |
| 11115-32 | 32    | 6,0 |
| 11115-36 | 36    | 6,0 |
| 11115-40 | 40    | 6,0 |
| 11115-45 | 45    | 6,5 |
| 11115-50 | 50    | 8,0 |



**Cover, reinforced edge**

Coperchio, bordo rinforzato  
Deckel mit Randverstärkung  
Couvercle, bord renforcé  
Tapa, borde reforzado

| art.     | Ø cm. |
|----------|-------|
| 11161-12 | 12    |
| 11161-14 | 14    |
| 11161-16 | 16    |
| 11161-18 | 18    |
| 11161-20 | 20    |
| 11161-22 | 22    |
| 11161-24 | 24    |
| 11161-28 | 28    |
| 11161-32 | 32    |
| 11161-36 | 36    |
| 11161-40 | 40    |
| 11161-45 | 45    |
| 11161-50 | 50    |
| 11161-60 | 60    |





# SERIES 2100

STAINLESS STEEL COOKWARE  
PENTOLAME INOX



The serie 2100 has the same characteristics of the serie 1100. It varies only for the shape of the handles of 2 handles items. Perfect for use on any type of stove, whether gas, electric, glass ceramic cooking surface or induction stove. All items have an induction suited sandwich bottom.

La serie 2100 ha le stesse caratteristiche della serie 1100. Differisce solo per una diversa manicatura sugli articoli a 2 maniglie. Ideali per ogni tipo di cottura, gas, elettrica, vetroceramica e induzione. Tutti gli articoli sono dotati di speciale fondo termodiffusore adatto anche per piastre ad induzione.



**Stock pot**  
Pentola  
Hoher Suppentopf  
Marmite traiteur  
Olla recta

| art.     | Ø cm. | h. | lt.   |
|----------|-------|----|-------|
| 12101-16 | 16    | 16 | 3,2   |
| 12101-20 | 20    | 20 | 6,2   |
| 12101-24 | 24    | 24 | 10,0  |
| 12101-28 | 28    | 28 | 16,5  |
| 12101-32 | 32    | 32 | 24,0  |
| 12101-36 | 36    | 36 | 36,0  |
| 12101-40 | 40    | 40 | 50,0  |
| 12101-45 | 45    | 45 | 70,0  |
| 12101-50 | 50    | 50 | 100,0 |



**Saucepot**  
Casseruola alta  
Fleischtopf  
Brasière  
Cacerola alta

| art.     | Ø cm. | h.   | lt.  |
|----------|-------|------|------|
| 12107-16 | 16    | 11,0 | 2,1  |
| 12107-20 | 20    | 13,0 | 4,0  |
| 12107-24 | 24    | 15,0 | 6,5  |
| 12107-28 | 28    | 17,5 | 10,8 |
| 12107-32 | 32    | 19,5 | 15,7 |
| 12107-36 | 36    | 21,5 | 22,0 |
| 12107-40 | 40    | 24,5 | 30,8 |
| 12107-45 | 45    | 27,5 | 44,0 |
| 12107-50 | 50    | 32,0 | 63,0 |



**Casserole pot**  
Casseruola bassa  
Bratentopf  
Sautoir  
Cacerola baja

| art.     | Ø cm. | h.   | lt.  |
|----------|-------|------|------|
| 12109-16 | 16    | 7,5  | 1,3  |
| 12109-20 | 20    | 8,0  | 2,5  |
| 12109-24 | 24    | 9,5  | 4,3  |
| 12109-28 | 28    | 11,0 | 6,7  |
| 12109-32 | 32    | 12,5 | 10,0 |
| 12109-36 | 36    | 14,0 | 14,2 |
| 12109-40 | 40    | 15,5 | 19,5 |
| 12109-45 | 45    | 17,0 | 27,0 |
| 12109-50 | 50    | 19,0 | 37,0 |



# SERIES 1000

STAINLESS STEEL COOKWARE  
PENTOLAME INOX



Outside and inside satin polished. Non-drip edge. Hollow tubular stay cool handles in stainless steel, ergonomically shaped. Uniform thickness in sides and bottoms. Sandwich thermoradiant bottom (stainless steel-aluminum-stainless steel). Concave bottom when cold and flat when hot (100% heat exploiting). Perfect for use on any type of stove, whether gas, electric, glass ceramic cooking surface or induction stove. All items have an induction suited sandwich bottom.

Finitura esterna ed interna satinata. Bordo a versare. Manicatura tubolare in acciaio inox, anatomica, resistente al calore. Parete e fondo a spessore uniforme. Fondo termodiffusore sandwich (inox-alluminio-inox). Concavo a freddo e piano a caldo (sfruttamento del calore al 100%). Ideali per ogni tipo di cottura, gas, elettrica, vetroceramica e induzione. Tutti gli articoli sono dotati di speciale fondo termodiffusore adatto anche per piastre ad induzione.



**Stock pot**

Pentola  
Hoher Suppentopf  
Marmite traiteur  
Olla recta

| art.     | Ø cm. | h.   | lt.   |
|----------|-------|------|-------|
| 11001-16 | 16    | 16,0 | 3,2   |
| 11001-18 | 18    | 16,0 | 4,0   |
| 11001-20 | 20    | 18,0 | 5,5   |
| 11001-22 | 22    | 22,0 | 8,3   |
| 11001-24 | 24    | 24,0 | 10,5  |
| 11001-28 | 28    | 28,0 | 17,0  |
| 11001-32 | 32    | 27,5 | 20,4  |
| 11001-36 | 36    | 36,0 | 36,5  |
| 11001-40 | 40    | 40,0 | 50,0  |
| 11001-45 | 45    | 40,0 | 63,5  |
| 11001-50 | 50    | 50,0 | 98,0  |
| 11001-60 | 60    | 55,0 | 150,0 |



**Saucepot**

Casseruola alta  
Fleischtopf  
Brasière  
Cacerola alta

| art.     | Ø cm. | h.   | lt.  |
|----------|-------|------|------|
| 11007-16 | 16    | 9,5  | 1,9  |
| 11007-18 | 18    | 10,8 | 2,7  |
| 11007-20 | 20    | 12,0 | 3,8  |
| 11007-22 | 22    | 13,0 | 5,0  |
| 11007-24 | 24    | 14,5 | 6,5  |
| 11007-28 | 28    | 16,0 | 9,8  |
| 11007-32 | 32    | 19,5 | 15,4 |
| 11007-36 | 36    | 21,5 | 20,5 |
| 11007-40 | 40    | 24,0 | 30,1 |
| 11007-45 | 45    | 27,0 | 42,9 |
| 11007-50 | 50    | 30,0 | 58,0 |
| 11007-60 | 60    | 35,0 | 99,0 |



**Casserole pot**

Casseruola bassa  
Bratentopf  
Sautoir  
Cacerola baja

| art.     | Ø cm. | h.   | lt.  |
|----------|-------|------|------|
| 11009-16 | 16    | 6,5  | 1,3  |
| 11009-18 | 18    | 7,0  | 1,8  |
| 11009-20 | 20    | 7,5  | 2,5  |
| 11009-24 | 24    | 8,0  | 3,7  |
| 11009-28 | 28    | 9,5  | 5,8  |
| 11009-32 | 32    | 11,0 | 9,2  |
| 11009-36 | 36    | 13,0 | 13,0 |
| 11009-40 | 40    | 14,5 | 18,0 |
| 11009-45 | 45    | 15,5 | 24,6 |
| 11009-50 | 50    | 19,0 | 37,0 |
| 11009-60 | 60    | 25,0 | 70,7 |



**Saucepan**

Casseruola mezza alta  
Bratentopf, mittelhoch  
Casserole  
Cacerola francés

| art.     | Ø cm. | h. | lt. |
|----------|-------|----|-----|
| 11010-16 | 16    | 8  | 1,6 |
| 11010-18 | 18    | 9  | 2,3 |
| 11010-20 | 20    | 10 | 3,1 |
| 11010-24 | 24    | 12 | 5,4 |



**Sauté pan**

Casseruola conica  
Sauteuse  
Sauteuse  
Cazo cónico

| art.     | Ø cm. | h.  | lt. |
|----------|-------|-----|-----|
| 11012-16 | 16    | 6,0 | 1,0 |
| 11012-18 | 18    | 6,0 | 1,2 |
| 11012-20 | 20    | 6,5 | 1,6 |
| 11012-24 | 24    | 7,5 | 2,7 |



**Curved sauté pan**

Casseruola bombé  
Sauteuse mit Schüttrand  
Sauteuse bombé  
Cazo bombeado

| art.     | Ø cm. | h.  | lt. |
|----------|-------|-----|-----|
| 11013-18 | 18    | 7,0 | 1,7 |
| 11013-20 | 20    | 7,5 | 2,2 |
| 11013-24 | 24    | 8,5 | 3,3 |
| 11013-26 | 26    | 9,0 | 4,2 |





**Saucepan**

Casseruola alta  
Stielkasserolle, hoch  
Casserole haute  
Cazo recto alto

| art.      | Ø cm. | h.   | lt.  |
|-----------|-------|------|------|
| 11006-12  | 12    | 7,0  | 0,8  |
| 11006-14  | 14    | 8,0  | 1,2  |
| 11006-16  | 16    | 9,5  | 1,9  |
| 11006-18  | 18    | 10,8 | 2,7  |
| 11006-20  | 20    | 12,0 | 3,8  |
| 11006-22  | 22    | 13,0 | 5,0  |
| 11006-24  | 24    | 14,5 | 6,5  |
| 11006-28* | 28    | 16,0 | 9,8  |
| 11006-32* | 32    | 19,5 | 15,4 |
| 11006-36* | 36    | 21,5 | 20,5 |

\*With loop handle. – Con contromaniglia.



**Saucepan**

Casseruola mezza alta  
Stielkasserolle, mittelhoch  
Casserole  
Cazo recto francés

| art.     | Ø cm. | h. | lt. |
|----------|-------|----|-----|
| 11011-16 | 16    | 8  | 1,6 |
| 11011-18 | 18    | 9  | 2,3 |
| 11011-20 | 20    | 10 | 3,1 |
| 11011-24 | 24    | 12 | 5,4 |



**Sauté pan**

Casseruola bassa  
Stielkasserolle, niedrig  
Plat à sauter  
Cazo recto bajo

| art.      | Ø cm. | h.   | lt.  |
|-----------|-------|------|------|
| 11008-16  | 16    | 6,5  | 1,3  |
| 11008-18  | 18    | 7,0  | 1,8  |
| 11008-20  | 20    | 7,5  | 2,5  |
| 11008-24  | 24    | 8,0  | 3,7  |
| 11008-28* | 28    | 9,5  | 5,8  |
| 11008-32* | 32    | 11,0 | 9,2  |
| 11008-36* | 36    | 13,0 | 13,0 |

\*With loop handle. – Con contromaniglia.



**Frypan**

Padella  
Bratpfanne  
Poêle à frire  
Sartén

| art.      | Ø cm. | h.  |
|-----------|-------|-----|
| 11014-20  | 20    | 5,0 |
| 11014-24  | 24    | 5,0 |
| 11014-28  | 28    | 5,5 |
| 11014-32  | 32    | 6,0 |
| 11014-36* | 36    | 6,0 |
| 11014-40* | 40    | 6,0 |
| 11114-45* | 45    | 6,5 |

\*With loop handle. – Con contromaniglia.



**Frypan, non stick**

Padella, antiaderente  
Bratpfanne, nichttaftend  
Poêle, anti-adhérente  
Sartén antiadherente

| art.     | Ø cm. | h.  |
|----------|-------|-----|
| 11117-20 | 20    | 5,0 |
| 11117-24 | 24    | 5,0 |
| 11117-28 | 28    | 5,5 |
| 11117-32 | 32    | 6,0 |
| 11117-36 | 36    | 6,0 |
| 11117-40 | 40    | 6,0 |



**French omelet pan**

Tegame  
Servierpfanne  
Poêle à paella  
Paellera

| art.     | Ø cm. | h.  |
|----------|-------|-----|
| 11115-20 | 20    | 5,0 |
| 11115-24 | 24    | 5,0 |
| 11115-28 | 28    | 5,5 |
| 11115-32 | 32    | 6,0 |
| 11115-36 | 36    | 6,0 |
| 11115-40 | 40    | 6,0 |
| 11115-45 | 45    | 6,5 |
| 11115-50 | 50    | 8,0 |



**Cover**

Coperchio  
Deckel  
Couvercle  
Tapa

| art.     | Ø cm. |
|----------|-------|
| 11061-12 | 12    |
| 11061-16 | 16    |
| 11061-18 | 18    |
| 11061-20 | 20    |
| 11061-22 | 22    |
| 11061-24 | 24    |
| 11061-28 | 28    |
| 11061-32 | 32    |
| 11061-36 | 36    |
| 11061-40 | 40    |
| 11061-45 | 45    |
| 11061-50 | 50    |
| 11161-60 | 60    |







# SERIES 2000

STAINLESS STEEL COOKWARE  
PENTOLAME INOX



The serie 2000 has the same characteristics of the serie 1000. It varies only for the shape of the handles of 2 handles items. Perfect for use on any type of stove, whether gas, electric, glass ceramic cooking surface or induction stove. All items have an induction suited sandwich bottom.

La serie 2000 ha le stesse caratteristiche della serie 1000. Differisce solo per una diversa manicatura sugli articoli a 2 maniglie. Ideali per ogni tipo di cottura, gas, elettrica, vetroceramica e induzione. Tutti gli articoli sono dotati di speciale fondo termodiffusore adatto anche per piastre ad induzione.



**Stock pot**

Pentola  
Hoher Suppentopf  
Marmite traiteur  
Olla recta

| art.     | Ø cm. | h.   | lt.   |
|----------|-------|------|-------|
| 12001-16 | 16    | 16,0 | 3,2   |
| 12001-18 | 18    | 16,0 | 4,0   |
| 12001-20 | 20    | 18,0 | 5,5   |
| 12001-22 | 22    | 22,0 | 8,3   |
| 12001-24 | 24    | 24,0 | 10,5  |
| 12001-28 | 28    | 28,0 | 17,0  |
| 12001-32 | 32    | 27,5 | 20,4  |
| 12001-36 | 36    | 36,0 | 36,5  |
| 12001-40 | 40    | 40,0 | 50,0  |
| 12001-45 | 45    | 40,0 | 63,5  |
| 12001-50 | 50    | 50,0 | 98,0  |
| 12001-60 | 60    | 55,0 | 150,0 |



**Saucepot**

Casseruola alta  
Fleischtopf  
Brasière  
Cacerola alta

| art.     | Ø cm. | h.   | lt.  |
|----------|-------|------|------|
| 12007-16 | 16    | 9,5  | 1,9  |
| 12007-18 | 18    | 10,8 | 2,7  |
| 12007-20 | 20    | 12,0 | 3,8  |
| 12007-22 | 22    | 13,0 | 5,0  |
| 12007-24 | 24    | 14,5 | 6,5  |
| 12007-28 | 28    | 16,0 | 9,8  |
| 12007-32 | 32    | 19,5 | 15,4 |
| 12007-36 | 36    | 21,5 | 20,5 |
| 12007-40 | 40    | 24,0 | 30,1 |
| 12007-45 | 45    | 27,0 | 42,9 |
| 12007-50 | 50    | 30,0 | 58,0 |
| 12007-60 | 60    | 35,0 | 99,0 |



**Casserole pot**

Casseruola bassa  
Bratentopf  
Sautoir  
Cacerola baja

| art.     | Ø cm. | h.   | lt.  |
|----------|-------|------|------|
| 12009-16 | 16    | 6,5  | 1,3  |
| 12009-18 | 18    | 7,0  | 1,8  |
| 12009-20 | 20    | 7,5  | 2,5  |
| 12009-24 | 24    | 8,0  | 3,7  |
| 12009-28 | 28    | 9,5  | 5,8  |
| 12009-32 | 32    | 11,0 | 9,2  |
| 12009-36 | 36    | 13,0 | 13,0 |
| 12009-40 | 40    | 14,5 | 18,0 |
| 12009-45 | 45    | 15,5 | 24,6 |
| 12009-50 | 50    | 19,0 | 37,0 |
| 12009-60 | 60    | 25,0 | 70,7 |



**Sauté pan**

Casseruola conica  
Sauteuse  
Sauteuse  
Cazo cónico

| art.     | Ø cm. | h.  | lt. |
|----------|-------|-----|-----|
| 11012-16 | 16    | 6,0 | 1,0 |
| 11012-18 | 18    | 6,0 | 1,2 |
| 11012-20 | 20    | 6,5 | 1,6 |
| 11012-24 | 24    | 7,5 | 2,7 |



**Curved sauté pan**

Casseruola bombé  
Sauteuse mit Schüttrand  
Sauteuse bombé  
Cazo bombeado

| art.     | Ø cm. | h.  | lt. |
|----------|-------|-----|-----|
| 11013-18 | 18    | 7,0 | 1,7 |
| 11013-20 | 20    | 7,5 | 2,2 |
| 11013-24 | 24    | 8,5 | 3,3 |
| 11013-26 | 26    | 9,0 | 4,2 |



**Saucepan**

Casseruola mezza alta  
Stielkasserolle, mittelhoch  
Casserole  
Cazo recto francés

| art.     | Ø cm. | h.   | lt. |
|----------|-------|------|-----|
| 11011-16 | 16    | 8,0  | 1,6 |
| 11011-18 | 18    | 9,0  | 2,3 |
| 11011-20 | 20    | 10,0 | 3,1 |
| 11011-24 | 24    | 12,0 | 5,4 |



**Steamer pot, perforated bottom**

Inserto a vapore, fondo forato  
Dampf-Siebeinsatz  
Casserole à vapeur, perforée  
Cacerola base perforada

| art.     | Ø cm. | h.   |
|----------|-------|------|
| 12119-20 | 20    | 12,5 |
| 12119-24 | 24    | 15,0 |
| 12119-28 | 28    | 17,0 |
| 12119-32 | 32    | 19,0 |



**Asparagus-pot with lid**

Pentola cuociasparagi con coperchio  
Spargeltopf mit Deckel  
Cuit-asperges avec couvercle  
Olla espárragos con tapa

| art.     | Ø cm. | h.   | lt. |
|----------|-------|------|-----|
| 12037-16 | 16    | 24,0 | 4,8 |



**Saucepan**

Casseruola alta  
Stielkasserolle, hoch  
Casserole haute  
Cazo recto alto

| art.      | Ø cm. | h.   | lt.  |
|-----------|-------|------|------|
| 11006-12  | 12    | 7,0  | 0,8  |
| 11006-14  | 14    | 8,0  | 1,2  |
| 11006-16  | 16    | 9,5  | 1,9  |
| 11006-18  | 18    | 10,8 | 2,7  |
| 11006-20  | 20    | 12,0 | 3,8  |
| 11006-22  | 22    | 13,0 | 5,0  |
| 11006-24  | 24    | 14,5 | 6,5  |
| 11006-28* | 28    | 16,0 | 9,8  |
| 11006-32* | 32    | 19,5 | 15,4 |
| 11006-36* | 36    | 21,5 | 20,5 |

\*With loop handle. – Con contromaniglia.



**Sauté pan**

Casseruola bassa  
Stielkasserolle, niedrig  
Plat à sauter  
Cazo recto bajo

| art.      | Ø cm. | h.   | lt.  |
|-----------|-------|------|------|
| 11008-16  | 16    | 6,5  | 1,3  |
| 11008-18  | 18    | 7,0  | 1,8  |
| 11008-20  | 20    | 7,5  | 2,5  |
| 11008-24  | 24    | 8,0  | 3,7  |
| 11008-28* | 28    | 9,5  | 5,8  |
| 11008-32* | 32    | 11,0 | 9,2  |
| 11008-36* | 36    | 13,0 | 13,0 |

\*With loop handle. – Con contromaniglia.



**Frypan**

Padella  
Bratpfanne  
Poêle à frire  
Sartén

| art.      | Ø cm. | h.  |
|-----------|-------|-----|
| 11014-20  | 20    | 5,0 |
| 11014-24  | 24    | 5,0 |
| 11014-28  | 28    | 5,5 |
| 11014-32  | 32    | 6,0 |
| 11014-36* | 36    | 6,0 |
| 11014-40* | 40    | 6,0 |
| 11114-45* | 45    | 6,5 |

\*With loop handle. – Con contromaniglia.



**Frypan, non stick**

Padella, antiaderente  
Bratpfanne, nichthaftend  
Poêle, anti-adhérente  
Sartén antiadherente

| art.     | Ø cm. | h.  |
|----------|-------|-----|
| 11117-20 | 20    | 5,0 |
| 11117-24 | 24    | 5,0 |
| 11117-28 | 28    | 5,5 |
| 11117-32 | 32    | 6,0 |
| 11117-36 | 36    | 6,0 |
| 11117-40 | 40    | 6,0 |



**French omelet pan**

Tegame  
Servierpfanne  
Poêle à paella  
Paellera

| art.     | Ø cm. | h.  |
|----------|-------|-----|
| 11115-20 | 20    | 5,0 |
| 11115-24 | 24    | 5,0 |
| 11115-28 | 28    | 5,5 |
| 11115-32 | 32    | 6,0 |
| 11115-36 | 36    | 6,0 |
| 11115-40 | 40    | 6,0 |
| 11115-45 | 45    | 6,5 |
| 11115-50 | 50    | 8,0 |



**Cover**

Coperchio  
Deckel  
Couvercle  
Tapa

| art.     | Ø cm. |
|----------|-------|
| 11061-16 | 16    |
| 11061-18 | 18    |
| 11061-20 | 20    |
| 11061-22 | 22    |
| 11061-24 | 24    |
| 11061-28 | 28    |
| 11061-32 | 32    |
| 11061-36 | 36    |
| 11061-40 | 40    |
| 11061-45 | 45    |
| 11061-50 | 50    |
| 11161-60 | 60    |





# FOR GLUTEN-FREE COOKING



AL SERVIZIO DELLA CUCINA SENZA GLUTINE

FOR PRODUCT # LIST SEE PAGES FROM 518 TO 523  
PER L'ELENCO PRODOTTI VEDI PAGINE DA 518 A 523



Consistently with the functional approach, which has always marked the brand, Paderno offers a complete product line and professional tools, easily recognizable in the kitchen, which can reduce possible mistakes during their use to protect people affected by celiac disease. Developed and realized in 2013 in collaboration with Associazione Italiana Celiachia Lombardia ONLUS (Italian Society for the Celiac Disease – Lombardy Section), this project makes Sambonet Paderno Industrie S.p.A. the first company in its market that offers to the HoReCa channel a complete line of items intended for gluten-free cooking.

Some distinguished special features, such as golden PVD handles for pans and pots and a special customised logo for utensils, will allow professionals to easily identify all these items in the kitchen.

This product line aims at:

- Reducing the risk of accidental food cross-contamination;
- Making it easier for professionals to work and provide services to clients with food intolerances;
- Raising awareness on the gluten-free diet issue in the industry so as to respond to the new needs of consumers.

Coerentemente all'ottica di servizio che contraddistingue da sempre il marchio, Paderno propone una linea completa di articoli e strumenti professionali facilmente identificabili in cucina, in grado di abbattere eventuali errori durante il loro utilizzo a salvaguardia del cliente celiaco e di tutti gli intolleranti. Sviluppato e concretizzato nel 2013 in collaborazione con l'Associazione Italiana Celiachia Lombardia ONLUS, questo progetto colloca Sambonet Paderno Industrie come prima azienda del settore a offrire al canale Ho.Re.Ca una linea completa di articoli da destinare alla preparazione di pietanze senza glutine.

Attraverso alcuni elementi distintivi e differenzianti, come manici in PVD oro per pentole e padelle e personalizzazione con un logo specifico per utensili, tutti gli strumenti saranno facilmente identificabili in cucina.

Questa gamma contribuisce a:

- Diminuire il rischio di accidentali contaminazioni crociate degli alimenti;
- Facilitare il professionista nell'operare e nell'offrire un servizio a favore del cliente con intolleranze alimentari;
- Sensibilizzare il settore sul tema "gluten free" di fronte alle nuove esigenze dei consumatori.



**Stock pot**  
Pentola alta  
Hoher Suppentopf  
Marmite traiteur  
Olla recta

| art.     | Ø cm. | h. cm. | lt.  |
|----------|-------|--------|------|
| 12001F20 | 20    | 18,0   | 5,5  |
| 12001F24 | 24    | 24,0   | 10,5 |
| 12001F28 | 28    | 28,0   | 17,0 |



**Colander for stock pot**  
Colapasta per pentola  
Seiher für Suppentopf  
Passoire pour marmite  
Colador para olla recta

| art.     | Ø cm. | h. cm. |
|----------|-------|--------|
| 12123F20 | 20    | 22,0   |
| 12123F24 | 24    | 26,5   |
| 12123F28 | 28    | 29,5   |



**Saucepot 2 handles**  
Casseruola alta 2 maniglie  
Fleischtopf  
Brsière  
Cacerola alta

| art.     | Ø cm. | h. cm. | lt. |
|----------|-------|--------|-----|
| 12007F16 | 16    | 9,5    | 1,9 |
| 12007F24 | 24    | 14,5   | 6,5 |
| 12007F28 | 28    | 16,0   | 9,8 |



**Frypan**  
Padella  
Bratpfanne  
Poêle à frire  
Sartén

| art.     | Ø cm. | h. cm. |
|----------|-------|--------|
| 11014F20 | 20    | 5,0    |
| 11014F24 | 24    | 5,0    |
| 11014F28 | 28    | 5,5    |
| 11014F32 | 32    | 6,0    |



**Cover**  
Coperchio  
Deckel  
Couvercle  
Tapa

| art.     | Ø cm. |
|----------|-------|
| 11161F16 | 16    |
| 11161F20 | 20    |
| 11161F24 | 24    |
| 11161F28 | 28    |



**Strainer with hook**  
Colapasta con manico e gancio  
Stielsieb mit Haken  
Passoire avec poignée et crochet  
Colador con asa y gancho

| art.     | Ø cm. | h. cm. | lt. |
|----------|-------|--------|-----|
| 11924F20 | 20    | 12     | 3,6 |



**Conical colander**  
Colapasta tronco conico  
Konisches Gemüsesieher  
Passoire à légumes conique  
Colador cónico

| art.     | Ø cm. | h. cm. | lt. |
|----------|-------|--------|-----|
| 11930F24 | 24    | 12     | 3,5 |



**Labels 14 allergens**  
Etichette 14 allergeni  
Etiketten 14 Allergene  
Etiquettes 14 allergènes  
Etiquetas 14 alergenos

| art.     | dim. cm. | Pcs/Pz |
|----------|----------|--------|
| 44630-02 | 7,5x4    | 500    |

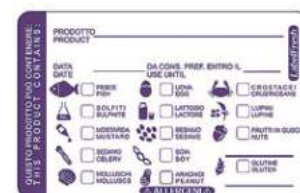

**Labels Allergens**  
Etichette allergeni  
Etiketten Allergene  
Etiquettes allergènes  
Etiquetas alérgenos

| art.     | dim. cm. | Pcs/Pz |
|----------|----------|--------|
| 44630-06 | 7x4,5    | 500    |



**Delivery labels with allergens**  
Etichette delivery con allergeni  
Lieferetiketten mit Allergenen  
Etiquettes livraison avec allergènes  
Etiquetas entrega con alérgenos

| art.     | dim. cm. | Pcs/Pz |
|----------|----------|--------|
| 44630-07 | 14x4,5   | 250    |



**Cutting board**  
Tagliere  
Tranchierbrett  
Planche à découper  
Tabla de corte

| art.     | GN  | dim. cm.  | col. |
|----------|-----|-----------|------|
| 42538-00 | 1/1 | 53x32,5x2 | ○    |
| 42538-01 | 1/1 | 53x32,5x2 | ●    |
| 42538-02 | 1/1 | 53x32,5x2 | ●    |
| 42538-03 | 1/1 | 53x32,5x2 | ●    |
| 42538-04 | 1/1 | 53x32,5x2 | ●    |
| 42538-05 | 1/1 | 53x32,5x2 | ●    |
| 42538-09 | 1/1 | 53x32,5x2 | ●    |



**Cutting board**  
Tagliere  
Tranchierbrett  
Planche à découper  
Tabla de corte

| art.     | GN  | dim. cm.  | col. |
|----------|-----|-----------|------|
| 42522-07 | -   | 32x26,5x2 | ●    |
| 42538-07 | 1/1 | 53x32,5x2 | ●    |
| 42539-07 | -   | 60x40x2   | ●    |

**See also pages 164-165.**  
Vedi anche pagg 164-165.



**GN-containers**  
GN bacinelle  
GN-Behälter  
GN bacs  
GN cubetas

| art.     | des | dim. cm.     | lt.  |
|----------|-----|--------------|------|
| 15101-10 | 1/1 | 53x32,5x10   | 13,3 |
| 15105-10 | 1/2 | 32,5x26,5x10 | 6,1  |
| 15107-10 | 1/3 | 32,5x17,5x10 | 3,8  |
| 15108-10 | 1/4 | 26,4x16,2x10 | 2,6  |
| 15109-10 | 1/6 | 17,6x16,2x10 | 1,6  |
| 15110-10 | 1/9 | 17,6x10,8x10 | 0,9  |

**See also pages 68-71. – Vedi anche pagg 68-71.**



**GN-lids**  
GN coperchi  
GN-Deckel  
GN couvercles  
GN tapas

| art.     | des | dim. cm.  |
|----------|-----|-----------|
| 14922-77 | 1/1 | 53x3,25   |
| 14925-77 | 1/2 | 32,5x26,5 |
| 14927-77 | 1/3 | 32,5x17,5 |
| 14928-77 | 1/4 | 26,4x16,2 |
| 14929-77 | 1/6 | 17,6x16,2 |
| 14930-77 | 1/9 | 17,6x10,8 |



**Digital thermometer**  
Termometro digitale  
Elektronisches Thermometer  
Thermomètre digital  
Termómetro digital

| art.     | range         | res.    |
|----------|---------------|---------|
| 49880-17 | -49,9>299,9°C | 0,1/1°C |

**IP66/67. Dim. 19x50x157 mm.**  
**See also page 130. – Vedi anche pag 130.**

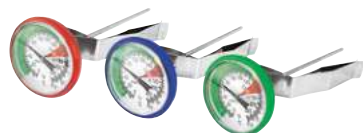

**Milk frothing thermometers, 3 pcs**  
Termometri latte/barista, 3 pz  
Mich-Thermometer, 3 Stk  
Thermomètres à lait, 3 pièces  
Termómetros leche, 3 pz

| art.     | Ø cm. | range     | res. |
|----------|-------|-----------|------|
| 49709-03 | 4,5   | -10+110°C | 1°C  |

**Red, green and blue, to easily identify different types of milk used, to avoid cross-contamination. Stem 175 mm. – Rosso, verde e blu, per identificare facilmente i diversi tipi di latte utilizzati, per evitare la contaminazione incrociata. Stelo 175 mm.**

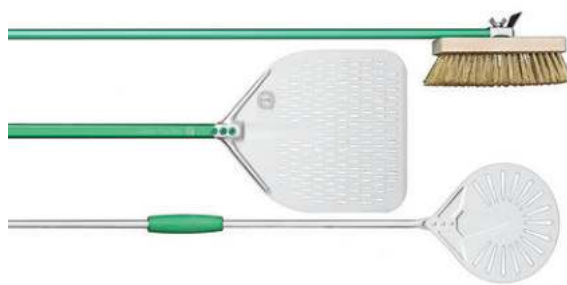

**Adjustable brush, pizza peels**  
Spazzola orientabile, pale pizza  
Drehbare Bürste, Pizzaschaufeln  
Brosse orientable, pelles à pizza  
Cepillo orientable, palas pizza

| art.     | des                  | Ø cm. | dim. cm. | l. cm. |
|----------|----------------------|-------|----------|--------|
| 41767G20 | Brush/Spazzola       | -     | 20x6     | 160    |
| 41704G33 | Peel/Pala            | -     | 33x33    | 150    |
| 41704G36 | Peel/Pala            | -     | 36x36    | 150    |
| 41737G20 | Small peel/Palettino | 20    | -        | 150    |
| 41737G23 | Small peel/Palettino | 23    | -        | 150    |

**See also page 266. – Vedi anche pag 266.**





# SERIES 2500 3-PLY

STAINLESS STEEL COOKWARE  
PENTOLAME INOX



INDUCTION  
READY!



Paderno serie 2500 3-ply is especially designed for professional kitchens, features super heat-conductive multi-layer construction that distributes heat from bottom to rim quickly and evenly. Outside and inside satin polished. Non-drip edge. Stainless steel handles, ergonomically shaped. Uniform thickness in sides and bottoms. Energy saving on all types of cookers. Suitable for all cooking ranges, induction hobs included.

La serie Paderno 2500 3-ply concepita per l'utilizzo nelle cucine professionali è costruita in materiale multistrato che assicura una distribuzione rapida ed uniforme del calore su tutta la superficie dell'utensile. Finitura esterna ed interna satinata. Bordo a versare. Manicatura anatomica in acciaio inox. Parete e fondo a spessore uniforme. Risparmio di energia su tutti i piani di cottura. Ideali per ogni tipo di cottura inclusa l'induzione.



**Saucepot**

Casseruola alta  
Fleischtopf  
Brasière  
Cacerola alta

| art.     | Ø cm. | h.   | lt. |
|----------|-------|------|-----|
| 12507-24 | 24    | 11,5 | 5,0 |
| 12507-28 | 28    | 14,0 | 8,5 |



**Casserole pot**

Casseruola bassa  
Bratentopf  
Sautoir  
Cacerola baja

| art.     | Ø cm. | h.   | lt. |
|----------|-------|------|-----|
| 12509-20 | 20    | 9,5  | 2,8 |
| 12509-24 | 24    | 10,5 | 4,7 |
| 12509-28 | 28    | 11,0 | 6,5 |



**Saucepan**

Casseruola mezza alta  
Stielkasserolle, mittelhoch  
Casserole  
Cazo recto francés

| art.     | Ø cm. | h.   | lt. |
|----------|-------|------|-----|
| 12511-16 | 16    | 7,5  | 1,5 |
| 12511-18 | 18    | 8,0  | 2,0 |
| 12511-20 | 20    | 8,8  | 2,5 |
| 12511-24 | 24    | 10,5 | 4,6 |



**Sauté pan**

Casseruola bassa  
Stielkasserolle, niedrig  
Plat à sauter  
Cazo recto bajo

| art.     | Ø cm. | h.  | lt. |
|----------|-------|-----|-----|
| 12508-24 | 24    | 5,0 | 2,0 |



**Wok with grid and cover**

Wok c/griglia e coperchio  
Wok mit Rost und Deckel  
Wok avec grille et couvercle  
Wok con rejilla y tapa

| art.     | Ø cm. | h. |
|----------|-------|----|
| 12529-32 | 32    | 8  |



**Curved sauté pan**

Casseruola bombé  
Sauteuse mit Schüttrand  
Sauteuse bombé  
Cazo bombeado

| art.     | Ø cm. | h.  | lt. |
|----------|-------|-----|-----|
| 12513-16 | 16    | 6,0 | 1,2 |
| 12513-18 | 18    | 6,5 | 1,6 |
| 12513-20 | 20    | 7,0 | 2,0 |
| 12513-24 | 24    | 8,5 | 3,8 |



**Frypan**

Padella  
Bratpfanne  
Poêle à frire  
Sartén

| art.     | Ø cm. | h.  |
|----------|-------|-----|
| 12514-24 | 24    | 5,5 |
| 12514-26 | 26    | 5,5 |
| 12514-28 | 28    | 5,5 |
| 12514-32 | 32    | 4,0 |
| 12514-36 | 36    | 4,0 |



**Frypan, non stick coating**

Padella, antiaderente  
Bratpfanne mit Antihaftbeschichtung  
Poêle avec revêtement anti-adhésif  
Sartén antiadherente

| art.     | Ø cm. | h.  |
|----------|-------|-----|
| 12517-24 | 24    | 5,5 |
| 12517-26 | 26    | 5,5 |
| 12517-28 | 28    | 5,5 |
| 12517-32 | 32    | 5,5 |
| 12517-36 | 36    | 5,5 |



**Frypan**

Padella  
Bratpfanne  
Poêle à frire  
Sartén

| art.     | Ø cm. | h.  |
|----------|-------|-----|
| 12514-20 | 20    | 3,0 |

**Mirror finishing.** – Finitura lucida.



**Saucepot with lid**

Casseruola alta, con coperchio  
Fleischtopf mit Deckel  
Brasière avec couvercle  
Cacerola alta con tapa

| art.     | Ø cm. | h. | lt. |
|----------|-------|----|-----|
| 12509-12 | 12    | 6  | 0,7 |

**Mirror finishing.** – Finitura lucida.



**Sauté pan with double spouts**

Casseruola bassa con doppio becco  
Stielkasserolle, niedrig, 2 Schnabel  
Plat à sauter, 2 becs  
Cazo recto bajo, 2 picos

| art.     | Ø cm. | h. | lt. |
|----------|-------|----|-----|
| 12511-10 | 10    | 5  | 0,4 |

**Mirror finishing.** – Finitura lucida.



**Sauté pan**

Casseruola bassa  
Stielkasserolle, niedrig  
Plat à sauter  
Cazo recto bajo

| art.     | Ø cm. | h. | lt. |
|----------|-------|----|-----|
| 12511-12 | 12    | 6  | 0,7 |
| 12511-14 | 14    | 7  | 1,0 |

**Mirror finishing.** – Finitura lucida.



**Cover**

Coperchio  
Deckel  
Couvercle  
Tapa

| art.     | Ø cm. |
|----------|-------|
| 12561-12 | 12    |
| 12561-16 | 16    |
| 12561-18 | 18    |
| 12561-20 | 20    |
| 12561-24 | 24    |
| 12561-26 | 26    |
| 12561-28 | 28    |



**Cover**

Coperchio  
Deckel  
Couvercle  
Tapa

| art.     | Ø cm. |
|----------|-------|
| 11061-12 | 12    |
| 11061-16 | 16    |
| 11061-18 | 18    |
| 11061-20 | 20    |
| 11061-24 | 24    |
| 11061-28 | 28    |







# MISCELLANEOUS COMPLEMENTI

STAINLESS STEEL COOKWARE  
PENTOLAME INOX

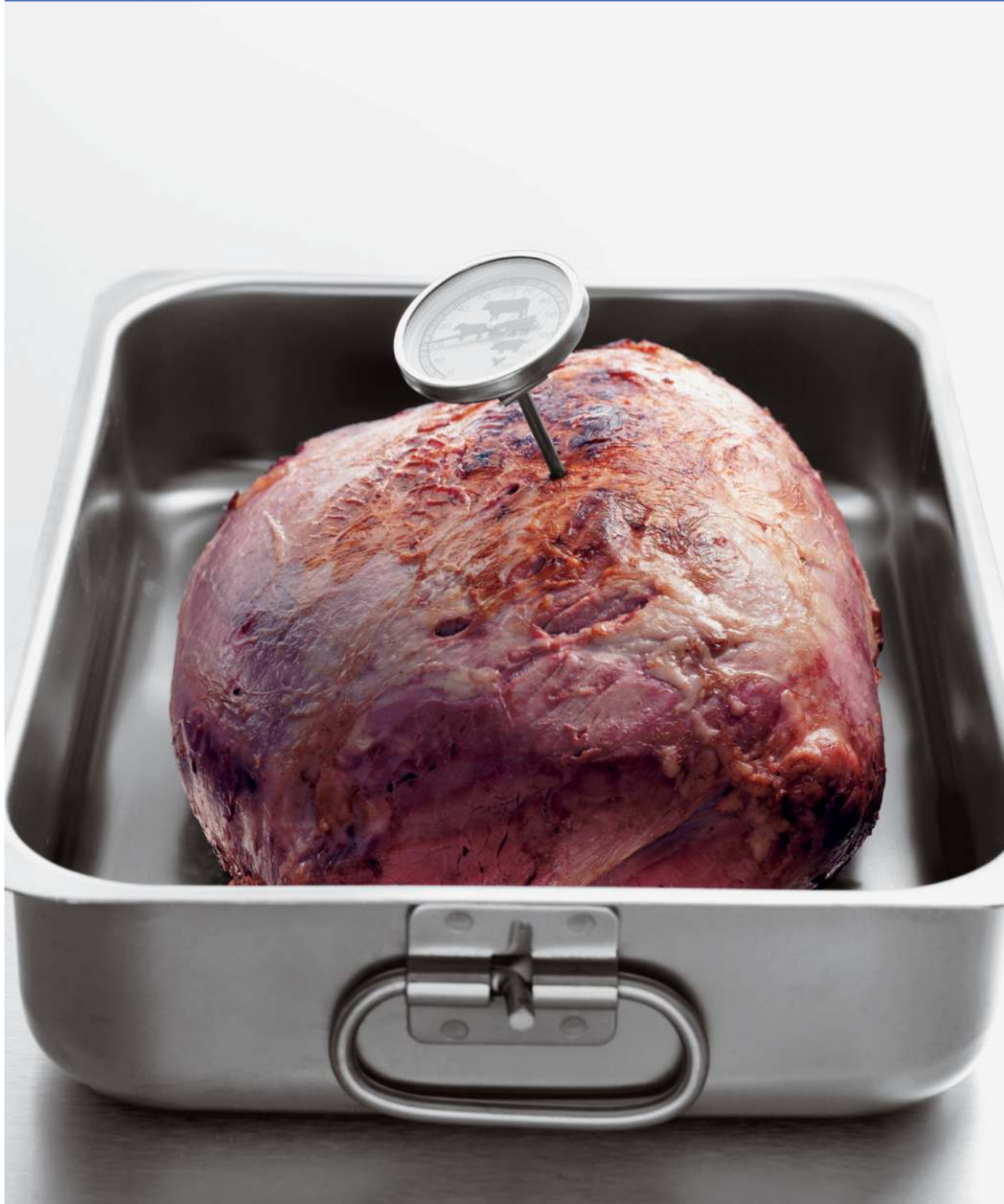



**Roasting pan**

Tegame  
Bräter  
Plaque à rôtir  
Rustidera

| art.     | cm.   | h. |
|----------|-------|----|
| 11941-35 | 35x25 | 8  |
| 11941-40 | 40x26 | 9  |
| 11941-45 | 45x30 | 9  |
| 11941-50 | 50x30 | 9  |
| 11941-60 | 60x35 | 9  |



**Heavy roasting pan**

Tegame pesante  
Bräter, Schwerausführung  
Plaque à rôtir lourde  
Rustidera pesada

| art.      | cm.   | h. |
|-----------|-------|----|
| 11943-40  | 40x26 | 9  |
| 11943-45  | 45x30 | 9  |
| 11943-50  | 50x30 | 9  |
| 11943-60  | 60x35 | 9  |
| 11943-61* | 61x43 | 9  |

\*For 2/1 GN ovens. – Per forno GN 2/1.



**Heavy roasting pan**

Tegame pesante  
Bräter, Schwerausführung  
Plaque à rôtir lourde  
Rustidera pesada

| art.      | cm.   | h. |
|-----------|-------|----|
| 11944-40  | 40x26 | 9  |
| 11944-45  | 45x30 | 9  |
| 11944-50  | 50x30 | 9  |
| 11944-60  | 60x35 | 9  |
| 11944-61* | 61x43 | 9  |

\*For 2/1 GN ovens. – Per forno GN 2/1.



**Lid**

Coperchio  
Deckel  
Couvercle  
Tapa

| art.      | cm.   |
|-----------|-------|
| 11948-40  | 40x26 |
| 11948-45  | 45x30 |
| 11948-50  | 50x30 |
| 11948-60  | 60x35 |
| 11948-61* | 61x43 |

\*For 2/1 GN ovens. – Per forno GN 2/1.



**Roasting pan with cover**

Brasiera con coperchio  
Brasiere mit Deckel  
Braisière avec couvercle  
Rustidera alta con tapa

| art.      | cm.   | h. |
|-----------|-------|----|
| 11965-50  | 50x30 | 15 |
| 11965-60  | 60x35 | 15 |
| 11965-61* | 61x43 | 15 |

\*For 2/1 GN ovens. – Per forno GN 2/1.



**Fry dripping tray, stainless steel**

Colafritto, inox  
Pommes-Frites-Seiher, Edelstahl Rostfrei  
Egouttoir à friture, inox  
Escurridor para fritura, inox

| art.     | Ø cm. | h. |
|----------|-------|----|
| 41930-39 | 41    | 14 |

**Detachable drip tray.**

Vassoio raccogli liquidi removibile.



INDUCTION  
READY!

**Fish kettle**

Pesciera  
Fischkochkessel  
Poissonnière  
Hervidor pescado

| art.     | cm.       | h.   |
|----------|-----------|------|
| 41964-45 | 46x15,5   | 10,5 |
| 41964-60 | 61,5x18,5 | 11,0 |

**Equipped with grid and cover.**

Fornita con griglia e coperchio.



**Whistling kettle**

Bollitore  
Kocher  
Bouilloire à sifflet  
Pava

| art.     | Ø cm. | h. | lt. |
|----------|-------|----|-----|
| 41914-03 | 20    | 18 | 2,8 |



**Canister**

Contentitore cilindrico  
Behälter  
Bahut  
Contenedor cilíndrico

| art.     | Ø cm. | h. | lt.  |
|----------|-------|----|------|
| 11913-16 | 16    | 12 | 2,4  |
| 11913-20 | 20    | 16 | 5,0  |
| 11913-24 | 24    | 20 | 9,0  |
| 11913-28 | 28    | 24 | 14,5 |



**Bain-marie pot**

Casseruola bagnomaria  
Wasserbadkasserolle  
Casserole bain-marie  
Baño maria

| art.     | Ø cm. | h. | lt. |
|----------|-------|----|-----|
| 11910-12 | 12    | 14 | 1,4 |
| 11910-14 | 14    | 16 | 2,5 |
| 11910-16 | 16    | 18 | 3,6 |
| 11910-18 | 18    | 20 | 5,0 |
| 11910-20 | 20    | 22 | 7,0 |



**Bain-marie pot**

Bagnomaria  
Behälter  
Casserole bain-marie  
Baño maria

| art.     | Ø cm. | h. | lt. |
|----------|-------|----|-----|
| 11911-12 | 12    | 14 | 1,4 |
| 11911-14 | 14    | 16 | 2,5 |
| 11911-16 | 16    | 18 | 3,6 |
| 11911-18 | 18    | 20 | 5,0 |
| 11911-20 | 20    | 22 | 7,0 |



**Bain-marie, stackable**

Bagno-maria impilabili  
Bain-Marie, stapelbar  
Bain-marie, empilables  
Baño maria, apilable

| art.     | cm.   | h.   | lt.  |
|----------|-------|------|------|
| 44501-01 | 24x24 | 23,5 | 13,0 |
| 44501-02 | 24x24 | 16,0 | 9,0  |
| 44501-03 | 24x24 | 7,5  | 4,0  |



**Bain-marie, stackable**

Bagno-maria impilabili  
Bain-Marie, stapelbar  
Bain-marie, empilables  
Baño maria, apilable

| art.     | cm.       | h.   | lt. |
|----------|-----------|------|-----|
| 44502-01 | 15,5x15,5 | 23,5 | 5,0 |
| 44502-02 | 15,5x15,5 | 16,0 | 3,5 |
| 44502-03 | 15,5x15,5 | 7,5  | 1,5 |



**Bain-marie, stackable**

Bagno-maria impilabili  
Bain-Marie, stapelbar  
Bain-marie, empilables  
Baño maria, apilable

| art.     | cm.       | h.   | lt. |
|----------|-----------|------|-----|
| 44503-01 | 15,5x10,5 | 16,0 | 2,5 |
| 44503-02 | 15,5x10,5 | 7,5  | 1,0 |
| 44503-03 | 15,5x10,5 | 5,5  | 0,5 |



**Bain-marie lid**

Coperchio bagnomaria  
Wasserbadkasserolle-Deckel  
Couverte pour bain-marie  
Tapa para baño maria

| art.     | cm.       |
|----------|-----------|
| 44501-04 | 24x24     |
| 44502-04 | 15,5x15,5 |
| 44503-04 | 15,5x10,5 |



**1/4-Segment colander**

Colapasta 1/4  
1/4 Seiher-Einsatz  
Passoire cuit-pâtes, 1/4  
Colador 1/4

| art.     | Ø cm. | h. | lt. |
|----------|-------|----|-----|
| 11922-36 | 36    | 23 | 5,5 |
| 11922-40 | 40    | 26 | 7,5 |

**For items/Per art.:**  
**11007-11107-12007-12107-16929.**



**1/4-Segment wire colander**

Colapasta 1/4 a rete  
1/4 Netzseiher-Einsatz  
Passoire cuit-pâtes à gaze, 1/4  
Colador red 1/4

| art.     | Ø cm. | h. |
|----------|-------|----|
| 12992-36 | 36    | 23 |
| 12992-40 | 40    | 26 |

**For items/Per art.:**  
**11007-11107-12007-12107-16929.**





# SERIES 6100

ALUMINUM COOKWARE  
PENTOLAME ALLUMINIO



Made in heavy duty aluminum.  
Hollow tubular handles in stainless steel 18/10, stay cool.  
Rounded corners provide easy cleanup.  
Thickness from mm 2 to mm 5,5.

Esecuzione in alluminio pesante.  
Manicatura tubolare in acciaio inossidabile 18/10, resistente al calore.  
Ampio raggio di raccordo fondo-parete, igienico e facile da pulire.  
Spessore da mm 2 a mm 5,5.



**Stock pot**

Pentola  
Hoher Suppentopf  
Marmite traiteur  
Olla recta

| art.     | Ø cm. | h.   | lt.   |
|----------|-------|------|-------|
| 16101-16 | 16    | 16,0 | 3,2   |
| 16101-20 | 20    | 20,0 | 6,2   |
| 16101-24 | 24    | 24,0 | 10,0  |
| 16101-28 | 28    | 28,0 | 16,5  |
| 16101-32 | 32    | 29,5 | 22,0  |
| 16101-36 | 36    | 36,0 | 36,0  |
| 16101-40 | 40    | 40,0 | 50,0  |
| 16101-45 | 45    | 45,0 | 70,0  |
| 16101-50 | 50    | 50,0 | 100,0 |



**Saucepot**

Casseruola alta  
Fleischtopf  
Brasière  
Cacerola alta

| art.     | Ø cm. | h.   | lt.  |
|----------|-------|------|------|
| 16107-16 | 16    | 11,0 | 2,1  |
| 16107-20 | 20    | 13,0 | 4,0  |
| 16107-24 | 24    | 15,0 | 6,5  |
| 16107-28 | 28    | 17,5 | 10,8 |
| 16107-32 | 32    | 19,5 | 15,7 |
| 16107-36 | 36    | 21,0 | 21,5 |
| 16107-40 | 40    | 24,0 | 30,0 |
| 16107-45 | 45    | 27,0 | 43,0 |
| 16107-50 | 50    | 30,0 | 59,0 |



**Casserole pot**

Casseruola bassa  
Bratentopf  
Sautoir  
Cacerola baja

| art.     | Ø cm. | h.   | lt.  |
|----------|-------|------|------|
| 16109-24 | 24    | 9,5  | 4,3  |
| 16109-28 | 28    | 11,0 | 6,7  |
| 16109-32 | 32    | 12,5 | 10,0 |
| 16109-36 | 36    | 14,0 | 14,0 |
| 16109-40 | 40    | 16,0 | 20,0 |
| 16109-45 | 45    | 18,0 | 28,5 |
| 16109-50 | 50    | 19,0 | 37,0 |
| 16109-60 | 60    | 21,5 | 60,0 |



**Colander for stock pot**

Colapasta per pentola  
Seiher für Suppentopf  
Passoire pour marmite  
Colador para olla recta

| art.     | Ø cm. | h. |
|----------|-------|----|
| 16926-32 | 32    | 31 |
| 16926-36 | 36    | 37 |
| 16926-40 | 40    | 40 |



**Couscous pan**

Couscoussiera  
Couscoustopf  
Couscoussier  
Cuscusera

| art.     | Ø cm. | h.    | lt. |
|----------|-------|-------|-----|
| 46970-18 | 36    | 22+17 | 18  |
| 46970-25 | 40    | 25+20 | 25  |



**Sauce-pot, aluminum**

Casseruola, alluminio  
Gemüsetopf, Aluminium  
Braisière, alu  
Cacerola, aluminio

| art.     | Ø cm. | h. | lt.  |
|----------|-------|----|------|
| 16929-36 | 36    | 17 | 17,0 |
| 16929-40 | 40    | 18 | 22,5 |



**Oval saucepan with cover**

Casseruola ovale con coperchio  
Ovale Kasserolle mit Deckel  
Casserole ovale avec couvercle  
Cacerola oval con tapa

| art.     | Ø cm. | h.   | lt. |
|----------|-------|------|-----|
| 16938-36 | 36    | 14,5 | 10  |
| 16938-40 | 40    | 16,0 | 14  |
| 16938-45 | 45    | 17,0 | 19  |



**Saucepan**

Casseruola alta  
Stielkasserolle, hoch  
Casserole haute  
Cazo recto alto

| art.     | Ø cm. | h.   | lt.  |
|----------|-------|------|------|
| 16106-16 | 16    | 11,0 | 2,1  |
| 16106-20 | 20    | 13,0 | 4,0  |
| 16106-24 | 24    | 15,0 | 6,5  |
| 16106-28 | 28    | 17,5 | 10,8 |



**Casserole pot**

Casseruola bassa  
Stielkasserolle, niedrig  
Sautoir  
Cacerola baja

| art.     | Ø cm. | h.   | lt. |
|----------|-------|------|-----|
| 16108-20 | 20    | 8,0  | 2,5 |
| 16108-24 | 24    | 9,5  | 4,3 |
| 16108-28 | 28    | 11,0 | 6,7 |



**Frypan**  
Padella  
Bratpfanne  
Poêle à frire  
Sartén

| art.     | Ø cm. | h.  |
|----------|-------|-----|
| 16114-20 | 20    | 4,0 |
| 16114-24 | 24    | 5,0 |
| 16114-28 | 28    | 5,0 |
| 16114-32 | 32    | 5,3 |
| 16114-36 | 36    | 6,0 |
| 16114-40 | 40    | 7,0 |



**French omelet pan**  
Tegame  
Servierpfanne  
Poêle à paella  
Paellera

| art.     | Ø cm. | h.  |
|----------|-------|-----|
| 16115-24 | 24    | 5,5 |
| 16115-28 | 28    | 6,0 |
| 16115-32 | 32    | 6,5 |
| 16115-36 | 36    | 7,0 |
| 16115-40 | 40    | 7,5 |
| 16115-45 | 45    | 7,5 |



**Cover**  
Coperchio  
Deckel  
Couvercle  
Tapa

| art.     | Ø cm. |
|----------|-------|
| 16961-16 | 16    |
| 16961-20 | 20    |
| 16961-24 | 24    |
| 16961-28 | 28    |
| 16961-32 | 32    |
| 16961-36 | 36    |
| 16961-40 | 40    |
| 16961-45 | 45    |
| 16961-50 | 50    |
| 16961-60 | 60    |







**Casserole pot, non stick**  
Casseruola alta, antiaderente  
Fleischtopf, nichttaftend  
Brasière, anti-adhérente  
Cacerola alta, antiadherente

| art.     | Ø cm. | h.   | lt.  |
|----------|-------|------|------|
| 16127-16 | 16    | 11,0 | 2,1  |
| 16127-20 | 20    | 13,0 | 4,0  |
| 16127-24 | 24    | 15,0 | 6,5  |
| 16127-28 | 28    | 17,5 | 10,8 |
| 16127-32 | 32    | 19,5 | 15,7 |
| 16127-36 | 36    | 21,0 | 21,5 |
| 16127-40 | 40    | 24,0 | 30,0 |



**Casserole pot, non stick**  
Casseruola bassa, antiaderente  
Bratentopf, nichttaftend  
Sautoir , anti-adhérente  
Cacerola baja, antiadherente

| art.     | Ø cm. | h.   | lt.  |
|----------|-------|------|------|
| 16120-24 | 24    | 9,5  | 4,3  |
| 16120-28 | 28    | 11,0 | 6,7  |
| 16120-32 | 32    | 12,5 | 10,0 |
| 16120-36 | 36    | 14,0 | 14,0 |
| 16120-40 | 40    | 16,0 | 20,0 |



**French omelet pan, non stick**  
Tegame, antiaderente  
Servierpfanne, nichttaftend  
Poêle à paella, anti-adhérente  
Paellera antiadherente

| art.     | Ø cm. | h.  |
|----------|-------|-----|
| 16116-28 | 28    | 6,5 |
| 16116-32 | 32    | 6,5 |
| 16116-36 | 36    | 7,0 |
| 16116-40 | 40    | 7,5 |



**Frypan, non stick**  
Padella, antiaderente  
Bratpfanne, nichttaftend  
Poêle, anti-adhérente  
Sartén antiadherente

| art.     | Ø cm. | h.  |
|----------|-------|-----|
| 41720-18 | 18    | 3,8 |
| 41720-20 | 20    | 3,8 |
| 41720-24 | 24    | 4,5 |
| 41720-28 | 28    | 5,4 |
| 41720-30 | 30    | 5,4 |
| 41720-32 | 32    | 5,6 |



**Frypan, non stick**  
Padella, antiaderente  
Bratpfanne, nichttaftend  
Poêle, anti-adhérente  
Sartén antiadherente

| art.     | Ø cm. | h.  |
|----------|-------|-----|
| 16117-20 | 20    | 4,0 |
| 16117-24 | 24    | 5,0 |
| 16117-28 | 28    | 5,0 |
| 16117-32 | 32    | 5,3 |
| 16117-36 | 36    | 6,0 |
| 16117-40 | 40    | 7,0 |



**INDUCTION  
READY!**

**Forged frypan, non stick**  
Padella forgiata, antiaderente  
Pfanne, geschmiedet, nichttaftend  
Poêle forgée, anti-adhérente  
Sartén forjada, antiadherente

| art.     | Ø cm. | h.  |
|----------|-------|-----|
| 11617-20 | 20    | 3,4 |
| 11617-24 | 24    | 4,2 |
| 11617-28 | 28    | 4,5 |
| 11617-32 | 32    | 5,5 |



**Frypan, non stick, cast iron handle**  
Padella bombata antiaderente, manico ferro  
Bratpfanne, nichttaftend, Gusseisen-Stiel  
Poêle bombé, anti-adhérente, queue fonte  
Sartén antiadherente, mango hierro

| art.     | Ø cm. | h.  |
|----------|-------|-----|
| 16113-20 | 20    | 5,5 |
| 16113-24 | 24    | 6,5 |
| 16113-28 | 28    | 7,0 |
| 16113-32 | 32    | 7,5 |
| 16113-36 | 36    | 8,0 |
| 16113-40 | 40    | 8,5 |



**Frypan, non stick, cast iron handle**  
Padella antiaderente, manico ferro  
Bratpfanne, nichttaftend, Gusseisen-Stiel  
Poêle, anti-adhérente, queue fonte  
Sartén antiadherente, mango hierro

| art.     | Ø cm. | h.  |
|----------|-------|-----|
| 16717-20 | 20    | 4,0 |
| 16717-24 | 24    | 5,0 |
| 16717-28 | 28    | 5,0 |
| 16717-32 | 32    | 5,3 |
| 16717-36 | 36    | 6,0 |
| 16717-40 | 40    | 7,0 |



**Crêpes pan, non stick**  
Padella crêpes, antiaderente  
Crêpepfanne, nichttaftend  
Poêle à crêpes, anti-adhérente  
Sartén crêpes antiadherente

| art.     | Ø cm. |
|----------|-------|
| 16118-24 | 24    |



**Non-stick blinis pan**

Padella per blini, antiaderente  
Blinis-Pfännchen, nichttaftend  
Poêle à blinis, anti-adhérente  
Sartén blinis, antiadherente

| art.     | Ø cm. | h. |
|----------|-------|----|
| 16719-12 | 12    | 2  |



**Crêpes pan, non-stick**

Padella crêpes antiaderente  
Crêpes-Pfanne, nichttaftend  
Tuile à crêpes anti-adhérente  
Sartén para crêpes, antiadherente

| art.     | Ø cm. |
|----------|-------|
| 16712-22 | 22    |
| 16712-26 | 26    |
| 16712-30 | 30    |



**Bake roasting pan**

Tegame  
Pfanne  
Plat à four  
Rustidera

| art.      | cm.   | h.  |
|-----------|-------|-----|
| 16941-40  | 40x26 | 7,5 |
| 16941-45  | 45x30 | 7,5 |
| 16941-50  | 50x30 | 8,0 |
| 16941-60  | 60x35 | 9,0 |
| 16941-61* | 61x43 | 9,0 |

\*For 2/1 GN ovens. – Per forno GN 2/1.



**Bake roasting pan**

Tegame  
Pfanne  
Plat à four  
Rustidera

| art.      | cm.   | h.  |
|-----------|-------|-----|
| 16943-40  | 40x26 | 7,5 |
| 16943-45  | 45x30 | 7,5 |
| 16943-50  | 50x30 | 8,0 |
| 16943-60  | 60x35 | 9,0 |
| 16943-61* | 61x43 | 9,0 |

\*For 2/1 GN ovens. – Per forno GN 2/1.



**Bake roasting, non stick**

Tegame, antiaderente  
Pfanne, nichttaftend  
Plat à four, anti-adhérente  
Rustidera antiadherente

| art.      | cm.   | h.  |
|-----------|-------|-----|
| 16947-40  | 40x26 | 7,5 |
| 16947-45  | 45x30 | 7,5 |
| 16947-50  | 50x30 | 8,0 |
| 16947-60  | 60x35 | 9,0 |
| 16947-61* | 61x43 | 9,0 |

\*For 2/1 GN ovens. – Per forno GN 2/1.



**Lid for roasting pans**

Coperchio per tegami  
Deckel für Bräter  
Couvercle pour plaques à rôtir  
Tapa para rustidera

| art.     | cm.   |
|----------|-------|
| 16948-40 | 40x26 |
| 16948-45 | 45x30 |
| 16948-50 | 50x30 |
| 16948-60 | 60x35 |
| 16948-61 | 61x43 |



**Bake roasting pan**

Tegame basso  
Pfanne, flach  
Plat à four bas  
Bandeja horno

| art.     | cm.   | h. |
|----------|-------|----|
| 16944-45 | 45x30 | 4  |
| 16944-50 | 50x30 | 4  |
| 16944-60 | 60x35 | 4  |



**Roasting pan with cover**

Brasiera con coperchio  
Brasiera mit Deckel  
Braisière avec couvercle  
Rustidera alta con tapa

| art.     | cm.   | h. | lt. |
|----------|-------|----|-----|
| 16965-40 | 40x26 | 15 | 14  |
| 16965-50 | 50x30 | 15 | 21  |
| 16965-60 | 60x35 | 15 | 30  |



**Fish kettle**

Pesciera  
Fisch-Kochkessel  
Poissonnière  
Hervidor pescado

| art.     | cm.   | h. | lt. |
|----------|-------|----|-----|
| 16939-50 | 50x15 | 12 | 9   |
| 16939-60 | 60x17 | 13 | 13  |
| 16939-70 | 70x19 | 14 | 18  |
| 16939-80 | 80x24 | 17 | 30  |



**Bain-marie pot**

Bagnomaria  
Wasserbadkasserolle  
Casserole bain-marie  
Baño maria

| art.     | Ø cm. | h. | lt. |
|----------|-------|----|-----|
| 16910-14 | 14    | 16 | 2,5 |
| 16910-16 | 16    | 18 | 3,7 |
| 16910-18 | 18    | 20 | 5,0 |
| 16910-20 | 20    | 22 | 7,0 |

Equipped with grid and cover. – Fornita con griglia e coperchio.



# STEEL FRYING PANS PADELLE FERRO



Iron is ideal for cooking at high temperatures because its low capacity of heat transmission prevents temperature leaps. As it is non-stick, food does not stick to it. It withstands very high temperatures and improves its performance with use. Iron pans are perfect for fried food, omelettes or fine crêpes. Wash the black iron pan in water as little as possible and always keep it greased. Iron pans are ideal also for cooking on induction hobs.

Il ferro è ottimo per le cotture a fuoco molto vivo perché, non avendo un'alta capacità di trasmettere calore, evita improvvisi sbalzi di temperatura. Essendo un materiale antiaderente, evita l'attaccamento dei cibi. Sopporta temperature elevatissime e col tempo migliora il suo rendimento. I recipienti in ferro sono i più adatti per frittare, omelette o sottili crêpes. La padella in ferro nera va lavata con acqua il meno possibile e mantenuta sempre unta. Il ferro è il materiale ideale anche per cotture a induzione.





**Blacksteel fish pan**  
Padella ovale  
Fischeisenpfanne, oval  
Coupe ovale  
Sartén oval

| art.     | cm.   | h.  |
|----------|-------|-----|
| 41719-36 | 36x26 | 5,0 |
| 41719-40 | 40x28 | 5,5 |



**Blacksteel crêpes pan**  
Padella crêpes  
Crêpes Eisenpfanne  
Coupe lyonnaise à crêpes  
Sartén crêpes

| art.     | Ø cm. | h. |
|----------|-------|----|
| 11718-20 | 20    | 2  |
| 11718-22 | 22    | 2  |
| 11718-24 | 24    | 2  |



**Blinis pan**  
Padella per blini  
Blinis-Eisenpfännchen  
Poêle à blinis  
Sartén blinis

| art.     | Ø cm. | h. |
|----------|-------|----|
| 11715-12 | 12    | 2  |



**Heavy blacksteel frypan**  
Padella lionese, pesante  
Schwere Eisenpfanne  
Coupe lyonnaise extra-forte  
Sartén honda pesada

| art.     | Ø cm. | h.  |
|----------|-------|-----|
| 11714-20 | 20    | 3,8 |
| 11714-22 | 22    | 4,0 |
| 11714-24 | 24    | 4,5 |
| 11714-26 | 26    | 4,5 |
| 11714-28 | 28    | 4,5 |
| 11714-32 | 32    | 5,0 |
| 11714-36 | 36    | 5,5 |
| 11714-40 | 40    | 5,5 |
| 11714-45 | 45    | 5,5 |
| 11714-50 | 50    | 6,0 |



**Blacksteel frypan**  
Padella lionese  
Eisenpfanne  
Coupe lyonnaise  
Sartén honda

| art.     | Ø cm. | h.  |
|----------|-------|-----|
| 11716-16 | 16    | 4,0 |
| 11716-20 | 20    | 4,5 |
| 11716-22 | 22    | 4,5 |
| 11716-24 | 24    | 5,0 |
| 11716-26 | 26    | 5,5 |
| 11716-28 | 28    | 5,5 |
| 11716-32 | 32    | 6,0 |
| 11716-36 | 36    | 6,5 |
| 11716-40 | 40    | 7,0 |
| 11716-45 | 45    | 8,0 |



**Blacksteel paella pan**  
Padella per paella  
Paella Eisenpfanne  
Coupe lyonnaise à paella  
Paellera

| art.     | Ø cm. | h.  |
|----------|-------|-----|
| 11717-34 | 34    | 5,0 |
| 11717-37 | 37    | 5,5 |
| 11717-42 | 42    | 6,0 |
| 11717-47 | 47    | 6,5 |
| 41717-60 | 60    | 6,5 |



**Blacksteel fish pan**  
Padella ovale  
Fischeisenpfanne, oval  
Coupe ovale  
Sartén oval

| art.     | cm.   |
|----------|-------|
| 41703-38 | 38x26 |



**Wok pan**  
Wok  
Wok-Pfanne  
Poêle chinoise  
Wok

| art.     | Ø cm. | h. |
|----------|-------|----|
| 11713-32 | 32    | 10 |
| 11713-40 | 40    | 11 |



**Chestnut pan**  
Padella per castagne  
Kastanienpfanne  
Poêle à marrons  
Sartén para castañas

| art.     | Ø cm. |
|----------|-------|
| 11721-28 | 28    |



**Silicone sleeve**  
Coprimanico silicone  
Silikon-Stielhülle  
Revêtement manche en silicone  
Cubre mango silicona

| art.     | Ø cm. | col. |
|----------|-------|------|
| 11710-AA | 20-36 | ●    |
| 11710-AB | 40-50 | ●    |

Heat resistant up to 230°C. Resistenza al calore fino a 230°C. Suits items! Per art: 16717, 16113, 16712, 11714, 11716, 11718, 11713, 11721.



**Fry pan**  
Padella per friggere  
Frittier-Pfanne  
Tuile à frire  
Sartén freidora

| art.     | Ø cm. | h.   | lt.  |
|----------|-------|------|------|
| 41707-32 | 32    | 9,8  | 6,0  |
| 41707-36 | 36    | 11,0 | 8,8  |
| 41707-40 | 40    | 13,4 | 12,2 |
| 41707-45 | 45    | 15,0 | 17,3 |
| 41707-50 | 50    | 17,6 | 23,5 |



**Wire basket, tinned**  
Cestello per friggere, stagnato  
Frittier-Rost, verzinkt  
Grille à frire, étamée  
Cesta escurrefrito, estañada

| art.     | Ø cm. | h.   |
|----------|-------|------|
| 41708-32 | 32    | 11,0 |
| 41708-36 | 36    | 11,5 |
| 41708-40 | 40    | 12,4 |
| 41708-45 | 45    | 15,5 |
| 41708-50 | 50    | 16,5 |

# SERIES 15500 3-PLY

COPPER COOKWARE  
PENTOLAME RAME

INDUCTION  
READY!



Ideal for cooking and serving from the kitchen to the table. A working tool with a body made of three metals, copper, aluminum and steel. A mix for a homogenous and sweet thermal spread that ensures cooking without attacking the foods, preserving its nutritional properties and organoleptic characteristics. Inside stainless steel, practical and easy to clean. Middle layer aluminum, lightweight and a very good heat conductor. Exterior glossy copper finishing, a tradition in the kitchen, fascinating and beautiful to see. Solid brass handles assembled with strong section rivets. Suitable for use on all cooking hobs including induction.

Ideale per cucinare e servire nello stesso recipiente. Uno strumento di lavoro con un corpo formato da tre metalli, rame, alluminio e acciaio. Un mix per un'omogenea e dolce diffusione termica che assicura una cottura senza aggredire i cibi, preservandone le proprietà nutrizionali e le caratteristiche organolettiche. Lamina interna in acciaio inox, pratico e facile da pulire. Strato intermedio in alluminio, leggero e ottimo conduttore di calore. Esterno in rame finitura lucida, una tradizione in cucina, affascinante e bello da vedere. Manici e maniglie in ottone massiccio assemblati con rivetti di forte sezione. Adatto ad uso su tutti i fuochi inclusa l'induzione.



**Saucepan**

Casseruola alta  
Stielkasserolle, hoch  
Casserole haute  
Cazo recto alto

| art.     | Ø cm. | h. | lt. |
|----------|-------|----|-----|
| 15506-16 | 16    | 8  | 1,6 |
| 15506-20 | 20    | 11 | 3,5 |
| 15506-24 | 24    | 14 | 6,3 |
| 15506-28 | 28    | 16 | 9,8 |



**Casserole pot**

Casseruola bassa  
Stielkasserolle, niedrig  
Sautoir  
Cacerola baja

| art.     | Ø cm. | h. | lt. |
|----------|-------|----|-----|
| 15508-20 | 20    | 7  | 2,2 |
| 15508-24 | 24    | 8  | 3,6 |
| 15508-28 | 28    | 9  | 5,5 |



**Frypan**

Padella  
Bratpfanne  
Poêle à frire  
Sartén

| art.     | Ø cm. | h.  | lt. |
|----------|-------|-----|-----|
| 15514-20 | 20    | 4,5 | 1,4 |
| 15514-24 | 24    | 4,5 | 2,0 |
| 15514-28 | 28    | 5,5 | 3,4 |
| 15514-32 | 32    | 6,0 | 4,8 |



**Saucepot**

Casseruola alta  
Fleischtopf  
Brasière  
Cacerola alta

| art.     | Ø cm. | h. | lt. |
|----------|-------|----|-----|
| 15507-16 | 16    | 8  | 1,6 |
| 15507-20 | 20    | 11 | 3,5 |
| 15507-24 | 24    | 14 | 6,3 |
| 15507-28 | 28    | 16 | 9,8 |



**Casserole pot**

Casseruola bassa  
Bratentopf  
Sautoir  
Cacerola baja

| art.     | Ø cm. | h. | lt. |
|----------|-------|----|-----|
| 15509-20 | 20    | 7  | 2,2 |
| 15509-24 | 24    | 8  | 3,6 |
| 15509-28 | 28    | 9  | 5,5 |



**Frypan**

Padella  
Bratpfanne  
Poêle à paella  
Paellera

| art.     | Ø cm. | h.  | lt. |
|----------|-------|-----|-----|
| 15515-20 | 20    | 4,5 | 1,4 |
| 15515-24 | 24    | 4,5 | 2,0 |
| 15515-28 | 28    | 5,5 | 3,4 |
| 15515-32 | 32    | 6,0 | 4,8 |



**Cover**

Coperchio  
Deckel  
Couvercle  
Tapa

| art.     | Ø cm. |
|----------|-------|
| 15561-20 | 20    |
| 15561-24 | 24    |
| 15561-28 | 28    |





# MINI COOKWARE MINIATURE SERIES 15200

**COPPER COOKWARE 3-PLY**  
PENTOLAME RAME 3-PLY



**Paderno Serie 15200 3-ply, inside stainless steel satin polished, intermediate layer in aluminum, outside copper mirror polished. Thickness 1,8 mm. Stainless steel handles with PVD gold finishing, stainless steel rivets. For use on any heating element (except on induction hob).**

Serie Paderno 15200 3-ply, lamina interna in acciaio inox finitura satinata, strato intermedio in alluminio, esterno rame lucido. Spessore 1,8 mm. Manicatura in acciaio inox con finitura PVD oro, rivetti inox. Adatte ad uso su tutti i fuochi (eccetto induzione).



#### Saucepan

Casseruola alta  
Stielkasserolle, hoch  
Casserole haute  
Cazo recto alto

| art.     | Ø cm. | h.  | lt.  |
|----------|-------|-----|------|
| 15226-07 | 7     | 4,0 | 0,15 |
| 15228-10 | 10    | 4,5 | 0,35 |



#### Saucepan

Casseruola alta  
Stielkasserolle, hoch  
Casserole haute  
Cazo recto alto

| art.     | Ø cm. | h. | lt.  |
|----------|-------|----|------|
| 15226-10 | 10    | 7  | 0,50 |
| 15226-12 | 12    | 8  | 0,85 |
| 15226-14 | 14    | 9  | 1,30 |



#### Frypan

Padella  
Bratpfanne  
Poêle à paella  
Paellera

| art.     | Ø cm. | h.  | lt.  |
|----------|-------|-----|------|
| 15224-10 | 10    | 3,0 | 0,20 |
| 15224-12 | 12    | 3,5 | 0,35 |
| 15224-14 | 14    | 4,5 | 0,70 |



#### Saucepot

Casseruola alta  
Fleischtopf  
Brasière  
Cacerola alta

| art.     | Ø cm. | h. | lt.  |
|----------|-------|----|------|
| 15227-10 | 10    | 7  | 0,50 |
| 15227-12 | 12    | 8  | 0,85 |
| 15227-14 | 14    | 9  | 1,30 |



#### Casserole pot

Casseruola bassa  
Bratentopf  
Sautoir  
Cacerola baja

| art.     | Ø cm. | h.  | lt.  |
|----------|-------|-----|------|
| 15229-10 | 10    | 4,5 | 0,35 |



#### Omelet pan

Tegame  
Servierpfanne  
Poêle à paella  
Paellera

| art.     | Ø cm. | h.  | lt.  |
|----------|-------|-----|------|
| 15225-10 | 10    | 3,0 | 0,20 |
| 15225-12 | 12    | 3,5 | 0,35 |
| 15225-14 | 14    | 4,5 | 0,70 |



#### Cover

Coperchio  
Deckel  
Couvercle  
Tapa

| art.     | Ø cm. |
|----------|-------|
| 15261-10 | 10    |
| 15261-12 | 12    |
| 15261-14 | 14    |





# SERIES 15300-15400

COPPER COOKWARE  
PENTOLAME RAME



Solid copper, thickness from 1,5 to 2,5 mm, the interiors are tinned over the fire by hand. Handles in highly polished solid brass, assembled with wide rivets. For use on any heating element (except on induction hob).

Rame massiccio, spessore da 1,5 a 2,5 mm internamente stagnato a mano sulla fiamma. Manici e maniglie in ottone massiccio lucidato a specchio ed assemblati con rivetti di forte sezione. Adatto ad uso su tutti i fuochi (eccetto induzione).



**Oval saucepan**  
Casseruola ovale  
Ovaler Bratentopf  
Casserole ovale  
Cacerola oval

| art.     | cm.   | h. |
|----------|-------|----|
| 15338-38 | 38x25 | 13 |



**Bake roasting pan**  
Tegame rettangolare  
Rechteckige Pfanne  
Plat à four  
Rustidera

| art.     | cm.   | h. |
|----------|-------|----|
| 15343-36 | 38x28 | 11 |



**Oval pan**  
Tegame ovale  
Ovale Bratpfanne  
Plat ovale à poignées  
Bandeja oval

| art.     | cm.   | h. |
|----------|-------|----|
| 15339-36 | 38x26 | 11 |



**Fish kettle**  
Pesciera  
Fischkochkessel  
Poissonnière  
Hervidor pescado

| art.     | cm.   | h. |
|----------|-------|----|
| 15438-50 | 50x18 | 11 |



**Bain-marie**  
Bagnomaria  
Wasserbadkasserolle  
Bain-marie  
Baño maría

| art.     | Ø cm. | h. |
|----------|-------|----|
| 15403-16 | 16    | 17 |

**With porcelain. – Con porcellana.**



**Fondue set**  
Set fonduta  
Fondue-Service  
Service à fondue  
Servicio para fondues

| art.     | Ø cm. | h. |
|----------|-------|----|
| 15430-11 | 16    | 26 |



**Sugar saucepan**  
Casseruola per zucchero  
Zuckerpfännchen  
Poelon à sucre  
Cacerola para azúcar

| art.     | Ø cm. | h. |
|----------|-------|----|
| 15406-16 | 16    | 9  |
| 15406-20 | 20    | 10 |



**Zabaione bowl**  
Casseruola per zabaione  
Zabaionekasserolle  
Poelon à zabaione  
Cacerola sabayón

| art.     | Ø cm. |
|----------|-------|
| 15407-16 | 16    |
| 15407-20 | 20    |



**Foot for zabaione bowl**  
Base per casseruola zabaione  
Fuss für Zabaionekasserolle  
Base pour poelon à zabaione  
Base para cacerola sabayón

| art.     | Ø cm. | h.  |
|----------|-------|-----|
| 15401-51 | 8     | 4,5 |



**Mixing bowl**  
Bastardella semisferica  
Schnees Schlagkessel  
Bassine hémisphérique  
Caldero

| art.     | Ø cm. |
|----------|-------|
| 15409-26 | 26    |
| 15409-30 | 30    |
| 15409-36 | 36    |

**Frosted finishing. – Finitura smerigliata.**



**Bordelais moulds**  
Stampo scanalato  
Bordelais-Kuchenform  
Moule à cannelés Bordelais  
Molde para bordelais

| art.     | Ø cm. | h. mm. |
|----------|-------|--------|
| 15415-03 | 5,5   | 5      |

**3 pcs set. – Set 3 pezzi.**







# MINI COOKWARE MINIATURE

COOKWARE  
PENTOLAME



Aluminum body non-stick coated, brass handles. A range of small pots ideal for side dishes and individual servings, soufflés, baked pasta, rice creams, raclette, savory as well as sweet pastries, desserts, etc., etc.. Versatile, functional, ready to be served from the kitchen to the table. Original and yet traditional, they come from the world of haute cuisine, ideal for enhancing creations or the most simple recipes, for the sake of conviviality, to give a more playful aspect to our meals.

Corpo in alluminio con rivestimento antiaderente, maniciatura in ottone. Una gamma di miniature ideali per contorni e singole porzioni, soufflé, pasta al forno, creme di riso, raclette, brioches salate e dolci, dessert, ecc., ecc.. Polivalenti, funzionali, pronte per essere servite dalla cucina alla tavola. Originali eppure tradizionali, provengono dal mondo dell'alta gastronomia, strumento ideale per valorizzare creazioni estrose o le più semplici ricette, per amore della convivialità, per donare un aspetto più ludico ai nostri pasti.



## Saucepan

Casseruola alta  
Stielkasserole, hoch  
Casserole haute  
Cazo recto alto

| art.     | Ø cm. | h. | lt.  |
|----------|-------|----|------|
| 16136-10 | 10    | 6  | 0,45 |



## Sauté pan

Casseruola bassa  
Stielkasserole, niedrig  
Plat à sauter  
Cazo recto bajo

| art.     | Ø cm. | h. | lt. |
|----------|-------|----|-----|
| 16138-10 | 10    | 4  | 0,3 |



## Frypan

Padella  
Bratpfanne  
Poêle à frir  
Sartén

| art.     | Ø cm. | h. | lt. |
|----------|-------|----|-----|
| 16134-12 | 12    | 4  | 0,4 |



## Saucepan

Casseruola alta  
Fleischtopf  
Casserole haute  
Cazo recto alto

| art.     | Ø cm. | h. | lt.  |
|----------|-------|----|------|
| 16137-10 | 10    | 6  | 0,45 |



## Casserole pot

Casseruola bassa  
Bratentopf  
Sautoir  
Cacerola baja

| art.     | Ø cm. | h. | lt. |
|----------|-------|----|-----|
| 16139-10 | 10    | 4  | 0,3 |



## French omelet pan

Tegamino  
Servierpfanne  
Poêle à paella  
Paellera

| art.     | Ø cm. | h. | lt. |
|----------|-------|----|-----|
| 16135-12 | 12    | 4  | 0,4 |





**Blinis pan, non-stick aluminum**

Padella blini, alluminio antiaderente  
Blinis-Pfännchen, Alu-Nichttaftend  
Poêle à blinis, alu anti-adhérente  
Sartén blinis, aluminio antiadherente

| art.     | Ø cm. | h. |
|----------|-------|----|
| 16719-12 | 12    | 2  |



**Blinis pan, steel**

Padella blini, ferro  
Blinis-Pfännchen, Eisen  
Poêle à blinis, acier  
Sartén blinis, hierro

| art.     | Ø cm. | h. |
|----------|-------|----|
| 11715-12 | 12    | 2  |



**Sauté pan with double spouts**

Casseruola con due becchi, 3-ply  
Stielkasserolle, niedrig, 2 Schnabel  
Plat à sauter, 2 becs  
Cazo recto bajo, 2 picos

| art.     | Ø cm. | h. | lt. |
|----------|-------|----|-----|
| 12511-10 | 10    | 5  | 0,4 |

**Mirror finishing. – Finitura lucida.**



**Sauté pan**

Casseruola bassa, 3-ply  
Stielkasserolle, niedrig  
Plat à sauter  
Cazo recto bajo

| art.     | Ø cm. | h. | lt. |
|----------|-------|----|-----|
| 12511-12 | 12    | 6  | 0,7 |

**Mirror finishing. – Finitura lucida.**



**Sauté pan**

Casseruola bassa, 3-ply  
Stielkasserolle, niedrig  
Plat à sauter  
Cazo recto bajo

| art.     | Ø cm. | h. | lt. |
|----------|-------|----|-----|
| 12511-14 | 14    | 7  | 1   |

**Mirror finishing. – Finitura lucida.**



**Saucepot with lid**

Casseruola con coperchio, 3-ply  
Fleischtopf mit Deckel  
Brasière avec couvercle  
Cacerola alta con tapa

| art.     | Ø cm. | h. | lt. |
|----------|-------|----|-----|
| 12509-12 | 12    | 6  | 0,7 |

**Mirror finishing. – Finitura lucida.**



**Saucepan, oval, Stoneware**

Casseruola ovale  
Kasserolle, oval  
Casserole, ovale  
Cacerola, oval

| art.     | cm.    | h.  |
|----------|--------|-----|
| 41210-03 | 13x8,2 | 3,9 |



**Saucepan, Stoneware**

Tegamimo  
Pfännchen  
Sautoir  
Fuente huevo

| art.     | Ø cm. | h. |
|----------|-------|----|
| 41210-12 | 13    | 5  |
| 41210-13 | 15    | 5  |
| 41210-14 | 17    | 5  |



**Saucepan, rectangular, Stoneware**

Casseruola rettangolare  
Kasserolle, rechteckig  
Casserole, rectangulaire  
Cacerola, rectangular

| art.     | cm.    | h.  |
|----------|--------|-----|
| 41210-05 | 13x8,2 | 3,9 |



**Piepan, Stoneware**

Tortiera  
Kuchenform  
Ramequin  
Molde tarta

| art.     | Ø cm. | h.  |
|----------|-------|-----|
| 41210-10 | 11    | 3,9 |



**Saucepan, round, Stoneware**

Casseruola tonda  
Kasserolle, rund  
Casserole, ronde  
Cacerola, redonda

| art.     | Ø cm. | h.  |
|----------|-------|-----|
| 41210-01 | 13    | 3,9 |



**Saucepan with lid, Stoneware**

Casseruola con coperchio  
Kasserolle mit Deckel  
Casserole avec couvercle  
Cacerola con tapa

| art.     | Ø cm. | h.  |
|----------|-------|-----|
| 41210-07 | 11,5  | 5,5 |
| 41210-08 | 13,0  | 7,5 |

# ENAMELLED CAST IRON GHISA SMALTATA

COOKWARE  
PENTOLAME



Suitable for use on all cooking hobs (gas, electric, ceramic, induction) and ovens (gas, oil, coal or wood) except microwave. A perfect harmony of cast iron, enamel and high quality. Designed and constructed to absorb and spread the heat evenly. Cast iron is suitable for all cooking techniques, for soups, roasts, rice, desserts, for braise that require a long cooking and likewise ideal for meats and grilled vegetables as it enhances flavors and aromas like barbecue style. Cast iron also features non-stick. The high temperature of the pan sears the meat surface. All the flavor, water and nutritional values remain sealed in the food. When cooking in casseroles, the steam generated thanks to the special design of the cover condenses falling back into the food not only retaining flavors and aromas but providing the best protection for nutrients and contributing to a healthy diet. Cast iron is a material 100% recyclable and therefore environmentally friendly. Moreover, thanks to its ability to retain heat for a long time it allows a considerable saving of energy. With closed lid on the table, the pot will preserve the temperature for a second serving. Cast iron retains the heat but as well the cold... can be used to keep the food fresh. Stored for a short time in the refrigerator, keeps food cool during hot summer days, ideal for serving pasta or rice salads, etc. Practical and easy to clean. These cast iron pots and pans are dishwasher safe thanks to the special technology applied to their enameling method. Ergonomic knobs and handles made of cast iron and stainless steel, suitable for use on all heat sources and ovens except microwave. Be careful, they heat up during cooking, it is recommended to handle with a dry thick cloth.

Idonee all'uso su tutte le fonti di cottura (gas, elettriche, vetroceramica, induzione) e forni (gas, petrolio, carbone o legna) ad esclusione di microonde. Una perfetta armonia tra ghisa, smalto e alta qualità. Progettate e costruite per assorbire e diffondere il calore in modo uniforme. La ghisa è adatta a tutte le tecniche di cottura, per zuppe, arrostiti, risotti, dolci, per piatti che richiedono una lunga cottura tipo brasati e allo stesso modo ideale per carni e verdure alla griglia in quanto ne esalta sapori ed aromi in stile barbecue. La ghisa ha anche caratteristiche di antiaderenza. La temperatura elevata della padella cauterizza la superficie della carne. Tutto il sapore, l'acqua e i valori nutrizionali rimangono sigillati nel cibo. Nella cottura in casseruole, il vapore generato grazie al particolare design del coperchio si condensa ricadendo e mescolandosi nuovamente nel cibo non solo trattenendo sapori e aromi ma fornendo la miglior protezione alle sostanze nutrienti e contribuendo ad una dieta sana. La ghisa è un materiale riciclabile al 100% e quindi ecologico. Inoltre, grazie alla sua capacità di mantenere il calore per lungo tempo consente un notevole risparmio di energia permettendo di cuocere a fuoco basso. Anche a tavola mantengono in cibi in temperatura. La ghisa mantiene però il caldo come pure il freddo... può essere usata per mantenere il cibo fresco. Riposta per un breve periodo in frigorifero, mantiene il cibo fresco nelle calde giornate estive e ideale per servire insalate di pasta, riso, farro, ecc., ecc. Pratica e facile da pulire. Queste casseruole e padelle in ghisa sono lavabili in lavastoviglie, per merito della speciale tecnologia applicata al metodo di smaltatura. Manicatura e pomoli dal design ergonomico sono in ghisa e inox. Durante la cottura si raccomanda di maneggiare con un panno consistente e asciutto per evitare di scottarsi.



**Saucepot round with lid**  
Casseruola tonda con coperchio  
Fleischtopf, rund mit Deckel  
Brasière avec couvercle  
Cacerola redonda con tapa

| art.     | Ø cm. | lt.  | col. |
|----------|-------|------|------|
| 44201R10 | 10    | 0,35 | ●    |
| 44201V10 | 10    | 0,35 | ●    |
| 44201B10 | 10    | 0,35 | ●    |
| 44201O10 | 10    | 0,35 | ●    |
| 44201N10 | 10    | 0,35 | ●    |

**Portion:** – Porzioni: 1



**Saucepot round with lid**  
Casseruola tonda con coperchio  
Fleischtopf, rund mit Deckel  
Brasière avec couvercle  
Cacerola redonda con tapa

| art.     | Ø cm. | lt.  | col. |
|----------|-------|------|------|
| 44201R12 | 12    | 0,55 | ●    |
| 44201V12 | 12    | 0,55 | ●    |
| 44201B12 | 12    | 0,55 | ●    |
| 44201O12 | 12    | 0,55 | ●    |
| 44201N12 | 12    | 0,55 | ●    |

**Portion:** – Porzioni: 1



**Oval saucepan with lid**  
Casseruola ovale con coperchio  
Ovaler Bratentopf mit Deckel  
Casserole ovale avec couvercle  
Cacerola oval con tapa

| art.     | cm.    | col. |
|----------|--------|------|
| 44202R12 | 12x9x6 | ●    |
| 44202N12 | 12x9x6 | ●    |

**Portion:** – Porzioni: 1



**Saucepot stand**  
Supporto casseruolina  
Fleischtopf-Träger  
Support pour brasière  
Soporte para cacerola

| art.     | Ø cm. |
|----------|-------|
| 44201-01 | 10    |

W



**Saucepot stand**  
Supporto casseruolina  
Fleischtopf-Träger  
Support pour brasière  
Soporte para cacerola

| art.     | Ø cm. |
|----------|-------|
| 44201-03 | 10    |

W



**Saucepot platter**  
Sottopentola  
Fleischtopfbrett  
Planche à casserole  
Tabla para cacerola

| art.     | Ø cm. |
|----------|-------|
| 44201-10 | 10-12 |

W



**Saucepot platter**  
Sottopentola  
Fleischtopfbrett  
Planche à casserole  
Tabla para cacerola

| art.     | cm.  |
|----------|------|
| 44202-10 | 12x9 |

W



**Soufflé pot with wooden platter**  
Coppa soufflé con piatto legno  
Ramekin mit Holzbrett  
Ramequin avec planche bois  
Fuente soufflé con tabla madera

| art.     | Ø cm. | lt.  |
|----------|-------|------|
| 44240S08 | 8     | 0,17 |

**Portion:** – Porzioni: 1



**Platter with magnetic feature**  
Sottopentola magnetico  
Untersetzer, magnetisch  
Sous-plat magnétique  
Posavasos magnético

| art.     | Ø cm. |
|----------|-------|
| 44207-20 | 20    |

W



**Silicone sleeves**  
Coprigraniglie silicone  
Silikon-Griffhüllen  
Revêtement en silicone pour poignées  
Cubre asas de silicona

| art.     | col. |
|----------|------|
| 44208G00 | ●    |
| 44208R00 | ●    |



**Saucepot with lid**  
Casseruola alta con coperchio  
Fleischtopf mit Deckel  
Brasière avec couvercle  
Cacerola alta con tapa

| art.     | Ø cm. | lt.  | Por.  |
|----------|-------|------|-------|
| 44201R16 | 16    | 1,0  | 1-2   |
| 44201R20 | 20    | 2,6  | 2-3   |
| 44201R24 | 24    | 4,5  | 4-5   |
| 44201R28 | 28    | 6,7  | 6-8   |
| 44201R32 | 32    | 10,0 | 12-16 |





**Saucepot with lid**

Casseruola alta con coperchio  
Fleischtopf mit Deckel  
Brasière avec couvercle  
Cacerola alta con tapa

| art.     | Ø cm. | lt.  | Por.  |
|----------|-------|------|-------|
| 44201N16 | 16    | 1,0  | 1-2   |
| 44201N20 | 20    | 2,6  | 2-3   |
| 44201N24 | 24    | 4,5  | 4-5   |
| 44201N28 | 28    | 6,7  | 6-8   |
| 44201N32 | 32    | 10,0 | 12-16 |



**Oval saucepan with lid**

Casseruola ovale con coperchio  
Ovaler Bratentopf mit Deckel  
Casserole ovale avec couvercle  
Cacerola oval con tapa

| art.     | Ø cm. | lt. | Por. |
|----------|-------|-----|------|
| 44202R29 | 29    | 4,8 | 6    |



**Oval saucepan with lid**

Casseruola ovale con coperchio  
Ovaler Bratentopf mit Deckel  
Casserole ovale avec couvercle  
Cacerola oval con tapa

| art.     | Ø cm. | lt. | Por. |
|----------|-------|-----|------|
| 44202N25 | 25    | 3,3 | 4    |
| 44202N29 | 29    | 4,8 | 6    |



**Casserole pot with glass lid**

Casseruola bassa coperchio vetro  
Bratentopf mit Glasdeckel  
Sautoir avec couvercle verre  
Cacerola baja con tapa vidrio

| art.     | Ø cm. | lt. | Por. |
|----------|-------|-----|------|
| 44204R24 | 24    | 2,4 | 4    |
| 44204R28 | 28    | 3,4 | 4-6  |



**Grill pan**

Padella grill  
Grill-Pfanne  
Poêle grill  
Sartén grill

| art.     | cm.   | lt. | Por. |
|----------|-------|-----|------|
| 44209R26 | 26x26 | 2,2 | 4    |
| 44209R32 | 26x32 | 2,6 | 6    |



**Grill pan**

Padella grill  
Grill-Pfanne  
Poêle grill  
Sartén grill

| art.     | cm.   | lt.  | Por. |
|----------|-------|------|------|
| 44210-26 | 26x26 | 2,20 | 4    |
| 44210-32 | 26x32 | 2,75 | 6    |



**Grill pan with wooden service stand**

Padella grill con tagliere a servire legno  
Grill-Pfanne mit Service-Holzbrett  
Poêle grill avec support à servir bois  
Sartén grill con tabla madera

| art.     | cm.   | lt.  | Por. |
|----------|-------|------|------|
| 44210S32 | 26x32 | 2,75 | 6    |



**Grill pan**

Padella grill  
Grill-Pfanne  
Poêle grill  
Sartén grill

| art.     | cm.   | lt. | Por. |
|----------|-------|-----|------|
| 44210-42 | 31x42 | 4,5 | 8    |



**Bake roasting dish**

Tegame rettangolare  
Pfanne, rechteckig  
Plat rectangulaire  
Rustidera

| art.     | cm.   | Por. |
|----------|-------|------|
| 44218R30 | 22x30 | 6-8  |
| 44218R40 | 26x40 | 8-12 |



**Terrine pot**

Terrina  
Pasteten-Pfanne  
Terrine rectangle  
Fuente rectangular

| art.     | cm.        | Por. |
|----------|------------|------|
| 44219R26 | 8,5x26,5x6 | 2-4  |



**Grill pan**

Bistecchiera  
Grill-Pfanne  
Poêle grill  
Sartén grill

| art.     | cm.   | Por. |
|----------|-------|------|
| 44213-24 | 24x24 | 1-2  |
| 44213-36 | 21x36 | 2-4  |





**Grill pan**

Bistecchiera  
Grill-Pfanne  
Poêle grill  
Sartén grill

| art.     | Ø cm. | Por. |
|----------|-------|------|
| 44214-25 | 25    | 2-3  |



**Grill pan**

Bistecchiera  
Grill-Pfanne  
Poêle grill  
Sartén grill

| art.     | Ø cm. | lt.  | Por. |
|----------|-------|------|------|
| 44212-30 | 30    | 2,35 | 4-6  |



**Griddle plate, dual side, reversible**

Griglia reversibile  
Grill-Platte, zweiseitig, reversible  
Grill rectangle, reversible  
Parrilla reversible

| art.     | cm.   | Por. |
|----------|-------|------|
| 44224-22 | 22x15 | 1-2  |



**Griddle plate, dual side, reversible**

Griglia reversibile  
Grill-Platte, zweiseitig, reversible  
Grill rectangle, reversible  
Parrilla reversible

| art.     | cm.   | Por. |
|----------|-------|------|
| 44217-45 | 26x47 | 6-8  |



**Grill plate and wooden platter**

Griglia reversibile con tagliere legno  
Grill-Platte mit Service-Holzbrett  
Grill avec plache à servir bois  
Parrilla con tabla madera

| art.     | cm.   | Por. |
|----------|-------|------|
| 44224S22 | 22x15 | 1-2  |



**Griddle with wooden platter**

Griglia con tagliere legno  
Grill-Platte mit Holzbrett  
Grill rectangle avec planche bois  
Parrilla con tabla madera

| art.     | cm.   | Por. |
|----------|-------|------|
| 44226S30 | 22x30 | 2-3  |



**Table barbecue**

Barbecue da tavola  
Tischgrillplatte  
Barbecue de table  
Parrilla de mesa

| art.     | cm.   | Por. |
|----------|-------|------|
| 44227-30 | 22x30 | 2-3  |



**Table barbecue**

Barbecue da tavola  
Tischgrillplatte  
Barbecue de table  
Parrilla de mesa

| art.     | cm.   | Por. |
|----------|-------|------|
| 44225-22 | 22x15 | 1-2  |



**Grill pan and wooden service stand**

Padella grill con tagliere a servire legno  
Grill-Pfanne mit Service-Holzbrett  
Poêle grill avec plache à servir bois  
Sartén grill con tabla madera

| art.     | cm.   | Por. |
|----------|-------|------|
| 44216S16 | 16x16 | 1    |

**Cups not included. – Ciotoline non incluse.**



**Grill pan with wooden platter**  
Padella grill con tagliere legno  
Grill-Pfanne mit Holzbrett  
Poêle grill avec plaque bois  
Sartén grill con tabla madera

| art.     | cm.   | Por. |
|----------|-------|------|
| 44215S16 | 16x16 | 1    |



**Fish plate with wooden platter**  
Piatto pesce con tagliere legno  
Fischplatte mit Holzbrett  
Plat à poisson avec planche bois  
Fuente pescado con tabla madera

| art.     | cm.       | Por. |
|----------|-----------|------|
| 44221S30 | 15,5x29,5 | 1-2  |



**Fish plate with wooden platter**  
Piatto pesce con tagliere legno  
Fischplatte mit Holzbrett  
Plat à poisson avec planche bois  
Fuente pescado con tabla madera

| art.     | cm.   | Por. |
|----------|-------|------|
| 44220S24 | 15x24 | 1-2  |



**Pizza pan with wooden platter**  
Piatto pizza con tagliere legno  
Pizza-Platte mit Holzbrett  
Plat à pizza avec planche bois  
Fuente para pizza con tabla madera

| art.     | Ø cm. | Por. |
|----------|-------|------|
| 44222S20 | 20    | 1    |
| 44222S28 | 28    | 1    |



**Fajita plate with wooden platter**  
Piatto fajita con tagliere legno  
Fajitaplatte mit Holzbrett  
Plat à fajitas avec planche bois  
Fuente fajitas con tabla madera

| art.     | cm.   | Por. |
|----------|-------|------|
| 44228S23 | 17x23 | 1    |



**Oval plate with wooden platter**  
Piatto ovale con tagliere legno  
Ovalplatte mit Holzbrett  
Plat oval avec planche bois  
Fuente ovale con tabla madera

| art.     | cm.       | Por. |
|----------|-----------|------|
| 44230S14 | 21x14x2,5 | 1-2  |



**Round plate with wooden platter**  
Piatto tondo con tagliere legno  
Platte mit Holzbrett, rund  
Plat rond avec planche bois  
Fuente redonda con tabla madera

| art.     | Ø cm. | Por. |
|----------|-------|------|
| 44232S16 | 16    | 1-2  |
| 44232S20 | 20    | 2-3  |



**Round plate with wooden platter**  
Piatto tondo con tagliere legno  
Platte mit Holzbrett, rund  
Plat rond avec planche bois  
Fuente redonda con tabla madera

| art.     | Ø cm. | lt.  | Por. |
|----------|-------|------|------|
| 44233-20 | 20    | 0,74 | 3-4  |

**Cups not included. – Ciotoline non incluse.**



**Round pan**  
Padella tonda  
Pfanne, rund  
Poêle ronde  
Sartén grill redonda

| art.     | Ø cm. | Por. |
|----------|-------|------|
| 44234-12 | 12    | 1    |
| 44234-16 | 16    | 1-2  |



**Pan and wooden platter**  
Padella con tagliere legno  
Pfanne mit Holzbrett  
Poêle avec planche bois  
Sartén grill con tabla madera

| art.     | Ø cm. | lt.  | Por. |
|----------|-------|------|------|
| 44234S16 | 16    | 0,45 | 1-2  |



**Rectangular pan with wooden service stand**

Tegame con tagliere a servire legno  
Pfanne mit Service-Holzbrett  
Poêle avec support à servir bois  
Sartén con tabla madera

| art.     | cm.   | Por. |
|----------|-------|------|
| 44237S15 | 12x15 | 1-2  |



**Service dish with wooden stand**

Piatto servire con tagliere legno  
Servierplatte mit Holzbrett  
Plat à servir avec support en bois  
Plato para servir con tabla madera

| art.     | cm.   | Por. |
|----------|-------|------|
| 44245S32 | 32x20 | 1    |



**Service dish with wooden stand**

Piatto servire con tagliere legno  
Servierplatte mit Holzbrett  
Plat à servir avec support en bois  
Plato para servir con tabla madera

| art.     | cm.   | Por. |
|----------|-------|------|
| 44244S36 | 36x24 | 4-6  |



**Pan with wooden platter**

Tegame con tagliere legno  
Pfanne mit Holzbrett  
Poêle avec plache bois  
Paellera con tabla madera

| art.     | Ø cm. | cm.       | lt.  | Por. |
|----------|-------|-----------|------|------|
| 44247S16 | 16    | 23,5x18,5 | 0,44 | 1-2  |



**Hot pot with wooden stand**

Casseruola con tagliere legno  
Schüssel mit Holzbrett  
Bol avec support en bois  
Bol con tabla madera

| art.     | Ø cm. | h. | lt.  | Por. |
|----------|-------|----|------|------|
| 44246S14 | 14    | 4  | 0,32 | 1    |
| 44246S17 | 17    | 4  | 0,59 | 1    |



**Tortillas cup**

Ciotola tortillas  
Tortillas-Schale  
Coupe-tortillas  
Copa tortillas

| art.     | Ø cm. |
|----------|-------|
| 44241-19 | 19    |

**W**



**Soufflé pot, enameled cast iron**

Coppa soufflé, ghisa smaltata  
Ramekin, emailliertes Gusseisen  
Ramequin, fonte émaillée  
Fuente soufflé, hierro fundido esmaltado

| art.     | Ø cm. | lt.  | Por. |
|----------|-------|------|------|
| 44240-08 | 8     | 0,15 | 1    |



**PR**

**Sauce bowl**

Coppa salsa  
Saucentasse  
Bol à sauce  
Copa para salsa

| art.     | Ø cm. | h.  |
|----------|-------|-----|
| 44242-00 | 6     | 2,7 |



**MF**

**Sauce bowl**

Coppa salsa  
Saucentasse  
Bol à sauce  
Copa para salsa

| art.     | Ø cm. | h.  |
|----------|-------|-----|
| 44243-00 | 7,1   | 3,5 |





# OVEN COOKING DISHES PIROFILE FORNO

PORCELAIN  
PORCELLANA



Only use in the oven or microwave oven, do not place them on direct flame.

Per uso in forni tradizionali e microonde, non mettere le porcellane a diretto contatto con la fiamma.





**Oval dish, fluted**

Pirofila ovale cordonata  
Schale, oval, gerippt  
Plat ovale, cannelé  
Fuente oval borderizata

| art.     | cm.         |
|----------|-------------|
| 44371-24 | 24x14x4     |
| 44371-28 | 28x16x4,5   |
| 44371-32 | 32,5x18x5   |
| 44371-36 | 36,5x19,5x5 |
| 44371-40 | 41x23x5,5   |
| 44371-44 | 44x26,5x5,7 |
| 44371-48 | 48x28,5x6,5 |



**Round dish, fluted**

Pirofila rotonda cordonata  
Schale, rund, gerippt  
Plat rond, cannelé  
Fuente redonda borderizata

| art.     | Ø cm. |
|----------|-------|
| 44372-26 | 26,5  |
| 44372-32 | 32,0  |
| 44372-36 | 36,0  |
| 44372-40 | 40,0  |



**Rectangular dish, fluted**

Pirofila rettangolare cordonata  
Schale, rechteckig, gerippt  
Plat rectangulaire, cannelé  
Fuente rectangular borderizata

| art.     | cm.     |
|----------|---------|
| 44374-22 | 22x16x6 |
| 44374-25 | 25x20x7 |
| 44374-32 | 32x22x6 |
| 44374-36 | 36x24x6 |
| 44374-40 | 40x26x6 |
| 44374-44 | 44x32x6 |



**Oval dish, high, fluted**

Pirofila ovale cordonata, alta  
Schale, oval, gerippt  
Plat oval, cannelé  
Fuente oval borderizata, alta

| art.     | cm.       |
|----------|-----------|
| 44389-32 | 32x22x8,5 |



**Rectangular dish, low, fluted**

Rettangolare cordonata, bassa  
Schale, rechteckig, flach, gerippt  
Plat rectangulaire, cannelé  
Fuente rect. borderizata, baja

| art.     | cm.     |
|----------|---------|
| 44376-40 | 40x30x4 |



**Square dish, fluted**

Pirofila quadra cordonata  
Schale, quadratisch, gerippt  
Plat carré, cannelé  
Fuente cuadrada borderizata

| art.     | cm.     |
|----------|---------|
| 44375-25 | 25x25x6 |



**Egg dish, fluted**

Tegamino cordonato  
Schale, gerippt  
Plat à oeufs, cannelé  
Fuente huevo borderizata

| art.     | cm.     |
|----------|---------|
| 44394-18 | 18x21,0 |
| 44394-21 | 21x24,5 |



**Creme broulée bowl**

Coppetta creme broulée  
Crème broulée Schale  
Coupelle broulée à crème  
Bol creme broulée

| art.     | Ø cm. | h. |
|----------|-------|----|
| 44391-12 | 11,6  | 3  |



**Egg dish, high, fluted**

Tegamino fondo, cordonato  
Schale, tief, gerippt  
Plat oeuf, creux, cannelé  
Fuente huevo borderizata, alta

| art.     | cm.   |
|----------|-------|
| 44395-18 | 18x20 |



**Soup bowl with cover**

Casseruola con coperchio  
Kasserolle mit Deckel  
Casserole avec couvercle  
Cacerola con tapa

| art.     | cm.   | lt. |
|----------|-------|-----|
| 44397-18 | 14x18 | 0,5 |



**Ramekin, fluted**

Soufflé cordonato  
Ramekin, gerippt  
Ramequin, cannelé  
Fuente soufflé borderizata

| art.     | Ø cm. | h.  |
|----------|-------|-----|
| 44390-07 | 7     | 4,0 |
| 44390-09 | 9     | 4,5 |
| 44390-11 | 11    | 6,0 |



**Ramekin, fluted**

Soufflé cordonato  
Ramekin, gerippt  
Ramequin, cannelé  
Fuente soufflé borderizata

| art.     | Ø cm. | h.  |
|----------|-------|-----|
| 44390-15 | 15    | 5,0 |
| 44390-18 | 18    | 7,5 |
| 44390-23 | 23    | 8,0 |

# GN FOOD PANS CONTENITORI GN

STAINLESS STEEL, ALUMINUM, POLYCARBONATE, POLYPROPYLENE, MELAMINE AND PORCELAIN  
INOX, ALLUMINIO, POLICARBONATO, POLIPROPILENE, MELAMINA E PORCELLANA





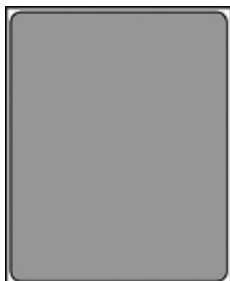

**GN-containers**

GN bacinelle  
GN-Behälter  
GN bacs  
GN cubetas



| art.     | GN  | dim. mm. | h. mm. | lt. |
|----------|-----|----------|--------|-----|
| 14101-02 | 2/1 | 650x530  | 20     | -   |
| 14101-04 | 2/1 | 650x530  | 40     | -   |
| 14101-06 | 2/1 | 650x530  | 65     | 19  |
| 14101-10 | 2/1 | 650x530  | 100    | 31  |
| 14101-15 | 2/1 | 650x530  | 150    | 46  |
| 14101-20 | 2/1 | 650x530  | 200    | 56  |



| art.     | GN  | dim. mm. | h. mm. | lt. |
|----------|-----|----------|--------|-----|
| 14102-02 | 1/1 | 530x325  | 20     | -   |
| 14102-04 | 1/1 | 530x325  | 40     | -   |
| 14102-06 | 1/1 | 530x325  | 65     | 9   |
| 14102-10 | 1/1 | 530x325  | 100    | 14  |
| 14102-15 | 1/1 | 530x325  | 150    | 21  |
| 14102-20 | 1/1 | 530x325  | 200    | 28  |



| art.     | GN  | dim. mm. | h. mm. | lt.  |
|----------|-----|----------|--------|------|
| 14103-02 | 2/3 | 353x320  | 20     | -    |
| 14103-04 | 2/3 | 353x320  | 40     | -    |
| 14103-06 | 2/3 | 353x320  | 65     | 5,5  |
| 14103-10 | 2/3 | 353x320  | 100    | 9,0  |
| 14103-15 | 2/3 | 353x320  | 150    | 13,0 |
| 14103-20 | 2/3 | 353x320  | 200    | 18,0 |



| art.     | GN  | dim. mm. | h. mm. | lt. |
|----------|-----|----------|--------|-----|
| 14104-06 | 2/4 | 162x530  | 65     | 4,0 |
| 14104-10 | 2/4 | 162x530  | 100    | 5,6 |
| 14104-15 | 2/4 | 162x530  | 150    | 8,7 |



| art.     | GN  | dim. mm. | h. mm. | lt.  |
|----------|-----|----------|--------|------|
| 14105-02 | 1/2 | 325x265  | 20     | -    |
| 14105-04 | 1/2 | 325x265  | 40     | -    |
| 14105-06 | 1/2 | 325x265  | 65     | 4,0  |
| 14105-10 | 1/2 | 325x265  | 100    | 6,5  |
| 14105-15 | 1/2 | 325x265  | 150    | 9,5  |
| 14105-20 | 1/2 | 325x265  | 200    | 12,5 |



| art.     | GN  | dim. mm. | h. mm. | lt. |
|----------|-----|----------|--------|-----|
| 14107-06 | 1/3 | 325x180  | 65     | 2,5 |
| 14107-10 | 1/3 | 325x180  | 100    | 4,0 |
| 14107-15 | 1/3 | 325x180  | 150    | 5,7 |
| 14107-20 | 1/3 | 325x180  | 200    | 7,8 |



| art.     | GN  | dim. mm. | h. mm. | lt. |
|----------|-----|----------|--------|-----|
| 14108-06 | 1/4 | 265x160  | 65     | 1,8 |
| 14108-10 | 1/4 | 265x160  | 100    | 2,8 |
| 14108-15 | 1/4 | 265x160  | 150    | 4,0 |
| 14108-20 | 1/4 | 265x160  | 200    | 5,5 |



| art.     | GN  | dim. mm. | h. mm. | lt. |
|----------|-----|----------|--------|-----|
| 14109-06 | 1/6 | 176x160  | 65     | 1,0 |
| 14109-10 | 1/6 | 176x160  | 100    | 1,6 |
| 14109-15 | 1/6 | 176x160  | 150    | 2,4 |
| 14109-20 | 1/6 | 176x160  | 200    | 3,4 |

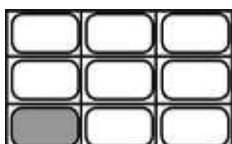

| art.     | GN  | dim. mm. | h. mm. | lt. |
|----------|-----|----------|--------|-----|
| 14110-06 | 1/9 | 176x110  | 65     | 0,6 |
| 14110-10 | 1/9 | 176x110  | 100    | 1,0 |



**GN-containers, fixed handles**

GN bacinelle, maniglie fisse

GN-Behälter mit festen Griffen

GN bacs, anses fixes

GN cubetas, asas fijas

| art.     | GN  | dim. mm. | h. mm. | lt.  |
|----------|-----|----------|--------|------|
| 14112-10 | 1/1 | 530x325  | 100    | 14,0 |
| 14112-15 | 1/1 | 530x325  | 150    | 21,0 |
| 14112-20 | 1/1 | 530x325  | 200    | 28,0 |







| art.     | GN  | dim. mm. | h. mm. | lt.  |
|----------|-----|----------|--------|------|
| 14115-10 | 1/2 | 325x265  | 100    | 6,5  |
| 14115-15 | 1/2 | 325x265  | 150    | 9,5  |
| 14115-20 | 1/2 | 325x265  | 200    | 12,5 |



| art.     | GN  | dim. mm. | h. mm. | lt. |
|----------|-----|----------|--------|-----|
| 14117-10 | 1/3 | 325x180  | 100    | 4,0 |
| 14117-15 | 1/3 | 325x180  | 150    | 5,7 |
| 14117-20 | 1/3 | 325x180  | 200    | 7,8 |

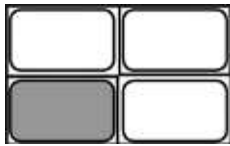

| art.     | GN  | dim. mm. | h. mm. | lt. |
|----------|-----|----------|--------|-----|
| 14118-10 | 1/4 | 265x160  | 100    | 2,8 |
| 14118-15 | 1/4 | 265x160  | 150    | 4,0 |
| 14118-20 | 1/4 | 265x160  | 200    | 5,5 |

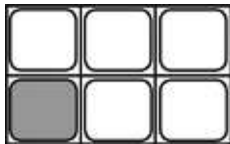

| art.     | GN  | dim. mm. | h. mm. | lt. |
|----------|-----|----------|--------|-----|
| 14119-10 | 1/6 | 176x160  | 100    | 1,6 |
| 14119-15 | 1/6 | 176x160  | 150    | 2,4 |



**GN-containers, internal handles**  
GN bacinelle, maniglie interne  
GN-Behälter mit Innen Griffen  
GN bacs, anses internes  
GN cubetas, asas internas



| art.     | GN  | dim. mm. | h. mm. | lt.  |
|----------|-----|----------|--------|------|
| 14142-10 | 1/1 | 530x325  | 100    | 14,0 |
| 14142-15 | 1/1 | 530x325  | 150    | 21,0 |
| 14142-20 | 1/1 | 530x325  | 200    | 28,0 |



| art.     | GN  | dim. mm. | h. mm. | lt.  |
|----------|-----|----------|--------|------|
| 14145-10 | 1/2 | 325x265  | 100    | 6,5  |
| 14145-15 | 1/2 | 325x265  | 150    | 9,5  |
| 14145-20 | 1/2 | 325x265  | 200    | 12,5 |



| art.     | GN  | dim. mm. | h. mm. | lt. |
|----------|-----|----------|--------|-----|
| 14147-10 | 1/3 | 325x180  | 100    | 4,0 |
| 14147-15 | 1/3 | 325x180  | 150    | 5,7 |
| 14147-20 | 1/3 | 325x180  | 200    | 7,8 |



| art.     | GN  | dim. mm. | h. mm. | lt. |
|----------|-----|----------|--------|-----|
| 14148-10 | 1/4 | 265x160  | 100    | 2,8 |
| 14148-15 | 1/4 | 265x160  | 150    | 4,0 |
| 14148-20 | 1/4 | 265x160  | 200    | 5,5 |

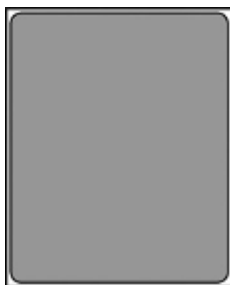

**GN-containers, falling handles**  
GN bacinelle, maniglie rientranti  
GN-Behälter mit versenkbaren Griffen  
GN bacs, anses escamotables  
GN cubetas, asas móviles



| art.     | GN  | dim. mm. | h. mm. | lt.  |
|----------|-----|----------|--------|------|
| 14151-10 | 2/1 | 650x530  | 100    | 31,0 |
| 14151-15 | 2/1 | 650x530  | 150    | 46,0 |
| 14151-20 | 2/1 | 650x530  | 200    | 56,0 |



| art.     | GN  | dim. mm. | h. mm. | lt.  |
|----------|-----|----------|--------|------|
| 14152-06 | 1/1 | 530x325  | 65     | 9,0  |
| 14152-10 | 1/1 | 530x325  | 100    | 14,0 |
| 14152-15 | 1/1 | 530x325  | 150    | 21,0 |
| 14152-20 | 1/1 | 530x325  | 200    | 28,0 |



| art.     | GN  | dim. mm. | h. mm. | lt.  |
|----------|-----|----------|--------|------|
| 14155-10 | 1/2 | 325x265  | 100    | 6,5  |
| 14155-15 | 1/2 | 325x265  | 150    | 9,5  |
| 14155-20 | 1/2 | 325x265  | 200    | 12,5 |



| art.     | GN  | dim. mm. | h. mm. | lt. |
|----------|-----|----------|--------|-----|
| 14157-10 | 1/3 | 325x180  | 100    | 4,0 |
| 14157-15 | 1/3 | 325x180  | 150    | 5,7 |
| 14157-20 | 1/3 | 325x180  | 200    | 7,8 |



| art.     | GN  | dim. mm. | h. mm. | lt. |
|----------|-----|----------|--------|-----|
| 14158-10 | 1/4 | 265x160  | 100    | 2,8 |
| 14158-15 | 1/4 | 265x160  | 150    | 4,0 |
| 14158-20 | 1/4 | 265x160  | 200    | 5,5 |

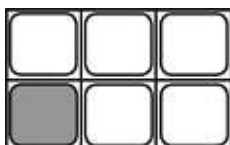

| art.     | GN  | dim. mm. | h. mm. | lt. |
|----------|-----|----------|--------|-----|
| 14159-10 | 1/6 | 176x160  | 100    | 1,6 |
| 14159-15 | 1/6 | 176x160  | 150    | 2,4 |
| 14159-20 | 1/6 | 176x160  | 200    | 3,4 |

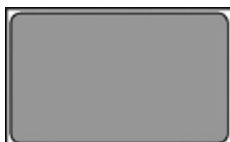

**GN-containers non stick coated**  
GN bacinelle antiaderenti  
GN-Behälter mit Antihafbeschichtung  
GN-bacs avec revêtement anti-adhésif  
GN-cubetas con cobertura antiadherente



| art.     | GN  | dim. mm. | h. mm. |
|----------|-----|----------|--------|
| 14162-02 | 1/1 | 530x325  | 20     |
| 14162-04 | 1/1 | 530x325  | 40     |
| 14162-06 | 1/1 | 530x325  | 65     |



| art.     | GN  | dim. mm. | h. mm. |
|----------|-----|----------|--------|
| 14165-02 | 1/2 | 325x265  | 20     |
| 14165-04 | 1/2 | 325x265  | 40     |
| 14165-06 | 1/2 | 325x265  | 65     |

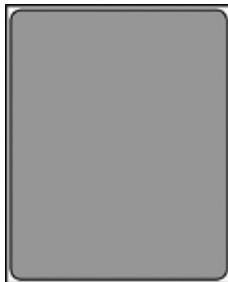

**Perforated GN-containers**

GN bacinelle forate  
Gelochte GN-Behälter  
GN bacs perforés  
GN cubetas perforados



| art.     | GN  | dim. mm. | h. mm. |
|----------|-----|----------|--------|
| 14201-02 | 2/1 | 650x530  | 20     |
| 14201-04 | 2/1 | 650x530  | 40     |
| 14201-06 | 2/1 | 650x530  | 65     |
| 14201-10 | 2/1 | 650x530  | 100    |
| 14201-15 | 2/1 | 650x530  | 150    |
| 14201-20 | 2/1 | 650x530  | 200    |

**Containers depth mm 20 and 40 only bottom perforated.** – Bacinelle profondità mm 20 e 40 forate solo sul fondo.

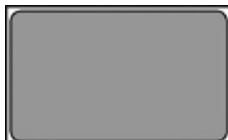

| art.     | GN  | dim. mm. | h. mm. |
|----------|-----|----------|--------|
| 14202-02 | 1/1 | 530x325  | 20     |
| 14202-04 | 1/1 | 530x325  | 40     |
| 14202-06 | 1/1 | 530x325  | 65     |
| 14202-10 | 1/1 | 530x325  | 100    |
| 14202-15 | 1/1 | 530x325  | 150    |
| 14202-20 | 1/1 | 530x325  | 200    |

**Containers depth mm 20 and 40 only bottom perforated.** – Bacinelle profondità mm 20 e 40 forate solo sul fondo.



| art.     | GN  | dim. mm. | h. mm. |
|----------|-----|----------|--------|
| 14203-06 | 2/3 | 353x320  | 65     |
| 14203-10 | 2/3 | 353x320  | 100    |
| 14203-15 | 2/3 | 353x320  | 150    |
| 14203-20 | 2/3 | 353x320  | 200    |

**Containers depth mm 20 and 40 only bottom perforated.** – Bacinelle profondità mm 20 e 40 forate solo sul fondo.



| art.     | GN  | dim. mm. | h. mm. |
|----------|-----|----------|--------|
| 14205-02 | 1/2 | 325x265  | 20     |
| 14205-04 | 1/2 | 325x265  | 40     |
| 14205-06 | 1/2 | 325x265  | 65     |
| 14205-10 | 1/2 | 325x265  | 100    |
| 14205-15 | 1/2 | 325x265  | 150    |
| 14205-20 | 1/2 | 325x265  | 200    |

**Containers depth mm 20 and 40 only bottom perforated.** – Bacinelle profondità mm 20 e 40 forate solo sul fondo.



**Perforated GN-containers, folding handles**

GN bacinelle forate, maniglie snodate  
Gelochte GN-Behälter mit Fallgriffen  
GN bacs perforés, anses pliantes  
GN cubetas perforados, asas plegables



| art.     | GN  | dim. mm. | h. mm. |
|----------|-----|----------|--------|
| 14252-06 | 1/1 | 530x325  | 65     |
| 14252-10 | 1/1 | 530x325  | 100    |
| 14252-15 | 1/1 | 530x325  | 150    |
| 14252-20 | 1/1 | 530x325  | 200    |



| art.     | GN  | dim. mm. | h. mm. |
|----------|-----|----------|--------|
| 14255-06 | 1/2 | 325x265  | 65     |
| 14255-10 | 1/2 | 325x265  | 100    |
| 14255-15 | 1/2 | 325x265  | 150    |
| 14255-20 | 1/2 | 325x265  | 200    |



**GN-lids**

GN coperchi  
GN-Deckel  
GN couvercles  
GN tapas

| art.     | GN  | dim. mm. |
|----------|-----|----------|
| 14502-00 | 1/1 | 530x325  |
| 14503-00 | 2/3 | 353x320  |
| 14504-00 | 2/4 | 162x530  |
| 14505-00 | 1/2 | 325x265  |
| 14507-00 | 1/3 | 325x180  |
| 14508-00 | 1/4 | 265x160  |
| 14509-00 | 1/6 | 176x160  |
| 14510-00 | 1/9 | 176x110  |



**GN-lids with notched edge for handles**

GN coperchi con spacco maniglie  
GN-Deckel mit Griffen-Ausschnitt  
GN couvercles avec encoche pour anses  
GN tapas con orificio asas

| art.     | GN  | dim. mm. |
|----------|-----|----------|
| 14512-00 | 1/1 | 530x325  |
| 14515-00 | 1/2 | 325x265  |
| 14517-00 | 1/3 | 325x180  |
| 14518-00 | 1/4 | 265x160  |
| 14519-00 | 1/6 | 176x160  |



**GN-lids with notched edge for ladle**

GN coperchi con spacco mestolo  
GN-Deckel mit Löffel-Ausschnitt  
GN couvercles avec encoche pour louche  
GN tapas con orificio cacillo

| art.     | GN  | dim. mm. |
|----------|-----|----------|
| 14522-00 | 1/1 | 530x325  |
| 14523-00 | 2/3 | 353x320  |
| 14525-00 | 1/2 | 325x265  |
| 14527-00 | 1/3 | 325x180  |
| 14528-00 | 1/4 | 265x160  |
| 14529-00 | 1/6 | 176x160  |



**GN-lids with notched edge for handles/ladle**

GN coperchi con spacco maniglie/mestolo  
GN-Deckel mit Griffen u. Löffel-Ausschnitt  
GN couvercles avec encoche pour anses/louche  
GN tapas con orificio asas/cacillo

| art.     | GN  | dim. mm. |
|----------|-----|----------|
| 14532-00 | 1/1 | 530x325  |
| 14535-00 | 1/2 | 325x265  |
| 14537-00 | 1/3 | 325x180  |
| 14538-00 | 1/4 | 265x160  |
| 14539-00 | 1/6 | 176x160  |



**GN-lids with silicone seal**

GN coperchi con guarnizione silicone  
GN-Deckel mit Silikondichtung  
GN couvercles avec joint silicone  
GN tapas con junta de silicona

| art.     | GN  | dim. mm. |
|----------|-----|----------|
| 14542-00 | 1/1 | 530x325  |
| 14543-00 | 2/3 | 353x320  |
| 14545-00 | 1/2 | 325x265  |
| 14547-00 | 1/3 | 325x180  |
| 14548-00 | 1/4 | 265x160  |
| 14549-00 | 1/6 | 176x160  |







**GN-lids with notched edge for handles and seal**  
GN coperchi con spacco maniglie e guarnizione  
GN-Deckel mit Griffen-Ausschnitt u. Silikondichtung  
GN couvercles avec encoche pour anses et joint  
GN tapas con orificio asas y junta

| art.     | GN  | dim. mm. |
|----------|-----|----------|
| 14552-00 | 1/1 | 530x325  |
| 14555-00 | 1/2 | 325x265  |

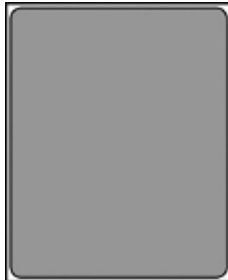

**GN-baking sheets**  
GN-teglie  
GN-Backbleche  
GN-plaques  
GN-bandejas



| art.     | GN  | dim. mm. | h. mm. |
|----------|-----|----------|--------|
| 14301-02 | 2/1 | 650x530  | 20     |
| 14301-04 | 2/1 | 650x530  | 40     |
| 14301-06 | 2/1 | 650x530  | 65     |



| art.     | GN  | dim. mm. | h. mm. |
|----------|-----|----------|--------|
| 14302-02 | 1/1 | 530x325  | 20     |
| 14302-04 | 1/1 | 530x325  | 40     |
| 14302-06 | 1/1 | 530x325  | 65     |



| art.     | GN  | dim. mm. | h. mm. |
|----------|-----|----------|--------|
| 14303-02 | 2/3 | 353x320  | 20     |
| 14303-04 | 2/3 | 353x320  | 40     |
| 14303-06 | 2/3 | 353x320  | 65     |



| art.     | GN  | dim. mm. | h. mm. |
|----------|-----|----------|--------|
| 14305-02 | 1/2 | 325x265  | 20     |
| 14305-04 | 1/2 | 325x265  | 40     |
| 14305-06 | 1/2 | 325x265  | 65     |

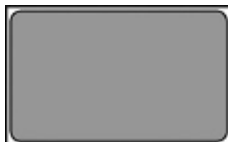

**GN-baking sheets non stick coated**  
GN-teglie con rivestimento antiaderente  
GN-Backbleche mit Antihftbeschichtung  
GN-plaques avec revêtement anti-adhésif  
GN-bandejas con cobertura antiadherente



| art.     | GN  | dim. mm. | h. mm. |
|----------|-----|----------|--------|
| 14362-02 | 1/1 | 530x325  | 20     |
| 14362-04 | 1/1 | 530x325  | 40     |
| 14362-06 | 1/1 | 530x325  | 65     |



| art.     | GN  | dim. mm. | h. mm. |
|----------|-----|----------|--------|
| 14365-02 | 1/2 | 325x265  | 20     |
| 14365-04 | 1/2 | 325x265  | 40     |
| 14365-06 | 1/2 | 325x265  | 65     |



**GN-baking sheets, ALUMINUM**

GN-teglie, ALLUMINIO  
GN-Backbleche, ALUMINIUM  
GN-plaques, ALUMINIUM  
GN-bandejas, ALUMINIO



| art.     | GN  | dim. mm. | h. mm. |
|----------|-----|----------|--------|
| 16302-02 | 1/1 | 530x325  | 20     |
| 16302-04 | 1/1 | 530x325  | 40     |
| 16302-06 | 1/1 | 530x325  | 65     |

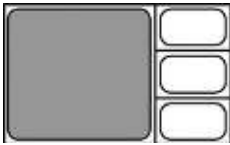

| art.     | GN  | dim. mm. | h. mm. |
|----------|-----|----------|--------|
| 16303-02 | 2/3 | 353x320  | 20     |
| 16303-04 | 2/3 | 353x320  | 40     |
| 16303-06 | 2/3 | 353x320  | 65     |



| art.     | GN  | dim. mm. | h. mm. |
|----------|-----|----------|--------|
| 16305-02 | 1/2 | 325x265  | 20     |
| 16305-04 | 1/2 | 325x265  | 40     |
| 16305-06 | 1/2 | 325x265  | 65     |



**GN-baking sheets, ALUMINUM non stick coated**

GN-teglie, ALLUMINIO antiaderente  
GN-Backbleche, ALUMINIUM mit Antihafbeschichtung  
GN-plaques, ALUMINIUM avec revêtement anti-adhésif  
GN-bandejas, ALUMINIO con cobertura antiaderente



| art.     | GN  | dim. mm. | h. mm. |
|----------|-----|----------|--------|
| 16362-02 | 1/1 | 530x325  | 20     |
| 16362-04 | 1/1 | 530x325  | 40     |
| 16362-06 | 1/1 | 530x325  | 65     |



| art.     | GN  | dim. mm. | h. mm. |
|----------|-----|----------|--------|
| 16363-02 | 2/3 | 353x320  | 20     |
| 16363-04 | 2/3 | 353x320  | 40     |
| 16363-06 | 2/3 | 353x320  | 65     |



| art.     | GN  | dim. mm. | h. mm. |
|----------|-----|----------|--------|
| 16365-02 | 1/2 | 325x265  | 20     |
| 16365-04 | 1/2 | 325x265  | 40     |
| 16365-06 | 1/2 | 325x265  | 65     |





**Drainer plate**  
Falso fondo forato  
Abtropfplatte  
Plateau double fond perforé  
Fondo perforado

| art.     | GN  |
|----------|-----|
| 14402-00 | 1/1 |
| 14405-00 | 1/2 |
| 14407-00 | 1/3 |



**Adaptor bar**  
Separatore  
StegeAdapter/Zwischensteg  
Barrette de composition  
Adaptador

| art.     | GN  | dim. mm. |
|----------|-----|----------|
| 14409-01 | 1/1 | 325      |
| 14409-02 | 2/1 | 530      |



**Pan, enamelled**  
Teglia smaltata  
Ofenblech, emalliert  
Bac émaillé  
Cubeta esmaltada

| art.     | GN  | dim. mm. | h. mm. | lt. |
|----------|-----|----------|--------|-----|
| 44322-02 | 1/1 | 530x325  | 20     | 2,5 |
| 44322-04 | 1/1 | 530x325  | 40     | 5,0 |
| 44322-06 | 1/1 | 530x325  | 65     | 9,0 |

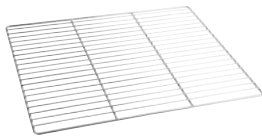

**Wire grid**  
Griglia in filo  
Gastronormrost  
Grille  
Rejilla

| art.     | GN  | dim. mm. |
|----------|-----|----------|
| 44412-00 | 1/2 | 325x265  |
| 44423-00 | 2/3 | 353x320  |
| 44421-00 | 2/1 | 650x530  |



**Wire grid with edge**  
Griglia in filo con sponda  
Gastronormrost mit Seitenwand  
Grille avec arrêt  
Rejilla con borde

| art.     | GN  | dim. mm. |
|----------|-----|----------|
| 44422-00 | 1/1 | 530x325  |

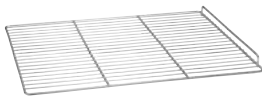

**Wire grid with edge**  
Griglia in filo con sponda  
Gastronormrost mit Seitenwand  
Grille avec arrêt  
Rejilla con borde

| art.     | GN  | dim. mm. |
|----------|-----|----------|
| 44432-21 | 2/1 | 650x530  |



**Fry basket**  
Cesta per friggere  
Frittier-Korb  
Panier à frire  
Cesta escurrefrito

| art.     | GN  | dim. mm. | h. mm. |
|----------|-----|----------|--------|
| 11750-11 | 1/1 | 530x325  | 60     |



**Grid enamelled**  
Griglia smaltata  
Rost, emalliert  
Grille émaillé  
Rejilla esmaltada

| art.     | GN  | dim. mm. |
|----------|-----|----------|
| 11760-11 | 1/1 | 530x325  |

# POLYCARBONATE POLICARBONATO

GN FOOD PANS  
CONTENITORI GN



Withstands temperatures from **-40°C to +100°C**. With metric graduation. Stackable, ideal for storage, transportation and serving display.

Termoresistenti da **-40°C a +100°C**. Con scala graduata in litri. Impilabili, sono ideali per la conservazione, trasporto ed esposizione.

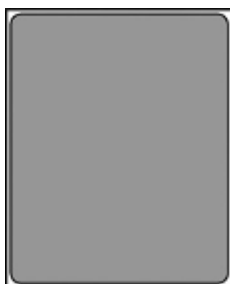

## GN-containers

GN bacinelle  
GN-Behälter  
GN bacs  
GN cubetas

| art.     | GN  | dim. mm. | h. mm. | lt. |
|----------|-----|----------|--------|-----|
| 14561-15 | 2/1 | 650x530  | 150    | 42  |
| 14561-20 | 2/1 | 650x530  | 200    | 52  |



| art.     | GN  | dim. mm. | h. mm. | lt.  |
|----------|-----|----------|--------|------|
| 14562-06 | 1/1 | 530x325  | 65     | 8,5  |
| 14562-10 | 1/1 | 530x325  | 100    | 13,0 |
| 14562-15 | 1/1 | 530x325  | 150    | 19,5 |
| 14562-20 | 1/1 | 530x325  | 200    | 26,0 |



| art.     | GN  | dim. mm. | h. mm. | lt.  |
|----------|-----|----------|--------|------|
| 14565-06 | 1/2 | 325x265  | 65     | 3,9  |
| 14565-10 | 1/2 | 325x265  | 100    | 5,9  |
| 14565-15 | 1/2 | 325x265  | 150    | 8,9  |
| 14565-20 | 1/2 | 325x265  | 200    | 11,8 |





| art.     | GN  | dim. mm. | h. mm. | lt. |
|----------|-----|----------|--------|-----|
| 14567-06 | 1/3 | 325x180  | 65     | 2,4 |
| 14567-10 | 1/3 | 325x180  | 100    | 3,6 |
| 14567-15 | 1/3 | 325x180  | 150    | 5,3 |
| 14567-20 | 1/3 | 325x180  | 200    | 7,0 |



| art.     | GN  | dim. mm. | h. mm. | lt. |
|----------|-----|----------|--------|-----|
| 14568-06 | 1/4 | 265x160  | 65     | 1,7 |
| 14568-10 | 1/4 | 265x160  | 100    | 2,5 |
| 14568-15 | 1/4 | 265x160  | 150    | 3,7 |
| 14568-20 | 1/4 | 265x160  | 200    | 5,5 |

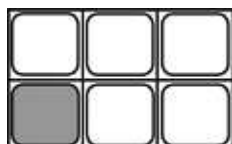

| art.     | GN  | dim. mm. | h. mm. | lt. |
|----------|-----|----------|--------|-----|
| 14569-06 | 1/6 | 176x160  | 65     | 1,0 |
| 14569-10 | 1/6 | 176x160  | 100    | 1,5 |
| 14569-15 | 1/6 | 176x160  | 150    | 2,2 |
| 14569-20 | 1/6 | 176x160  | 200    | 3,4 |



| art.     | GN  | dim. mm. | h. mm. | lt. |
|----------|-----|----------|--------|-----|
| 14570-06 | 1/9 | 176x110  | 65     | 0,6 |
| 14570-10 | 1/9 | 176x110  | 100    | 1,0 |



**GN-lid without handle**  
GN coperchio senza traversino  
GN-Deckel ohne Griff  
GN couvercle sans poignée  
GN tapa sin asa

| art.     | GN  | dim. mm. |
|----------|-----|----------|
| 14571-00 | 2/1 | 650x530  |



**GN-lids with handle**  
GN coperchi con traversino  
GN-Deckel mit Griff  
GN couvercles avec poignée  
GN tapas con asa

| art.     | GN  | dim. mm. |
|----------|-----|----------|
| 14572-00 | 1/1 | 530x325  |
| 14575-00 | 1/2 | 325x265  |
| 14577-00 | 1/3 | 325x180  |
| 14578-00 | 1/4 | 265x160  |
| 14579-00 | 1/6 | 176x160  |
| 14580-00 | 1/9 | 176x110  |



**GN-lid with silicone seal**  
GN coperchio con guarnizione silicone  
GN-Deckel mit Silikondichtung  
GN couvercle avec joint silicone  
GN tapa con junta de silicona

| art.     | GN  | dim. mm. |
|----------|-----|----------|
| 14585-00 | 1/2 | 325x265  |



**Drainer plate**  
Falso fondo forato  
Abtropfplatte  
Plateau double fond perforé  
Fondo perforado

| art.     | GN  | dim. mm. |
|----------|-----|----------|
| 14591-00 | 2/1 | 650x530  |
| 14592-00 | 1/1 | 530x325  |
| 14595-00 | 1/2 | 325x265  |
| 14597-00 | 1/3 | 325x180  |
| 14598-00 | 1/4 | 265x160  |
| 14599-00 | 1/6 | 176x160  |

# TRITAN BPA FREE

GN FOOD PANS  
CONTENITORI GN



**TRITAN - COPOLYMER - BPA FREE -40°C+90°C.**

Can be used in microwave ovens but not for prolonged times. The lids of the series 14800 polycarbonate and 14600 Tritan are interchangeable. Hermetic lids, NOT water-tight.

**TRITAN COPOLIMERO - BPA FREE -40°C+90°C.**

Utilizzabili nel microonde ma non per tempi prolungati. I coperchi della serie 14800 policarbonato e 14600 Tritan sono intercambiabili. Coperchi ermetici, NON a tenuta stagna.

## GN-containers

GN bacinelle  
GN-Behälter  
GN bacs  
GN cubetas

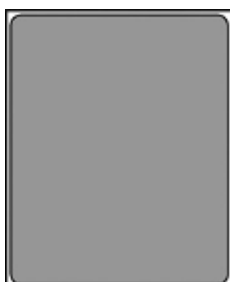

| art.     | GN  | dim. mm. | h. mm. | lt.  |
|----------|-----|----------|--------|------|
| 14661-20 | 2/1 | 650x530  | 200    | 55,5 |



| art.     | GN  | dim. mm. | h. mm. | lt.  |
|----------|-----|----------|--------|------|
| 14662-06 | 1/1 | 530x325  | 65     | 9,0  |
| 14662-10 | 1/1 | 530x325  | 100    | 13,3 |
| 14662-15 | 1/1 | 530x325  | 150    | 20,0 |
| 14662-20 | 1/1 | 530x325  | 200    | 26,4 |



| art.     | GN  | dim. mm. | h. mm. | lt.  |
|----------|-----|----------|--------|------|
| 14665-06 | 1/2 | 325x265  | 65     | 4,0  |
| 14665-10 | 1/2 | 325x265  | 100    | 6,1  |
| 14665-15 | 1/2 | 325x265  | 150    | 9,0  |
| 14665-20 | 1/2 | 325x265  | 200    | 11,9 |



| art.     | GN  | dim. mm. | h. mm. | lt. |
|----------|-----|----------|--------|-----|
| 14667-06 | 1/3 | 325x175  | 65     | 2,5 |
| 14667-10 | 1/3 | 325x175  | 100    | 3,8 |
| 14667-15 | 1/3 | 325x175  | 150    | 5,5 |
| 14667-20 | 1/3 | 325x175  | 200    | 7,1 |

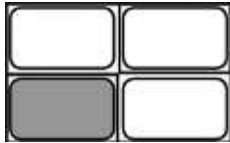

| art.     | GN  | dim. mm. | h. mm. | lt. |
|----------|-----|----------|--------|-----|
| 14668-06 | 1/4 | 264x162  | 65     | 1,7 |
| 14668-10 | 1/4 | 264x162  | 100    | 2,6 |
| 14668-15 | 1/4 | 264x162  | 150    | 3,8 |
| 14668-20 | 1/4 | 264x162  | 200    | 4,8 |



| art.     | GN  | dim. mm. | h. mm. | lt. |
|----------|-----|----------|--------|-----|
| 14669-06 | 1/6 | 176x162  | 65     | 1,0 |
| 14669-10 | 1/6 | 176x162  | 100    | 1,6 |
| 14669-15 | 1/6 | 176x162  | 150    | 2,3 |
| 14669-20 | 1/6 | 176x162  | 200    | 2,8 |



| art.     | GN  | dim. mm. | h. mm. | lt. |
|----------|-----|----------|--------|-----|
| 14670-06 | 1/9 | 176x108  | 65     | 0,6 |
| 14670-10 | 1/9 | 176x108  | 100    | 0,9 |



**GN-lids**  
GN-coperchi  
GN-Deckel  
GN couvercles  
GN tapas

| art.     | GN  | dim. mm. |
|----------|-----|----------|
| 14671-00 | 2/1 | 650x530  |
| 14672-00 | 1/1 | 530x325  |
| 14675-00 | 1/2 | 325x265  |
| 14677-00 | 1/3 | 325x175  |
| 14678-00 | 1/4 | 264x162  |
| 14679-00 | 1/6 | 176x162  |
| 14680-00 | 1/9 | 176x108  |



**GN-lids, hermetic**  
GN coperchi ermetici  
GN-Deckel, hermetisch  
GN couvercles hermétiques  
GN tapas herméticas

| art.     | GN  | dim. mm. |
|----------|-----|----------|
| 14682-00 | 1/1 | 530x325  |
| 14685-00 | 1/2 | 325x265  |
| 14687-00 | 1/3 | 325x175  |
| 14688-00 | 1/4 | 264x162  |
| 14689-00 | 1/6 | 176x162  |
| 14690-00 | 1/9 | 176x108  |



**Drainer plate**  
Falso fondo forato  
Abtropfplatte  
Plateau double fond perforé  
Fondo perforado

| art.     | GN  | dim. mm. |
|----------|-----|----------|
| 14691-00 | 2/1 | 650x530  |
| 14692-00 | 1/1 | 530x325  |
| 14695-00 | 1/2 | 325x265  |

# POLYPROPYLENE POLIPROPILENE

GN FOOD PANS  
CONTENITORI GN



Transparent and stackable. Dish-washer safe. Do not use abrasive sponges and substances. Recommended for use from  $-40^{\circ}\text{C}$  to  $+70^{\circ}\text{C}$ . Graduation scale in liters. Lids tightly fitting.

Traslucide e impilabili. Lavabili in lavastoviglie con normali detersivi. Non utilizzare pagliette e sostanze abrasive. Consigliato l'utilizzo da  $-40^{\circ}\text{C}$  a  $+70^{\circ}\text{C}$ . Scala di graduazione in litri. Coperchio resistente per una perfetta chiusura stagna.





**GN-containers**

GN bacinelle  
GN-Behälter  
GN bacs  
GN cubetas

| art.     | GN  | dim. mm. | h. mm. | lt.  |
|----------|-----|----------|--------|------|
| 14702-06 | 1/1 | 530x325  | 65     | 8,5  |
| 14702-10 | 1/1 | 530x325  | 100    | 13,0 |
| 14702-15 | 1/1 | 530x325  | 150    | 19,5 |
| 14702-20 | 1/1 | 530x325  | 200    | 26,0 |



| art.     | GN  | dim. mm. | h. mm. | lt.  |
|----------|-----|----------|--------|------|
| 14705-06 | 1/2 | 325x265  | 65     | 3,9  |
| 14705-10 | 1/2 | 325x265  | 100    | 5,9  |
| 14705-15 | 1/2 | 325x265  | 150    | 8,9  |
| 14705-20 | 1/2 | 325x265  | 200    | 11,8 |



| art.     | GN  | dim. mm. | h. mm. | lt. |
|----------|-----|----------|--------|-----|
| 14707-06 | 1/3 | 325x180  | 65     | 2,4 |
| 14707-10 | 1/3 | 325x180  | 100    | 3,6 |
| 14707-15 | 1/3 | 325x180  | 150    | 5,3 |
| 14707-20 | 1/3 | 325x180  | 200    | 7,0 |



| art.     | GN  | dim. mm. | h. mm. | lt. |
|----------|-----|----------|--------|-----|
| 14708-06 | 1/4 | 265x160  | 65     | 1,7 |
| 14708-10 | 1/4 | 265x160  | 100    | 2,5 |
| 14708-15 | 1/4 | 265x160  | 150    | 3,7 |
| 14708-20 | 1/4 | 265x160  | 200    | 5,5 |

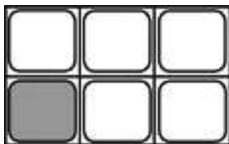

| art.     | GN  | dim. mm. | h. mm. | lt. |
|----------|-----|----------|--------|-----|
| 14709-06 | 1/6 | 176x160  | 65     | 1,0 |
| 14709-10 | 1/6 | 176x160  | 100    | 1,5 |
| 14709-15 | 1/6 | 176x160  | 150    | 2,2 |
| 14709-20 | 1/6 | 176x160  | 200    | 3,4 |



| art.     | GN  | dim. mm. | h. mm. | lt. |
|----------|-----|----------|--------|-----|
| 14710-06 | 1/9 | 176x110  | 65     | 1,3 |
| 14710-10 | 1/9 | 176x110  | 100    | 0,8 |



**Drainer plate**

Falso fondo forato  
Abtropfplatte  
Plateau double fond perforé  
Fondo perforado

| art.     | GN  | dim. mm. | h. mm. |
|----------|-----|----------|--------|
| 14712-00 | 1/1 | 471x266  | 16     |
| 14715-00 | 1/2 | 266x206  | 16     |
| 14717-00 | 1/3 | 266x117  | 16     |
| 14718-00 | 1/4 | 207x103  | 16     |
| 14719-00 | 1/6 | 117x103  | 16     |

**GN-lids**

GN-coperchi  
GN-Deckel  
GN couvercles  
GN tapas



| art.     | GN  | dim. mm. | col. |
|----------|-----|----------|------|
| 14722-00 | 1/1 | 530x325  | ●    |
| 14722-11 | 1/1 | 530x325  | ●    |
| 14722-22 | 1/1 | 530x325  | ●    |
| 14722-33 | 1/1 | 530x325  | ●    |
| 14722-99 | 1/1 | 530x325  | ○    |



| art.     | GN  | dim. mm. | col. |
|----------|-----|----------|------|
| 14725-00 | 1/2 | 325x265  | ●    |
| 14725-11 | 1/2 | 325x265  | ●    |
| 14725-22 | 1/2 | 325x265  | ●    |
| 14725-33 | 1/2 | 325x265  | ●    |
| 14725-99 | 1/2 | 325x265  | ○    |



| art.     | GN  | dim. mm. | col. |
|----------|-----|----------|------|
| 14727-00 | 1/3 | 325x180  | ●    |
| 14727-11 | 1/3 | 325x180  | ●    |
| 14727-22 | 1/3 | 325x180  | ●    |
| 14727-33 | 1/3 | 325x180  | ●    |
| 14727-99 | 1/3 | 325x180  | ○    |



| art.     | GN  | dim. mm. | col. |
|----------|-----|----------|------|
| 14728-00 | 1/4 | 265x160  | ●    |
| 14728-11 | 1/4 | 265x160  | ●    |
| 14728-22 | 1/4 | 265x160  | ●    |
| 14728-33 | 1/4 | 265x160  | ●    |
| 14728-99 | 1/4 | 265x160  | ○    |



| art.     | GN  | dim. mm. | col. |
|----------|-----|----------|------|
| 14729-00 | 1/6 | 176x160  | ●    |
| 14729-11 | 1/6 | 176x160  | ●    |
| 14729-22 | 1/6 | 176x160  | ●    |
| 14729-33 | 1/6 | 176x160  | ●    |
| 14729-99 | 1/6 | 176x160  | ○    |



| art.     | GN  | dim. mm. | col. |
|----------|-----|----------|------|
| 14730-00 | 1/9 | 176x110  | ●    |
| 14730-11 | 1/9 | 176x110  | ●    |
| 14730-22 | 1/9 | 176x110  | ●    |
| 14730-33 | 1/9 | 176x110  | ●    |
| 14730-99 | 1/9 | 176x110  | ○    |



# IML POLYPROPYLENE POLIPROPILENE IML

GN FOOD PANS  
CONTENITORI GN



With permanent in molded label. To write on the label there is a specific marker that can be removed by simply washing in the dishwasher. Withstand temperatures from  $-40^{\circ}\text{C}$  to  $+80^{\circ}\text{C}$ . With both metric and American graduated scale. **WARNING:** polypropylene containers are not suitable for use on steam tables.

Con etichetta permanente costampata. Per scrivere sull'etichetta è disponibile un pennarello specifico che viene rimosso con il semplice lavaggio in lavastoviglie. Termoresistenti da  $-40^{\circ}\text{C}$  a  $+80^{\circ}\text{C}$ . Scala graduata sia secondo sistema metrico che americano. **AVVERTENZE:** i contenitori in polipropilene non sono indicati per l'uso su tavole a vapore.

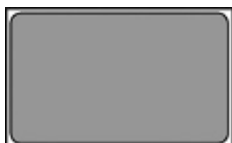

**GN-containers**

GN bacinelle  
GN-Behälter  
GN bacs  
GN cubetas

| art.     | GN  | dim. mm. | h. mm. | lt.  |
|----------|-----|----------|--------|------|
| 15101-06 | 1/1 | 530x325  | 65     | 9,0  |
| 15101-10 | 1/1 | 530x325  | 100    | 13,3 |
| 15101-15 | 1/1 | 530x325  | 150    | 20,0 |
| 15101-20 | 1/1 | 530x325  | 200    | 26,4 |



| art.     | GN  | dim. mm. | h. mm. | lt.  |
|----------|-----|----------|--------|------|
| 15105-06 | 1/2 | 325x265  | 65     | 4,0  |
| 15105-10 | 1/2 | 325x265  | 100    | 6,1  |
| 15105-15 | 1/2 | 325x265  | 150    | 9,0  |
| 15105-20 | 1/2 | 325x265  | 200    | 11,9 |

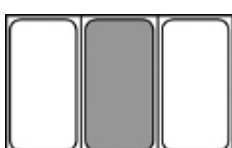

| art.     | GN  | dim. mm. | h. mm. | lt. |
|----------|-----|----------|--------|-----|
| 15107-06 | 1/3 | 325x175  | 65     | 2,5 |
| 15107-10 | 1/3 | 325x175  | 100    | 3,8 |
| 15107-15 | 1/3 | 325x175  | 150    | 5,5 |
| 15107-20 | 1/3 | 325x175  | 200    | 7,1 |



| art.     | GN  | dim. mm. | h. mm. | lt. |
|----------|-----|----------|--------|-----|
| 15108-06 | 1/4 | 264x162  | 65     | 1,7 |
| 15108-10 | 1/4 | 264x162  | 100    | 2,6 |
| 15108-15 | 1/4 | 264x162  | 150    | 3,8 |
| 15108-20 | 1/4 | 264x162  | 200    | 4,8 |

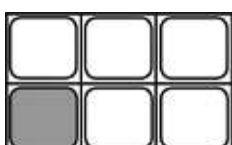

| art.     | GN  | dim. mm. | h. mm. | lt. |
|----------|-----|----------|--------|-----|
| 15109-06 | 1/6 | 176x162  | 65     | 1,0 |
| 15109-10 | 1/6 | 176x162  | 100    | 1,6 |
| 15109-15 | 1/6 | 176x162  | 150    | 2,3 |
| 15109-20 | 1/6 | 176x162  | 200    | 2,8 |

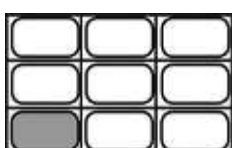

| art.     | GN  | dim. mm. | h. mm. | lt. |
|----------|-----|----------|--------|-----|
| 15110-06 | 1/9 | 176x108  | 65     | 0,6 |
| 15110-10 | 1/9 | 176x108  | 100    | 0,9 |



**Drainer plate**

Falso fondo forato  
Abtropfplatte  
Plateau double fond perforé  
Fondo perforado

| art.     | GN  | dim. mm. |
|----------|-----|----------|
| 14912-00 | 1/1 | 530x325  |
| 14915-00 | 1/2 | 325x265  |



**GN hermetic lids with overmolded GASKET**

Coperchi GN ermetici con GUARNIZIONE sovrastampata  
GN hermetische Deckel mit umspritzter DICHTUNG  
Couvercles GN hermétiques avec JOINT surmoulé  
Tapas GN herméticas con JUNTA sobremoldeada

| art.     | GN  | dim. mm. |
|----------|-----|----------|
| 14942-99 | 1/1 | 530x325  |
| 14945-99 | 1/2 | 325x265  |
| 14947-99 | 1/3 | 325x175  |





**GN-lids**  
GN coperchi  
GN-Deckel  
GN couvercles  
GN tapas

| art.     | GN  | dim. mm. | col. |
|----------|-----|----------|------|
| 14922-00 | 1/1 | 530x325  | ●    |
| 14922-11 | 1/1 | 530x325  | ●    |
| 14922-22 | 1/1 | 530x325  | ●    |
| 14922-33 | 1/1 | 530x325  | ●    |
| 14922-77 | 1/1 | 530x325  | ●    |
| 14922-99 | 1/1 | 530x325  | ○    |



| art.     | GN  | dim. mm. | col. |
|----------|-----|----------|------|
| 14925-00 | 1/2 | 325x265  | ●    |
| 14925-11 | 1/2 | 325x265  | ●    |
| 14925-22 | 1/2 | 325x265  | ●    |
| 14925-33 | 1/2 | 325x265  | ●    |
| 14925-77 | 1/2 | 325x265  | ●    |
| 14925-99 | 1/2 | 325x265  | ○    |



| art.     | GN  | dim. mm. | col. |
|----------|-----|----------|------|
| 14927-00 | 1/3 | 325x175  | ●    |
| 14927-11 | 1/3 | 325x175  | ●    |
| 14927-22 | 1/3 | 325x175  | ●    |
| 14927-33 | 1/3 | 325x175  | ●    |
| 14927-77 | 1/3 | 325x175  | ●    |
| 14927-99 | 1/3 | 325x175  | ○    |



| art.     | GN  | dim. mm. | col. |
|----------|-----|----------|------|
| 14928-00 | 1/4 | 264x162  | ●    |
| 14928-11 | 1/4 | 264x162  | ●    |
| 14928-22 | 1/4 | 264x162  | ●    |
| 14928-33 | 1/4 | 264x162  | ●    |
| 14928-77 | 1/4 | 264x162  | ●    |
| 14928-99 | 1/4 | 264x162  | ○    |



| art.     | GN  | dim. mm. | col. |
|----------|-----|----------|------|
| 14929-00 | 1/6 | 176x162  | ●    |
| 14929-11 | 1/6 | 176x162  | ●    |
| 14929-22 | 1/6 | 176x162  | ●    |
| 14929-33 | 1/6 | 176x162  | ●    |
| 14929-77 | 1/6 | 176x162  | ●    |
| 14929-99 | 1/6 | 176x162  | ○    |



| art.     | GN  | dim. mm. | col. |
|----------|-----|----------|------|
| 14930-00 | 1/9 | 176x108  | ●    |
| 14930-11 | 1/9 | 176x108  | ●    |
| 14930-22 | 1/9 | 176x108  | ●    |
| 14930-33 | 1/9 | 176x108  | ●    |
| 14930-77 | 1/9 | 176x108  | ●    |
| 14930-99 | 1/9 | 176x108  | ○    |



**Clips for lids**  
 Clips per coperchi  
 Clips für Deckel  
 Clips pour couvercles  
 Clips para tapas

| art.     | U. Pack | col. |
|----------|---------|------|
| 15100-01 | 12      | ●    |
| 15100-02 | 12      | ●    |
| 15100-03 | 12      | ●    |
| 15100-04 | 12      | ●    |
| 15100-07 | 12      | ●    |



**Kit 2 markers**  
 Set 2 pennarelli  
 Satz 2 Marker  
 Set 2 marqueurs  
 Juego 2 marcadores

art.  
 15100-AA





Melamine is suitable for hot and cold food use. Melamine is suitable for food storage at ambient or chilled temperatures for up to 24 hours. Melamine is not suitable for hot counters, displays, or heated cabinets. Do not expose melamine to direct flame or heat, including heat lamps and plate warmers. Temperature rating is between -20°C and 70°C (-4°F +158°F).

La melamina è adatta per l'uso sia con cibi caldi che freddi. La melamina è adatta per la conservazione degli alimenti a temperatura ambiente o refrigerata fino a 24 ore. La melamina non è adatta per piani caldi, espositori o armadi riscaldati. Non esporre a calore e fiamme dirette, incluse lampade alogene e scaldapiatti. Non esporre gli oggetti in melamina a temperature superiori a 70°C (-20°C +70°C).

GN-containers / Bacinelle / Behälter / Bacs / Cubetas



| art.     | GN  | dim. mm. | h. mm. | lt.  | col. |
|----------|-----|----------|--------|------|------|
| 44877-11 | 1/1 | 530X325  | 65     | 7,1  | ○    |
| 44877B11 | 1/1 | 530X325  | 100    | 10,6 | ○    |
| 44878-11 | 1/1 | 530X325  | 65     | 7,1  | ●    |
| 44878B11 | 1/1 | 530X325  | 100    | 10,6 | ●    |



| art.     | GN  | dim. mm. | h. mm. | lt. | col. |
|----------|-----|----------|--------|-----|------|
| 44877-24 | 2/4 | 160x530  | 65     | 3,0 | ○    |
| 44877B24 | 2/4 | 160x530  | 100    | 4,3 | ○    |
| 44878-24 | 2/4 | 160x530  | 65     | 3,0 | ●    |
| 44878B24 | 2/4 | 160x530  | 100    | 4,3 | ●    |



| art.     | GN  | dim. mm. | h. mm. | lt. | col. |
|----------|-----|----------|--------|-----|------|
| 44877-12 | 1/2 | 325X265  | 65     | 3,4 | ○    |
| 44877B12 | 1/2 | 325X265  | 100    | 4,7 | ○    |
| 44878-12 | 1/2 | 325X265  | 65     | 3,4 | ●    |
| 44878B12 | 1/2 | 325X265  | 100    | 4,7 | ●    |



| art.     | GN  | dim. mm. | h. mm. | lt. | col. |
|----------|-----|----------|--------|-----|------|
| 44877-13 | 1/3 | 325X175  | 65     | 2,0 | ○    |
| 44877B13 | 1/3 | 325X175  | 100    | 2,7 | ○    |
| 44878-13 | 1/3 | 325X175  | 65     | 2,0 | ●    |
| 44878B13 | 1/3 | 325X175  | 100    | 2,7 | ●    |

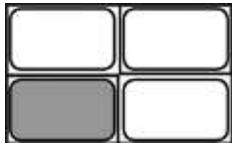

| art.     | GN  | dim. mm. | h. mm. | lt. | col. |
|----------|-----|----------|--------|-----|------|
| 44877-14 | 1/4 | 265X160  | 65     | 1,4 | ○    |
| 44877B14 | 1/4 | 265X160  | 100    | 1,9 | ○    |
| 44878-14 | 1/4 | 265X160  | 65     | 1,4 | ●    |
| 44878B14 | 1/4 | 265X160  | 100    | 1,9 | ●    |



| art.     | GN  | dim. mm. | h. mm. | lt. | col. |
|----------|-----|----------|--------|-----|------|
| 44877-16 | 1/6 | 175X160  | 65     | 0,8 | ○    |
| 44877B16 | 1/6 | 175X160  | 100    | 1,0 | ○    |
| 44878-16 | 1/6 | 175X160  | 65     | 0,8 | ●    |
| 44878B16 | 1/6 | 175X160  | 100    | 1,0 | ●    |



**GN-lids, POLICARBONATE**  
GN-coperchi, POLICARBONATO  
GN-Deckel, POLIKARBONAT  
GN couvercles, POLICARBONATE  
GN tapas, POLICARBONATO

| art.     | GN  | dim. mm. |
|----------|-----|----------|
| 44818-11 | 1/1 | 530X325  |
| 44818-12 | 1/2 | 325X265  |
| 44818-13 | 1/3 | 325X175  |
| 44818-14 | 1/4 | 265X160  |
| 44818-16 | 1/6 | 175X160  |

PC



**Buffet ladder, chrome plated**  
Espositore buffet, cromato  
Büffet-Leiter, verchromt  
Escalier à buffet, chromé  
Escalera para buffet, cromada

| art.     | GN  | dim. mm.     |
|----------|-----|--------------|
| 41403-01 | 1/3 | 31,5x32x48   |
| 41403-02 | 1/2 | 31,5x41,5x48 |
| 41403-03 | 1/2 | 31,5x56x66   |
| 41403-04 | 1/1 | 52x59x66     |

GN





# PORCELAIN PORCELLANA

GN FOOD PANS  
CONTENITORI GN



## GN-containers

GN bacinelle  
GN-Behälter  
GN bacs  
GN cubetas

| art.     | GN  | dim. mm. | h. mm. | col. |
|----------|-----|----------|--------|------|
| 44332-03 | 1/1 | 530x325  | 20     | ○    |
| 44332-06 | 1/1 | 530x325  | 65     | ○    |
| 44382A06 | 1/1 | 530x325  | 65     | ●    |
| 44382B06 | 1/1 | 530x325  | 65     | ●    |
| 44382G06 | 1/1 | 530x325  | 65     | ●    |
| 44382O06 | 1/1 | 530x325  | 65     | ●    |
| 44382Y06 | 1/1 | 530x325  | 65     | ●    |
| 44332B06 | 1/1 | 530x325  | 65     | ●    |



| art.     | GN  | dim. mm. | h. mm. | col. |
|----------|-----|----------|--------|------|
| 44333-03 | 2/3 | 353x320  | 20     | ○    |
| 44333-06 | 2/3 | 353x320  | 65     | ○    |
| 44333B06 | 2/3 | 353x320  | 65     | ●    |
| 44383O06 | 2/3 | 353x320  | 65     | ●    |
| 44383Y06 | 2/3 | 353x320  | 65     | ●    |

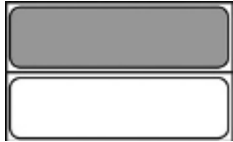

| art.     | GN  | dim. mm. | h. mm. | col. |
|----------|-----|----------|--------|------|
| 44334-03 | 2/4 | 162x530  | 20     | ○    |
| 44334-06 | 2/4 | 162x530  | 65     | ○    |
| 44384A06 | 2/4 | 162x530  | 65     | ●    |
| 44384O06 | 2/4 | 162x530  | 65     | ●    |
| 44384R06 | 2/4 | 162x530  | 65     | ●    |
| 44384Y06 | 2/4 | 162x530  | 65     | ●    |



| art.     | GN  | dim. mm. | h. mm. | col. |
|----------|-----|----------|--------|------|
| 44335-03 | 1/2 | 325x265  | 20     | ○    |
| 44335-06 | 1/2 | 325x265  | 65     | ○    |
| 44335B06 | 1/2 | 325x265  | 65     | ●    |
| 44385A06 | 1/2 | 325x265  | 65     | ●    |
| 44385B06 | 1/2 | 325x265  | 65     | ●    |
| 44385G06 | 1/2 | 325x265  | 65     | ●    |
| 44385O06 | 1/2 | 325x265  | 65     | ●    |
| 44385R06 | 1/2 | 325x265  | 65     | ●    |
| 44385Y06 | 1/2 | 325x265  | 65     | ●    |



| art.     | GN  | dim. mm. | h. mm. | col. |
|----------|-----|----------|--------|------|
| 44337-03 | 1/3 | 325x175  | 20     | ○    |
| 44337-06 | 1/3 | 325x175  | 65     | ○    |
| 44337B06 | 1/3 | 325x175  | 65     | ●    |
| 44387A06 | 1/3 | 325x175  | 65     | ●    |
| 44387B06 | 1/3 | 325x175  | 65     | ●    |
| 44387G06 | 1/3 | 325x175  | 65     | ●    |
| 44387O06 | 1/3 | 325x175  | 65     | ●    |
| 44387R06 | 1/3 | 325x175  | 65     | ●    |
| 44387Y06 | 1/3 | 325x175  | 65     | ●    |



| art.     | GN  | dim. mm. | h. mm. | col. |
|----------|-----|----------|--------|------|
| 44338-03 | 1/4 | 265x160  | 20     | ○    |
| 44338-06 | 1/4 | 265x160  | 65     | ○    |

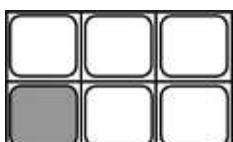

| art.     | GN  | dim. mm. | h. mm. | col. |
|----------|-----|----------|--------|------|
| 44339-03 | 1/6 | 176x160  | 20     | ○    |
| 44339-06 | 1/6 | 176x160  | 65     | ○    |



# INDUCTION PORCELAIN PORCELLANA INDUZIONE

GN FOOD PANS  
CONTENITORI GN

PR GN  INDUCTION  
READY!



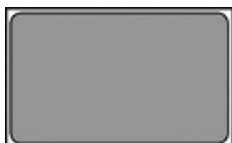

**GN-containers**

GN bacinelle

GN-Behälter

GN bacs

GN cubetas

| art.     | GN  | dim. mm. | h. mm. | col. |
|----------|-----|----------|--------|------|
| 44342-06 | 1/1 | 530x325  | 65     | ○    |
| 44312A06 | 1/1 | 530x325  | 65     | ●    |
| 44312B06 | 1/1 | 530x325  | 65     | ●    |
| 44312G06 | 1/1 | 530x325  | 65     | ●    |
| 44312O06 | 1/1 | 530x325  | 65     | ●    |
| 44312R06 | 1/1 | 530x325  | 65     | ●    |
| 44312Y06 | 1/1 | 530x325  | 65     | ●    |



| art.     | GN  | dim. mm. | h. mm. | col. |
|----------|-----|----------|--------|------|
| 44343-06 | 2/3 | 353x320  | 65     | ○    |
| 44313B06 | 2/3 | 353x320  | 65     | ●    |
| 44313G06 | 2/3 | 353x320  | 65     | ●    |
| 44313O06 | 2/3 | 353x320  | 65     | ●    |
| 44313R06 | 2/3 | 353x320  | 65     | ●    |
| 44313Y06 | 2/3 | 353x320  | 65     | ●    |



| art.     | GN  | dim. mm. | h. mm. | col. |
|----------|-----|----------|--------|------|
| 44344-06 | 2/4 | 162x530  | 65     | ○    |
| 44314A06 | 2/4 | 162x530  | 65     | ●    |
| 44314B06 | 2/4 | 162x530  | 65     | ●    |
| 44314G06 | 2/4 | 162x530  | 65     | ●    |
| 44314O06 | 2/4 | 162x530  | 65     | ●    |
| 44314R06 | 2/4 | 162x530  | 65     | ●    |
| 44314Y06 | 2/4 | 162x530  | 65     | ●    |



| art.     | GN  | dim. mm. | h. mm. | col. |
|----------|-----|----------|--------|------|
| 44345-06 | 1/2 | 325x265  | 65     | ○    |
| 44315A06 | 1/2 | 325x265  | 65     | ●    |
| 44315B06 | 1/2 | 325x265  | 65     | ●    |
| 44315G06 | 1/2 | 325x265  | 65     | ●    |
| 44315O06 | 1/2 | 325x265  | 65     | ●    |
| 44315R06 | 1/2 | 325x265  | 65     | ●    |
| 44315Y06 | 1/2 | 325x265  | 65     | ●    |



| art.     | GN  | dim. mm. | h. mm. | col. |
|----------|-----|----------|--------|------|
| 44347-06 | 1/3 | 325x175  | 65     | ○    |
| 44317A06 | 1/3 | 325x175  | 65     | ●    |
| 44317B06 | 1/3 | 325x175  | 65     | ●    |
| 44317G06 | 1/3 | 325x175  | 65     | ●    |
| 44317O06 | 1/3 | 325x175  | 65     | ●    |
| 44317R06 | 1/3 | 325x175  | 65     | ●    |
| 44317Y06 | 1/3 | 325x175  | 65     | ●    |



| art.     | GN  | dim. mm. | h. mm. | col. |
|----------|-----|----------|--------|------|
| 44346-06 | 1/4 | 265x160  | 65     | ○    |





# SERIES 12900

KITCHEN UTENSILS  
UTENSILI DA CUCINA

PA+  
plus



A wide range of professional kitchen utensils in composite material, polyamide (nylon 6.6) with fiberglass. Dishwasher safe, can be sterilized, heat resistant up to 220°C. Safe for non-stick cookware.

Un'ampia gamma di utensili professionali per la cucina in materiale composito, poliammide (nylon 6.6) con fibra di vetro. Lavabili in lavastoviglie, sterilizzabili, resistenti fino a 220°C. Ideali per l'uso con antiaderenti.



**PA+**  
plus

**Spoon**  
Cucchiaione  
Löffel  
Mouvette  
Cuchara

| art.     | l. cm. |
|----------|--------|
| 12903-30 | 30     |
| 12903-40 | 38     |
| 12903-45 | 45     |



**PA+**  
plus

**Spatula**  
Spatola  
Teigschäber  
Spatule  
Espátula

| art.     | l. cm. |
|----------|--------|
| 12905-25 | 25     |
| 12905-30 | 30     |
| 12905-35 | 35     |
| 12905-40 | 40     |
| 12905-45 | 45     |
| 12905-50 | 50     |



**PA+**  
plus

**Stirring ladle**  
Spatola per stemperare  
Rühr-u. Temperierlöffel  
Spatule à délayer  
Espátula para diluir

| art.     | l. cm. |
|----------|--------|
| 12907-07 | 35     |
| 12907-08 | 35     |



**PA+**  
plus

**Spatula**  
Spatola  
Stielschäber  
Spatule  
Espátula

| art.     | l. cm. |
|----------|--------|
| 12915-25 | 25     |
| 12915-26 | 28     |
| 12915-35 | 35     |
| 12915-45 | 45     |



**PA+**  
plus

**Spatula**  
Spatola  
Teigschäber  
Spatule  
Espátula

| art.     | l. cm. |
|----------|--------|
| 12916-25 | 25     |
| 12916-33 | 33     |



**PA+**  
plus

**Spatula**  
Spatola triangolare  
Dreieck-Stielschäber  
Spatule trilon  
Espátula triangular

| art.     | l. cm. |
|----------|--------|
| 12917-25 | 25     |



**PA+**  
plus

**Bevelled spatula**  
Spatola smussata  
Teigschäber  
Spatule plate biseautée  
Espátula blanda

| art.     | l. cm. |
|----------|--------|
| 12906-35 | 35     |



**PA+**  
plus

**Spatula**  
Spatola  
Teigschäber  
Spatule  
Espátula

| art.     | l. cm. |
|----------|--------|
| 12908-30 | 30     |
| 12908-35 | 35     |
| 12908-40 | 40     |



**PA+**  
plus

**Angular spatula**  
Paletta angolare  
Winkelpalette  
Spatule angulaire  
Espátula

| art.     | l. cm. |
|----------|--------|
| 12909-12 | 12     |
| 12909-23 | 23     |



**PA+**  
plus

**Spatula, perforated**  
Paletta forata  
Teigschäber, perforiert  
Spatule ajourée  
Espátula perforada

| art.     | l. cm. |
|----------|--------|
| 12921-01 | 30     |



**PA+**  
plus

**Spatula, perforated**  
Paletta forata  
Teigschäber, perforiert  
Spatule ajourée  
Espátula perforada

| art.     | l. cm. |
|----------|--------|
| 12921-05 | 30     |



**PA+**  
plus

**Spatula**  
Paletta  
Teigschäber  
Spatule  
Espátula

| art.     | l. cm. |
|----------|--------|
| 12921-10 | 32     |



**PA+**  
*plus*

**Fish & chips spatula**

Paletta fritti  
Fischheber  
Pelle à friture  
Espátula fritura

| art.     | l. cm. |
|----------|--------|
| 12921-15 | 35     |



**PA+**  
*plus*

**Ladle**

Mestolo  
Schöpfplößel  
Louche  
Cacillo

| art.     | Ø cm. | l. cm. |
|----------|-------|--------|
| 12920-01 | 9     | 31     |



**PA+**  
*plus*

**Skimmer**

Schiumarola  
Schaumlößel  
Ecumoire  
Espumadera

| art.     | Ø cm. | l. cm. |
|----------|-------|--------|
| 12920-05 | 11    | 35     |



**PA+**  
*plus*

**Spatula**

Paletta  
Teigschäber  
Spatule  
Espátula

| art.     | cm.  | l. cm. |
|----------|------|--------|
| 12920-10 | 9x10 | 35     |



**PA+**  
*plus*

**Fish & chips spatula**

Paletta fritti  
Fischheber  
Pelle à friture  
Espátula fritura

| art.     | cm.  | l. cm. |
|----------|------|--------|
| 12920-11 | 9x10 | 35     |



**PA+**  
*plus*

**Spoon**

Cucchiaione  
Giesslöffel  
Cuillère  
Cucharón

| art.     | l. cm. |
|----------|--------|
| 12920-15 | 35     |



**PA+**  
*plus*

**Perforated spoon**

Cucchiaione forato  
Giesslöffel, perforiert  
Cuillère perforée  
Cucharón perforado

| art.     | l. cm. |
|----------|--------|
| 12920-16 | 35     |



**PA+**  
*plus*

**Salad tongs**

Molla insalata  
Salatzange  
Pince à salade  
Pinza ensalada

| art.     | l. cm. |
|----------|--------|
| 12930-51 | 25     |
| 12930-52 | 32     |



**PA+**  
*plus*

**Bread and pastry tongs**

Molla per pane e pasticceria  
Brot-/Gebäckzange  
Pince à pain et pâtisserie  
Pinza para pan y pasteleria

| art.     | l. cm. |
|----------|--------|
| 12930-62 | 18     |
| 12930-63 | 23     |



**PA+**  
*plus*

**Serving tongs**

Molla tutto servire  
Servierzange  
Pince à servir  
Pinza servir

| art.     | l. cm. |
|----------|--------|
| 12930-68 | 20     |
| 12930-69 | 25     |



**PA+**  
*plus*

**Spaghetti tongs**

Molla spaghetti  
Spaghettizange  
Pince à spaghetti  
Pinza espagueti

| art.     | l. cm. |
|----------|--------|
| 12930-74 | 24     |



**PA+**  
*plus*

**Toast and pastry tongs**

Molla per toast e dolci  
Toast-/Gebäckzange  
Pince à toast et tarte  
Pinza para tostadas y dulces

| art.     | l. cm. |
|----------|--------|
| 12930-77 | 21     |
| 12930-78 | 25     |



PA+  
plus

**Meat ball plier**  
Forbice per polpette  
Fleischkugelzange  
Pince à boulettes  
Pinza albóndigas

| art.     | l. cm. |
|----------|--------|
| 12931-51 | 17     |



PA+  
plus

**Quenelle plier**  
Forbice per chenelle  
Quenellezange  
Pince à quenelles  
Pinza quenelles

| art.     | l. cm. |
|----------|--------|
| 12931-53 | 19     |



PA+  
plus

**Perforated ladle**  
Mestolo forato  
Schöpföffel, gelocht  
Louche perforée  
Cacillo perforado

| art.     | Ø cm. | l. cm. |
|----------|-------|--------|
| 12967-06 | 6,5   | 30     |
| 12967-10 | 10,0  | 37,5   |



PA+  
plus

**Ladle**  
Mestolo  
Schöpföffel  
Louche  
Cacillo

| art.      | Ø cm. | l. cm. |
|-----------|-------|--------|
| 12970-06* | 6,5   | 30,0   |
| 12970-08  | 8,0   | 33,5   |
| 12970-10  | 10,0  | 37,5   |
| 12970-12  | 12,0  | 40,0   |

\*With spout. – Con becco.



PA+  
plus

**Pizza ladle, flat bottom**  
Mestolo pizza, fondo piatto  
Schöpföffel  
Louche  
Cacillo

| art.     | Ø cm. | l. cm. |
|----------|-------|--------|
| 12968-10 | 10    | 27     |



PA+  
plus

**Ladle, short handle**  
Mestolo, manico corto  
Schöpföffel mit kurzen Stiel  
Louche, manche court  
Cacillo, mango corto

| art.     | Ø cm. | l. cm. |
|----------|-------|--------|
| 12969-10 | 10    | 27     |



PA+  
plus

**Ladle, short handle**  
Mestolo, manico corto  
Schöpföffel mit kurzen Stiel  
Louche, manche court  
Cacillo, mango corto

| art.     | Ø cm. | l. cm. |
|----------|-------|--------|
| 12969-06 | 6,5   | 24     |



PA+  
plus

**Spoon**  
Cucchiaione  
Löffel  
Cuillère  
Cuchara

| art.     | l. cm. |
|----------|--------|
| 12986-38 | 37,5   |



PA+  
plus

**Spoon, short handle**  
Cucchiaione, manico corto  
Löffel mit kurzen Stiel  
Cuillère, manche court  
Cuchara, mango corto

| art.     | l. cm. |
|----------|--------|
| 12986-01 | 23     |



PA+  
plus

**Skimmer**  
Schiumarola  
Schaumlöffel  
Ecumoire  
Espumadera

| art.     | Ø cm. | l. cm. |
|----------|-------|--------|
| 12971-10 | 10    | 31     |
| 12971-12 | 12    | 37     |



PA+  
plus

**Spatula**  
Paletta liscia  
Backschaufel  
Spatule  
Espátula lisa

| art.     | cm. | l. cm. |
|----------|-----|--------|
| 12972-10 | 10  | 36,5   |
| 12972-12 | 12  | 38,0   |



PA+  
plus

**Perforated spatula**  
Paletta forata  
Backschaufel, perforiert  
Spatule perforée  
Espátula perforada

| art.     | cm. | l. cm. |
|----------|-----|--------|
| 12973-10 | 10  | 36,5   |
| 12973-12 | 12  | 38     |





PA+  
plus

**Conical colander**

Colatutto tronco conico  
Gemüsesieher  
Passoire à légumes  
Colador cónico

| art.     | Ø cm. | h. | lt. |
|----------|-------|----|-----|
| 12950-32 | 32    | 16 | 8   |
| 12950-40 | 40    | 20 | 12  |



SS  
PA+  
plus

**Strainer**

Colatutto  
Sieb  
Passoire  
Colador multiuso

| art.     | cm.     | l. cm. |
|----------|---------|--------|
| 12932-22 | 22x18,5 | 44     |
| 12932-26 | 26x21   | 47     |



SS  
PA+  
plus

**Soup strainer**

Colino a rete  
Suppensieb  
Passe-bouillon  
Colador a red

| art.     | Ø cm. | l. cm. |
|----------|-------|--------|
| 12941-07 | 7     | 12     |
| 12941-10 | 10    | 12     |
| 12941-12 | 12    | 17     |
| 12941-14 | 14    | 17     |
| 12941-16 | 16    | 17     |
| 12941-18 | 18    | 17     |
| 12941-23 | 23    | 27     |
| 12941-26 | 26    | 27     |



SS  
PA+  
plus

**Wire whip, 8 silicone wires**

Frusta, 8 fili silicone  
Rührbesen, 8 Drähte aus Silikon  
Fouet, 8 fils en silicone  
Batidor, 8 varillas de siliconea

| art.     | l. cm. |
|----------|--------|
| 12926-35 | 35     |



SS  
PA+  
plus

**Wire whip, 8 wires**

Frusta, 8 fili  
Rührbesen, 8 Drähte  
Fouet, 8 fils  
Batidor, 8 varillas

| art.     | l. cm. |
|----------|--------|
| 12928-25 | 25     |
| 12928-30 | 30     |
| 12928-35 | 35     |
| 12928-40 | 40     |
| 12928-45 | 45     |
| 12928-50 | 50     |
| 12928-55 | 55     |
| 12928-60 | 60     |



SS  
PA+  
plus

**Egg whisk, 11 wires**

Frusta media, 11 fili  
Schneebeesen, 11 Drähte  
Fouet, 11 fils  
Batidor, 11 varillas

| art.     | l. cm. |
|----------|--------|
| 12929-25 | 25     |
| 12929-30 | 30     |
| 12929-35 | 35     |
| 12929-40 | 40     |
| 12929-45 | 45     |



SS  
PA+  
plus

**Balloon whisk**

Frusta balloon  
Schneebeesen  
Fouet à blancs  
Batidor tipo globo

| art.     | l. cm. |
|----------|--------|
| 12927-35 | 35     |
| 12927-45 | 45     |

**Water-tight, dishwasher safe.** – Perfetta tenuta stagna, lavabile in lavastoviglie.

**Water-tight, dishwasher safe.** – Perfetta tenuta stagna, lavabile in lavastoviglie.

# SERIES 48280 - 48278

KITCHEN UTENSILS  
UTENSILI DA CUCINA



**A wide range of professional kitchen utensils. These are essential tools to make original decorations as well as to ease the preparation of your recipes. All items are made of 18/10 stainless steel while their ergonomic handles are available both in stainless steel and Polypropylene. They are all hangable and can be cleaned in dishwasher. They boast a modern, functional design and are very easy to use.**

Un'ampia gamma di utensili professionali per la cucina, indispensabili per creare decorazioni originali e fantasiose, ma utili anche per svolgere le più semplici operazioni in modo preciso e veloce. Tutti i pezzi sono realizzati in acciaio inox 18/10, mentre la manichatura ergonomica è prevista nella versione acciaio inox o polipropilene. Tutti gli articoli sono dotati di un foro sul manico per essere appesi. Lavabili in lavastoviglie. Il design è moderno e funzionale per il massimo comfort d'utilizzo.



**Pizza chef knife**

Coltello pizzaiolo  
Messer für Pizzakoch  
Couteau à chef de pizza  
Cuchillo para chef de pizza

art. l. cm.  
48280-45 23,5



**Pizza wheel**

Rotella tagliapizza  
Pizzaschneider  
Roulette à pizza  
Ruedecilla cortapizzas

art. Ø cm. l. cm.  
18324-10 10 24



**Pastry wheel**

Rotella tagliapasta  
Teigrädchen  
Roulette à pâte  
Ruedecilla para pasta

art. Ø cm. l. cm.  
48280-32 4 18



**Double pastry wheel**

Rotella tagliapasta doppia  
Doppel-Teigrädchen  
Roulette à pâte double  
Ruedecilla para pasta doble

art. Ø cm. l. cm.  
48280-39 4 18



**Vegetable knife**

Coltello verdure  
Gemüsemesser  
Couteau à légumes  
Cuchillo para verduras

art. l. cm.  
48280-48 19



**One-hand mincing knife**

Falcetta prezzemolo  
Einhandwiegemesser  
Hachinette persil  
Cuchillo para perejil

art. Ø cm. l. cm.  
48280-20 11 17



**Parmesan cheese knife**

Coltello grana  
Parmesanmesser  
Couteau à Parmesan  
Cuchillo queso parmeso

art. l. cm.  
48280-04 20



**Oyster knife**

Coltello apriostriche  
Austernmesser  
Couteau à huîtres  
Cuchillo ostras

art. l. cm.  
48280-05 20,5



**Chestnut knife**

Coltello castagne  
Kastanienmesser  
Couteau à châtaignes  
Cuchillo castañas

art. l. cm.  
48280-21 16



**Fish scaler**

Squamapesce  
Fischentschupper  
Ecailleur  
Raspador de escamas

art. l. cm.  
48280-38 23,5





**Double fish scaler**

Squamapesce doppio  
Fischentschupper  
Ecailleur double  
Raspador de escamas doble

art. cm.

48280-37 22,5x3,5



**Cheese slicer**

Affetta formaggio  
Käsehobel  
Coupe-fromage  
Cortador de queso

art. cm.

48280-41 25x7,6



**Cheese cleaver**

Mannaietta per formaggio  
Käsemesser  
Couperet à fromage  
Hachita para queso

art. cm.

48280-49 21x4



**Cheese knife**

Coltello formaggio  
Käsemesser  
Couteau à fromage  
Cuchillo para queso

art. l. cm.

48280-59 27



**Parmesan cheese knife**

Coltello parmigiano  
Parmesankäsemesser  
Couteau à Parmesan  
Cuchillo para queso parmesano

art. l. cm.

48280-46 24



**Butter spreader**

Spalmburro  
Butterstreicher  
Tartineur  
Cuchillo mantequilla

art. l. cm.

48280-75 21,5



**Vegetable sharpener**

Temperino per verdure  
Spiralschneider  
Taille crayon légumes  
Afilador para vegetales

art. Ø cm.

48280-12 4,5

48280-13 7,0



**Silicone basting brush**

Pennello in silicone  
Backpinsel, Silikon  
Pinceau, silicone  
Pincel pastelería, silicona

art. cm.

48280-09 25,5x4



**Basting brush**

Pennello  
Backpinsel  
Pinceau  
Pincel pastelería

art. cm.

48280-94 22,5x3,5



**Cheese grater**

Grattugia formaggio  
Käseraffel  
Râpe à fromage  
Rallador de queso

art. l. cm.

48280-06 24





**Bottle opener**

Levacapsule  
Flaschenöffner  
Décapsuleur  
Abrebotellas

| art.     | l. cm. |
|----------|--------|
| 48280-02 | 19     |



**Can opener**

Apriscatole  
Flügeldosenöffner  
Ouvre-boîtes  
Abrelatas

| art.     | cm.    |
|----------|--------|
| 48280-03 | 22x4,6 |



**Melon baller**

Scavino  
Kugelausstecher  
Moule à pomme  
Vaciador

| art.     | Ø cm. | l. cm. |
|----------|-------|--------|
| 48280-24 | 1,0   | 19,0   |
| 48280-30 | 1,5   | 19,0   |
| 48280-31 | 2,0   | 19,0   |
| 48280-35 | 2,3   | 19,5   |
| 48280-36 | 3,0   | 19,5   |



**Double melon baller**

Scavino doppio  
Kugelausstecher, doppel  
Moule à pomme, double  
Vaciador doble

| art.     | Ø cm.   | l. cm. |
|----------|---------|--------|
| 48286-67 | 2,2-3,0 | 17     |



**Oval melon baller**

Scavino ovale  
Kugelausstecher, oval  
Moule à pomme, ovale  
Vciador oval

| art.     | Ø cm. | l. cm. |
|----------|-------|--------|
| 48280-26 | 1,9   | 19,5   |



**Zucchini corer, dented**

Svuota zucchine  
Zucchini-Entkerner  
Vide-courgettes  
Vaciador de zucchini

| art.     | l. cm. |
|----------|--------|
| 48280-54 | 24,5   |



**Pineapple coring tool**

Svuota ananas  
Ananasausstecher  
Vide-ananas  
Descorazonador de piña

| art.     | l. cm. |
|----------|--------|
| 48280-10 | 25     |



**Asparagus peeler**

Pela asparagi  
Spargelschäler  
Éplucheur à asperges  
Pelador de espárragos

| art.     | l. cm. |
|----------|--------|
| 48280-85 | 23,5   |



**Tomato peeler**

Pela pomodori  
Tomatenschäler  
Éplucheur à tomates  
Pelador de tomates

art. l. cm.

48280-08 18



**Y-shaped swivel peeler**

Sbucciatore a lama mobile  
Pendelschäler  
Éplucheur à lame pivotante  
Pelador oscilante

art. l. cm.

48280-53 18,5

48280-52 21,0



**Melon peeler**

Sbuccia melone  
Melonenschäler  
Éplucheur à melon  
Pelador de melon

art. Ø cm. l. cm.

48280-60 8,0 20

48280-61 9,0 21

48280-62 10,5 22

48280-63 12,0 23



**Potato peeler**

Pelapatate  
Kartoffelschäler  
Éplucheur  
Pelador de patatas

art. l. cm.

48280-34 19,5



**Orange peeler**

Pelorange  
Orangenschäler  
Éplucheur à orange  
Pelador de naranjas

art. l. cm.

48280-96 20



**Grapefruit knife**

Coltello per pompelmo  
Grapefruitmesser  
Couteau à pamplemousse  
Cuchillo para pomelo

art. l. cm.

48280-47 21,5



**Citrus bar knife**

Coltello bar  
Bar Messer  
Couteau bar  
Cuchillo bar

art. l. cm.

48280-97 23



**Fruit scoop**

Cucchiaio scavino frutta  
Fruchtlöffel  
Cuillère à évider pour fruits  
Cuchara ahueca frutas

art. l. cm.

48280-15 20



**Butter curler**

Arricciaburro  
Butterroller  
Coquilleur à beurre  
Rizador de mantequilla

art. l. cm.

48280-11 22,5



**Fruit decorator knife**

Coltello decora frutta  
Fruchtdekoriermesser  
Couteau denteleur  
Cuchillo para decorar fruta

art. l. cm.

48280-91 23



**Citrus stripper**  
Decoratore  
Ziseliermesser  
Canneleur  
Rallador de cítricos  
art. l. cm.  
48280-95 16,5



**Citrus zester stripper**  
Rigalimoni decoratore  
Zester Ziseliermesser  
Zesteur canneleur  
Acanalador rallador cítricos  
art. l. cm.  
48280-92 17



**Citrus zester**  
Rigalimoni  
Zester  
Zesteur  
Acanalador de cítricos  
art. l. cm.  
48280-90 17



**Apple corer**  
Levatorsoli  
Entkerner  
Vide-pomme  
Descorazonador  
art. Ø cm. l. cm.  
48280-25 1,2 21



**Wavy vegetable cutter**  
Tagliaverdure ondulato  
Wellenschneider  
Coupe-légumes ondulé  
Cortador de verduras ondulado  
art. l. cm.  
48280-23 11,5



**Coil whisk**  
Frusta a spirale  
Spiral Schneebesen  
Fouet à spirale  
Batidor espiral  
art. Ø cm. l. cm.  
48278-24 5 26,5



**Pizza wheel**  
Rotella tagliapizza  
Pizzaschneider  
Roulette à pizza  
Ruedecilla pizza  
art. Ø cm. l. cm.  
48278-33 7 21



**Pastry wheel**  
Rotella tagliapasta  
Teigrädchen  
Roulette à pâte  
Ruedecilla para pasta  
art. Ø cm. l. cm.  
48278-32 4 18



**Double pastry wheel**  
Rotella tagliapasta doppia  
Doppel-Teigrädchen  
Roulette a pâte double  
Ruedecilla para pasta doble  
art. Ø cm. l. cm.  
48278-39 4 18



**Fish scaler**  
Squamapesce  
Fischentschupper  
Ecailleur  
Quita escamas  
art. l. cm.  
48278-38 22



**Paring knife**

Spelucchino  
Spickmesser  
Couteau d'office  
Cuchillo mondador

art. l. cm.  
48278-55 22,5



**Conical colander**

Colino conico  
Spitzsieb  
Passoire chinois  
Colador cónico

art. Ø cm. l. cm.  
48278-13 16 35



**Strainer**

Colino  
Sieb  
Passoire  
Colador

art. Ø cm. l. cm.  
48278-12 8 27



**Vegetable knife**

Coltello verdure  
Gemüsemesser  
Couteau à légumes  
Cuchillo para verduras

art. l. cm.  
48278-48 19



**Soft cheese slicer**

Affetta formaggio tenero  
Weichkäsehobel  
Coupe-fromage à pâte molle  
Cortador de queso blando

art. cm.  
48278-42 20x7,5



**Cheese cleaver**

Mannaietta per formaggio  
Käsemesser  
Couperet à fromage  
Hachita para queso

art. cm.  
48278-49 21x4



**Parmesan cheese knife**

Coltello parmigiano  
Parmesankäsemesser  
Coutau à Parmesan  
Cuchillo queso parmenso

art. l. cm.  
48278-46 23,5



**Cheese slicer**

Affetta formaggio  
Käsehobel  
Coupe-fromage  
Cortador de queso

art. l. cm.  
48278-41 25







**Potato masher**

Pressapatate  
Kartoffelstampfer  
Presse-purée  
Prensador de patatas

art. cm. l. cm.  
48278-87 8x7 27



**Potato masher**

Pressapatate  
Kartoffelstampfer  
Presse-purée  
Prensador de patatas

art. cm.  
48278-31 27x8



**Butter spreader**

Spalmaburro  
Butterstreicher  
Tartineur  
Cuchillo mantequilla

art. l. cm.  
48278-75 21



**Grater**

Grattugia  
Raffel  
Râpe  
Rallador

art. cm.  
48278-20 25,5x5,5



**Grater**

Grattugia  
Raffel  
Râpe  
Rallador

art. cm.  
48278-21 25,5x5,5



**Oyster knife**

Coltello apriostriche  
Austernmesser  
Couteau à huîtres  
Cuchillo para ostras

art. l. cm.  
48278-45 20



**Straight icing spatula**

Spatola per glassa  
Glasurpalette  
Spatule glaçage plate  
Espátula pastelera

art. l. cm.  
48278-77 27,5



**Basting brush**

Pennello  
Backpinsel  
Pinceau cuisine  
Pincel pastelería

art. l. cm.  
48278-94 22



**Garlic press**

Spremiaglio  
Knoblauchpresse  
Presse-ail  
Prensador de ajo

art. cm.  
48278-37 19x5



**Jar opener**

Apribarattoli  
Einmachglasöffner  
Ouvre-bocal  
Abridor de tarros

art. cm.  
48278-01 25,5x8,5



**Bottle opener**

Levacapsule  
Flaschenöffner  
Ouvre-bouteille  
Abrebotellas

art. cm.  
48278-02 19x3,7



**Zucchini corer**

Svuota zucchine  
Zucchini-Entkerner  
Vide-courgettes  
Vaciador de zucchini

art. l. cm.  
48278-54 25



**Swivel peeler**

Sbucciatore a lama mobile  
Pendelschäler  
Éplucheur à lame pivotante  
Pelador oscilante

art. l. cm.  
48278-52 21



**Y-shaped swivel peeler**

Sbucciatore a Y  
Y-Pendelschäler  
Éplucheur  
Pelador Y

art. l. cm.  
48278-53 18,5



**Apple corer**

Levatorsoli  
Apfelentkerner  
Vide-pomme  
Descorazonador de manzana

art. Ø cm. l. cm.  
48278-25 1,6 21,5



**Potato fork 3 prongs**

Forchettina patate 3 punte  
Pellkartoffelgabel 3 Zinken  
Fourchette à pommes de terre  
Tenedor tridente para patatas

art. l. cm.  
48278-17 16,5



**Can opener**

Apriscatole  
Flügeldosenöffner  
Ouvre-boîte  
Abrelatas

art. cm.  
48278-03 22x4,6



**Potato peeler**

Pelapatate  
Kartoffelschäler  
Éplucheur  
Pelador de patatas

art. l. cm.  
48278-34 19,5



**Melon baller**

Scavino  
Kugelausstecher  
Moule à pomme  
Vaciador

art. Ø cm. l. cm.  
48278-35 3 18



**Orange peeler**

Pelarance  
Orangenschäler  
Éplucheur à orange  
Pelador de naranja

art. l. cm.  
48278-96 20



**Grapefruit knife**

Coltello per pompelmo  
Grapefruitmesser  
Couteau à pamplemousse  
Cuchillo para pomelo

art. l. cm.  
48278-47 21,5



**Ice cream scoop**

Porzionatore gelato  
Eisportionierer  
Cuiillère à glace  
Porcionador para helado

art. Ø cm. l. cm.  
48278-95 4 21





**Coffee measuring spoon**

Dosacaffè  
Kaffeedosierlöffel  
Cuillère doaseuse à café  
Cuchara dosificador de café

art. Ø cm. l. cm.  
48278-16 3,5 20



**Fruit decorator knife**

Coltello decora frutta  
Fruchtdekoriermesser  
Couteau denteleur  
Cuchillo para decorar frutas

art. l. cm.  
48278-91 22,5



**Citrus zester stripper**

Rigalimoni decoratore  
Zester Ziseliermesser  
Zesteur canneleur  
Acanalador rallador cítricos

art. l. cm.  
48278-92 16,5



**Odor eliminator soap bar**

Saponetta toglì odori  
Geruch Entferner Seife  
Savonette enlève odeurs  
Jabón quita odores

art. cm.  
48278-99 7,5x5,5



**Soup ladle**

Mestolo  
Schöpflöffel  
Louche à soupe  
Cazo sopa

art. Ø cm. l. cm.  
48278-69 9 32  
48278-66 6 29



**Salad spoon**

Cucchiaio per insalata  
Salatlöffel  
Cuillère à salade  
Cucharón ensalada

art. Ø cm. l. cm.  
48278-62 5 25



**Egg separator**

Separauova  
Eiertrenner  
Séparateur d'oeuf  
Separador de huevos

art. Ø cm. l. cm.  
48278-36 5,5 20,5



**Cocktail spoon**

Cucchiaio cocktail  
Cocktailöffel  
Cuiller à cocktail  
Cuchara cóctel

art. Ø cm. l. cm.  
48278-15 6 28



**Butter curler**

Arricciaburro  
Butterroller  
Coquilleur à beurre  
Rizador de mantequilla

art. l. cm.  
48278-11 21,5



**Sauce ladle**

Mestolino salsa  
Saucenlöffel  
Louche à sauce  
Cacillo salsas

art. Ø cm. l. cm.  
48278-68 7 29



**Salad serving fork**

Forchetta servire insalata  
Salatserviergabel  
Fourchette à servir salade  
Tenedor servir ensalada

art. Ø cm. l. cm.  
48278-64 5 25,5

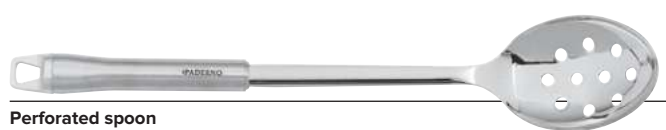

**Perforated spoon**

Cucchiaio forato  
Giesslöffel, perforiet  
Cuillère percée  
Cuchara perforada

art. cm.  
48278-61 34x6

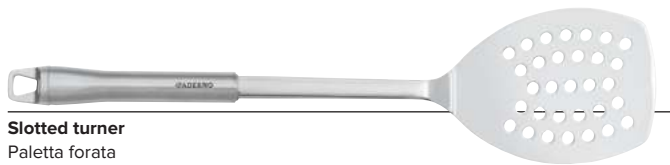

**Slotted turner**

Paletta forata  
Küchenwender, perforiert  
Pelle ajourée  
Espátula perforada

art. cm.  
48278-71 34,5x8,5

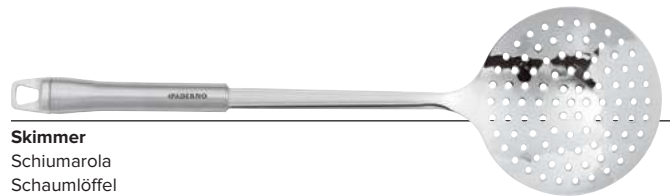

**Skimmer**

Schiumarola  
Schaumlöffel  
Ecumoire  
Espumadera

art. Ø cm. l. cm.  
48278-73 11 37



**Spatula**

Spatola  
Spachtel  
Spatule  
Espátula

art. cm.  
48278-76 28,5x5,6



**Cake server**

Pala torta  
Tortenheber  
Pelle à tarte  
Pala tarta

art. cm.  
48278-93 26x5,8

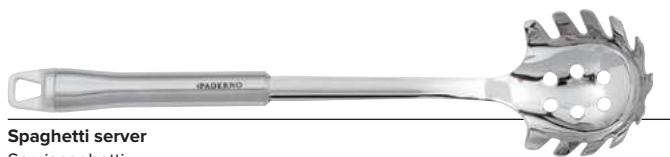

**Spaghetti server**

Servispaghetti  
Spaghettilöffel  
Cuillère à spaghetti  
Servidor para espagueti

art. Ø cm. l. cm.  
48278-74 7 30,5



**Meat fork**

Forchettone  
Fleischgabel  
Fourchette à viande  
Tenedor trinchar

art. l. cm.  
48278-65 32,5



**Rice spoon**

Cucchiaio risotto  
Reislöffel  
Cuillère de service à riz  
Cuchara arroz

art. l. cm.  
48278-63 27



**Spatula**

Spatola lasagne  
Lasagne Spatel  
Palette  
Espátula lasaña

art. cm.  
48278-27 29x4,5



**Skimmer**

Schiumarola  
Schaumlöffel  
Ecumoire  
Espumadera

art. Ø cm. l. cm.  
48278-88 11 36,5



**Soup ladle**

Mestolo  
Schöpflöffel  
Louche à soupe  
Cazo sopa

art. Ø cm. l. cm.  
48278-84 9,5 32,5







**Rice spoon**

Cucchiaio riso  
Reislöffel  
Cuillère de service à riz  
Cuchara arroz

art. cm.  
48278-82 33x6,5

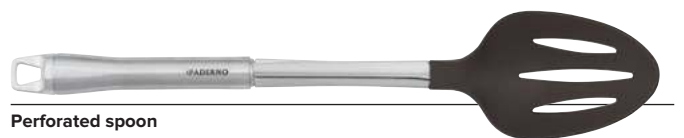

**Perforated spoon**

Cucchiaio forato  
Gießlöffel, perforiert  
Cuillère percée  
Cuchara perforada

art. cm.  
48278-81 33x6,5

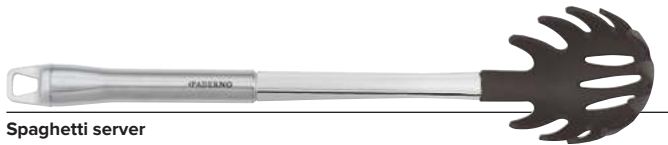

**Spaghetti server**

Servispaghetti  
Spaghettillöffel  
Cuillère à spaghetti  
Servidor para espagueti

art. cm.  
48278-89 32x6,5



**Meat fork**

Forchettone  
Fleischgabel  
Fourchette à viande  
Tenedor trinchar

art. l. cm.  
48278-83 32,5



**Silicone basting spoon**

Cucchiaione in silicone  
Gießlöffel aus Silikon  
Cuillère de service en silicone  
Cuchara para servir de silicona

art. cm. l. cm.  
48278-14 5,5x8 26,5



**Perforated spatula**

Paletta forata  
Küchenwender, perforiert  
Pelle ajourée  
Pala perforada

art. cm.  
48278-85 33x8,5



**Silicone dough scraper**

Spatola in silicone  
Teigschaber aus Silikon  
Pelle en silicone  
Paleta de silicona

art. cm. l. cm.  
48278-28 5x9 28,5

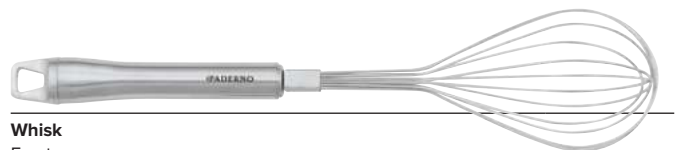

**Whisk**

Frusta  
Schneebesen  
Fouet  
Batidor

art. l. cm.  
48278-18 24,5  
48278-19 29,5

# TURNERS SPATOLE

KITCHEN UTENSILS  
UTENSILI DA CUCINA

SS PP



Stainless steel turners with polypropylene handle.

Spatole in acciaio inox con manico in polipropilene.



**Pizza server**  
Spatola per pasticcio e pizza  
Pizzawender  
Pelle à pizza  
Espátula pizza

art. cm.  
18511-15 15,5x8,7



**Hamburger turner**  
Spatola hamburger  
Hamburgerspachtel  
Pelle à hamburger  
Espátula hamburguesa

art. cm.  
18512-15 19x13,8



**Lasagne spatula**  
Spatola lasagne  
Lasagneheber  
Pelle à lasagne  
Espátula lasaña

art. cm.  
18515-16 16,8x7,2



**Triangular spatula**  
Spatola triangolare  
Dreieckiger Spachtel  
Spatule triangulaire  
Espátula triangular

| art.     | cm.   |
|----------|-------|
| 18520-04 | 12x4  |
| 18520-06 | 12x6  |
| 18520-08 | 12x8  |
| 18520-10 | 12x10 |
| 18520-12 | 12x12 |



**Hamburger turner**  
Spatola hamburger  
Pfannenwender  
Grand palette à hamburger  
Espátula hamburguesa

| art.     | cm.    |
|----------|--------|
| 18516-24 | 24x7,2 |



**Perforated hamburger turner**  
Spatola hamburger, forata  
Pfannenwender, gelocht  
Grand palette perforée  
Espátula hamburguesa, perforada

| art.     | cm.    |
|----------|--------|
| 18517-24 | 24x7,2 |



**Perforated turner**  
Paletta forata  
Kuchenpalette, geschlitzt  
Palette perforée  
espátula perforada

| art.     | cm.    |
|----------|--------|
| 18510-07 | 13,5x7 |



**Slotted spatula**  
Spatola forata  
Pfannenpalette, geschlitzt  
Palette ajourée  
espátula perforada

| art.     | cm.    |
|----------|--------|
| 18509-01 | 16x7,5 |



**Slotted spatula**  
Spatola forata  
Pfannenwender, geschlitzt  
Palette ajourée  
espátula perforada

| art.     | cm.    |
|----------|--------|
| 18509-02 | 15,6x5 |



**Slotted spatula, flexible**  
Paletta forata, flessibile  
Pfannenwender, geschlitzt, flexibel  
Palette ajourée flexible  
espátula perforada flexible

| art.     | cm.      |
|----------|----------|
| 18509-03 | 15,6x8,7 |



**Bent icing spatula**  
Spatola cuoco con scalino  
Confiseriepalette  
Palette coudée  
Espátula pastelera acodada

| art.     | cm.    |
|----------|--------|
| 18518-22 | 22x3,4 |
| 18518-26 | 25x3,7 |
| 18518-30 | 30x4,3 |



**Straight icing spatula**  
Spatola cuoco  
Back- und Glasurpalette  
Spatule glaçage plate  
Espátula pastelera lisa

| art.     | cm.    |
|----------|--------|
| 18519-15 | 15,5x3 |
| 18519-22 | 22x3,4 |
| 18519-26 | 26x3,7 |
| 18519-30 | 31x4,3 |
| 18519-35 | 36x5   |



**Pie server**  
Paletta dolci  
Gebäckpalette  
Palette à gâteau  
Espátula pasteles

| art.     | cm.      |
|----------|----------|
| 18513-14 | 14,5x6,5 |



**Pie server serrated edge**  
Pala torta seghettata  
Kuchenschaukel gezackte Kante  
Pelle à gâteau côté dentelé  
Pala pasteles filo dentado

| art.     | cm.      |
|----------|----------|
| 18514-17 | 16,3x5,8 |



**Pie server serrated edge**  
Pala torta seghettata  
Kuchenschaukel gezackte Kante  
Pelle à gâteau côté dentelé  
Pala pasteles filo dentado

| art.     | cm.      |
|----------|----------|
| 18514-18 | 17,3x5,8 |

**Bent. – Con scalino.**

# LADLES MESTOLI

KITCHEN UTENSILS  
UTENSILI DA CUCINA



**The PADERNO ladle.**  
Handle-cup connection (one piece ladle). Thicker handle with rounded border.  
Diameter and capacity stamped on the handle.

**Il mestolo PADERNO.**  
Accoppiamento manico-coppa (mestolo unipezzo). Manico con spessore maggiorato con bordi arrotondati. Indicazione sul manico del diametro e della capacità.





**One piece ladle**  
Mestolo unipezzo  
Schöpflöffel, fugenlos  
Louche monobloc  
Cacillo monobloc

| art.     | Ø cm. | l. cm. | lt.  |
|----------|-------|--------|------|
| 11970-06 | 6,5   | 30     | 0,07 |
| 11970-08 | 8,0   | 32     | 0,12 |
| 11970-09 | 9,0   | 33     | 0,20 |
| 11970-10 | 10,0  | 37     | 0,25 |
| 11970-11 | 11,0  | 38     | 0,33 |
| 11970-12 | 12,0  | 40     | 0,50 |
| 11970-14 | 14,0  | 44     | 0,75 |
| 11970-16 | 16,0  | 47     | 1,00 |



**Ladle, tube handle**  
Mestolo con manico a tubo  
Schöpflöffel mit Rohrstiell  
Louche avec manche tubulaire  
Cacillo con mango tubolar

| art.     | Ø cm. | l. cm. | lt. |
|----------|-------|--------|-----|
| 11968-18 | 18    | 75     | 1,5 |
| 11968-20 | 20    | 75     | 2,0 |
| 11968-24 | 24    | 75     | 4,0 |



**One piece perforated ladle**  
Mestolo forato unipezzo  
Gelochter Schöpflöffel, fugenlos  
Louche monobloc perforée  
Cacillo monobloc perforado

| art.     | Ø cm. | l. cm. | lt.  |
|----------|-------|--------|------|
| 11967-06 | 6,5   | 30     | 0,07 |
| 11967-08 | 8     | 32     | 0,12 |
| 11967-09 | 9     | 33     | 0,20 |
| 11967-10 | 10    | 37     | 0,25 |
| 11967-12 | 12    | 40     | 0,50 |
| 11967-14 | 14    | 44     | 0,75 |
| 11967-16 | 16    | 47     | 1,00 |



**Perforated ladle, tube handle**  
Mestolo forato con manico a tubo  
Schöpflöffel, gelocht mit Rohrstiell  
Louche perforée, manche tubulaire  
Cacillo perforado mango tubolar

| art.     | Ø cm. | l. cm. | lt. |
|----------|-------|--------|-----|
| 11967-18 | 18    | 75     | 1,5 |
| 11967-20 | 20    | 75     | 2,0 |
| 11967-24 | 24    | 75     | 4,0 |



**One piece side basting spoon**  
Mestolo becco a versare unipezzo  
Saucenkelle quer, fugenlos  
Cuillère à arroser monobloc  
Cacillo monobloc para versar

| art.      | Ø cm. | l. cm. | lt.  |
|-----------|-------|--------|------|
| 11969-06  | 6,5   | 30     | 0,07 |
| 11969-37* | 6,5   | 30     | 0,07 |

\*Left handed. – Per mancini.



**One piece basting spoon**  
Cucchiaione unipezzo  
Giesslöffel, fugenlos  
Cuillère monobloc  
Cucharón monobloc

| art.     | l. cm. |
|----------|--------|
| 11982-38 | 38     |



**One piece perforated spoon**  
Cucchiaione forato unipezzo  
Giesslöffel perforiert, fugenlos  
Cuillère perforée monobloc  
Cucharón perforado monobloc

| art.     | l. cm. |
|----------|--------|
| 11984-38 | 38     |



**One piece spoon, crosswise**  
Cucchiaione obliquo unipezzo  
Giesslöffel quer, fugenlos  
Cuillère oblique monobloc  
Cucharón obliquo monobloc

| art.      | l. cm. |
|-----------|--------|
| 11983-38  | 38     |
| 11983-37* | 38     |

\*Left handed. – Per mancini.



**One piece meat fork, 3 prongs**  
Forchettone 3 denti unipezzo  
Fleischgabel 3 Zacken, fugenlos  
Fourchette 3 dents, monobloc  
Tenedor 3 dientes, monobloc

| art.     | l. cm. |
|----------|--------|
| 11974-50 | 50     |
| 11974-70 | 70     |



NSF  
SS

**One piece meat fork, 2 prongs**  
Forchettone 2 denti unipezzo  
Fleischgabel 2 Zacken, fugenlos  
Fourchette 2 dents, monobloc  
Tenedor 2 dientes, monobloc

| art.     | l. cm. |
|----------|--------|
| 11975-50 | 50     |
| 11975-99 | 100    |



NSF  
SS

**One piece spatula**  
Paletta liscia unipezzo  
Backschaufel, fugenlos  
Spatule monobloc  
Espátula lisa monobloc

| art.     | cm. | l. cm. |
|----------|-----|--------|
| 11972-10 | 10  | 36     |
| 11972-12 | 12  | 39     |



NSF  
SS

**One piece perforated spatula**  
Paletta forata unipezzo  
Backschaufel perforiert, fugenlos  
Spatule perforée monobloc  
Espátula perforada monobloc

| art.     | cm. | l. cm. |
|----------|-----|--------|
| 11973-10 | 10  | 36     |
| 11973-12 | 12  | 39     |



NSF  
SS

**Perforated slice**  
Pala a ridurre  
Reduzierspatel  
Spatule à réduire  
Espátula para reducir

| art.     | cm.   | l. cm. |
|----------|-------|--------|
| 11976-50 | 12x15 | 50     |
| 11976-99 | 12x15 | 100    |



NSF  
SS

**One piece fish spatula**  
Paletta pesce unipezzo, forata  
Fischwender, fugenlos  
Pelle à poisson monobloc  
Pala pescado, monobloc

| art.     | cm.   | l. cm. |
|----------|-------|--------|
| 11985-34 | 15x20 | 42     |



NSF  
SS

**One piece skimmer**  
Schiumarola unipezzo  
Schaumlöffel, fugenlos  
Ecumoire monobloc  
Espumadera monobloc

| art.     | Ø cm. | l. cm. |
|----------|-------|--------|
| 11971-08 | 8     | 29,0   |
| 11971-10 | 10    | 32,0   |
| 11971-12 | 12    | 35,0   |
| 11971-14 | 14    | 38,0   |
| 11971-16 | 16    | 41,0   |
| 11971-18 | 18    | 42,5   |
| 11971-20 | 20    | 44,5   |



NSF  
SS

**One piece skimmer, tube handle**  
Schiumarola unipezzo, manico a tubo  
Schaumlöffel, fugenlos, mit Rohrstiel  
Ecumoire monobloc, manche tubulaire  
Espumadera monobloc, mango tubolar

| art.     | Ø cm. | l. cm. |
|----------|-------|--------|
| 11971-25 | 25    | 75     |



NSF  
SS

**One piece ladle**  
Mestolo unipezzo  
Schöpföffel, fugenlos  
Louche monobloc  
Cacillo monobloc

| art.     | Ø cm. | l. cm. | lt.  |
|----------|-------|--------|------|
| 11970-01 | 8     | 23     | 0,12 |

Short handle. – Manico corto.



NSF  
SS

**Side basting spoon**  
Mestolo con becco a versare  
Saucenkelle mit seitlichem Ausguß  
Cuillère à arroser  
Cacillo para versar

| art.     | Ø cm. | l. cm. | lt.  |
|----------|-------|--------|------|
| 11969-02 | 6,5   | 23     | 0,07 |

Short handle. – Manico corto.



NSF  
SS

**One piece spoon**  
Cucchiaione unipezzo  
Giesslöffel, fugenlos  
Cuillère monobloc  
Cuchara monobloc

| art.     | l. cm. |
|----------|--------|
| 11982-01 | 23,5   |

Short handle. – Manico corto.



NSF  
SS

**One piece meat fork**  
Forchettone unipezzo  
Fleischgabel, fugenlos  
Fourchette monobloc  
Tenedor monobloc

| art.     | l. cm. |
|----------|--------|
| 11975-01 | 26     |

Short handle. – Manico corto.



NSF  
SS

**One piece perforated spatula**  
Paletta forata unipezzo  
Backschaufel perforiert, fugenlos  
Spatule perforée monobloc  
Espátula perforada monobloc

| art.     | cm.   | l. cm. |
|----------|-------|--------|
| 11973-01 | 8x9,5 | 24     |

Short handle. – Manico corto.



NSF  
SS

**One piece skimmer**  
Schiumarola unipezzo  
Schaumlöffel, fugenlos  
Ecumoire monobloc  
Espumadera monobloc

art. Ø cm. l. cm.  
11971-01 9 26

**Short handle. – Manico corto.**



SS

**Ladle**  
Mestolo  
Schöpflöffel  
Louche  
Cacillo

art. Ø cm. l. cm. lt.  
41670-06 6 30 0,03  
41670-09 9 32 0,13



SS

**Skimmer**  
Schiumarola  
Schaumlöffel  
Ecumoire  
Espumadera

art. Ø cm. l. cm.  
41671-11 11 32



SS

**Slotted turner**  
Paletta forata  
Küchenwender, geschlitzt  
Pelle ajourée  
Espátula perforada

art. l. cm.  
41672-00 32



SS

**Spaghetti spoon**  
Cucchiaio per spaghetti  
Spaghettilöffel  
Cuillère à spaghetti  
Tenedor espaguetis

art. l. cm.  
41673-00 32



SS

**Meat fork**  
Forchettone  
Fleischgabel  
Fourchette  
Tenedor

art. l. cm.  
41674-00 32



SS

**Basting spoon**  
Cucchiaione  
Giesslöffel  
Cuillère  
Cuchara

art. l. cm.  
41675-00 32



SS

**Perforated spoon**  
Cucchiaione forato  
Schöpfkelle, gelocht  
Cuillère percée  
Cuchara perforada

art. l. cm.  
41676-00 32



SS

**Sauce ladle**  
Cucchiaione salse  
Saucenkelle  
Cuillère à sauce  
Cuchara salsas

art. l. cm.  
41677-00 32



SS

**Whisk**  
Frusta  
Schneebesen  
Fouet  
Batidor

art. l. cm.  
41678-00 30



SS

**Wall rack**  
Asta  
Aufhängungstange  
Tringle de cuisine  
Asta para utensilios

art. l. cm.  
41670-AA 40  
41670-AB 60



SS

**Mesh skimmer**  
Schiumarola a rete stirata  
Schaumlöffel  
Ecumoire  
Espumadera

art. Ø cm. l. cm.  
11990-16 16 40



SS

**Mesh skimmer**  
Schiumarola a rete passabrodo  
Schaumlöffel  
Ecumoire  
Espumadera

art. Ø cm. l. cm.  
11991-16 16 40

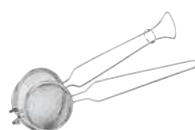

SS

**Bird nest fryer**  
Colafritto  
Nestbacklöffel  
Nid à friture  
Molde nido

art. Ø cm. l. cm.  
42623-10 10 26



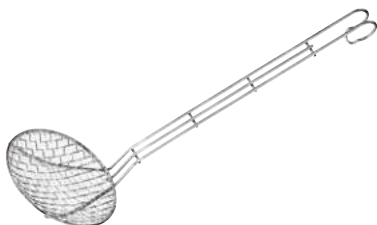

SS

**Wire skimmer**  
 Schiumarola a filo  
 Drahtlöffel  
 Araignée  
 Araña

| art.     | Ø cm. | l. cm. |
|----------|-------|--------|
| 12640-14 | 14    | 40     |
| 12640-16 | 16    | 40     |
| 12640-18 | 18    | 40     |
| 12640-20 | 20    | 50     |
| 12640-24 | 24    | 50     |
| 12640-28 | 28    | 50     |

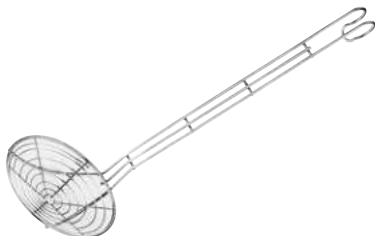

SS

**Wire skimmer**  
 Schiumarola a filo  
 Drahtlöffel  
 Araignée  
 Araña

| art.     | Ø cm. | l. cm. |
|----------|-------|--------|
| 12641-14 | 14    | 40     |
| 12641-16 | 16    | 40     |
| 12641-18 | 18    | 40     |
| 12641-20 | 20    | 50     |
| 12641-24 | 24    | 50     |
| 12641-28 | 28    | 50     |

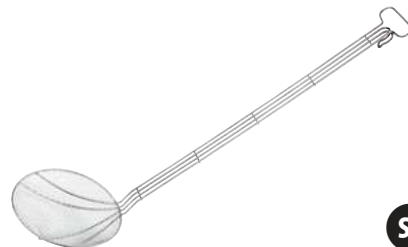

SS

**Wire skimmer**  
 Schiumarola a filo  
 Drahtlöffel  
 Araignée  
 Araña

| art.     | Ø cm. | l. cm. |
|----------|-------|--------|
| 12642-28 | 28    | 85     |



SS

**French fry scoop**  
 Pala per patate fritte  
 Frittenschaufel  
 Pelle à frites  
 Pala chips

| art.     | cm.       |
|----------|-----------|
| 41929-00 | 20x19x6,5 |



ABS

**French fry scoop**  
 Pala per patate fritte  
 Frittenschaufel  
 Pelle à frites  
 Pala chips

| art.     | cm.     |
|----------|---------|
| 41929-02 | 23x20x5 |

Ambidextrous. – Ambidestro.



W

**Spatula**  
 Spatola  
 Schäber  
 Spatule  
 Espátula

| art.     | l. cm. |
|----------|--------|
| 42907-01 | 25     |
| 42907-02 | 30     |
| 42907-03 | 35     |
| 42907-04 | 40     |
| 42907-06 | 50     |
| 42907-07 | 60     |
| 42907-08 | 80     |
| 42907-09 | 100    |
| 42907-10 | 120    |



W

**Mixing spoon**  
 Cucchiavione  
 Löffel  
 Cuillère  
 Cuchara

| art.     | l. cm. |
|----------|--------|
| 42901-20 | 20     |
| 42901-25 | 25     |
| 42901-30 | 30     |
| 42901-35 | 35     |
| 42901-40 | 40     |



W

**Spatula**  
 Spatola  
 Schäber  
 Spatule  
 Espátula

| art.     | l. cm. |
|----------|--------|
| 42907-30 | 30     |
| 42907-35 | 35     |
| 42907-40 | 40     |



W

**Crepe spreader, 5 pcs**  
 Spatole crêpes, 5 pz  
 Crêpe-Paletten, 5 Stk  
 Rateau à crêpes/raclettes, 5 pcs  
 Espátula crêpes, 5 pz

| art.     | cm.   |
|----------|-------|
| 42900-15 | 18x18 |
| 42900-24 | 18x24 |

Beachwood. – Faggio.





SS

**Baster tube**  
Pompetta per sugo  
Soft-Spritze  
Pompe à jus  
Bomba para jugo

| art.     | l. cm. |
|----------|--------|
| 42863-00 | 20     |



SS

PP

PS

**Marinating syringe, graduated**  
Siringa per marinata, graduata  
Marinierspritze, graduert  
Seringue à marinade, graduée  
Jeringa para marinar, graduada

| art.     | Ø cm. | l. cm. | ml. |
|----------|-------|--------|-----|
| 42862-00 | 3,5   | 24     | 30  |



SS

**Fish-bone remover**  
Pinza toglie lische  
Grätenentkerner  
Pince à arêtes  
Pinza para espinas

| art.     | l. cm. |
|----------|--------|
| 42592-01 | 12     |
| 42592-02 | 12     |

**01 thin bones, 02 thick bones.**  
01 lische fini, 02 lische grosse.



SS

**Cooking tongs**  
Pinza  
Kochzange  
Pince  
Pinza

| art.     | l. cm. |
|----------|--------|
| 42904-01 | 16     |



SS

**Cooking tongs**  
Pinza  
Kochzange  
Pince  
Pinza

| art.     | l. cm. |
|----------|--------|
| 42904-02 | 16     |



SS

**Cooking tongs**  
Pinza  
Kochzange  
Pince  
Pinza

| art.     | l. cm. |
|----------|--------|
| 42904-03 | 15     |



SS

**Sausage tongs**  
Pinza per grill  
Grill-und Wurstzange  
Pince à saucisses  
Pinza para barbacoa

| art.     | l. cm. |
|----------|--------|
| 41697-00 | 38     |



SS

**Cooking tongs**  
Pinza  
Kochzange  
Pince  
Pinza

| art.     | l. cm. |
|----------|--------|
| 42902-31 | 30     |



SS

**Cooking tongs**  
Pinza  
Kochzange  
Pince  
Pinza

| art.     | l. cm. |
|----------|--------|
| 42902-30 | 30     |



SS

**Grill tweezer**  
Molla per grill  
Grillzange  
Pince à grill  
Pinza para barbacoa

| art.     | l. cm. |
|----------|--------|
| 41698-22 | 22,5   |
| 41698-30 | 30,0   |
| 41698-40 | 40,0   |



SS

**Serving tongs**  
Pinza a servire  
Servierzange  
Pince à servir  
Pinza para servir

| art.     | l. cm. |
|----------|--------|
| 42854C25 | 25     |
| 42854C30 | 30     |



SS

**Serving tongs**  
Pinza a servire  
Servierzange  
Pince à servir  
Pinza para servir

| art.     | l. cm. |
|----------|--------|
| 42854B25 | 25     |
| 42854B30 | 30     |



SS

**Serving tongs**  
Pinza a servire  
Servierzange  
Pince à servir  
Pinza para servir

| art.     | l. cm. |
|----------|--------|
| 42854Y25 | 25     |
| 42854Y30 | 30     |



SS

**Serving tongs**  
Pinza a servire  
Servierzange  
Pince à servir  
Pinza para servir

| art.     | l. cm. |
|----------|--------|
| 42854K25 | 25     |
| 42854K30 | 30     |



SS

**Serving tongs**  
Pinza a servire  
Servierzange  
Pince à servir  
Pinza para servir

| art.     | l. cm. |
|----------|--------|
| 42854R25 | 25     |
| 42854R30 | 30     |



SS

**Serving tongs**  
Pinza a servire  
Servierzange  
Pince à servir  
Pinza para servir

| art.     | l. cm. |
|----------|--------|
| 42854G25 | 25     |
| 42854G30 | 30     |



**Cooking tongs, silicone**  
Pinza, silicone  
Kochzange aus Silikon  
Pince en silicone  
Pinza de silicona

| art.     | l. cm. |
|----------|--------|
| 42903-29 | 29     |



**Barbecue brush**  
Spazzola grill  
Grill-Bürste  
Brosse à grille  
Cepillo para barbacoa

| art.     | cm.    | l. cm. |
|----------|--------|--------|
| 41773-00 | 5,5x11 | 27     |

Brass bristles. – Setole in ottone.



SS

**Whisk for basin**  
Frusta gigante  
Kesselbesen  
Fouet à bassine  
Batidor gigante

| art.     | l. cm. |
|----------|--------|
| 41980-99 | 125    |



**Food-grade resin spatula**  
Spatola in resina alimentare  
Rührspaten für Speisenzubereitung  
Spatule en résine pour aliments  
Espátula de resina para alimentos

| art.     | cm.       | l. cm. |
|----------|-----------|--------|
| 44061-08 | 15,7x10,8 | 80     |
| 44061-09 | 23,5x10,8 | 90     |
| 44061-12 | 23,5x10,8 | 117    |
| 44061-14 | 23,5x10,8 | 137    |



SS

**Speed rack**  
Rastrelliera  
Flaschenregal  
Rack à bouteilles  
Rack de botellas

| art.     | cm.     | h.   | bot. |
|----------|---------|------|------|
| 44060-50 | 56x10,5 | 15,5 | 6    |
| 44060-80 | 81x10,5 | 15,5 | 8    |



SS

**Bill spike**  
Spillone portascontrini  
Kassenscheine-Aufstecknadel  
Pique-addition  
Pincha papeles

| art.     | Ø cm. | h. |
|----------|-------|----|
| 12504-20 | 9     | 20 |



W

**Bill spike**  
Spillone portascontrini  
Kassenscheine-Aufstecknadel  
Pique-addition  
Pincha papeles

| art.     | cm.   | l. cm. |
|----------|-------|--------|
| 42504-09 | 9x5,5 | 10,5   |



SS

**Tickets-holder**  
Asta portascontrini  
Bons-/Zettelhalter  
Porte-fiches à billes  
Barra de notas

| art.     | l. cm. |
|----------|--------|
| 42509-25 | 25     |
| 42509-50 | 50     |



SS

**Tab-grabber**  
Asta porta scontrini  
Bons-/Zettelhalter  
Porte-fiches  
Barra de notas

| art.     | l. cm. |
|----------|--------|
| 42509-60 | 60     |
| 42509-99 | 100    |



SS

**Roll holder**  
Porta rotolo  
Rollenhalter  
Derouleur papier  
Portarollos

| art.     | l. cm. |
|----------|--------|
| 42512-35 | 30     |



SS

**Wall film box**  
Supporto murale, porta pellicola  
Wand-Folien-Abreißgerät  
Dérouleur de film mural  
Soporte de pared para film

| art.     | l. cm. |
|----------|--------|
| 42513-30 | 30     |
| 42513-45 | 45     |

**Roll max ø cm 13. – Rotolo ø max. cm 13.**



PP

**Additional plate stand**  
Anello distanziatore  
Gestell für Zusatzteller  
Support assiette supplémentaire  
Soporte distanciador

| art.     | Ø cm. | h. |
|----------|-------|----|
| 47605-23 | 19-21 | 6  |



PP

**Plate cover**  
Copripiatto  
Tellerglocke  
Cloche  
Cubreplatos

| art.     | Ø cm. | h.  |
|----------|-------|-----|
| 47603-25 | 25    | 6,5 |
| 47603-27 | 27    | 6,5 |
| 44998-31 | 31    | 6,5 |



PC

**Plate cover**  
Copripiatto  
Tellerglocke  
Cloche  
Cubreplatos

| art.     | Ø cm. | h.  |
|----------|-------|-----|
| 44997-22 | 21    | 6,8 |
| 44997-24 | 23    | 6,8 |
| 44997-26 | 26    | 6,8 |
| 44997-28 | 28    | 6,8 |



NEW



SAN

**Plate cover**  
Copripiatto  
Tellerglocke  
Cloche  
Cubreplatos

| art.     | Ø cm. | h.  | for/per Ø |
|----------|-------|-----|-----------|
| 44991-22 | 22,0  | 7,0 | 21,5      |
| 44991-24 | 24,0  | 7,5 | 22,5-23   |
| 44991-28 | 28,0  | 6,5 | 26-26,5   |
| 44991-29 | 28,5  | 6,5 | 27-27,5   |



SS

**Plate cover**  
Copripiatto  
Tellerglocke  
Cloche  
Cubreplatos

| art.     | Ø cm. | h.  |
|----------|-------|-----|
| 41683-26 | 26,5  | 4,3 |



SS

**Funnel**  
 Imbuto  
 Trichter  
 Entonnoir  
 Embudo

| art.     | Ø cm. |
|----------|-------|
| 42562-12 | 12    |
| 42562-14 | 14    |
| 42562-16 | 16    |
| 42562-18 | 18    |
| 42562-20 | 20    |
| 42562-25 | 25    |
| 42562-30 | 30    |



PP

**Funnel**  
 Imbuto  
 Trichter  
 Entonnoir  
 Embudo

| art.     | Ø cm. |
|----------|-------|
| 47604-08 | 8     |
| 47604-10 | 10    |
| 47604-12 | 12    |
| 47604-15 | 15    |
| 47604-18 | 18    |
| 47604-20 | 20    |
| 47604-24 | 24    |
| 47604-30 | 30    |



PP

**Measuring jug**  
 Caraffa graduata  
 Messbecher  
 Pichet gradué  
 Jarra de medidas

| art.     | Ø cm. | h. | lt. |
|----------|-------|----|-----|
| 47608-02 | 19    | 12 | 2,2 |



PP

**Measuring jug**  
 Caraffa graduata  
 Messbecher  
 Pichet gradué  
 Jarra de medidas

| art.     | Ø cm. | h.   | lt.  |
|----------|-------|------|------|
| 47606-02 | 8,5   | 10,0 | 0,25 |
| 47606-05 | 10,5  | 10,5 | 0,50 |
| 47606-10 | 12,5  | 14,5 | 1,00 |
| 47606-20 | 13,5  | 17,0 | 2,00 |
| 47606-30 | 15,5  | 21,0 | 3,00 |
| 47606-50 | 19,0  | 24,0 | 5,00 |



PP

**Measuring jug**  
 Caraffa graduata  
 Messbecher  
 Pichet gradué  
 Jarra de medidas

| art.     | Ø cm. | h.   | lt. |
|----------|-------|------|-----|
| 47607-10 | 12,5  | 14,5 | 1   |
| 47607-20 | 13,5  | 17,0 | 2   |

**Lt. and ml. scale. Heat resistant up to 95°C.**  
 Scala in lt e ml. Resistente fino a 95°C.



SS

**Graduated measure jug**  
 Misurino graduato  
 Messbecher, graduert  
 Mesure graduée  
 Jarra de medidas

| art.     | Ø cm. | h. | lt. |
|----------|-------|----|-----|
| 42581-01 | 7,5   | 5  | 0,1 |
| 42581-03 | 10,0  | 7  | 0,3 |
| 42581-05 | 11,5  | 11 | 0,5 |
| 42581-10 | 15,0  | 13 | 1,0 |
| 42581-15 | 15,5  | 15 | 1,5 |
| 42581-20 | 17    | 19 | 2,0 |



SS

**Measuring spoons, 4 pcs**  
 Misurini set 4 pz  
 Messlöffel Set 4-tlg.  
 Cuillères à mesurer 4 pcs  
 Cucharas medidoras 4 pz

| art.     | ml.        |
|----------|------------|
| 42615-04 | 1-2,5-5-15 |



SS

**Measuring cups, 4 pcs**  
 Misurini set 4 pz  
 Messlöffel Set 4-tlg.  
 Cuillères à mesurer 4 pcs  
 Cucharas medidoras 4 pz

| art.     | ml.           |
|----------|---------------|
| 42616-04 | 60-80-125-250 |





**SS**

**Lever dispenser**

Dosatore  
Hebeldosierspender  
Distributeur à manette  
Dispensador

| art.     | Ø cm. | h.   |
|----------|-------|------|
| 41528-21 | 21    | 22,5 |
| 41528-22 | 22    | 18,0 |

**Suitable for 5 kg bucket. – Per bidone da kg 5.**



**AY**

**Dispenser**

Dosatore  
Dosierspender  
Doseur  
Dispensador

| art.     | ml.  |
|----------|------|
| 47609-02 | 250  |
| 47609-03 | 350  |
| 47609-09 | 950  |
| 47609-13 | 1350 |



**AY**

**Dispenser**

Dosatore  
Dosierspender  
Doseur  
Dispensador

| art.     | ml.  |
|----------|------|
| 47609-04 | 375  |
| 47609-07 | 750  |
| 47609-12 | 1250 |
| 47609-16 | 1650 |



**PE**

**Squeeze bottle**

Flacone dosatore  
Quetschflasche  
Flacon doseur  
Frasco dosificador

| art.     | ml. | col. |
|----------|-----|------|
| 41526-R1 | 240 | ●    |
| 41526-R2 | 360 | ●    |
| 41526-R3 | 720 | ●    |



**PE**

**Squeeze bottle**

Flacone dosatore  
Quetschflasche  
Flacon doseur  
Frasco dosificador

| art.     | ml. | col. |
|----------|-----|------|
| 41526-B1 | 240 | ○    |
| 41526-B2 | 360 | ○    |
| 41526-B3 | 720 | ○    |



**PE**

**Squeeze bottle**

Flacone dosatore  
Quetschflasche  
Flacon doseur  
Frasco dosificador

| art.     | ml. | col. |
|----------|-----|------|
| 41526-G1 | 240 | ●    |
| 41526-G2 | 360 | ●    |
| 41526-G3 | 720 | ●    |



**PE**

**Squeeze bottle, 4 pcs**

Flacone dosatore, 4 pz  
Quetschflasche, 4 Stk  
Flacon doseur, 4 pcs  
Frasco dosificador, 4 pz

| art.     | Ø cm. | h.  | ml. |
|----------|-------|-----|-----|
| 41526-01 | 3     | 8,5 | 30  |



**PE**

**Squeeze bottle, 4 pcs**

Flacone dosatore, 4 pz  
Quetschflasche, 4 Stk  
Flacon doseur, 4 pcs  
Frasco dosificador, 4 pz

| art.     | Ø cm. | h.  | ml. |
|----------|-------|-----|-----|
| 41526-02 | 3,5   | 9,5 | 50  |



**PE**

**Squeeze bottle**

Flacone dosatore  
Quetschflasche  
Flacon doseur  
Frasco dosificador

| art.     | Ø cm. | h. | ml. |
|----------|-------|----|-----|
| 41526-05 | 5,0   | 18 | 200 |
| 41526-06 | 5,5   | 19 | 350 |



PE

**Triple nozzle squeeze bottle**

Flacone dosatore, triplo ugello  
Quetschflasche mit Dreifachdüse  
Flacon doseur à trois becs  
Frasco dosificador 3 boquillas

| art.     | ml. | col. |
|----------|-----|------|
| 41520-08 | 235 | ○    |
| 41520-12 | 355 | ○    |
| 41520-16 | 470 | ○    |
| 41520-24 | 700 | ○    |



SS

**Decorating spoons 2 pcs**

Cucchiari decorazione 2 pz  
Dekoration-Löffel 2 Stk  
Cuillères pour décorer 2 pcs  
Cucharas para decoración 2 pz

| art.     | l. cm. |
|----------|--------|
| 47831-02 | 19-23  |



SS

**Flour scoop**

Sessola tonda  
Mehlschaufel  
Pelle à farine  
Librador

| art.     | lt.  |
|----------|------|
| 42609-10 | 0,10 |
| 42609-15 | 0,40 |
| 42609-20 | 1,00 |
| 42609-23 | 1,70 |
| 42609-25 | 2,80 |



PP

**Flour scoop**

Sessola  
Mehlschaufel  
Pelle à farine  
Librador

| art.     | cm.      | lt.  |
|----------|----------|------|
| 17610-01 | 20x7     | 0,10 |
| 17610-02 | 27,5x9,5 | 0,25 |
| 17610-05 | 32,5x12  | 0,50 |
| 17610-10 | 39x15    | 1,00 |



PA+  
plus

**Flour scoop**

Sessola  
Mehlschaufel  
Pelle à farine  
Librador

| art.     | cm.      | lt.  |
|----------|----------|------|
| 12940-02 | 27,5x9,5 | 0,25 |
| 12940-05 | 32,5x12  | 0,50 |
| 12940-10 | 39x15    | 1,00 |
| 12940-20 | 48x18    | 2,00 |
| 12940-25 | 50x19,5  | 2,50 |



SS

**Bread sieve**

Setaccio pane  
Brotsieb  
Tamis à pain  
Cernidor para pan

| art.     | Ø cm. | h. |
|----------|-------|----|
| 12604-22 | 22    | 8  |
| 12604-30 | 30    | 8  |
| 12604-34 | 34    | 8  |
| 12604-40 | 40    | 8  |

8 eye per inch. – 8 fori per 2,5 cm2.



SS

**Flour sieve**

Setaccio farina  
Mehlsieb  
Tamis à farine  
Cernidor para harina

| art.     | Ø cm. | h. |
|----------|-------|----|
| 12605-22 | 22    | 8  |
| 12605-30 | 30    | 8  |
| 12605-34 | 34    | 8  |
| 12605-40 | 40    | 8  |

20 eye per inch. – 20 fori per 2,5 cm2.



SS

**Sieve**

Setaccio infarina pesce  
Sieb  
Tamis  
Cernidor

| art.     | Ø cm. | h. |
|----------|-------|----|
| 12606-30 | 30    | 8  |
| 12606-34 | 34    | 8  |

4 eye per inch. – 4 fori per 2,5 cm2.



SS

**Sieve**

Setaccio rete pasticciare  
Sieb  
Tamis  
Cernidor

| art.     | Ø cm. | h. |
|----------|-------|----|
| 12607-22 | 22    | 8  |
| 12607-30 | 30    | 8  |
| 12607-34 | 34    | 8  |

10 eye per inch. – 10 fori per 2,5 cm2.



SS

**Kitchenbowl, with handles**

Bacinella conica con maniglie  
Schüssel mit Griffen  
Bassine conique avec anses  
Caldero cónico con asas

| art.     | Ø cm. | h.   | lt.  |
|----------|-------|------|------|
| 11955-32 | 32    | 16,0 | 8,8  |
| 11955-36 | 36    | 18,5 | 12,8 |
| 11955-40 | 40    | 20,0 | 17,0 |
| 11955-45 | 45    | 22,5 | 24,5 |
| 11955-50 | 50    | 24,0 | 32,5 |



SS

**Conical colander**

Colapasta tronco conico  
Gemüsesieher  
Passoire à légumes  
Colador cónico

| art.     | Ø cm. | h.   | lt.  |
|----------|-------|------|------|
| 11930-24 | 24    | 12,0 | 3,5  |
| 11930-28 | 28    | 14,0 | 5,5  |
| 11930-32 | 32    | 16,0 | 8,8  |
| 11930-36 | 36    | 18,5 | 12,8 |
| 11930-40 | 40    | 20,0 | 17,0 |
| 11930-45 | 45    | 22,5 | 24,5 |
| 11930-50 | 50    | 24,0 | 32,5 |



SS

**Conical colander**

Colapasta tronco conico  
Gemüsesieher  
Passoire à légumes  
Colador cónico

| art.     | Ø cm. | h.   | lt.  |
|----------|-------|------|------|
| 11927-24 | 24    | 12,0 | 3,5  |
| 11927-28 | 28    | 14,0 | 5,5  |
| 11927-32 | 32    | 16,0 | 8,8  |
| 11927-36 | 36    | 18,5 | 12,8 |
| 11927-40 | 40    | 20,0 | 17,0 |
| 11927-45 | 45    | 22,5 | 24,5 |
| 11927-50 | 50    | 24,0 | 32,5 |



SS

**Hemispherical mixing bowl**

Bacinella semisferica  
Schüssel  
Bassine demi-ronde  
Caldero semiesférico

| art.     | Ø cm. | lt.  |
|----------|-------|------|
| 11957-20 | 20    | 2,0  |
| 11957-25 | 25    | 3,7  |
| 11957-30 | 30    | 7,2  |
| 11957-35 | 35    | 10,5 |
| 11957-40 | 40    | 15,6 |



NSF

SS

**Kitchenbowl low**

Bacinella conica bassa  
Schüssel, flach  
Bassine  
Caldero cónico

| art.     | Ø cm. | h.   | lt.  |
|----------|-------|------|------|
| 12582-13 | 13,2  | 6,0  | 0,5  |
| 12582-17 | 16,5  | 7,5  | 1,0  |
| 12582-22 | 22,0  | 7,5  | 2,0  |
| 12582-24 | 24,0  | 9,5  | 3,0  |
| 12582-32 | 30,5  | 11,5 | 6,0  |
| 12582-34 | 32,5  | 14,0 | 8,0  |
| 12582-38 | 38,0  | 13,5 | 11,0 |
| 12582-40 | 40,0  | 15,0 | 14,0 |



NSF

SS

**Kitchenbowl high**

Bacinella conica alta  
Tiefe Schüssel  
Bassine haute  
Caldero cónico alto

| art.     | Ø cm. | h.   | lt.  |
|----------|-------|------|------|
| 12580-11 | 11,7  | 7,0  | 0,5  |
| 12580-17 | 15,5  | 9,0  | 1,0  |
| 12580-21 | 19,0  | 11,5 | 2,0  |
| 12580-24 | 22,0  | 12,0 | 3,0  |
| 12580-29 | 27,0  | 13,5 | 5,0  |
| 12580-30 | 29,0  | 15,0 | 6,0  |
| 12580-31 | 30,5  | 17,0 | 8,0  |
| 12580-36 | 35,5  | 18,5 | 11,0 |
| 12580-40 | 40,0  | 20,0 | 17,0 |
| 12580-45 | 45,0  | 22,0 | 25,0 |
| 12580-50 | 50,0  | 24,0 | 33,0 |



PA+  
plus

**Conical colander**

Colatutto tronco conico  
Gemüsesieher  
Passoire à légumes  
Colador cónico

| art.     | Ø cm. | h. | lt. |
|----------|-------|----|-----|
| 12950-32 | 32    | 16 | 8   |
| 12950-40 | 40    | 20 | 12  |



**Conical colander, aluminium**

Colapasta tronco conico, alluminio  
Gemüsesieher, Aluminium  
Passoire à légumes, alu  
Colador cónico, aluminio

| art.     | Ø cm. | h.   | lt.  |
|----------|-------|------|------|
| 16927-32 | 32    | 16,0 | 8,8  |
| 16927-36 | 36    | 18,5 | 12,8 |
| 16927-40 | 40    | 20,0 | 17,0 |
| 16927-45 | 45    | 22,5 | 24,5 |
| 16927-50 | 50    | 24,0 | 32,5 |



SS

**Colander**

Colapasta con cerchio  
Gemüsesieher  
Passoire à légumes  
Colador con base

| art.     | Ø cm. | h.   | lt.  |
|----------|-------|------|------|
| 11928-32 | 32    | 18,0 | 9,5  |
| 11928-36 | 36    | 19,0 | 12,0 |
| 11928-40 | 40    | 21,0 | 14,5 |



SS

**Strainer**

Colapasta semisferico  
Stielsieb  
Passoire hémispherique  
Colador semiesférico

| art.     | Ø cm. | h. | lt. |
|----------|-------|----|-----|
| 11926-22 | 22    | 12 | 2,7 |
| 11926-26 | 26    | 14 | 4,0 |



SS

**Strainer**

Colapasta  
Stielsieb  
Passoire  
Colador

| art.     | Ø cm. | h. | lt. |
|----------|-------|----|-----|
| 11924-18 | 18    | 11 | 2,8 |
| 11924-20 | 20    | 12 | 3,6 |
| 11924-22 | 22    | 13 | 5,0 |
| 11924-24 | 24    | 14 | 6,5 |
| 11924-28 | 28    | 15 | 9,3 |



**Strainer, aluminium**

Colapasta, alluminio  
Stielsieb, Aluminium  
Passoire, alu  
Colador, aluminio

| art.     | Ø cm. | h. | lt. |
|----------|-------|----|-----|
| 16924-20 | 20    | 11 | 3,2 |
| 16924-24 | 24    | 13 | 6,0 |
| 16924-28 | 28    | 15 | 9,3 |



PP

**Strainer**

Colapasta  
Stielsieb  
Passoire  
Colador

| art.     | Ø cm. |
|----------|-------|
| 47610-22 | 22    |
| 47610-26 | 26    |
| 47610-30 | 30    |



PP

**Strainer**

Colapasta  
Stielsieb  
Passoire  
Colador

| art.     | Ø cm. |
|----------|-------|
| 47610-18 | 18    |



PE

**Graduated bucket**

Secchio graduato  
Eimer mit Skala  
Seau gradué  
Cubo con medidas

| art.     | Ø cm. | h.   | lt. |
|----------|-------|------|-----|
| 49889-09 | 27    | 26,2 | 9   |
| 49889-12 | 29    | 29,0 | 12  |
| 49889-15 | 31    | 30,8 | 15  |

With spout. – Con becco.



SS

**Graduated bucket**

Secchio graduato  
Eimer mit Skala  
Seau gradué  
Cubo con medidas

| art.     | Ø cm. | h.   | lt. |
|----------|-------|------|-----|
| 41960-08 | 28,5  | 20,5 | 8   |
| 41960-10 | 30,0  | 25,0 | 10  |
| 41960-12 | 31,0  | 27,0 | 12  |
| 41960-15 | 32,5  | 31,0 | 15  |



SS

**Graduated bucket with bottom ring**

Secchio graduato con base  
Eimer mit Fuss u. Skala  
Seau gradué avec base  
Cubo con medidas y base

| art.     | Ø cm. | h.   | lt. |
|----------|-------|------|-----|
| 41961-10 | 30,0  | 26,5 | 10  |
| 41961-12 | 31,0  | 28,5 | 12  |
| 41961-15 | 32,5  | 32,5 | 15  |



SS

**Lid for bucket**

Coperchio per secchio  
Deckel für Eimer  
Couvercle pour seau  
Tapa para cubo

| art.     | Ø cm. |
|----------|-------|
| 41962-10 | 30,0  |
| 41962-12 | 31,0  |
| 41962-15 | 32,5  |





PP

**Mixing bowl**

Bacinella tonda  
Schüssel

Bassine ronde  
Caldero semiesférico

| art.     | Ø cm. | h.   | lt.  |
|----------|-------|------|------|
| 47600-16 | 16    | 7,0  | 0,9  |
| 47600-20 | 20    | 8,5  | 1,6  |
| 47600-24 | 24    | 10,0 | 2,8  |
| 47600-28 | 28    | 11,0 | 4,5  |
| 47600-32 | 32    | 12,5 | 6,5  |
| 47600-36 | 36    | 14,0 | 10,0 |
| 47600-40 | 40    | 15,5 | 13,5 |



PP

**Mixing bowl**

Bacinella tonda  
Schüssel

Bassine ronde  
Caldero semiesférico

| art.     | Ø cm. | h.   | lt.  |
|----------|-------|------|------|
| 47611-01 | 19,0  | 7,9  | 1,0  |
| 47611-03 | 24,0  | 11,5 | 2,5  |
| 47611-05 | 28,0  | 13,5 | 4,5  |
| 47611-06 | 32,5  | 14,7 | 6,0  |
| 47611-09 | 36,0  | 16,5 | 9,0  |
| 47611-13 | 40,0  | 18,5 | 13,0 |



PP

**Lid**

Coperchio  
Deckel

Couvercle  
Tapa

| art.     | Ø cm. |
|----------|-------|
| 47611-11 | 19,0  |
| 47611-14 | 24,0  |
| 47611-15 | 28,0  |
| 47611-16 | 32,5  |
| 47611-19 | 36,0  |
| 47611-23 | 40,0  |



SS

**Mixing bowl**

Bastardella semisferica  
Schnees Schlagkessel

Bassine hémisphérique  
Caldero con asas

| art.     | Ø cm. | h.   | lt.  |
|----------|-------|------|------|
| 11952-22 | 22    | 12,0 | 2,7  |
| 11952-26 | 26    | 14,0 | 4,0  |
| 11952-32 | 32    | 18,0 | 9,5  |
| 11952-36 | 36    | 20,5 | 14,0 |
| 11952-40 | 40    | 21,5 | 18,0 |



SS

**Mixing bowl without handles**

Bastardella senza maniglie

Schnees Schlagkessel ohne Griffe  
Bassine hémisphérique sans anses

Caldero sin asas

| art.     | Ø cm. | h.   | lt.  |
|----------|-------|------|------|
| 11951-22 | 22    | 12,0 | 2,7  |
| 11951-26 | 26    | 14,0 | 4,0  |
| 11951-32 | 32    | 18,0 | 9,5  |
| 11951-36 | 36    | 20,5 | 14,0 |
| 11951-40 | 40    | 21,5 | 18,0 |



SS

**Foot for mixing bowl**

Base per bastardella

Fuss für Schnees Schlagkessel  
Base pour bassine hémisphérique

Base para caldero

| art.     | Ø cm. | for/per Ø |
|----------|-------|-----------|
| 11953-16 | 16    | 22-26     |
| 11953-22 | 22    | 32-36-40  |



SS

**Kettle for mixing machines**

Bacinella per planetaria  
Schlagmaschinenkessel

Bol pour mélangeurs  
Caldero para batidera

| art.     | Ø cm. | h.   | lt.  |
|----------|-------|------|------|
| 11954-26 | 26    | 20,0 | 10,0 |
| 11954-30 | 30    | 25,0 | 16,0 |
| 11954-32 | 32    | 30,0 | 20,0 |
| 11954-36 | 36    | 28,5 | 25,0 |
| 11954-37 | 36    | 35,0 | 32,0 |
| 11954-40 | 40    | 35,5 | 40,0 |



SS

**Kitchen bowl with handle**

Tazzone con manico

Schlagschüssel mit Rohrstiel  
Bol avec manche

Cazo bombeado

| art.     | Ø cm. | h.   | lt. |
|----------|-------|------|-----|
| 41916-10 | 15    | 8,0  | 1,0 |
| 41916-15 | 17    | 9,0  | 1,2 |
| 41916-20 | 19    | 10,0 | 2,0 |



**Induction adapter**

Adattatore induzione

Induktion Adapterplatte  
Disque relais pour induction  
Adaptador para inducción

| art.     | Ø cm. |
|----------|-------|
| 41922-16 | 16    |
| 41922-22 | 20    |

**Removable handle in heat resistant material.**  
Manico estraibile in materiale termo resistente.



**Manual salad spinner**

Centrifuga manuale per verdura  
Salatschleuder  
Essoreuse manuelle à salade  
Centrifugadora de ensalada

| art.     | Ø cm. | h. | lt. |
|----------|-------|----|-----|
| 49888-10 | 33    | 43 | 12  |
| 49888-20 | 43    | 52 | 25  |



SS

**Soup strainer**

Colino a rete  
Suppensieb  
Passe-bouillon  
Colador a red

| art.     | Ø cm. | l. cm. |
|----------|-------|--------|
| 12622-07 | 7     | 12     |
| 12622-10 | 10    | 12     |
| 12622-12 | 12    | 17     |
| 12622-14 | 14    | 17     |
| 12622-16 | 16    | 17     |
| 12622-18 | 18    | 17     |
| 12622-20 | 20    | 17     |
| 12622-23 | 23    | 27     |
| 12622-26 | 26    | 27     |



SS

**Strainer, double mesh**

Colapasta doppia rete  
Passiersieb, doppelnetz  
Passoire, maille double  
Colador doble red

| art.     | Ø cm. | l. cm. |
|----------|-------|--------|
| 12633-16 | 16    | 17     |
| 12633-18 | 18    | 17     |
| 12633-20 | 20    | 17     |
| 12633-23 | 23    | 27     |
| 12633-26 | 26    | 27     |



SS

**Strainer**

Colatutto  
Sieb  
Passoire  
Colador multiuso

| art.     | cm.   | l. cm. |
|----------|-------|--------|
| 12630-22 | 22x18 | 19     |



SS

**Strainer**

Colino  
Sieb  
Passoire  
Colador

| art.     | Ø cm. |
|----------|-------|
| 41570-10 | 8     |



SS

**Strainer, reinforced**

Colapasta rinforzato  
Grossküchensieb mit Verstärkung  
Passoire renforcé  
Colador reforzado

| art.     | Ø cm. | l. cm. |
|----------|-------|--------|
| 12635-23 | 23    | 27     |
| 12635-26 | 26    | 27     |
| 12635-30 | 30    | 44     |
| 12635-35 | 35    | 44     |



SS

**Vegetable sieve**

Passaverdura  
Passiergerät  
Mini hache-tout  
Pasa verdura

| art.     | Ø cm. |
|----------|-------|
| 12638-20 | 20    |



SS

**Strainer**

Colatutto gigante  
Grossküchensieb  
Passoire géant  
Colador multiuso gigante

| art.     | Ø cm. | l. cm. |
|----------|-------|--------|
| 12636-32 | 32    | 60     |



SS

**Chinese colander**

Cornetto cinese  
Spitzsieb  
Passoire chinois  
Colador chino

| art.     | Ø cm. |
|----------|-------|
| 41925-14 | 14    |
| 41925-16 | 16    |
| 41925-18 | 18    |
| 41925-20 | 20    |
| 41925-22 | 22    |
| 41925-24 | 24    |
| 41925-26 | 26    |



SS

**Chinese colander stand**  
Supporto per cornetto cinese  
Träger für Spitzsieb  
Support chinois  
Soporte para colador chino

| art.     | Ø cm. | h. |
|----------|-------|----|
| 41933-18 | 18    | 28 |



SS

**Colander with wire gauze**  
Cornetto cinese a rete  
Gazensieb  
Chinois à gaze  
Colador chino a red

| art.     | Ø cm. |
|----------|-------|
| 11929-20 | 20    |
| 11929-24 | 24    |



SS

**Chinese colander with wire protection**  
Cornetto con protezione  
Spitzsieb mit Verstärkung  
Chinois à gaze avec renfort  
Colador chino con protección

| art.     | Ø cm. |
|----------|-------|
| 11932-20 | 20    |
| 11932-24 | 24    |



SS

**Chinese soup strainer**  
Collino conico a rete  
Suppen-Spitzsieb  
Passe-bouillon chinois  
Colador cónico a red

| art.     | Ø cm. |
|----------|-------|
| 41931-08 | 8     |
| 41931-14 | 14    |
| 41931-16 | 16    |
| 41931-18 | 18    |



**Bouillon cloth**  
Panno passabrodo  
Bouillonstoffsieb  
Etamine passe-bouillon  
Paño para pasar caldo

| art.     | cm.   | U. Pack |
|----------|-------|---------|
| 41932-05 | 87x70 | 5       |

**Twisted cotton cloth with seam.**  
Tela di cotone ritorto, orlata.



ABS

**Rice scoop**  
Porzionatore  
Reis-Portionierer  
Portionneur  
Racionador

| art.     | h.  | gr.     |
|----------|-----|---------|
| 42653-04 | 4,5 | 120-130 |



**PA+**  
plus

**Portion rings set 6 pcs**  
Anelli per impiattare set 6 pz  
Portionierspeiseringe 6-tlg  
Cercles portionneurs set 6 pcs  
Anillos porcionadores 6 pz

| art.     | Ø cm. | h.  |
|----------|-------|-----|
| 12943-13 | 3-12  | 3,5 |



**PA+**  
plus

**Portion rings set 6 pcs**  
Anelli per impiattare set 6 pz  
Portionierspeiseringe 6-tlg  
Cercles portionneurs set 6 pcs  
Anillos porcionadores 6 pz

| art.     | Ø cm. | h.  |
|----------|-------|-----|
| 12944-13 | 3-12  | 3,5 |



PP

**Bag clip**  
Clip chiudi sacco  
Verschluss-Clip  
Clip ferme sachet  
Pinza cierra bolsas

| art.     | l. cm. | pcs/pz |
|----------|--------|--------|
| 42908-24 | 24     | 1      |

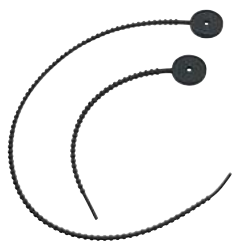

**Foodloops, silicone, 6 pcs**

Laccetti da cucina, silicone, 6 pz  
 Silikonbänder, 6 Stk  
 Lacets de cuisson, silicone, 6 pcs  
 Lazos de silicona de cocina, 6 pz

| art.     | l. cm. |
|----------|--------|
| 41595B44 | 22     |
| 41595B45 | 53     |



**Presse canard, bronzo**

Presse canard, bronzo  
 Presse canard, Bronze  
 Presse à canard, bronze  
 Prensador para canard, bronce

| art.     | h. | Kg. |
|----------|----|-----|
| 49845-01 | 52 | 16  |

Tinned. – Stagnato.



**Octopus-press**

Pressapolipo  
 Krake-Press  
 Presse à poulpe  
 Prensador para pulpo

| art.     | Ø cm. | h.   |
|----------|-------|------|
| 49760-00 | 10,5  | 20,5 |



**Mini-guitar**

Mini-chitarra  
 Mini-Guitare  
 Mini-guitare  
 Mini guitarra

| art.     | cm.      | Kg. |
|----------|----------|-----|
| 49839-00 | 45x23x15 | 4,9 |

For products with tender and homogeneous consistency. Cut width 14,5 cm, thickness 5 mm.  
 Per prodotti teneri ma di consistenza omogenea. Larghezza taglio 14,5 cm, spessore 5 mm.



**Mozzarella/tomato cutter**

Affetta mozzarella/pomodori  
 Mozzarella-/Tomatenschneidergerät  
 Coupe-mozzarella/tomates  
 Cortador mozzarella/tomates

| art.     | cm.      | Kg. |
|----------|----------|-----|
| 49820-05 | 48x20x32 | 7,1 |

Also suitable for cutting lemons, oranges or kiwis, etc. Slice thickness 5,5 mm.  
 Adatto anche per tagliare limoni, arance o kiwi, ecc. Spessore fetta 5,5 mm.







SS

**Tomato cutter**  
Affetta pomodori  
Tomatenschneidergerät  
Coupe-tomates  
Cortador tomates

| art.     | cm.      | Kg. |
|----------|----------|-----|
| 49837-05 | 30x14x18 | 2   |

**Slice thickness 5,5 mm. – Spessore taglio 5,5 mm.**



SS

**Cube cutter**  
Taglia cubi  
Würfel-Schneidergerät  
Coupe-cubes  
Cortador en dados

| art.     | cm.        | Kg. |
|----------|------------|-----|
| 49821-08 | 35,5x26x66 | 4   |

**Dice thickness 8 mm. – Spessore taglio 8 mm.**



SS

**Vegetable cutter**  
Taglia verdure  
Gemüseschneider  
Machine à tourner les légumes  
Cortador de verduras

| art.     | cm.        | Kg. |
|----------|------------|-----|
| 49842-00 | 21x17,5x19 | 3,2 |

**To make chateau potatoes, cocottes and fondants lenght from 4 to 8 cm. 3 position adjustable blade. – Per patate chateau, cocotte e fondanti di lunghezza da 4 a 8 cm. Lama con 3 regolazioni. di taglio.**



SS

**Fruit cutter**  
Trancia spicchi  
Früchteschneider  
Coupe-fruits  
Cortador tomates

| art.     | cm.      | Kg. |
|----------|----------|-----|
| 49838-08 | 38x26x58 | 3,3 |

**8 wedges, for vegetables and fruits without stone. – 8 spicchi, per ortaggi e frutta senza nocciolo.**



SS

**Apple corer/wedger set of blades**  
Set lame levatorsole e trancia spicchi  
Apfelentkerner-/Schneidmesser  
Lames évideur/coupe-pommes  
Saca corazón y cortador para manzanas

| art.     |
|----------|
| 49838-98 |

**8 sections. – 8 sezioni.**



SS

**Pineapple-peeler/corer**  
Pela/svuota ananas  
Ananasschälmaschine  
Epluche-ananas  
Pelador de piña

| art.     | cm.      | Kg. |
|----------|----------|-----|
| 49818-00 | 45x39x72 | 18  |

**Blade and pusher ø 89 mm.  
Lama e pressatore ø 89 mm.**



**Additional pushers and blades**  
Pressatori e lame opzionali  
Zusätzliche Presse und Messer  
Poussoirs et couteaux supplémentaires  
Empujador y cuchilla suplementarios

| art.     | des.       | Ø cm. |
|----------|------------|-------|
| 49818-AC | blade/lama | 7,4   |
| 49818-AD | pusher     | 7,4   |
| 49818-AE | blade/lama | 10,2  |
| 49818-AF | pusher     | 10,2  |



SS

**Pineapple coring tool**  
Svuota ananas  
Ananasausstecher  
Vide ananas  
Saca corazón de piña

| art.     | Ø cm. | l. cm. |
|----------|-------|--------|
| 48280-10 | 2,5   | 24     |



SS

**Pineapple slicer**  
 Taglia ananas  
 Ananasteiler  
 Coupe-ananas en rondelle  
 Cortador de piña en rondajas

| art.     | Ø cm. | l. cm. |
|----------|-------|--------|
| 48218-00 | 2,5   | 24     |



**Electric peeler**  
 Pelatrice elettrica  
 Elektr. Schälmachine  
 Eplucheur électrique  
 Pelador eléctrico

| art.     | cm.        | Kg. |
|----------|------------|-----|
| 49750-00 | 25x16x21,5 | 2   |



**Professional apple peeler**  
 Pela mele professionale  
 Profi-Apfelschäler  
 Pèle-pommes, professionnel  
 Pelador de manzanas, profesional

| art.     | cm.      | Kg. |
|----------|----------|-----|
| 49834-00 | 32x14x10 | 1,9 |



**Apple peeler with screw**  
 Pela mele con morsetto  
 Apfelschäler, Tischklemme  
 Pèle-pommes, socle serre-joint  
 Pelador de manzanas, fijación brida

| art.     | cm.      |
|----------|----------|
| 49835-00 | 30x10x17 |



**Apple peeler, vacuum-power base**  
 Pela mele con ventosa  
 Apfelschäler, Vakuum-Fuss  
 Pèle-pommes, socle vacuum  
 Pelador de manzanas, fijación ventosa

| art.     | cm.      |
|----------|----------|
| 49836-00 | 30x10x13 |



SS

**Apple corer/wedger**  
 Trancia spicchi per mela  
 Apfelentkerner-/Schneider  
 Lames évideur/coupe-pommes  
 Cortador y descorazonador manzanas

| art.     | Ø cm. |
|----------|-------|
| 48289-10 | 10    |



SS

**Egg wedger**  
 Taglia uova  
 Eierteiler  
 Tranche-oeufs  
 Cortahuevos

| art.     | Ø cm. | l. cm. |
|----------|-------|--------|
| 42597-00 | 6,5   | 21     |



SS

**Egg knocker**  
 Apriuovo  
 Eierköpfer  
 Toque oeuf  
 Abridor de huevos

| art.     | Ø cm. | l. cm. |
|----------|-------|--------|
| 42595-01 | 3,2   | 11     |



**Egg-slicer, aluminum**  
 Taglia uova, alluminio  
 Eierteiler, Aluminium  
 Tranche-oeufs rondelle, aluminium  
 Cortahuevos guitarra, aluminio

| art.     | cm.        |
|----------|------------|
| 42588-01 | 13,5x8x4,5 |



**Egg-slicer duo**  
 Taglia uova doppio  
 Eierteiler 2 in 1  
 Tranche-oeufs 2 emplacements  
 Cortahuevos doble

| art.     | cm.      |
|----------|----------|
| 42588-00 | 21x8x4,5 |



**Egg container**

Contentore per uova  
Eier-Behälter  
Porte-oeufs  
Contenedor para huevos

art. cm.  
47093-24 30x21,5x6,5



**AV**

**Egg container**

Contentore per uova  
Eier-Behälter  
Porte-oeufs  
Contenedor para huevos

art. cm.  
44947-07 15x20x5



**SS**

**Egg rings 2 pcs**

Anelli per uova 2 pz  
Eierringe, 2 Stk  
Ronds à oeufs, 2 pcs  
Anillos para huevos, 2 pz

art. Ø cm. h.  
42596-02 8 1,5



**Egg ring, non stick**

Anello per uova, antiaderente  
Eierring, beschichtet  
Rond à oeufs, anti-adhésif  
Anillo para huevos, antiadherente

art. Ø cm. h.  
42650-10 10 1,5



**Egg ring, non stick**

Anello per uova, antiaderente  
Eierring, beschichtet  
Rond à oeufs, anti-adhésif  
Anillo para huevos, antiadherente

art. Ø cm. h.  
42650-11 11 1,5



**Artichoke corer**

Svuota carciofi  
Artischocken Entkerner  
Etrogneur à artichauts  
Saca corazon para alcachofas

art. Ø cm. h.  
48288-02 8 8

**Top-rack dishwasher-safe. ABS body and scoop, PP cover, stainless steel blade.** – Lavabile in lavastoviglie nel cestello superiore. Corpo e paletta in ABS, coperchio in PP, lama inox.



**Brussel sprout cutter**

Taglia cavolini di Bruxelles  
Rosenkohl-Schneider  
Coupe-choux de Bruxelles  
Cortador de coles de Bruselas

art. cm.  
48288-03 8x8x10

**Dishwasher safe. SAN transparent body, ABS frame, PP base, stainless steel blade.** – Lavabile in lavastoviglie. Corpo trasparente SAN, telaio in ABS, base in PP, lama inox.



**SS**

**Mushroom cutter**

Taglia funghi  
Pilze-Teiler  
Tranche-champignons  
Cortador de hongos

art. Ø cm. l. cm.  
42598-00 7,6 20,7



**SS**

**Avocado peeler and slicer**

Pela/taglia avocado  
Avocadoschäler-/Teiler  
Pèle et tranche avocat  
Pelador y cortador de aguacete

art. l. cm.  
48286-62 18,5



**SS**

**Large vegetable slicer**

Pelaverdure  
Gemüseschäler  
Eplucheur à légumes  
Pelador de verduras

art. cm.  
48286-64 22x10



**Potato peeler**  
Pelapatate  
Sparschähler  
Eplucheur  
Pelador de patatas

| art.     | cm. |
|----------|-----|
| 42589-00 | 5x4 |



**Potato ricer with 3 discs**  
Schiacciapatate, 3 griglie  
Kartoffelpresse, 3 Roste  
Presse-purée, 3 grilles  
Pasapurés, 3 discos

| art.     | Ø cm. | cm.      |
|----------|-------|----------|
| 42566-03 | 8,5   | 30x10x11 |

**Discs/Dischi: ø 2,4 - 4,4 - 6,5 mm.**



**French fry cutter**  
Taglia patate  
Kartoffelschneidgerät  
Coupe-frites  
Cortador de patatas fritas

| art.     | cm.      | Kg. |
|----------|----------|-----|
| 49832-10 | 24x44x34 | 11  |

**Cutting knife/Quadro di taglio: 10 mm.**



**French fry cutter**  
Taglia patate  
Kartoffelschneidgerät  
Coupe-frites  
Cortador de patatas fritas

| art.     | cm.        |
|----------|------------|
| 49831-10 | 28x11x16,5 |

**Functional and solid. With suction base. Space-saving size. Accurate cutting 10 mm. Easy to clean.** – Funzionale e solido. Base con ventose. Salvaspazio. Taglio preciso, 10 mm. Facile da pulire.



**French fry cutter**  
Taglia patate  
Kartoffelschneidgerät  
Coupe-frites  
Cortador de patatas fritas

| art.     | cm.       | Kg. |
|----------|-----------|-----|
| 49832-02 | 26x9x12,5 | 1,2 |

**Cutting knives/Quadri di taglio: 9x9 - 12x12 mm.**



**Herb scissors, 5 blades**  
Forbice per erbe, 5 lame  
Kräuterschere, 5 Klängen  
Ciseaux à herbes, 5 lames  
Tijeras hierbas, 5 cuchillas

| art.     | l. cm. |
|----------|--------|
| 18277-00 | 10     |



**Cheese rotary grater**  
Grattugia formaggio rotatoria  
Drehe-Käse-Raffel  
Frissette à fromage  
Ralladora giratoria para queso

| art.     | Ø cm. | h. |
|----------|-------|----|
| 48281-22 | 22    | 17 |

**Oak wood base.** – Base legno di quercia.



**Rotary grater cover**  
Cloche per grattugia rotatoria  
Käse-Raffel-Haube  
Cloche à frissette  
Tapa para ralladora

| art.     | Ø cm. | h. |
|----------|-------|----|
| 48281-23 | 15,5  | 11 |



**Tortillas wedger**  
Taglia tortillas  
Tortillasteiler  
Coupe-tortillas  
Corta tortillas

| art.     | Ø cm. |
|----------|-------|
| 42599-06 | 25    |
| 42599-08 | 25    |

**Wedges/Spicchi: 6 - 8.**





**Grater, automatic**  
Grattugia automatica  
Reibe, automatisch  
Râpe automatique  
Rallador automático

art. cm.  
48295-10 20x5,4

**Hermetic container, removable, with lid, 2 blades.**  
**Ideal for cheese, nuts, chocolate, etc.**  
Recipiente ermetico, removibile, con cop., 2 lame.  
Ideale per formaggio, noci, cioccolato, ecc.



**Cheese wire cutter**  
Lira per formaggi  
Käse Drahtschneider  
Lyre à fromage  
Lira para quesos

art. cm.  
48282-21 20,5x26,7



**Garlic press, chromed**  
Spremiaglio, cromato  
Knoblauchpresse, verchromt  
Presse-ail, chromé  
Prensador de ajo, cromado

art. cm. l. cm.  
42565-00 3,5x2,5 14,5



**Olive seed remover, chromed**  
Snocciolatore, cromato  
Olivenentsteiner, verchromt  
Dénoyoteur, chromé  
Quita pepa/hueso, cromado

art. l. cm.  
42563-00 17



**Cherry core stripper**  
Snocciolatore  
Kirschenentsteiner  
Dénoyoteur de cerises  
Quita pepa/hueso

art. Ø cm. h.  
42563-44 10 34



**Mandoline**  
Mandolino  
Gemüseobel Mandoline  
Mandoline  
Mandolina

art. cm. Kg.  
49829-11 39x12,5x5,5 1,7

**Equipped with 7 interchangeable blades.**  
Dotato di 7 lame intercambiabili.





**Slicer Mandoline, Grand Gourmet**

Mandolino Grand Gourmet  
Gemüsehobel Grand Gourmet  
Mandoline Grand Gourmet  
Mandolina Grand Gourmet

| art.     | cm.      | Kg. |
|----------|----------|-----|
| 49830-60 | 40x12x28 | 1,6 |

**38 blades, 10 mm. – 38 lame, 10 mm.**



**Mandoline**

Mandolino  
Mandolino  
Gemüsehobel Mandoline  
Mandoline  
Mandolina

| art.     | cm.       | Kg. |
|----------|-----------|-----|
| 49755-10 | 38x11x3,5 | 1   |

**Non-slip base, ergonomic handle. Adjustable and precise cutting thickness. – Base antiscivolo, impugnatura ergonomica. Spessore di taglio regolabile e preciso.**



**Mandoline**

Mandolino  
Mandolino  
Gemüsehobel Mandoline  
Mandoline  
Mandolina

| art.     | cm.         | Kg. |
|----------|-------------|-----|
| 49752-00 | 33,5x11x2,3 | 0,6 |

**3 interchangeable blades of 2-3-6 mm. 3 lame intercambiabili da 2-3-6 mm.**



**Japanese Mandoline slicer**

Mandolino giapponese  
Japanese Gemüsehobel  
Mandoline japonaise  
Mandolina japonés

| art.     | cm.       | Kg. |
|----------|-----------|-----|
| 49753-06 | 11x31,5x3 | 0,3 |
| 49753-09 | 15x35x3,3 | 0,5 |

**1 plain blade and 3 blades of 1-2-3 mm. 1 lama liscia e 3 lame da 1-2-3 mm.**



**Cutter/corer**

Intaglia verdure  
Ausstechforme  
Découpoir  
Sacabocados

| art.     | cm.       |
|----------|-----------|
| 48286-70 | 3,7x8,5x9 |

**Cutting ø 3,4 cm. – Taglio ø 3,4 cm.**



**Spiral vegetable slicer 3-blade**

Taglia verdure 3-lame  
Gemüeschneider 3-Messer  
Coupe légumes 3 lames  
Cortador de verduras 3 cuchillas

| art.     | cm.      |
|----------|----------|
| 49827-99 | 30x14x22 |

**3 interchangeable s/s blades (3 - 6 mm. and 1 straight blade for ribbon cuts). 3 lame inox intercambiabili (3 - 6 mm. e 1 lama dritta per taglio a nastro).**



**Spiral vegetable slicer 7-blades 8-cuts**

Taglia verdure 7-lame 8-tagli  
Gemüeschneider 7-Messer 8-Schnitte  
Coupe légumes 7-lames 8-coupes  
Cortador de verduras 7-cuchillas 8-cortes

| art.     | cm.            |
|----------|----------------|
| 49827-77 | 14,3x23,8x14,3 |

**Includes: 4 mm straight blade, 10 mm chipper blade, 1,5 mm wavy blade, 2,5 mm straight blade, 2 mm Angel hair blade, 3 mm shredder blade, 6 mm chipper blade. Top-rack dishwasher-safe. Include 2 lame lisce mm 2,5 e 4, lama ondulata da 1,5 mm, lama capelli d'angelo da 2 mm, 3 lame taglio spaghetti mm. 3, 6 e 10. Lavabile in lavastoviglie nel cestello superiore.**



**Strip slicer**

Taglia verdure  
Gemüeschneider  
Coupe-lanières  
Cortador de verduras japonés

| art.     | cm.      | Kg. |
|----------|----------|-----|
| 49823-00 | 20x20x25 | 1,9 |

**Width of cut 15 cm. Max vegetables length 11 cm. and ø 17 cm. – Larghezza taglio 15 cm. Lunghezza max verdura 11 cm. e ø 17 cm.**



ABS

**Strip slicer**  
Taglia verdure  
Gemüseschneider  
Coupe lanière  
Cortador de verduras

art. cm.

49823-89 28x25x16,5

**Width of cut 13 cm. Thickness 0,5 mm.**  
Larghezza taglio 13 cm. Spessore 0,5 mm.



ABS

**Strip & spaghetti slicer**  
Taglia verdure  
Gemüseschneider  
Coupe lanière et spaghetti  
Cortador de verduras japonés

art. cm.

49823-99 28x25x16,5

**Width of cut 13 cm. 2 blades 130x0,5 - 1x1,2 mm.**  
Larghezza taglio 13 cm. 2 lame 130x0,5 - 1x1,2 mm.



ABS

SS

**Vegetable cutter LE ROUET GOURMET**  
Taglia verdure  
Gemüseschneider  
Coupe légumes  
Cortador de verduras

art. cm. Kg.

49827-03 13,5x36x24,3 2,4

**Cutting blocks 1-2-4 mm. Cutting thickness blade guirlandes 1>4 mm.**  
Spessore taglio lama guirlandes 1>4 mm.



SS

**Decoration tools 18 pcs**  
Attrezzi decoro, 18 pz  
Dekoriersatz, 18-Tlg.  
Outils de décor 18 pcs  
Herramientas decoración 18 pz

art.

48286-03



SS

**Decoration tools 22 pcs**  
Attrezzi decoro, 22 pezzi  
Dekoriersatz, 22-Tlg.  
Outils de décor 22 pcs  
Herramientas decoración 22 pz

art. cm.

48286-13 38,5x29



SS

**Thaï knife**  
Stiletto thailandese  
Thaï-Messer  
Stylet thaï  
Cuchillo thaï

art. l. cm.

48286-08 16



**Ice knife**

Coltello ghiaccio  
Eis-Messer  
Couteau à glace  
Cuchillo para hielo

| art.     | l. cm.  | gr. |
|----------|---------|-----|
| 47885-01 | 14+10,5 | 200 |



**Chisel V shape**

Scalpello ghiaccio a V  
Eismeissel  
Ciseau à glace  
Cinsel a V para hielo

| art.     | l. cm. | gr. |
|----------|--------|-----|
| 47885-02 | 31,5   | 200 |



**Chisel flat medium**

Scalpello ghiaccio 3 lati smussati  
Eismeissel  
Ciseau à glace  
Cinsel para hielo

| art.     | l. cm. | gr. |
|----------|--------|-----|
| 47885-03 | 50     | 600 |



**Chisel flat big**

Scalpello ghiaccio 1 lato smussato  
Eismeissel  
Ciseau à glace  
Cinsel para hielo

| art.     | l. cm. | gr. |
|----------|--------|-----|
| 47885-04 | 74,5   | 820 |



**Ice chisel set 4 pcs**

Scapelli ghiaccio 4 pz  
Eismeissel 4 Stk  
Ciseaux à glace 4 pcs  
Cinseles para hielo 4 piezas

| art.     | Kg.  |
|----------|------|
| 47885-05 | 1,93 |



**Butter churn**

Mantecatore per burro  
Butterfaß  
Baratte à beurre  
Mantequera

| art.     | cm.          | lt. |
|----------|--------------|-----|
| 48294-01 | 11,5x11,5x40 | 1,6 |



**Butter mold**

Stampo per burro  
Butterform  
Moule à beurre  
Molde para mantequilla

| art.     | cm.          | gr. |
|----------|--------------|-----|
| 48294-02 | 12,2x6,6x4,3 | 80  |
| 48294-03 | 15,8x9x5     | 125 |



**Butter mold**

Stampo per burro  
Butterform  
Moule à beurre  
Molde para mantequilla

| art.     | cm.        | gr. |
|----------|------------|-----|
| 48294-04 | 21x9,4x5,8 | 250 |





**Grater, non-slip handle**  
Grattugia, manico antiscivolo  
Reibe, Rutschfestes Griff  
Râpe queue antidérapant  
Rallador mango antiderrapante

art. cm. l. cm.  
42560-01 4x22 38,5



**Grater, non-slip handle**  
Grattugia, manico antiscivolo  
Reibe, Rutschfestes Griff  
Râpe queue antidérapant  
Rallador mango antiderrapante

art. cm. l. cm.  
42560-02 4x22 38,5



**Grater, non-slip handle**  
Grattugia, manico antiscivolo  
Reibe, Rutschfestes Griff  
Râpe queue antidérapant  
Rallador mango antiderrapante

art. cm. l. cm.  
42560-03 4x22 38,5



**Grater, non-slip handle**  
Grattugia, manico antiscivolo  
Reibe, Rutschfestes Griff  
Râpe queue antidérapant  
Rallador mango antiderrapante

art. cm. l. cm.  
42560-04 7,7x13,3 30



**Grater, non-slip handle**  
Grattugia, manico antiscivolo  
Reibe, Rutschfestes Griff  
Râpe queue antidérapant  
Rallador mango antiderrapante

art. cm. l. cm.  
42560-05 7,7x13,3 30



**Grater, non-slip handle**  
Grattugia, manico antiscivolo  
Reibe, Rutschfestes Griff  
Râpe queue antidérapant  
Rallador mango antiderrapante

art. cm. l. cm.  
42560-06 7,7x13,3 30



**Grater, non-slip handle**  
Grattugia, manico antiscivolo  
Reibe, Rutschfestes Griff  
Râpe queue antidérapant  
Rallador mango antiderrapante

art. cm. l. cm.  
42560-07 7,7x13,3 30



**Grater, non-slip handle**  
Grattugia, manico antiscivolo  
Reibe, Rutschfestes Griff  
Râpe queue antidérapant  
Rallador mango antiderrapante

art. cm. l. cm.  
42560-08 7,7x13,3 30



**Grater, non-slip handle**  
Grattugia, manico antiscivolo  
Reibe, Rutschfestes Griff  
Râpe queue antidérapant  
Rallador mango antiderrapante

art. cm. l. cm.  
42560-09 7,7x13,3 30



SS

**Spatzle sieve**  
Grattugia per spatzle  
Spätzle-Reibe  
Grille à spatzle  
Rallador para spatzle

art. cm.  
49844-01 31x10,5x6



SS

**Nutmeg grater**  
Grattugia noce moscata  
Muskatreibe  
Râpe à muscade  
Rallador nuez moscada

art. cm.  
42556-00 4,5x14



SS

**4-ways grater**  
Grattugia 4 tagli  
Vierkantreibe  
Râpe 4 faces  
Rallador 4 caras

art. cm.  
42569-04 10x8x23



PP

**Dumplin maker**  
Stampo panzerotti  
Knödel-Form  
Moule à chaussons  
Molde para empanadillas

art. mm.  
49843-05 62, 82, 104, 177



**Safety can opener**  
Apriscatole sicuro  
Sicherheitsdosenöffner  
Ouvre-boîte de sûreté  
Abrelatas de seguridad

art. cm.  
48222-01 12,5x8



**Universal can opener**  
Apriscatole universale, nichelato  
Universal-Dosenöffner  
Ouvre-boîte, universel  
Abrelatas universal

art. cm.  
48220-00 8x7



**Can opener, PP handle**  
Apriscatole, impugnatura PP  
Dosenöffner, Griffe aus PP  
Ouvre-boîte, poignées PP  
Abrelatas, mango PP

art. l. cm.  
48280-03 21



SS

**Electric sieve**  
Passaverdura elettrico  
Elektropassiergerät  
Moulin électrique  
Molino eléctrico

art. Ø cm. h. kg./H Kg.  
49879-37 37 108 300 23,5

Equipped with 3 mm disc. – Griglia 3 mm.



**Sieve on tripod, tinned**

Passaverdura stagnato con supporto  
Passiergerät, verzinkt, mit Träger  
Moulin étamé sur pied  
Molino estañado sobre pie

| art.     | Ø cm. | h. | Kg. |
|----------|-------|----|-----|
| 42577-39 | 39    | 80 | 14  |

**Equipped with 3 mm disc. – Griglia 3 mm.**



**Tomato juicer sieve**

Passapomodoro professionale  
Profi-Tomatenpassiergerät  
Moulin à tomates professionnel  
Molino para tomates, profesional

| art.     | Ø cm. | h. |
|----------|-------|----|
| 42576-00 | 21    | 50 |

**Equipped with 1 mm disc. – Griglia 1 mm.**



**Herb mill**

Macinaerbe  
Kräutermühle  
Moulin fines herbes  
Molino de hierbas finas

| art.     | cm.  |
|----------|------|
| 42558-00 | 7x22 |

SS



SS

**Sieve, 3 discs**

Passaverdura, 3 griglie  
Passiergerät, 3 Roste  
Moulin inox, 3 grilles  
Molino inox, 3 rejillas

| art.     | Ø cm. | h.   | Kg.  |
|----------|-------|------|------|
| 42571-20 | 19    | 16,5 | 0,46 |
| 42572-24 | 24    | 16,5 | 0,82 |

**Discs: 1,5 - 2 - 4 mm. – Griglie: 1,5 - 2 - 4 mm.**



SS

**Sieve, 3 discs**

Passaverdura, 3 griglie  
Passiergerät, 3 Roste  
Moulin inox, 3 grilles  
Molino inox, 3 rejillas

| art.     | Ø cm. | h. | Kg. |
|----------|-------|----|-----|
| 42570-32 | 31    | 25 | 1,4 |

**Discs: 1,5 - 2,5 - 4 mm. – Griglie: 1,5 - 2,5 - 4 mm.**



**Sieve, tinned, 3 discs**

Passaverdura stagnato, 3 griglie  
Passiergerät, verzinkt, 3 Roste  
Moulin étamé, 3 grilles  
Molino estañado, 3 rejillas

| art.     | Ø cm. | h. | Kg. |
|----------|-------|----|-----|
| 42573-31 | 31    | 25 | 1,4 |

**Discs: 1,5 - 2,5 - 4 mm. – Griglie: 1,5 - 2,5 - 4 mm.**



SS

**Sieve, 1 disc**

Passaverdura, 1 griglia  
Passiergerät, 1 Rost  
Moulin inox, 1 grille  
Molino inox, 1 rejilla

| art.     | Ø cm. | h. | Kg. |
|----------|-------|----|-----|
| 42574-37 | 37    | 32 | 3,5 |

**Equipped with 3 mm disc. – Griglia 3 mm.**



**Sieve, tinned, 1 disc**

Passaverdura stagnato, 1 griglia  
Passiergerät, verzinkt, 1 Rost  
Moulin étamé, 1 grille  
Molino estañado, 1 rejilla

| art.     | Ø cm. | h. | Kg. |
|----------|-------|----|-----|
| 42575-37 | 37    | 32 | 3,5 |

**Equipped with 3 mm disc. – Griglia 3 mm.**



42570 - 42573



42574 - 42575  
42577 - 49879



SS

**Bottles and cans press**

Pressa bottiglie e lattine  
Flaschen und Dosen Presse  
Presse bouteilles et boîtes  
Prensa botellas y latas

art. cm.  
49815-00 13,5x12x50

**To crush cans and plastic bottles. All cans. Bottles up to 2.5 l.** – Per tutti i tipi di lattine e per bottiglie di plastica fino a 2,5 l.



SS

**Table top can opener**

Apriscatole da banco  
Tisch-Dosenöffner  
Ouvre-boîte  
Abrelatas

art. cm. Kg.  
49867-01 28x12,2x77,5 5

**With screw base. Patented opening system. Opens round cans any sizes securely from 8 to 50 cm height), leaves smooth and not sharp edges. The cap can be reused. Dishwasher safe.**  
Base da avvitare. Sistema di apertura brevettato. Per scatole rotonde di tutte le dimensioni (h da 8 a 50 cm). Rifilo netto dei bordi esterni. Nessun rischio di taglio. Possibilità di riutilizzare il coperchio dalla scatola. Lavabile in lavastoviglie.



SS

**Table top can opener**

Apriscatole da banco  
Tisch-Dosenöffner  
Ouvre-boîte  
Abrelatas

art. cm. Kg.  
49867-02 28x12,2x77,5 5

**With clamp base. Patented opening system. Opens round cans any sizes securely from 8 to 50 cm height), leaves smooth and not sharp edges. The cap can be reused. Dishwasher safe.**  
Base con morsetto. Sistema di apertura brevettato. Per scatole rotonde di tutte le dimensioni (h da 8 a 50 cm). Rifilo netto dei bordi esterni. Nessun rischio di taglio. Possibilità di riutilizzare il coperchio dalla scatola. Lavabile in lavastoviglie.



**Table top can opener**

Apriscatole da banco  
Tisch-Dosenöffner  
Ouvre-boîte  
Abrelatas

art. l. cm.  
19810-00 56

**Can size up to height 45 cm. Clamp base and bar in die-cast aluminum, steel head. Table fixing either with screws or clamp.** – Altezza scatola fino a 45 cm. Corpo in alluminio pressofuso, testa in acciaio, fissaggio a viti o morsetto.



**Table top can opener, steel**

Apriscatole da banco, acciaio  
Tisch-Dosenöffner, Stahl  
Ouvre-boîte, acier  
Abrelatas, acero

art. l. cm.  
49811-00 40

**Can size up to height 30 cm. Table fixing with clamp base.** – Altezza scatola fino a 30 cm. Fissaggio a morsetto.



SS

**Table top can opener**

Apriscatole da banco  
Tisch-Dosenöffner  
Ouvre-boîte  
Abrelatas

art. l. cm.  
49812-00 55

**Can size up to height 40 cm. Table fixing with clamp base.** – Altezza scatola fino a 40 cm. Fissaggio a morsetto.



SS

**Electric can opener**

Apriscatole elettrico  
Elektrodosenöffner  
Ouvre-boîte électrique  
Abrelatas eléctrico

art. cm. Kg.  
49814-00 44x25x75 13

**Dual speed motor. Opens all can shapes from 50 to 270 mm height.** – Motore a 2 velocità. Per tutti i formati di scatola da 50 a 270 mm di altezza.



# THERMOMETERS TERMOMETRI

KITCHEN UTENSILS  
UTENSILI DA CUCINA





SS

**Meat roasting thermometer**

Termometro arrosti  
Braten-Thermometer  
Thermomètre à rôtir  
Termómetro asado

art. Ø cm. scala range  
49705-00 4,5 1°C 0+120°C

Penetration probe 13 cm. – Sonda l. 13 cm.



SS

**Meat roasting thermometer**

Termometro arrosti  
Braten-Thermometer  
Thermomètre à rôtir  
Termómetro asado

art. Ø cm. range  
19705-00 5 +54+88°C



SS

**Cooking & frying thermometer**

Termometro fritti  
Back-Thermometer  
Thermomètre à friture  
Termómetro frituras

art. Ø cm. scala range  
19706-00 5 10°C +38+205°C

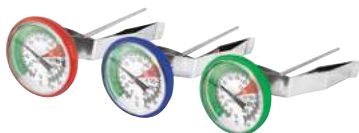

SS

**Milk frothing thermometers, 3 pcs**

Termometri latte/barista, 3 pz  
Mich-Thermometer, 3 Stk  
Thermomètres à lait, 3 pièces  
Termómetros leche, 3 pz

art. Ø cm. scala range  
49709-03 4,5 1°C -10+110°C

Red, green and blue, to easily identify different types of milk used, to avoid cross-contamination.

Stem 175 mm. – Rosso, verde e blu, per identificare facilmente i diversi tipi di latte utilizzati, per evitare la contaminazione incrociata. Stelo 175 mm.



**Sugar thermometer**

Termometro per zucchero  
Zuckerthermometer  
Thermomètre à sucre  
Termómetro azúcar

art. l. cm. scala range  
47843-00 30 1°C +80+200°C

Stainless steel housing. – Guaina inox.



**Sugar/jam thermometer**

Termometro per zucchero/marmellata  
Zucker- und Marmeladenthermometer  
Thermomètre à sucre et confiture  
Termómetro azúcar y mermelada

art. scala range  
47843-05 2°C +40+200°C

Brass. – Ottone. Dim. 4,7x20 cm.



**Baker's thermometer**

Termometro per panettiere  
Bäckerthermometer  
Thermomètre boulager  
Termómetro panadero

art. l. cm. scala range  
49712-00 30 1°C -10+60°C

Plastic housing. – Guaina plastica.



SS

**Oven thermometer**

Termometro per forno  
Ofenthermometer  
Thermomètre à four  
Termómetro horno

art. Ø cm. scala range  
19709-00 7 10°C +38+316°C



ABS

**Fridge/freezer thermometer**

Termometro frigo/freezer  
Kühlschrank-Thermometer  
Thermomètre à réfrigérateur  
Termómetro congelador

art. Ø cm. scala range  
49885-02 7 1°C -50+50°C



SS

**Fridge/freezer thermometer**

Termometro frigo/freezer  
Kühlschrank-Thermometer  
Thermomètre à réfrigérateur  
Termómetro congelador

art. Ø cm. scala range  
19702-00 6 1°C -29+27°C



ABS

**Digital thermometer**

Termometro digitale  
Digitalthermometer  
Thermomètre digitale  
Termómetro digital

art. scala range  
49887-00 0,1°C -50+70°C

Dim. cm. 1,5x5x7



**Digital fridge thermometer**

Termometro digitale per frigorifero  
Kühlschrank-Digitalthermometer  
Thermomètre digitale à réfrigérateur  
Termómetro digital para refrigerador

art. scala range  
49887-02 0,1°C -9,9+49,9°C

**Dim. Cm. 2,6x4,5x7,3. Water resistant IP65. Features a food safety zone icon in the display that indicates when the temperature is outside the range of 0 to 5°C. – Resistente all'acqua IP65. Un'icona indica sul display quando la temperatura è al di fuori dell'intervallo da 0 a 5°C.**

**ABS**



**Room/wall thermometer**

Termometro da muro  
Wandthermometer  
Thermomètre à mur  
Termómetro de pared

art. scala range  
49702-00 1°C -30+50°C

**Dim. cm. 20,5x4. Without mercury. – Senza mercurio.**



**Pocket thermometer**

Termometro da tasca  
Taschenthermometer  
Thermomètre à poche  
Termómetro digital

art. l. cm. scala range  
19701-00 15 0,1°C -50+150°C



**Digital thermometer**

Termometro digitale  
Digitalthermometer  
Thermomètre digitale  
Termómetro digital

art. scala range  
49710-00 1°C -50+300°C

**IP 65. Probe 135 mm. ø 2,5 mm. Sonda 135 mm. ø 2,5 mm.**



**Pocket thermometer**

Termometro da tasca  
Taschenthermometer  
Thermomètre à poche  
Termómetro digital

art. scala range  
49701-00 0,1°C -50+200°C

**Probe 125 mm. ø 3,5 mm. Sonda 125 mm. ø 3,5 mm.**



**Digital thermometer**

Termometro digitale  
Elektronisches Thermometer  
Thermomètre digital  
Termómetro digital

art. scala range  
49715-00 0,1°C -50+300°C

**Probe 125 mm. ø 3,5 mm. Sonda 125 mm. ø 3,5 mm.**



**Digital thermometer**

Termometro digitale  
Elektronisches Thermometer  
Thermomètre digital  
Termómetro digital

art. scala range  
49716-00 0,1°C -50+300°C

**Dim. cm. 1,9x7x15,2. Countdown/up 99h-59m.**



**Digital thermometer**

Termometro digitale  
Elektronisches Thermometer  
Thermomètre digital  
Termómetro digital

art. scala range  
49883-00 0,1°C -50+300°C

**Dim. cm. 13x5,5x2,5. Probe 13 cm. ABS case incl. Biomaster AT. – Involucro ABS con Biomaster. Sonda 13 cm.**





**Multi-function thermometer**

Termometro multifunzione  
Multifunktions-Thermometer  
Thermomètre multifonction  
Termómetro multifunción

art. scala range  
49988-00 0,1°C -19,9+149,9°C

**Dim. cm. 2,5x7,3x12,3. Probe 125 mm. ø 3,5.**  
**Housing & probe handle incl. Biomaster AT.**  
Involucro e manico sonda con Biomaster. Sonda  
125 mm. ø 3,5.



**Infrared thermometer**

Termometro a infrarossi  
Infrarot-Thermometer  
Thermomètre infrarouge  
Termómetro infrarrojo

art. scala range  
49986-00 0,1°C -49,9+349,9°C

**Dim. cm. 2,5x5,2x10**



**Infrared thermometer**

Termometro a infrarossi  
Infrarot-Thermometer  
Thermomètre infrarouge  
Termómetro infrarrojo

art. scala  
49884-08 0,1/1°C

**Dim. cm. 4x6,6x15,5. Range infrared-Infrarossi:  
-60 to 500°C – Range probe-Sonda: -64 to 1370°C.**



**Infrared thermometer**

Termometro a infrarossi  
Infrarot-Thermometer  
Thermomètre infrarouge  
Termómetro infrarrojo

art. scala range  
49717-00 1°C -50+400°C

**Dim. cm. 17,5x4x7,2**



**Infrared thermometer**

Termometro a infrarossi  
Infrarot-Thermometer  
Thermomètre infrarouge  
Termómetro infrarrojo

art. scala range  
49987-00 0,1°C -50+330°C

**Dim. cm. 3,6x8,8x13,1**



**Waterproof thermometer**

Termometro waterproof  
Waterproof-Thermometer  
Thermomètre waterproof  
Termómetro waterproof

art. scala range  
49711-00 0,1°C -50+300°C

**Dim. Ø 51x178 mm. Waterproof IP66. Auto-  
rotating display. S/steel penetration probe Ø  
2,5x70 mm stainless steel, Ø 1,6 mm tip.**  
Impermeabile IP66. Display a rotazione automatica.  
Sonda di penetrazione inox Ø 2,5x70 mm., punta  
Ø 1,6 mm.



**Spatula with thermometer**

Spatola con termometro  
Rührspaten mit Thermometer  
Spatule avec thermomètre  
Espátula con termómetro

art. range  
49729-00 -50+300°C

**Dim. cm. 26x4x1,8**







**Digital thermometer**

Termometro digitale  
Elektronisches Thermometer  
Thermomètre digital  
Termómetro digital

| art.     | scala   | range         | col. |
|----------|---------|---------------|------|
| 49880-10 | 0,1/1°C | -49,9+299,9°C | ●    |
| 49880-11 | 0,1/1°C | -49,9+299,9°C | ●    |
| 49880-12 | 0,1/1°C | -49,9+299,9°C | ●    |

Dim. cm. 1,9x5x15,7. IP66/67. S/steel probe Ø 3,3 x 115 mm. folds back through 180°.



**Digital thermometer**

Termometro digitale  
Elektronisches Thermometer  
Thermomètre digital  
Termómetro digital

| art.     | scala   | range         | col. |
|----------|---------|---------------|------|
| 49880-13 | 0,1/1°C | -49,9+299,9°C | ●    |
| 49880-14 | 0,1/1°C | -49,9+299,9°C | ●    |
| 49880-15 | 0,1/1°C | -49,9+299,9°C | ○    |

Sonda inox ø 3,3 x 115 mm. pieghevole a 180°.



**Digital thermometer**

Termometro digitale  
Elektronisches Thermometer  
Thermomètre digital  
Termómetro digital

| art.     | scala   | range         | col. |
|----------|---------|---------------|------|
| 49880-17 | 0,1/1°C | -49,9+299,9°C | ●    |

Dim. cm. 1,9x5x15,7. IP66/67. S/steel probe Ø 3,3 x 115 mm. folds back through 180°. IP66/67. Sonda inox ø 3,3 x 115 mm. pieghevole a 180°.



**Sous vide cooking thermometer**

Termometro per sottovuoto  
Vakuum-Koch-Thermometer  
Thermomètre pour cuisson sous-vide  
Termómetro cocción al vacío

| art.     | scala | range                            |
|----------|-------|----------------------------------|
| 49881-01 | 0,1°C | -99,9+299,9°C<br>1°C +300+1372°C |

Kit: thermometer, Sous-Vide needle probe 60 mm., one metre foam/tape, zip pouch, free traceable certificate of calibration.

Kit: termometro, sonda per sottovuoto 60 mm., 1 metro di nastro adesivo, astuccio con zip, certificato di calibrazione tracciabile.



**Sous vide cooking thermometer**

Termometro per sottovuoto  
Vakuum-Koch-Thermometer  
Thermomètre pour cuisson sous-vide  
Termómetro cocción al vacío

| art.     | scala | range         |
|----------|-------|---------------|
| 49881-11 | 0,1°C | -49,9+299,9°C |

Dim. 1,9x4,7x15,3 cm. S/steel needle probe Ø 1,1 x 60 mm. FREE traceable certificate of calibration incl. – Sonda ad ago inox Ø 1,1 x 60 mm. Certificado di calibrazione incl.



**Sous vide foam tape**

Nastro adesivo per sottovuoto  
Vakuumschaumklebeband  
Ruban adhésif pour sous-vide  
Cinta adhesiva para cocción al vacío

| art.     | l. cm. |
|----------|--------|
| 49881-99 | 100    |

Used in conjunction with thermometer to measure the core temperature without suffering water ingress into vacuum sealed bag.

Utilizzato in combinazione con il termometro evita che penetri acqua nel sacchetto sotto vuoto.



**Digital oven thermometer**

Termometro digitale da forno  
Ofen-Digitalthermometer  
Thermomètre à four digital  
Termómetro horno digital

| art.     | Ø cm. | scala | range     |
|----------|-------|-------|-----------|
| 49719-00 | 8     | 1°C/F | -50+300°C |

Loud 70dB audible temperature alarm. 114 mm probe with 1,2 metre s/s braided lead that allows the probe to remain in the food during cooking. Water/dust resistance: IP65 protection.

Allarme acustico 70dB. Sonda 114 mm., cavo inox 1,2 metri che permette l'utilizzo durante la cottura. Resistenza acqua/polvere. IP65.



**Waterproof digital timer**

Timer digitale a tenuta stagna  
Wasserdichte Digitaltimer  
Timer digital étanche  
Reloj digital impermeable

| art.     | Ø cm. | h. |
|----------|-------|----|
| 49733-00 | 8     | 17 |

IP 65. 99M-99S. Dust and flour proof. Sound and flashing alarms. Hanging hook and suction cup. – A prova di polvere e farina. Suono e allarme lampeggiante. Gancio e ventosa.



**Digital timer**

Timer digitale  
Digitalkochalarm  
Minuterie digitale  
Reloj digital

art. cm.  
49720-00 7x5,5

**Timer 23H-59M-59S. Clock 12H AM/PM. Count down. 80dB audible alarm. Magnetic pad.**

Orologio 12H AM/PM. Cronometro. Allarme acustico 80dB. Attacco magnetico.



**Digital timer**

Timer digitale  
Digitalkochalarm  
Minuterie digitale  
Reloj digital

art. cm.  
49734-00 9x4,7x4,5

**Count-down/up: 23H 59M 59S. 80 dB sound. 1 AAA battery.**



**Digital timer jumbo**

Timer digitale gigante  
Digitalkochalarm jumbo  
Minuterie digitale géante  
Reloj digital gigante

art. cm.  
49735-00 13,5x9,5x16

**80dB sound. 4 programs. Electrical plug & battery. Waterproof front panel IP54.**

Presse elettrica e batteria. Pannello frontale impermeabile IP54.



ABS

**Thermohygrometer with clock**

Termoigrometro con orologio  
Thermohygrometer mit Uhr  
Thermohygromètre avec horloge  
Termohigrómetro con reloj

art. cm. range  
49721-03 13x10x2,5 -20+50°C

**10-99% RH - 12/24 H.**



**Syrup hydrometer**

Densimetro per sciroppo  
Sirup-Hydrometer  
Hydromètre à sirop  
Hidrómetro de jarabe

art. l. cm.  
49703-00 12,5

**1100-1400 g/m - 15-40°Bé**



**Hydrometer for brine and salt**

Densimetro per salamoia e sale  
Hydrometer für Sole und Salz  
Hydromètre à saumure et sel  
Hidrómetro de salmuera y sal

art. l. cm.  
49730-20 19,5

**1000-1250 g/m - 0-30°Bé**



ABS

PP

**Salt tester and thermometer**

Salinometro e termometro  
Salzgehalt-Meter u. Thermometer  
Testeur de salinité et thermometer  
Salinometro y termómetro

art. cm.  
49730-00 3,2x1,6x22,5

**To measure the salt content of food and liquids in percentage from 0 to 5%. Temperature from 0°+100°C. – Per misurare il tenore di sale in alimenti e liquidi in percentuale da 0 a 5%. Temperatura da 0°+100° C.**



**Frying oil test strips**

Strisce reattive per oli di frittura  
Bratöl-Teststreifen  
Bandes réactives pour les huiles de friture  
Tiras reactivas para control aceites

art.  
49731-99

**Storage bottles of 100 Oil Quality Test Strips and easy to read colour chart. Hold the test strip in the oil for 2 seconds (max 40°C), then remove it and wait 2 minutes, next, compare the strip to the colour chart. – Flacone con 100 strisce reattive e tabella colori di facile lettura. Immergere la fascia colorata della striscia nell'olio (max. 40°C) per 2 secondi, quindi rimuoverla e attendere 2 minuti. Confrontare la striscia con la tabella colori.**





ABS

SS

**Frying oil tester & thermometer**

Tester e termometro per oli di frittura  
Bratöltester und Thermometer

Testeur et thermomètre des huiles de friture  
Medidor y termómetro para aceites

art. scala range  
49723-00 0,1°C +30+200°C

**Dim. 3,1x4,8x36,5 cm. Suitable for measuring olive oil, palm oil, rapeseed oil, peanut oil, soybean oil, sesame oil, vegetable oils and animal fats. IP65.** – Adatto per misurare olio di oliva, palma, colza, arachidi, soia, sesamo, oli vegetali e grassi animali. IP65.



**Frying oil tester**

Test degradazione oli di frittura  
Kontrollsystem für Bratenöle  
Test dégradation des huiles de friture  
Test para control aceites

art.  
49731-10

**Consisting of two reagents that are not harmful to health and environmentally friendly. For 20 tests. ATTENTION: works with all types and brands of frying oil, (except with palm oil).** – Composto da due reagenti non nocivi per la salute e rispettosi dell'ambiente. Per 20 test. ATTENZIONE: funziona con tutti i tipi e le marche di olio di frittura, (tranne che con l'olio di palma).



- 😊 **NEW OIL <9% of polar compounds**  
OLIO NUOVO <9% di composti polari
- 😊 **GOOD OIL from 10 to 16% of polar compounds**  
OLIO BUONO da 10 a 16% di composti polari
- 😐 **DETERIORATED OIL from 17 to 23% of polar compounds**  
OLIO DETERIORATO da 17 a 23% di composti polari
- 😞 **OIL TO CHANGE >24% of polar compounds**  
OLIO DA CAMBIARE >24% di composti polari



**Labels solvable**

Etichette dissolvibili  
Lösbare Etiketten  
Etiquettes solubles  
Etiquetas solubles

art. cm. pcs/pz  
44630-01 7,5x4 250

**Dissolvable in less than 20 seconds. Suitable for any type of surface.** – Dissolvibili in meno di 20 secondi. Adatte a qualsiasi tipo di superficie.



**Labels 14 allergens**

Etichette 14 allergeni  
Etiketten 14 Allergene  
Etiquettes 14 allergènes  
Etiquetas 14 alergenos

art. cm. pcs/pz  
44630-02 7,5x4 500

**Labels with all 14 allergens pre-printed.**  
Etichette con i 14 allergeni prestampati.



**Labels Express 7 days**

Etichette express 7 giorni  
Etiketten Express 7 Tage  
Etiquettes express 7 jours  
Etiquetas express 7 días

art. cm. pcs/pz  
44630-03 3x2,5 1750

**Different colors based on the day of the week. Data to be written: product description; date of production or expiry date.** – Diversi colori in base al giorno della settimana. Dati da inserire: descrizione del prodotto; data di produzione o data di scadenza.





**Labels frozen food**

Etichette frozen/surgelati  
Etiketten Tiefkühlkost  
Etiquettes aliments surgelés  
Etiquetas alimentos congelados

art. cm. pcs/pz  
44630-04 7x4,5 500



**Labels TMC**

Etichette TMC  
Etiketten TMC  
Etiquettes TMC  
Etiquetas TMC

art. cm. pcs/pz  
44630-05 7x4,5 500

**TMC: Termine minimo di conservazione.**

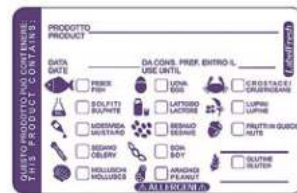

**Labels Allergens**

Etichette allergeni  
Etiketten Allergene  
Etiquettes allergènes  
Etiquetas alérgenos

art. cm. pcs/pz  
44630-06 7x4,5 500



**Labels delivery with allergens**

Etichette delivery con allergeni  
Etiketten Lieferung mit Allergenen  
Etiquettes livraison avec allergènes  
Etiquetas entrega con alérgenos

art. cm. pcs/pz  
44630-07 14x4,5 250



**Wall clock ORION**

Orologio da parete  
Wanduhr  
Horloge à paroi  
Reloj de pared

art. Ø cm.  
41380-01 29

**Satin alloy. – Metallo satinato.**



**Wall clock SILENT**

Orologio da parete  
Wanduhr  
Horloge à paroi  
Reloj de pared

art. Ø cm.  
41380-02 30,5

**Silent clock. – Movimento silenzioso.**



ABS  
SS

**Digital scale**

Bilancia digitale  
Präzisionswaage  
Balance digitale  
Balanza digital

art. cm. Kg. scala  
49865-06 21,6x17,1x6,3 6 1g

**Antimicrobial protection. Portion count. Removable platform cm 14,6x16,5. AC adapter/batteries supply. – Protezione antimicrobica. Conteggio porzioni. Piattaforma cm 4,6x16,5. Adattatore AC/batterie.**



**Digital scale**

Bilancia digitale  
Präzisionswaage  
Balance digitale  
Balanza digital

art. cm. Kg. scala  
49865-70 30,5x31,8x5,7 68 100g

**Platform cm 30,5x30,5. Remote LCD wall mount display. Electric or batteries supply. Piattaforma cm 30,5x30,5. Schermo LCD rimovibile per montaggio a parete. Alimentazione corrente/batteria.**



ABS







SS

**Mechanical scale**  
Bilancia meccanica  
Waage  
Balance  
Balanza

| art.     | Ø cm. | Kg. | scala |
|----------|-------|-----|-------|
| 49864-03 | 20    | 3   | 10g   |
| 49864-05 | 20    | 5   | 20g   |



SS

**Mechanical scale**  
Bilancia meccanica  
Waage  
Balance  
Balanza

| art.     | Ø cm. | Kg. | scala |
|----------|-------|-----|-------|
| 49864-20 | 25    | 20  | 100g  |



SS

**Digital kitchen scale**  
Bilancia digitale da cucina  
Digital-Küchenwaage  
Balance de cuisine  
Balanza digital de cocina

| art.     | cm.     | Kg. | scala |
|----------|---------|-----|-------|
| 49773-05 | 21,5x13 | 5   | 1g    |



SS

ABS

**Digital kitchen scale**  
Bilancia digitale da cucina  
Digital-Küchenwaage  
Balance de cuisine  
Balanza digital de cocina

| art.     | cm.         | Kg. | scala |
|----------|-------------|-----|-------|
| 49774-05 | 22,5x16,5x2 | 5   | 1g    |



**Pocket scale**  
Bilancia tascabile  
Taschenwaage  
Balance de poche  
Balanza de bolsillo

| art.     | cm.       | Kg.  | scala |
|----------|-----------|------|-------|
| 49771-00 | 15x10x2,5 | 0,25 | 0,1 g |



SS

ABS

**Pocket scale**  
Bilancia tascabile  
Taschenwaage  
Balance de poche  
Balanza de bolsillo

| art.     | cm.        | Kg. | scala |
|----------|------------|-----|-------|
| 49772-01 | 12,7x7,6x2 | 1   | 0,1 g |



ABS

SS

**Digital scale**  
Bilancia digitale  
Digitalwaage  
Balance digitale  
Balanza digital

| art.     | cm.         | Kg. | scala |
|----------|-------------|-----|-------|
| 49775-05 | 24,5x31x9,5 | 5   | 1g    |
| 49775-10 | 24,5x31x9,5 | 10  | 1g    |



ABS

SS

**Digital scale**  
Bilancia digitale  
Digitalwaage  
Balance digitale  
Balanza digital

| art.     | cm.        | Kg. | scala |
|----------|------------|-----|-------|
| 49777-50 | 29x33,5x11 | 50  | 1g    |

Unit: Kg/lb.



SS

**Digital scale**  
 Bilancia digitale  
 Digitalwaage  
 Balance digitale  
 Balanza digital

| art.     | cm.      | Kg. | scala |
|----------|----------|-----|-------|
| 49776-15 | 24x29x11 | 15  | 1g    |
| 49776-30 | 24x29x11 | 30  | 2g    |



ABS

SS

**Digital scale with platform**  
 Bilancia digitale con piattaforma  
 Digitalwaage mit Plattform  
 Balance digitale avec plate-forme  
 Balanza digital con plataforma

| art.     | cm.      | Kg. | scala |
|----------|----------|-----|-------|
| 49779-15 | 50x40x84 | 150 | 20g   |
| 49779-30 | 60x50x84 | 300 | 50g   |

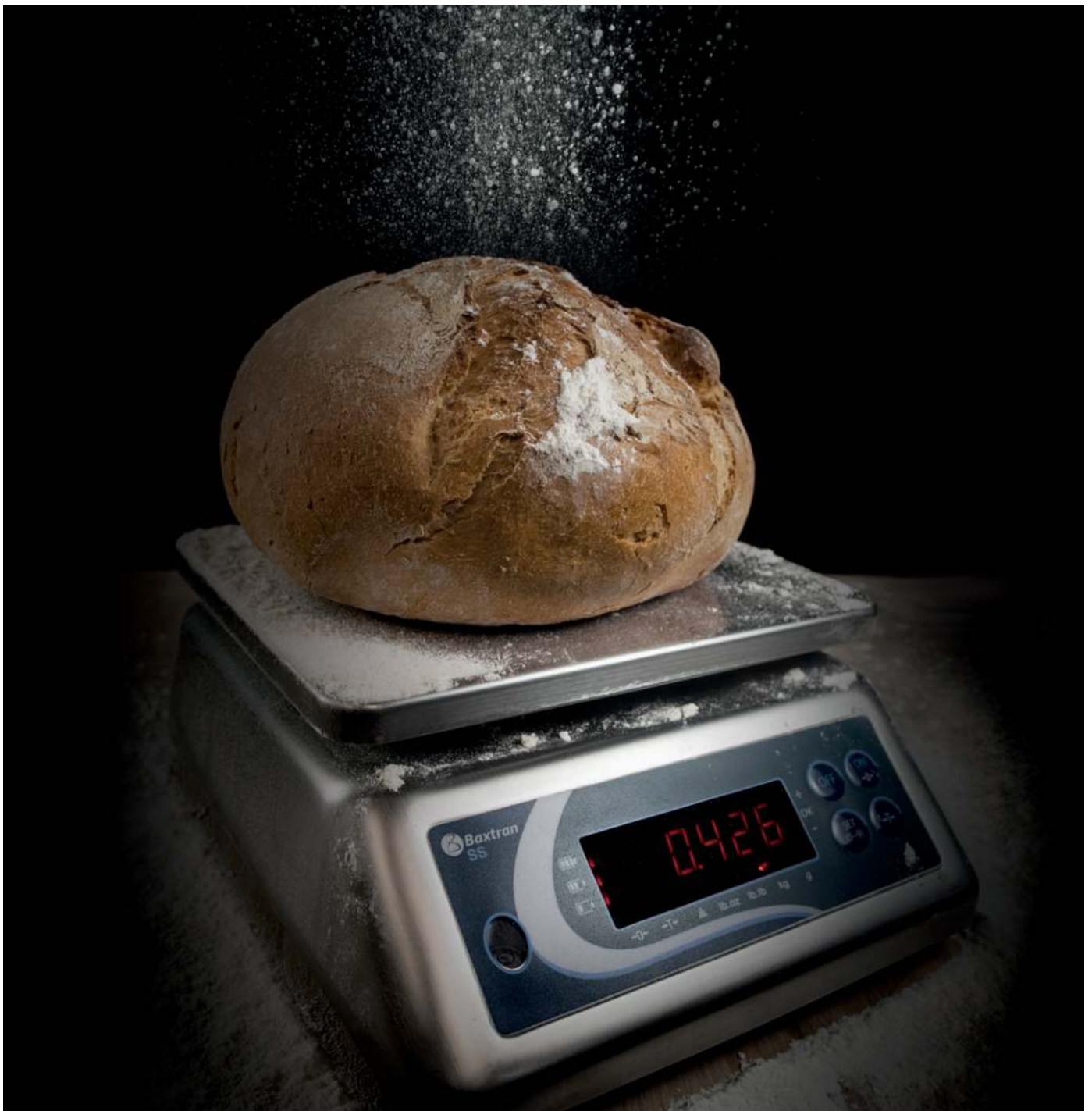



# SERIES 18100

FORGED KNIVES  
COLTELLI FORGIATI



A deep study and computerised tests of ergonomics, movement and posture have allowed Paderno to create a professional knives line, that is the synthesis of comfort and cutting precision. Handle made of plastic specially developed for the food processing sector, ergonomic design with soft edges, perfect grip to ensure precise guidance. The forged blade realised in special steel and molybdenum/vanadium, thanks to a peculiar hardening process, guarantees to the product a perfect cut and a long life of the blade's edge.

Uno studio approfondito e prove computerizzate di ergonomia, movimento e postura hanno permesso a Paderno di creare una linea di coltelli professionali, sintesi perfetta tra comfort e perfezione del taglio. Manico realizzato in speciale materiale plastico sviluppato per il settore alimentare, design ergonomico con bordi arrotondati, presa perfetta per garantire un taglio di precisione. Lama forgiata realizzata in lega di speciale acciaio, molibdeno e vanadio con particolare processo di tempra che garantisce al prodotto un ottimo taglio ed una perfetta e lunga tenuta di filo.



**Cook's knife**

Coltello cucina  
Kochmesser  
Couteau cuisine  
Cuchillo de cocinero

| art.     | cm. |
|----------|-----|
| 18100-16 | 16  |
| 18100-20 | 20  |
| 18100-24 | 24  |
| 18100-30 | 30  |
| 18100-36 | 36  |



**Butcher's knife**

Coltello francese  
Blockmesser  
Couteau de chef  
Cuchillo de carnicero

| art.     | cm. |
|----------|-----|
| 18102-16 | 16  |
| 18102-20 | 20  |
| 18102-26 | 26  |
| 18102-30 | 30  |



**Oriental knife**

Coltello orientale  
Japanisches Kochmesser  
Couteau de chef japonais  
Cuchillo santoku

| art.     | cm. |
|----------|-----|
| 18103-18 | 18  |



**Oriental knife, scalloped edge**

Coltello orientale, alveolato  
Japanisches Kochmesser mit Kullenschliff  
Couteau de chef japonais alveolé  
Cuchillo santoku alveolado

| art.     | cm. |
|----------|-----|
| 18104-18 | 18  |



**Slicing knife**

Coltello affettare  
Fleischmesser  
Tranchelard  
Cuchillo trinchante

| art.     | cm. |
|----------|-----|
| 18106-15 | 15  |
| 18106-20 | 20  |
| 18106-25 | 25  |
| 18106-30 | 30  |



**Ham knife**

Coltello prosciutto  
Schinkenmesser  
Trancheur à jambon  
Cuchillo para jamón

| art.     | cm. |
|----------|-----|
| 18109-26 | 26  |
| 18109-30 | 30  |
| 18109-36 | 36  |



**Ham knife, scalloped edge**

Coltello prosciutto, alveolato  
Schinkenmesser mit Kullenschliff  
Couteau à jambon alvéolé  
Cuchillo para jamón alveolado

| art.     | cm. |
|----------|-----|
| 18110-26 | 26  |
| 18110-30 | 30  |
| 18110-36 | 36  |



**Salmon knife**

Coltello salmone  
Lachsmesser  
Couteau à saumon  
Cuchillo para salmón

| art.     | cm. |
|----------|-----|
| 18111-30 | 30  |



**Salmon knife, scalloped edge**

Coltello salmone, alveolato  
Lachsmesser mit Kullenschliff  
Couteau à saumon alvéolé  
Cuchillo para salmón alveolado

| art.     | cm. |
|----------|-----|
| 18112-30 | 30  |



**Carving knife**

Coltello trinciante  
Tranchiermesser  
Couteau à découper  
Cuchillo trinchante

| art.     | cm. |
|----------|-----|
| 18114-20 | 20  |







**Filleting knife, flexible**

Coltello filettare, flessibile  
Filiermesser, flexibel  
Couteau filet de sole, flexible  
Cuchillo para filetear, flexible

| art.     | cm. |
|----------|-----|
| 18115-20 | 20  |
| 18115-25 | 25  |



**Boning knife**

Coltello disosso  
Ausbeinmesser  
Couteau à désosser  
Cuchillo deshuesador

| art.     | cm. |
|----------|-----|
| 18116-14 | 14  |
| 18116-18 | 18  |



**Steak knife serrated**

Coltello bistecca seghettato  
Steakmesser Wellenschliff  
Couteau à steak dentelé  
Cuchillo steak filo ondulado

| art.     | cm. |
|----------|-----|
| 18122-12 | 12  |



**Paring knife**

Spelucchino  
Spickmesser  
Couteau d'office  
Cuchillo mondador

| art.     | cm. |
|----------|-----|
| 18124-09 | 9   |



**Paring knife**

Spelucchino  
Spickmesser  
Couteau d'office  
Cuchillo mondador

| art.     | cm. |
|----------|-----|
| 18125-07 | 7   |
| 18125-10 | 10  |



**Bent paring knife**

Coltello cuoco  
Tourniermesser  
Couteau bec d'oiseau  
Cuchillo para pelar

| art.     | cm. |
|----------|-----|
| 18126-07 | 7   |



**Table knife serrated**

Coltello tavola seghettato  
Tafelmesser Wellenschliff  
Couteau bout rond cranté  
Cuchillo mesa filo ondulado

| art.     | cm. |
|----------|-----|
| 18123-11 | 11  |



**Bread knife**

Coltello pane  
Brotmesser  
Couteau à pain  
Cuchillo para pan

| art.     | cm. |
|----------|-----|
| 18128-20 | 20  |
| 18128-24 | 24  |
| 18128-30 | 30  |



**Meat fork**

Forchettone  
Fleischgabel  
Fourchette baïonnette  
Tenedor trinchante

| art.     | cm. |
|----------|-----|
| 18230-13 | 13  |
| 18230-17 | 17  |



**Carving fork**

Forchettone curvo  
Fleischgabel  
Fourchette courbe  
Tenedor trinchante

| art.     | cm. |
|----------|-----|
| 18231-13 | 13  |

# SERIES 18000

STAMPED KNIVES  
COLTELLI TRANCIATI



The professional cutlery line "Color-Line" helps to reduce the risk of cross contamination using a Color Coding System which identifies each knife with a specific task: different food processing areas are easily identified. The steel used for this cutlery line has exceptional hardness and very high resistance to corrosion due to ICE-HARDENED system, a special process to harden the steel.

La linea di coltelleria professionale "CCS"– Color Coding System riduce i rischi di contaminazione incrociata grazie all'utilizzo di un Sistema di Codifica dei Colori che identifica ogni coltello per un uso specifico e permette di individuare facilmente le diverse aree di lavoro. Gli acciai utilizzati per questa linea di coltelleria presentano un'eccezionale durezza ed elevata resistenza alla corrosione, grazie all'uso del sistema ICE-HARDENING, processo speciale per temperare l'acciaio.



**Cook's knife**

Coltello cucina  
Kochmesser  
Couteau de cuisine  
Cuchillo de cocinero

| art.     | cm. | col. |
|----------|-----|------|
| 18000-16 | 16  | ●    |
| 18000-20 | 20  | ●    |
| 18000-23 | 23  | ●    |
| 18000-26 | 26  | ●    |
| 18000-30 | 30  | ●    |
| 18000-36 | 36  | ●    |



**Cook's knife**

Coltello cucina  
Kochmesser  
Couteau de cuisine  
Cuchillo de cocinero

| art.     | cm. | col. |
|----------|-----|------|
| 18000B16 | 16  | ●    |
| 18000B20 | 20  | ●    |
| 18000B23 | 23  | ●    |
| 18000B26 | 26  | ●    |
| 18000B30 | 30  | ●    |



**Cook's knife**

Coltello cucina  
Kochmesser  
Couteau de cuisine  
Cuchillo de cocinero

| art.     | cm. | col. |
|----------|-----|------|
| 18000G16 | 16  | ●    |
| 18000G20 | 20  | ●    |
| 18000G23 | 23  | ●    |
| 18000G26 | 26  | ●    |
| 18000G30 | 30  | ●    |



**Cook's knife**

Coltello cucina  
Kochmesser  
Couteau de cuisine  
Cuchillo de cocinero

| art.     | cm. | col. |
|----------|-----|------|
| 18000M16 | 16  | ●    |
| 18000M20 | 20  | ●    |
| 18000M23 | 23  | ●    |
| 18000M26 | 26  | ●    |



**Cook's knife**

Coltello cucina  
Kochmesser  
Couteau de cuisine  
Cuchillo de cocinero

| art.     | cm. | col. |
|----------|-----|------|
| 18000R16 | 16  | ●    |
| 18000R20 | 20  | ●    |
| 18000R23 | 23  | ●    |
| 18000R26 | 26  | ●    |
| 18000R30 | 30  | ●    |



**Cook's knife**

Coltello cucina  
Kochmesser  
Couteau de cuisine  
Cuchillo de cocinero

| art.     | cm. | col. |
|----------|-----|------|
| 18000W20 | 20  | ○    |
| 18000W26 | 26  | ○    |
| 18000W30 | 30  | ○    |



**Cook's knife**

Coltello cucina  
Kochmesser  
Couteau de cuisine  
Cuchillo de cocinero

| art.     | cm. | col. |
|----------|-----|------|
| 18000Y16 | 16  | ●    |
| 18000Y20 | 20  | ●    |
| 18000Y23 | 23  | ●    |
| 18000Y26 | 26  | ●    |



**Slaughter/Butcher's knife**

Coltello scimitarra  
Schlacht U Fleischermesser  
Couteau à découper  
Cuchillo carnicero curvo

| art.     | cm. | col. |
|----------|-----|------|
| 18005-22 | 22  | ●    |
| 18005-27 | 27  | ●    |
| 18005-32 | 32  | ●    |



**Slaughter/Butcher's knife**

Coltello scimitarra  
Schlacht U Fleischermesser  
Couteau à découper  
Cuchillo carnicero curvo

| art.     | cm. | col. |
|----------|-----|------|
| 18005B22 | 22  | ●    |
| 18005B27 | 27  | ●    |
| 18005B32 | 32  | ●    |



**Slaughter/Butcher's knife**

Coltello scimitarra  
Schlacht U Fleischermesser  
Couteau à découper  
Cuchillo carnicero curvo

| art.     | cm. | col. |
|----------|-----|------|
| 18005G22 | 22  | ●    |
| 18005G27 | 27  | ●    |
| 18005G32 | 32  | ●    |



**Slaughter/Butcher's knife**

Coltello scimitarra  
Schlacht U Fleischermesser  
Couteau à découper  
Cuchillo carnicero curvo

| art.     | cm. | col. |
|----------|-----|------|
| 18005R22 | 22  | ●    |
| 18005R27 | 27  | ●    |
| 18005R32 | 32  | ●    |



**Slaughter/Butcher's knife**

Coltello scimitarra  
Schlacht U Fleischermesser  
Couteau à découper  
Cuchillo carnicero curvo

| art.     | cm. | col. |
|----------|-----|------|
| 18005Y22 | 22  | ●    |
| 18005Y27 | 27  | ●    |
| 18005Y32 | 32  | ●    |



**Butcher's knife**

Coltello francese  
Blockmesser  
Couteau à découper  
Cuchillo carnicero

| art.     | cm. | col. |
|----------|-----|------|
| 18002-18 | 18  | ●    |
| 18002-20 | 20  | ●    |
| 18002-22 | 22  | ●    |
| 18002-26 | 26  | ●    |
| 18002-30 | 30  | ●    |
| 18002-36 | 36  | ●    |



**Butcher's knife**

Coltello francese  
Blockmesser  
Couteau à découper  
Cuchillo carnicero

| art.     | cm. | col. |
|----------|-----|------|
| 18002B26 | 26  | ●    |



**Butcher's knife**

Coltello francese  
Blockmesser  
Couteau à découper  
Cuchillo carnicero

| art.     | cm. | col. |
|----------|-----|------|
| 18002R18 | 18  | ●    |
| 18002R20 | 20  | ●    |
| 18002R22 | 22  | ●    |
| 18002R26 | 26  | ●    |
| 18002R30 | 30  | ●    |
| 18002R36 | 36  | ●    |



**Butcher's knife**

Coltello francese  
Blockmesser  
Couteau à découper  
Cuchillo carnicero

| art.     | cm. | col. |
|----------|-----|------|
| 18002Y18 | 18  | ●    |
| 18002Y26 | 26  | ●    |
| 18002Y30 | 30  | ●    |
| 18002Y36 | 36  | ●    |





**Slicing knife**

Coltello affettare  
Wurstmesser  
Couteau à trancher  
Cuchillo trinchante

| art.     | cm. | col. |
|----------|-----|------|
| 18006-20 | 20  | ●    |
| 18006-25 | 25  | ●    |
| 18006-30 | 30  | ●    |
| 18006-36 | 36  | ●    |



**Slicing knife**

Coltello affettare  
Wurstmesser  
Couteau à trancher  
Cuchillo trinchante

| art.     | cm. | col. |
|----------|-----|------|
| 18006B20 | 20  | ●    |
| 18006B25 | 25  | ●    |
| 18006B30 | 30  | ●    |



**Slicing knife**

Coltello affettare  
Wurstmesser  
Couteau à trancher  
Cuchillo trinchante

| art.     | cm. | col. |
|----------|-----|------|
| 18006G20 | 20  | ●    |
| 18006G25 | 25  | ●    |



**Slicing knife**

Coltello affettare  
Wurstmesser  
Couteau à trancher  
Cuchillo trinchante

| art.     | cm. | col. |
|----------|-----|------|
| 18006R20 | 20  | ●    |
| 18006R25 | 25  | ●    |
| 18006R30 | 30  | ●    |



**Slicing knife**

Coltello affettare  
Wurstmesser  
Couteau à trancher  
Cuchillo trinchante

| art.     | cm. | col. |
|----------|-----|------|
| 18006Y20 | 20  | ●    |
| 18006Y25 | 25  | ●    |
| 18006Y30 | 30  | ●    |



**Slicing knife, wavy blade**

Coltello affettare, dentato  
Wurstmesser mit Wellenschliff  
Couteau à trancher dentelé  
Cuchillo trinchante ondulado

| art.     | cm. | col. |
|----------|-----|------|
| 18007-25 | 25  | ●    |
| 18007-30 | 30  | ●    |
| 18007-36 | 36  | ●    |



**Slicing knife, wavy blade**

Coltello affettare, dentato  
Wurstmesser mit Wellenschliff  
Couteau à trancher dentelé  
Cuchillo trinchante ondulado

| art.     | cm. | col. |
|----------|-----|------|
| 18007G30 | 30  | ●    |



**Cook's knife**

Coltello cucina  
Kochmesser  
Couteau de cuisine  
Cuchillo de cocinero

| art.     | cm. | col. |
|----------|-----|------|
| 18008-20 | 20  | ●    |
| 18008-26 | 26  | ●    |
| 18008-30 | 30  | ●    |
| 18008-36 | 36  | ●    |



**Cook's knife**

Coltello cucina  
Kochmesser  
Couteau de cuisine  
Cuchillo de cocinero

| art.     | cm. | col. |
|----------|-----|------|
| 18008B30 | 30  | ●    |



**Cook's knife**

Coltello cucina  
Kochmesser  
Couteau de cuisine  
Cuchillo de cocinero

| art.     | cm. | col. |
|----------|-----|------|
| 18008R26 | 26  | ●    |
| 18008R30 | 30  | ●    |
| 18008R36 | 36  | ●    |



**Cook's knife**

Coltello cucina  
Kochmesser  
Couteau de cuisine  
Cuchillo de cocinero

| art.     | cm. | col. |
|----------|-----|------|
| 18008Y30 | 30  | ●    |



**Ham knife**

Coltello prosciutto  
Schinkenmesser  
Trancheur à jambon  
Cuchillo para jamón

| art.     | cm. | col. |
|----------|-----|------|
| 18009-25 | 25  | ●    |
| 18009-30 | 30  | ●    |
| 18009-36 | 36  | ●    |



**Ham knife**

Coltello prosciutto  
Schinkenmesser  
Trancheur à jambon  
Cuchillo para jamón

| art.     | cm. | col. |
|----------|-----|------|
| 18009B25 | 25  | ●    |
| 18009B30 | 30  | ●    |



**Ham knife**

Coltello prosciutto  
Schinkenmesser  
Trancheur à jambon  
Cuchillo para jamón

| art.     | cm. | col. |
|----------|-----|------|
| 18009M25 | 25  | ●    |



**Ham knife**

Coltello prosciutto  
Schinkenmesser  
Trancheur à jambon  
Cuchillo para jamón

| art.     | cm. | col. |
|----------|-----|------|
| 18009R25 | 25  | ●    |
| 18009R30 | 30  | ●    |



**Ham knife**

Coltello prosciutto  
Schinkenmesser  
Trancheur à jambon  
Cuchillo para jamón

| art.     | cm. | col. |
|----------|-----|------|
| 18009W25 | 25  | ○    |
| 18009W30 | 30  | ○    |



**Ham knife**

Coltello prosciutto  
Schinkenmesser  
Trancheur à jambon  
Cuchillo para jamón

| art.     | cm. | col. |
|----------|-----|------|
| 18009Y25 | 25  | ●    |
| 18009Y30 | 30  | ●    |



**Salmon knife**

Coltello salmone  
Lachsmesser  
Couteau à saumon  
Cuchillo salmón

| art.     | cm. | col. |
|----------|-----|------|
| 18011-32 | 32  | ●    |



**Ham knife, scalloped edge**

Coltello prosciutto, alveolato  
Schinkenmesser mit Kullenschliff  
Couteau à jambon alvéolé  
Cuchillo para jamón alveolado

| art.     | cm. | col. |
|----------|-----|------|
| 18010-25 | 25  | ●    |
| 18010-30 | 30  | ●    |
| 18010-36 | 36  | ●    |



**Ham knife, scalloped edge**

Coltello prosciutto, alveolato  
Schinkenmesser mit Kullenschliff  
Couteau à jambon alvéolé  
Cuchillo para jamón alveolado

| art.     | cm. | col. |
|----------|-----|------|
| 18010Y30 | 30  | ●    |



**Salmon knife, scalloped edge**

Coltello salmone, alveolato  
Lachsmesser mit Kullenschliff  
Couteau à saumon alvéolé  
Cuchillo salmón alveolado

| art.     | cm. | col. |
|----------|-----|------|
| 18012-32 | 32  | ●    |
| 18012B32 | 32  | ●    |



**Cheese slicer**

Coltello salati/formaggio  
Universalmesser  
Couteau universel  
Cuchillo universal

| art.     | cm. | col. |
|----------|-----|------|
| 18013-30 | 30  | ●    |
| 18013-36 | 36  | ●    |



**Cheese slicer**

Coltello salati/formaggio  
Universalmesser  
Couteau universel  
Cuchillo universal

| art.     | cm. | col. |
|----------|-----|------|
| 18013G36 | 36  | ●    |



**Cheese slicer**

Coltello salati/formaggio  
Universalmesser  
Couteau universel  
Cuchillo universal

| art.     | cm. | col. |
|----------|-----|------|
| 18013W30 | 30  | ○    |
| 18013W36 | 36  | ○    |



**Filetting knife**

Coltello filettare  
Filiermesser  
Couteau filet de sole  
Cuchillo fileteador

| art.     | cm. | col. |
|----------|-----|------|
| 18015-18 | 18  | ●    |
| 18015-22 | 22  | ●    |
| 18015-27 | 27  | ●    |



**Filetting knife**

Coltello filettare  
Filiermesser  
Couteau filet de sole  
Cuchillo fileteador

| art.     | cm. | col. |
|----------|-----|------|
| 18015B18 | 18  | ●    |
| 18015B22 | 22  | ●    |



**Filetting knife**

Coltello filettare  
Filiermesser  
Couteau filet de sole  
Cuchillo fileteador

| art.     | cm. | col. |
|----------|-----|------|
| 18015R18 | 18  | ●    |
| 18015R22 | 22  | ●    |



**Filetting knife**

Coltello filettare  
Filiermesser  
Couteau filet de sole  
Cuchillo fileteador

| art.     | cm. | col. |
|----------|-----|------|
| 18015Y18 | 18  | ●    |
| 18015Y27 | 27  | ●    |



**Boning knife**

Coltello disosso  
Ausbeinmesser  
Couteau à désosser  
Cuchillo deshuesador

| art.     | cm. | col. |
|----------|-----|------|
| 18016-14 | 14  | ●    |
| 18016-16 | 16  | ●    |



**Boning knife**

Coltello disosso  
Ausbeinmesser  
Couteau à désosser  
Cuchillo deshuesador

| art.     | cm. | col. |
|----------|-----|------|
| 18016B14 | 14  | ●    |
| 18016B16 | 16  | ●    |



**Boning knife**

Coltello disosso  
Ausbeinmesser  
Couteau à désosser  
Cuchillo deshuesador

| art.     | cm. | col. |
|----------|-----|------|
| 18016R14 | 14  | ●    |
| 18016R16 | 16  | ●    |



**Boning knife**

Coltello disosso  
Ausbeinmesser  
Couteau à désosser  
Cuchillo deshuesador

| art.     | cm. | col. |
|----------|-----|------|
| 18016W16 | 16  | ○    |



**Boning knife**

Coltello disosso  
Ausbeinmesser  
Couteau à désosser  
Cuchillo deshuesador

| art.     | cm. | col. |
|----------|-----|------|
| 18016Y14 | 14  | ●    |
| 18016Y16 | 16  | ●    |



**Boning knife**

Coltello disosso Emilia  
Ausbeinmesser  
Couteau à désosser  
Cuchillo deshuesador

| art.     | cm. | col. |
|----------|-----|------|
| 18017-14 | 14  | ●    |
| 18017-16 | 16  | ●    |
| 18017-18 | 18  | ●    |



**Boning knife**

Coltello disosso Emilia  
Ausbeinmesser  
Couteau à désosser  
Cuchillo deshuesador

| art.     | cm. | col. |
|----------|-----|------|
| 18017B16 | 16  | ●    |
| 18017R16 | 16  | ●    |
| 18017Y16 | 16  | ●    |



**Poultry sticking knife**

Coltello scannapolli  
Geflügelschlachtmesser  
Couteau à volaille  
Cuchillo deshuesador

| art.     | cm. | col. |
|----------|-----|------|
| 18018-11 | 11  | ●    |
| 18018R11 | 11  | ●    |
| 18018Y11 | 11  | ●    |



**Sticking knife**

Coltello scannare  
Stechmesser  
Couteau à saigner  
Cuchillo deshuesador

| art.     | cm. | col. |
|----------|-----|------|
| 18019-12 | 12  | ●    |
| 18019-14 | 14  | ●    |
| 18019-16 | 16  | ●    |
| 18019-18 | 18  | ●    |
| 18019-20 | 20  | ●    |



**Sticking knife**

Coltello scannare  
Stechmesser  
Couteau à saigner  
Cuchillo deshuesador

| art.     | cm. | col. |
|----------|-----|------|
| 18019R12 | 12  | ●    |
| 18019R16 | 16  | ●    |
| 18019R18 | 18  | ●    |
| 18019R20 | 20  | ●    |



**Frozen food, two serrated edges**

Coltello surgelati a doppia lama seghettata  
Tiefkühlkost-Messer  
Couteau à surgelés  
Cuchillo de congelado

| art.     | cm. | col. |
|----------|-----|------|
| 18020-23 | 23  | ●    |
| 18020B23 | 23  | ●    |
| 18020R23 | 23  | ●    |



**Frozen food special serrated blade**

Coltello surgelati lama seghettata speciale  
Tiefkühlkost-Messer  
Couteau à surgelés  
Cuchillo de congelado

| art.     | cm. | col. |
|----------|-----|------|
| 18021-18 | 18  | ●    |
| 18021B18 | 18  | ●    |
| 18021R18 | 18  | ●    |



**Steak knife**

Coltello bistecca  
Steakmesser  
Couteau à steak  
Cuchillo para steak

| art.     | cm. | col. |
|----------|-----|------|
| 18022-12 | 12  | ●    |



**Table knife, half-waved**

Coltello tavola, mezzo dentato  
Tafelmesser halb gewellt  
Couteau universel, demi-dentelée  
Cuchillo mesa, medio dentado

| art.     | cm. | col. |
|----------|-----|------|
| 18023-11 | 11  | ●    |





**Steak/Pizza knife**

Coltello bistecca/pizza  
Steak-/Pizzamesser  
Couteau à steak/pizza  
Cuchillo para steak/pizza

| art.     | cm. | U. Pack | col. |
|----------|-----|---------|------|
| 18217-12 | 12  | 6       | ●    |



**Paring knife**

Spelucchino  
Spickmesser  
Couteau d'office  
Cuchillo mondador

| art.     | cm. | col. |
|----------|-----|------|
| 18024B08 | 8   | ●    |
| 18024B11 | 11  | ●    |



**Paring knife**

Spelucchino  
Spickmesser  
Couteau d'office  
Cuchillo mondador

| art.     | cm. | col. |
|----------|-----|------|
| 18024M08 | 8   | ●    |
| 18024M11 | 11  | ●    |



**Paring knife**

Spelucchino  
Spickmesser  
Couteau d'office  
Cuchillo mondador

| art.     | cm. | col. |
|----------|-----|------|
| 18024W08 | 8   | ○    |
| 18024W11 | 11  | ○    |



**Bent paring knife**

Coltello cuoco  
Tourniermesser  
Couteau bec d'oiseau  
Cuchillo para pelar

| art.     | cm. | col. |
|----------|-----|------|
| 18026-07 | 7   | ●    |
| 18026B07 | 7   | ●    |



**Confectioner's knife**

Coltello pasticceria  
Bäckmesser  
Couteau de pâtissier  
Cuchillo de pastelero

| art.     | cm. | col. |
|----------|-----|------|
| 18029-25 | 25  | ●    |
| 18029-30 | 30  | ●    |
| 18029-36 | 36  | ●    |



**Paring knife**

Spelucchino  
Spickmesser  
Couteau d'office  
Cuchillo mondador

| art.     | cm. | col. |
|----------|-----|------|
| 18024-08 | 8   | ●    |
| 18024-11 | 11  | ●    |



**Paring knife**

Spelucchino  
Spickmesser  
Couteau d'office  
Cuchillo mondador

| art.     | cm. | col. |
|----------|-----|------|
| 18024G08 | 8   | ●    |
| 18024G11 | 11  | ●    |



**Paring knife**

Spelucchino  
Spickmesser  
Couteau d'office  
Cuchillo mondador

| art.     | cm. | col. |
|----------|-----|------|
| 18024R08 | 8   | ●    |
| 18024R11 | 11  | ●    |



**Paring knife**

Spelucchino  
Spickmesser  
Couteau d'office  
Cuchillo mondador

| art.     | cm. | col. |
|----------|-----|------|
| 18024Y08 | 8   | ●    |



**Bent paring knife**

Coltello cuoco  
Tourniermesser  
Couteau bec d'oiseau  
Cuchillo para pelar

| art.     | cm. | col. |
|----------|-----|------|
| 18026G07 | 7   | ●    |
| 18026M07 | 7   | ●    |



**Confectioner's knife**

Coltello pasticceria  
Bäckmesser  
Couteau de pâtissier  
Cuchillo de pastelero

| art.     | cm. | col. |
|----------|-----|------|
| 18029W25 | 25  | ○    |
| 18029W30 | 30  | ○    |
| 18029W36 | 36  | ○    |



**Bread knife**

Coltello pane  
Brotmesser  
Couteau à pain  
Cuchillo para pan

| art.     | cm. | col. |
|----------|-----|------|
| 18028-21 | 21  | ●    |



**Bread knife**

Coltello pane  
Brotmesser  
Couteau à pain  
Cuchillo para pan

| art.     | cm. | col. |
|----------|-----|------|
| 18028-25 | 25  | ●    |
| 18028-30 | 30  | ●    |
| 18028-36 | 36  | ●    |



**Bread knife**

Coltello pane  
Brotmesser  
Couteau à pain  
Cuchillo para pan

| art.     | cm. | col. |
|----------|-----|------|
| 18028B30 | 30  | ●    |



**Bread knife**

Coltello pane  
Brotmesser  
Couteau à pain  
Cuchillo para pan

| art.     | cm. | col. |
|----------|-----|------|
| 18028M25 | 25  | ●    |



**Bread knife**

Coltello pane  
Brotmesser  
Couteau à pain  
Cuchillo para pan

| art.     | cm. | col. |
|----------|-----|------|
| 18028W21 | 21  | ○    |
| 18028W25 | 25  | ○    |
| 18028W30 | 30  | ○    |
| 18028W36 | 36  | ○    |



**Bread knife**

Coltello pane  
Brotmesser  
Couteau à pain  
Cuchillo para pan

| art.     | cm. | col. |
|----------|-----|------|
| 18028Y25 | 25  | ●    |
| 18028Y30 | 30  | ●    |



**Pastry knife**

Coltello dolce  
Bäckermesser  
Couteau de pâtissier  
Cuchillo de pastelero

| art.     | cm. | col. |
|----------|-----|------|
| 18030-26 | 26  | ●    |
| 18030-31 | 31  | ●    |
| 18030-36 | 36  | ●    |



**Pastry knife**

Coltello dolce  
Bäckermesser  
Couteau de pâtissier  
Cuchillo de pastelero

| art.     | cm. | col. |
|----------|-----|------|
| 18030W26 | 26  | ○    |
| 18030W31 | 31  | ○    |
| 18030W36 | 36  | ○    |

SPECIAL ITEMS  
PEZZI SPECIALI





**Chinese meat cleaver**  
Falcetta cinese  
Chinesishackmesser  
Couteau de chef chinois  
Macheta Chino

| art.     | cm. | col. |
|----------|-----|------|
| 18221-17 | 17  | ●    |
| 18221-19 | 19  | ●    |
| 18221-21 | 21  | ●    |



**Chinese meat cleaver**  
Falcetta cinese  
Chinesishackmesser  
Couteau de chef chinois  
Macheta Chino

| art.     | cm. | col. |
|----------|-----|------|
| 18221B17 | 17  | ●    |
| 18221B19 | 19  | ●    |
| 18221B21 | 21  | ●    |



**Chinese meat cleaver**  
Falcetta cinese  
Chinesishackmesser  
Couteau de chef chinois  
Macheta Chino

| art.     | cm. | col. |
|----------|-----|------|
| 18221G17 | 17  | ●    |
| 18221G19 | 19  | ●    |
| 18221G21 | 21  | ●    |



**Chinese meat cleaver**  
Falcetta cinese  
Chinesishackmesser  
Couteau de chef chinois  
Macheta Chino

| art.     | cm. | col. |
|----------|-----|------|
| 18221M17 | 17  | ●    |
| 18221M19 | 19  | ●    |
| 18221M21 | 21  | ●    |



**Chinese meat cleaver**  
Falcetta cinese  
Chinesishackmesser  
Couteau de chef chinois  
Macheta Chino

| art.     | cm. | col. |
|----------|-----|------|
| 18221R17 | 17  | ●    |
| 18221R19 | 19  | ●    |
| 18221R21 | 21  | ●    |



**Chinese meat cleaver**  
Falcetta cinese  
Chinesishackmesser  
Couteau de chef chinois  
Macheta Chino

| art.     | cm. | col. |
|----------|-----|------|
| 18221Y17 | 17  | ●    |
| 18221Y19 | 19  | ●    |
| 18221Y21 | 21  | ●    |



**Meat cleaver**  
Falcetta macellaio  
Hackmesser  
Couperet  
Macheta

| art.     | cm. | Kg.  | col. |
|----------|-----|------|------|
| 18220-18 | 18  | 0,55 | ●    |
| 18220-20 | 20  | 1,10 | ●    |
| 18220-22 | 22  | 1,30 | ●    |
| 18220-26 | 26  | 1,30 | ●    |



**Meat cleaver**  
Falcetta macellaio  
Hackmesser  
Couperet  
Macheta

| art.     | cm. | Kg.  | col. |
|----------|-----|------|------|
| 18220B18 | 18  | 0,55 | ●    |
| 18220B20 | 20  | 1,10 | ●    |
| 18220B22 | 22  | 1,30 | ●    |
| 18220B26 | 26  | 1,30 | ●    |







**Meat cleaver**

Falcetta macellaio  
Hackmesser  
Couperet  
Macheta

| art.     | cm. | Kg.  | col. |
|----------|-----|------|------|
| 18220R18 | 18  | 0,55 | ●    |
| 18220R20 | 20  | 1,10 | ●    |
| 18220R22 | 22  | 1,30 | ●    |
| 18220R26 | 26  | 1,30 | ●    |



**Meat cleaver**

Falcetta macellaio  
Hackmesser  
Couperet  
Macheta

| art.     | cm. | Kg.  | col. |
|----------|-----|------|------|
| 18220Y18 | 18  | 0,55 | ●    |
| 18220Y20 | 20  | 1,10 | ●    |
| 18220Y22 | 22  | 1,30 | ●    |
| 18220Y26 | 26  | 1,30 | ●    |



**Heavy butcher's knife**

Mezzo colpo  
Kochschlagmesser  
Couteau coup lourd  
Cuchillo de carnicero

| art.     | cm. | Kg.  | col. |
|----------|-----|------|------|
| 18224-28 | 28  | 0,75 | ●    |
| 18224B28 | 28  | 0,75 | ●    |
| 18224R28 | 28  | 0,75 | ●    |
| 18224Y28 | 28  | 0,75 | ●    |



**Heavy butcher's knife**

Colpo  
Kochschlagmesser  
Couteau coup lourd  
Cuchillo de carnicero

| art.     | cm. | Kg. | col. |
|----------|-----|-----|------|
| 18225-28 | 28  | 1   | ●    |
| 18225R28 | 28  | 1   | ●    |



**Parmesan cheese knife**

Coltello grana  
Parmesanmesser  
Couteau à Parmesan  
Cuchillo Para Queso Parmenoso

| art.     | cm. | col. |
|----------|-----|------|
| 18205-10 | 10  | ●    |



**Parmesan cheese knife**

Coltello grana  
Parmesanmesser  
Couteau à Parmesan  
Cuchillo Para Queso Parmenoso

| art.     | cm. | col. |
|----------|-----|------|
| 18205-12 | 12  | ●    |



**Parmesan cheese knife**

Coltello segnaforme  
Parmesanmesser  
Couteau à Parmesan  
Cuchillo Para Queso Parmenoso

| art.     | cm. | col. |
|----------|-----|------|
| 18206-09 | 9   | ●    |



**Parmesan cheese knife**

Coltello lancia Milano  
Parmesanmesser  
Couteau à Parmesan  
Cuchillo Para Queso Parmenoso

| art.     | cm. | col. |
|----------|-----|------|
| 18207-15 | 15  | ●    |



**Oyster knife**

Coltello apriatrice  
Austernmesser  
Couteau à huîtres  
Cuchillo para ostras

| art.     | cm. | col. |
|----------|-----|------|
| 18209-06 | 15  | ●    |



**Cheese knife 2 handles**

Coltello formaggio  
Käsemesser  
Couteau à fromage  
Cuchillo para queso

| art.     | cm. | col. |
|----------|-----|------|
| 18201-36 | 36  | ●    |



**Vegetable knife**  
Coltello verdure  
Gemüsemesser  
Couteau à légumes  
Cuchillo para verduras

| art.     | cm. | col. |
|----------|-----|------|
| 18222-18 | 18  | ●    |



**Ham boner**  
Cannula disosso prosciutti  
Schinkenauslöser  
Gouge à jambons  
Cuchillo deshuesar jamón

| art.     | cm. | col. |
|----------|-----|------|
| 48021-21 | 21  | ●    |



**Cheese knife**  
Coltello formaggio  
Käsemesser  
Couteau à fromage  
Cuchillo para queso

| art.     | cm. | col. |
|----------|-----|------|
| 18203-26 | 26  | ●    |



**Baking pan knife**  
Coltello gastronomia  
Winkelmesser  
Couteau à angle  
Cuchillo hoja angular

| art.     | cm.  | col. |
|----------|------|------|
| 18215-13 | 13,5 | ●    |



**Baking pan knife**  
Coltello gastronomia  
Winkelmesser  
Couteau à angle  
Cuchillo hoja angular

| art.     | cm.  | col. |
|----------|------|------|
| 18215-21 | 21,5 | ●    |



**Pie knife**  
Coltello torta  
Tortenmesser  
Couteau à gâteau  
Cuchillo para tartas

| art.     | cm. | col. |
|----------|-----|------|
| 18514-18 | 18  | ●    |



**Mincing knife**  
Mezzaluna  
Wiegemesser  
Hachoir  
Media luna

| art.     | cm. | col. |
|----------|-----|------|
| 48017-14 | 14  | ●    |
| 48017-25 | 26  | ●    |



**Double blade mincing knife**  
Mezzaluna, lama doppia  
Wiegemesser, Doppel-Klinge  
Hachoir double lame  
Media luna, doble

| art.     | cm. | col. |
|----------|-----|------|
| 48215-14 | 14  | ●    |
| 48215-30 | 30  | ●    |



**Meat fork**  
Forchettone  
Fleischgabel  
Fourchette baïonnette  
Tenedor Trinchante

| art.     | cm. | col. |
|----------|-----|------|
| 18226-17 | 17  | ●    |
| 18226B17 | 17  | ●    |
| 18226G17 | 17  | ●    |



**Meat fork**  
Forchettone  
Fleischgabel  
Fourchette baïonnette  
Tenedor Trinchante

| art.     | cm. | col. |
|----------|-----|------|
| 18226R17 | 17  | ●    |
| 18226W17 | 17  | ○    |
| 18226Y17 | 17  | ●    |



**Sharpening steel**

Acciaino  
Wetzstahl  
Fusil  
Chaira

| art.     | cm. | col. |
|----------|-----|------|
| 18235-26 | 26  | ●    |



**Sharpening steel**

Acciaino  
Wetzstahl  
Fusil  
Chaira

| art.     | cm. | col. |
|----------|-----|------|
| 18235-30 | 30  | ●    |
| 18235B30 | 30  | ●    |
| 18235G30 | 30  | ●    |



**Sharpening steel**

Acciaino  
Wetzstahl  
Fusil  
Chaira

| art.     | cm. | col. |
|----------|-----|------|
| 18235R30 | 30  | ●    |
| 18235W30 | 30  | ○    |
| 18235Y30 | 30  | ●    |



**Oval sharpening steel**

Acciaino ovale  
Wetzstahl, oval  
Fusil ovale  
Chaira ovalada

| art.     | cm. | col. |
|----------|-----|------|
| 18236-30 | 30  | ●    |



**Diamond sharpening steel**

Acciaino diamantato  
Diamant-Wetzstahl  
Fusil diamant  
Chaira adiamantada

| art.     | cm. | col. |
|----------|-----|------|
| 18237-26 | 26  | ●    |



**Sharpening stone GRIT 1000/240**

Pietra per affilare  
Abziehstein  
Pierre à aiguiser  
Piedra de afilar

| art.     | cm.    |
|----------|--------|
| 18251-01 | 21x7x3 |



**Sharpening stone GRIT 1000/600**

Pietra per affilare  
Abziehstein  
Pierre à aiguiser  
Piedra de afilar

| art.     | cm.    |
|----------|--------|
| 18251-02 | 21x7x3 |



**Poultry shears**

Trinciapollo  
Geflügelschere  
Coupe-volailles  
Tijeras aves

| art.     | cm. |
|----------|-----|
| 18263-00 | 25  |



**Poultry scissors, divisible**

Forbice pollame, smontabile  
Geflügelschere, teilbar  
Coupe-volailles divisible  
Tijeras aves, desmontables

| art.     | cm.  |
|----------|------|
| 18275-00 | 26,5 |



**Poultry shears, divisible**

Trinciapollo, smontabile  
Geflügelschere, teilbar  
Coupe-volailles divisible  
Tijeras aves, desmontables

| art.     | cm. |
|----------|-----|
| 18261-00 | 24  |



**Seadfood scissors**

Forbice gamberi  
Meeresfrüchteschere  
Ciseaux à crevettes  
Tijeras camarónes

art. cm.

18278-00 18



**Herb scissors, 5 blades**

Forbice erbe, 5 lame  
Kräuterschere 5 Klingen  
Ciseaux à herbes 5 lames  
Tijeras hierbas 5 Cuchillas

art. cm.

18277-00 20



**Salad scissors**

Forbice insalata  
Salatschere  
Ciseaux à salade  
Tijeras ensalada

art. cm.

18270-22 22



**Quail egg cutter**

Forbice uova di quaglia  
Wachteleierschere  
Ciseaux oeufs de caille  
Tijeras huevos de codorniz

art. cm.

18279-14 14



**All purpose scissors**

Forbice multiuso  
Küchenschere  
Ciseaux de cuisine  
Tijeras cocina

art. cm.

18272-00 18,5



**Kitchen scissors, divisible**

Forbice cucina, smontabile  
Küchenschere, teilbar  
Ciseaux de cuisine, divisible  
Tijeras cocina, desmontables

art. cm.

18271-00 22,6



**Kitchen scissors, divisible**

Forbice cucina, smontabile  
Küchenschere, teilbar  
Ciseaux de cuisine, divisible  
Tijeras cocina, desmontables

art. cm.

18273-00 18



**Kitchen scissors, divisible**

Forbice cucina, smontabile  
Küchenschere, teilbar  
Ciseaux de cuisine, divisible  
Tijeras cocina, desmontables

art. cm.

18274-00 20





**Chinese kitchen scissors**  
Forbice cinese cucina  
Chinesische Küchenschere  
Ciseaux chinois de cuisine  
Tijeras chinas de cocina

art. cm.  
49636-00 17x8,5

Stainless steel and brass. – Inox e ottone.



**Pizza scissors, divisible**  
Forbice pizza, smontabile  
Pizzaschere, teilbar  
Ciseaux à pizza, divisible  
Tijeras pizza, desmontables

art. cm.  
18276-00 25



# JAPANESE SUSHI KNIVES COLTELLI SUSHI GIAPPONESI

KNIVES  
COLTELLERIA



Excellent choice when preparing sushi and vegetables. Molybdenum/Vanadium s/s blades for excellent edge retention, razor sharp edges, slip resistant wooden handles. The blades are sharpened with the traditional Japanese single bevel to improve sharpness. The large beveled one-sided edge is much thinner than a two-sided edge. This thinner, sharper edge makes for cleaner cuts through the soft flesh of fish, in particular. Using these knives will avoid bruising the delicate texture of raw fish and destroying the freshness of the fish. The thinner edge is more fragile than the edge on western knives. Do not use for cutting anything solid including larger fish bones. Due to the special blade sharpening and s/s used we highly recommend to only hand wash and dry the blades thoroughly immediately.

Una scelta eccellente per la preparazione di sushi e verdure. Lame in acciaio inox, molibdeno e vanadio, per un'ottimale tenuta del filo, affilatura a rasoio, manici in legno antiscivolo. Secondo la tradizione giapponese l'affilatura è unilaterale ed il filo è molto più sottile rispetto a quello della normale affilatura dei coltelli occidentali. Questo rende i tagli più nitidi ed evita di creare traumi alla trama delicata di carne e pesce crudo. Non utilizzare per il taglio di solidi incluse grosse lisce di pesce. Data la particolarità dell'affilatura e dell'acciaio piegato si consiglia vivamente di lavare a mano ed asciugare immediatamente con cura le lame.



**DEBA**

| art.     | l. cm. |
|----------|--------|
| 18280-22 | 22,5   |
| 18280-16 | 16,5   |
| 18280-10 | 10,5   |

**The Deba is a powerful knife used for filleting fish and butchering meat without bones. Its weight and thickness can chop through fish bones and the sharp edge can fillet even the smallest of fish.** – Affilato e dalla lama pesante usato per disossare e tagliare il pesce utilizzato nel sushi. È simile ad un coltello da chef.



**OROSHI**

| art.     | l. cm. |
|----------|--------|
| 18281-24 | 24     |

**An Oroshi Knife is a Japanese all-purpose cooking knife, but used particularly for fish.** – Per sfilettare il tonno e altri pesci di grandi dimensioni.



**USUBA**

| art.      | l. cm. |
|-----------|--------|
| 18282-22  | 22,5   |
| 18282-18  | 18,0   |
| 18282-19* | 18,0   |

**\*Double bevel. The Usuba is the ultimate vegetable knife. Sharp and thin, it is used by chefs in Japan for katsuramuki, a traditional style of peeling vegetables into thin sheets.** – \*Doppia affilatura. Coltello estremamente affilato con una punta quadrata. Questo coltello è usato per tagliare verdure e quando è tenuto ben affilato può tagliarle in fette sottili come un foglio di carta.



**TAKO SASHIMI**

| art.     | l. cm. |
|----------|--------|
| 18283-33 | 33     |
| 18283-27 | 27     |

**The Tako Sashimi is a variation of the Yanagi and is used to slice straight-cut sashimi. The blunt tip and balanced weight works well on difficult ingredients like octopus, from which it gets its name. Originated in Kanto (Tokyo) region.** – Il coltello Tako Sashimi assomiglia di più ad un coltello occidentale ed è utilizzato per affettare tagli spessi di carne per sushi. Ha la lama senza punta, per evitare di rovinare i tentacoli del polpo.



**YANAGI SASHIMI**

| art.     | l. cm. |
|----------|--------|
| 18284-21 | 21     |
| 18284-27 | 27     |
| 18284-30 | 30     |
| 18284-33 | 33     |

**The Yanagi Sashimi is a slicing knife used to cut boneless fish fillets into sashimi and topping for sushi. The graceful, thin blade cuts beautiful slices in one long, drawing stroke. Originated in Kansai (Osaka) region.** – Viene utilizzato per tagliare sottili fette di verdure, carne o pesce, nonché per tagliare in generale a dadi o a fette. Grazie alla sua lama sottile ed affilata è utilizzato anche per creare guarnizioni o tagliare i rotoli di sushi.





**Knife case, 14 pieces**  
Valigia cuoco, 14 pz.  
Messerkoffer, 14 Stk.  
Mallette de chef, 14 pièces  
Maleta cuchillos, 14 piezas

| art.     | des.                           |
|----------|--------------------------------|
| 18099-15 | Comprende/includes:            |
| 18000-26 | cook's knife/cucina cm 26      |
| 18000-30 | cook's knife/cucina cm 30      |
| 18002-18 | butcher's knife/francese cm 18 |
| 18002-26 | butcher's knife/francese cm 26 |
| 18009-30 | ham/prosciutto cm 30           |
| 18016-16 | boning/disosso cm 6            |
| 18024-11 | paring/spelucchino cm 11       |
| 18026-07 | paring/spelucchino cm 7        |
| 18028-30 | bread/pane cm 30               |
| 18230-17 | fork/forchettone cm 17         |
| 18235-30 | sharpener/acciaino cm 30       |
| 18519-26 | spatula/spatola cm 26          |
| 48280-34 | peeler/pelapatate              |
| 18276-00 | scissors/forbice pizza         |

**Knife case, 17 pcs**  
Valigia cuoco, 17 pz.  
Messerkoffer, 17 Stk.,  
Mallette de chef, 17 pcs  
Maleta cuchillos, 17 piezas

| art.     | des.                         |
|----------|------------------------------|
| 18199-19 | Comprende/includes:          |
| 18100-24 | cook's knife/cucina cm 24    |
| 18100-30 | cook's knife/cucina cm 30    |
| 18112-30 | salmon/salmone cm 30         |
| 18115-20 | filetting/filettare cm 20    |
| 18116-14 | boning/disosso cm 14         |
| 18125-10 | paring/spelucchino cm 10     |
| 18126-07 | bent paring/spelucchino cm 7 |
| 18128-30 | bread/pane cm 30             |
| 18230-17 | fork/forchettone cm 17       |
| 18235-30 | sharpener/acciaino cm 30     |
| 18276-00 | scissors/forbice pizza       |
| 18255-00 | sharpener/affila coltelli    |
| 48280-25 | apple corer/levatorsoli      |
| 48280-34 | peeler/pelapatate            |
| 48280-02 | can opener/apribottiglie     |
| 48280-27 | melon baller/scavino         |
| 48280-92 | striper/decora limoni        |







**Knife roll-bag, 9 pieces forged**

Rotolo portacoltelli, 9 pz. forgiati

Messer-Rolltasche, 9-teilig

Rouleau pour couteaux, 9 pièces

Estuche cuchillos, 9 piezas

| art.     | des.                   |
|----------|------------------------|
| 18190-09 | Comprende/includes:    |
| 18116-14 | boning/disosso cm 9    |
| 18100-24 | cook's/cucina cm 24    |
| 18106-25 | slicer/affettare cm 25 |
| 18109-26 | ham/prosciutto cm 24   |



| art.     | des.               |
|----------|--------------------|
| 18124-09 | paring/spelucchino |
| 18128-24 | bread/pane cm 14   |
| 18230-17 | fork/forchettone   |
| 18235-26 | sharpener/acciaino |
| 18271-00 | scissors/forbice   |



**Knife block, 9 pcs set**

Ceppo portacoltelli, set 9 pz

Messerblock, 9-tlg.

Bloc à couteaux, set 9 pièces

Bloque portacuchillos, 9 piezas

| art.     | des.                    |
|----------|-------------------------|
| 18192-09 | Comprende/includes:     |
| 18100-20 | cook's/cucina cm 20     |
| 18106-20 | slicer/affettare cm 20  |
| 18124-09 | paring/spelucchino cm 9 |
| 18128-20 | bread/pane cm 20        |



| art.     | des.                     |
|----------|--------------------------|
| 18230-17 | fork/forchettone cm 17   |
| 18235-26 | sharpener/acciaino cm 26 |
| 18271-00 | scissors/forbice         |
| 18102-16 | butcher's/francese cm 16 |
| 18126-07 | paring/cuoco cm 7        |





**Magnetic knife rack**

Barra magnetica  
Magnet-Messerhalter  
Porte-couteaux magnetic  
Barra magnética portas cuchillos

| art.     | cm. |
|----------|-----|
| 48032-30 | 30  |
| 48032-45 | 45  |
| 48032-60 | 60  |



**Knife block**

Ceppo porta coltelli  
Messerblock  
Bloc à couteaux  
Bloque portacuchillos

| art.     | cm.      |
|----------|----------|
| 49875-06 | 26x14x33 |



**Knife rack**

Porta coltelli  
Messeraufhänger  
Support à couteaux  
Porta cuchillos

| art.     | cm.           |
|----------|---------------|
| 48040-00 | 30,5x6,6x30,5 |

**Holds 8 chef 's knives, 2 smaller knives, 1 steel and scissors.** – Per 8 coltelli cuoco, 2 coltelli piccoli, 1 acciaio e forbici.



**Knife rack**

Porta coltelli  
Messeraufhänger  
Support à couteaux  
Porta cuchillos

| art.     | cm.           |
|----------|---------------|
| 48040-10 | 30,5x6,6x35,6 |

**Holds 8 chef 's knives, 2 smaller knives, 1 steel and scissors.** – Per 8 coltelli cuoco, 2 coltelli piccoli, 1 acciaio e forbici.



**Knife rack**

Porta coltelli  
Messeraufhänger  
Support à couteaux  
Porta cuchillos

| art.     | cm.           |
|----------|---------------|
| 48039-06 | 15,2x6,6x30,5 |

**Holds 1 cleaver and 4 chef knives or 6 chef knives or 8 slicers or 12 paring knives and 1 round or diamond steel.** – Per 1 mannaia e 4 coltelli cuoco o 6 coltelli cuoco o 8 coltelli affettare o 12 spelucchini e 1 acciaio tondo.



**Knife sanitizing system**

Sterilizzatore ad immersione  
Messerkemmer  
Stérilisateur à couteaux  
Esterilizador a inmersión

| art.     | cm.            |
|----------|----------------|
| 48040-50 | 45,7x11,5x45,7 |



**Manual sharpener**

Affilacoltelli manuale  
Messer Schleifapparat  
Affûteur manuel  
Afilador manual

| art.     |
|----------|
| 18255-00 |



**Manual sharpener**

Affilacoltelli manuale  
Messer Schleifapparat  
Affûteur manuel  
Afilador manual

| art.     |
|----------|
| 49739-00 |



**Salami pricker**

Pungisalame  
Salamistachel  
Pique saucisson  
Picadura para embutido

| art.     |
|----------|
| 42523-00 |



SS

**Larding needle with flap**

Ago lardellare con becco  
Spicknadel mit Klappe  
Lardoire à clapet  
Aguja para mechar

| art.     | Ø mm. | cm. |
|----------|-------|-----|
| 42514-20 | 5     | 20  |



SS

**Trussing needle straight**

Ago da cucina  
Dressiernadel  
Aiguille à brider droite  
Aguja para bridar

| art.     | cm. |
|----------|-----|
| 42515-18 | 18  |
| 42515-20 | 20  |



SS

**Trussing needle bent**

Ago da cucina curvo  
Dressiernadel gebogen  
Aiguille à brider courbe  
Aguja curva para bridar

| art.     | cm. |
|----------|-----|
| 42516-18 | 18  |
| 42516-20 | 20  |



SS

**Needles 5 pcs set**

Aghi set 5 pz  
Nadelsatz, 5 Stk.  
Aiguilles set 5 pcs  
Agujas 5 pz

| art.     |
|----------|
| 42517-06 |



W

**Skewers, 100 pcs**

Spiedini, 100 pz  
Fleischspieße, 100 Stk  
Brochettes, 100 pcs  
Palos para asar, 100 pz

| art.     | cm. |
|----------|-----|
| 48307-01 | 15  |
| 48307-02 | 20  |
| 48307-03 | 25  |



SS

**Skewers 6 pcs set**

Spiedini set 6 pz  
Fleischspieße, Satz 6 Stk  
Brochettes set 6 pcs  
Palos para asar 6 pz

| art.     | cm. |
|----------|-----|
| 42529-06 | 30  |



**Skewers falt, 18/8**

Spiedini piatti, 18/8  
Fleischspieße, flach, 18/8  
Brochettes plates, 18/8  
Pinchos planos, 18/8

| art.     | mm.   | U. Pack |
|----------|-------|---------|
| 42511-20 | 200x3 | 10      |
| 42511-25 | 250x3 | 10      |
| 42511-30 | 300x3 | 10      |
| 42511-35 | 350x3 | 10      |
| 42511-40 | 400x3 | 10      |
| 42511-56 | 560x5 | 10      |



**Swords, 18/8**

Spade, 18/8  
Schwörter, 18/8  
Espées, 18/8  
Espadas, 18/8

| art.     | mm.      |
|----------|----------|
| 42511-60 | 600x15x3 |
| 42511-70 | 700x15x3 |



SS

**Anchor meat hook**

Gancio ad ancora  
Anker Fleischhaken  
Esse à ancre  
Gancho forma ancla

| art.     | Ø mm. | cm. | U. Pack |
|----------|-------|-----|---------|
| 42507-12 | 7     | 13  | 10      |



SS

**Sliving meat hook**

Gancio girevole  
Fleischdrehhaken  
Esse-tournante  
Gancho giratorio

| art.     | Ø mm. | cm. | U. Pack |
|----------|-------|-----|---------|
| 42525-27 | 12    | 27  | 10      |



SS

**Meat hook, 2 peacks**

Gancio fisso, 2 punte  
Fleischhaken, 2 Spitze  
Crochet esse, 2 pointes  
Gancho 2 puntas

| art.     | Ø mm. | cm. | U. Pack |
|----------|-------|-----|---------|
| 42524-06 | 3     | 6   | 10      |
| 42524-08 | 4     | 8   | 10      |
| 42524-10 | 4     | 10  | 10      |
| 42524-12 | 5     | 12  | 10      |
| 42524-14 | 5     | 14  | 10      |
| 42524-16 | 6     | 16  | 10      |
| 42524-18 | 6     | 18  | 10      |
| 42524-20 | 9     | 20  | 10      |
| 42524-22 | 9     | 22  | 10      |
| 42524-30 | 12    | 30  | 10      |



SS

**Meat hook, 1 peack**

Gancio fisso, 1 punta  
Fleischhaken, 1 Spitze  
Crochet esse, 1 pointe  
Gancho 1 punta

| art.     | Ø mm. | cm. | U. Pack |
|----------|-------|-----|---------|
| 42506-08 | 3     | 8   | 10      |
| 42506-10 | 4     | 10  | 10      |
| 42506-12 | 5     | 12  | 10      |
| 42506-14 | 5     | 14  | 10      |
| 42506-16 | 6     | 16  | 10      |
| 42506-18 | 6     | 18  | 10      |



SS

**Swivel meat hook**

Gancio girevole  
Fleischdrehhaken  
Esse-tournante  
Gancho giratorio

| art.     | Ø mm. | cm. |
|----------|-------|-----|
| 42505-21 | 9     | 22  |
| 42505-24 | 10    | 24  |
| 42505-27 | 12    | 27  |
| 42505-50 | 12    | 50  |



SS

**Sliding meat hook**

Gancio scorrevole  
Fleischhaken  
Crochet coulissant  
Gancho

| art.     | Ø mm. | cm. | U. Pack |
|----------|-------|-----|---------|
| 42526-12 | 9     | 12  | 10      |
| 42526-14 | 12    | 14  | 10      |



SS

**Ham tongs**

Pinza per affettati  
Schinkenzange  
Pince à jambon  
Pinza para jamón

| art.     | cm.  |
|----------|------|
| 42510-00 | 11x6 |



SS

**Meat tenderizer**

Batticarne a pugno  
Kotelettklopfen  
Aplatisseur  
Aplasta carnes

| art.     | Kg. |
|----------|-----|
| 42501-15 | 1,5 |
| 42501-20 | 2,0 |



SS

**Meat tenderizer**

Batticarne a due tagli  
Kotelettklopfen  
Aplatisseur  
Aplasta carnes

| art.     | Kg. |
|----------|-----|
| 42502-11 | 1,1 |



SS

**Meat tenderizer**

Batticarne a paletta  
Kotelettklopfen  
Aplatisseur  
Aplasta carnes

| art.     | Kg. |
|----------|-----|
| 42503-10 | 1   |





**Steak hammer, aluminum**

Batticarne, alluminio  
Aluminum-Fleischklopfer  
Attendrisseur, alu  
Aplasta carnes, aluminio

| art.     | cm. | Kg. |
|----------|-----|-----|
| 42508-00 | 32  | 0,6 |



**Steak hammer, aluminum**

Batticarne, alluminio  
Aluminum-Fleischklopfer  
Attendrisseur, alu  
Aplasta carnes, aluminio

| art.     | cm. | Kg.  |
|----------|-----|------|
| 42508-01 | 25  | 0,41 |



SS

**Bone-saw**

Sega per ossa  
Knochensäge  
Scie à os  
Sierra de cocina

| art.     | cm. |
|----------|-----|
| 48231-40 | 40  |
| 48231-45 | 45  |
| 48231-50 | 50  |



SS

**String holder**

Portaspago  
Schnurrolle-Halter  
Porte rolls sur socle  
Porta cuerda

| art.     | cm.      |
|----------|----------|
| 42579-00 | 19x12x17 |



SS

**Meat pan**

Vassoio rettangolare  
Fleischblech  
Plat boucher  
Bandeja rectangular

| art.     | cm.     |
|----------|---------|
| 42534-26 | 26x23x2 |
| 42534-32 | 34x21x2 |
| 42534-41 | 45x25x2 |



SS

**Display tray**

Vassoio espositore  
Ausstellplatte  
Plateau  
Bandeja expositora

| art.     | cm.     |
|----------|---------|
| 42532-29 | 29x21x2 |
| 42532-58 | 58x21x2 |



SS

**Meat pan**

Vassoio  
Fleischblech  
Plat boucher  
Contenedor

| art.     | cm.           |
|----------|---------------|
| 42530-26 | 24,4x21,6x5,5 |
| 42530-32 | 32x23x5,5     |
| 42530-41 | 41x31x5,5     |
| 42530-50 | 50x35x5,5     |



SS

**Meat pan with grid**

Vassoio con griglia  
Fleischblech mit Siebeinsatz  
Plat boucher avec grille  
Contenedor con rejilla

| art.     | cm.           |
|----------|---------------|
| 42531-26 | 24,4x21,6x5,5 |
| 42531-32 | 32x23x5,5     |
| 42531-41 | 41x31x5,5     |
| 42531-50 | 50x35x5,5     |



**Ham stand on wood**

Ferma prosciutto base legno  
Schinkenhalter, Holzsockel  
Pince à jambon sur bois  
Jamoneiro, base madera

| art.     | cm.      | Kg. |
|----------|----------|-----|
| 41582-00 | 24x45x16 | 4,5 |



**Ham stand on marble**

Ferma prosciutto base marmo  
Schinkenhalter, Marmorsockel  
Pince à jambon sur marbre  
Jamoneiro, base mármol

| art.     | cm.      | Kg.  |
|----------|----------|------|
| 41583-00 | 24x45x15 | 10,3 |



SS

**Hamburger press**

Pressa-hamburger  
Hamburgerpresse  
Moule à steak  
Prensa para hamburguesa

| art.     | Ø cm. | l. cm. |
|----------|-------|--------|
| 42864-10 | 10    | 36     |



**Hamburger press, anodized aluminum**

Pressa-hamburger, alluminio anodizzato  
Hamburgerpresse, Aluminium eloxiert  
Moule à steak, aluminium anodisé  
Prensa para hamburguesa, aluminio anodizado

| art.     | cm.        | Kg. |
|----------|------------|-----|
| 49978-10 | 37x25x50   | 5,0 |
| 49978-13 | 42x27,5x53 | 5,5 |

**The parts coming into contact with food are in stainless steel. – Parti a contatto con il cibo in acciaio inox per alimenti.**



**Vertical manual sausage filler**

Insacatrice verticale  
Wurstfüller  
Poussoir manuel vertical  
Enscadora vertical

| art.     | cm.        | lt. | Kg. |
|----------|------------|-----|-----|
| 49876-03 | 30x22x47,5 | 3   | 6,2 |

**With 3 funnels. – Con 3 imbuti.**



**Manual slicing machine - Flywheel**

Affettatrice manuale - Volano  
Aufschnittmaschine - Schwungrad  
Trancheuse manuelle - Volant  
Cortadora manual - Volante

| art.     | Ø cm. | cm.      | Kg. |
|----------|-------|----------|-----|
| 49971-25 | 25    | 68x52x51 | 33  |

**Cut thickness range mm 0÷2,3. 9 cutting positions. Cut cm 18,5x51. – Spessore taglio mm. 0÷2,3. 8 scatti. Taglio utile cm 18,5x15.**



**Manual slicing machine - Flywheel**

Affettatrice manuale - Volano  
Aufschnittmaschine - Schwungrad  
Trancheuse manuelle - Volant  
Cortadora manual - Volante

| art.     | Ø cm. | cm.      | Kg.  |
|----------|-------|----------|------|
| 49972-30 | 30    | 72x60x74 | 45,5 |

**Cut thickness range mm 0÷2,5. 9 cutting positions. Cut cm 23x19. – Spessore taglio mm. 0÷2,5. 9 scatti. Taglio utile cm 23x19.**



**Manual slicing machine - Flywheel**

Affettatrice manuale - Volano  
Aufschnittmaschine - Schwungrad  
Trancheuse manuelle - Volant  
Cortadora manual - Volante

| art.     | Ø cm. | des.  |
|----------|-------|-------|
| 49971R25 | 25    | Rose  |
| 49971M25 | 25    | Daisy |
| 49972R30 | 30    | Rose  |
| 49972M30 | 30    | Daisy |



**Stand**

Piedistallo  
Sockel  
Piédestal  
Pedestal

| art.     | cm.   |
|----------|-------|
| 49971P25 | 65x80 |
| 49972P30 | 65x80 |



**Stand with wheels**

Piedistallo con ruote  
Sockel mit Rädern  
Piédestal avec roues  
Pedestal con ruedas

| art.     | cm.   |
|----------|-------|
| 49971R00 | 65x80 |



**Block brush, plastic handle**

Spazzola per ceppe  
Blockbürste, Kunststoffgriff  
Brosse à billot, matière plastique  
Cepillo para cepa

| art.     | cm. |
|----------|-----|
| 42518-01 | 20  |



PE

**Cutting board with tray**

Tagliere con vasca  
Tranchierbrett mit Tablett  
Planche à découper avec plateau  
Tabla de corte con bandeja

| art.     | cm.         |
|----------|-------------|
| 44947-00 | 33,5x46x5,5 |

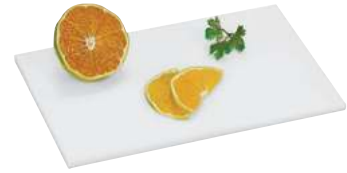

HDPE

**Cutting board**

Tagliere bar  
Tranchierbrett  
Planche à découper  
Tabla de corte

| art.     | cm.         |
|----------|-------------|
| 42521-16 | 16x24,5x1   |
| 42521-24 | 24,5x32,5x1 |



**03 = RED / ROSSO**  
Raw meat and poultry  
Carni crude  
Rohes Fleisch  
Viande crue  
Carne cruda



**02 = BROWN / MARRONE**  
Raw vegetables  
Verdure crude  
Rohes Gemüse  
Crudités  
Verduras crudas



**04 = BLUE / BLU**  
Raw fish  
Pesce  
Fisch  
Poisson  
Pescado



**01 = YELLOW / GIALLO**  
Cooked meats  
Carni cotte  
Gekochtes Fleisch  
Viande cuite  
Carne cocida



**05 = GREEN / VERDE**  
Salads and fruits  
Insalata e frutta  
Salat und Früchte  
Salade et fruits  
Ensalada y fruta



**00 = WHITE / BIANCO**  
Bakery and dairy products  
Pane e formaggi  
Brot und Käse  
Pain et fromages  
Pan y quesos



**07 = VIOLA / VIOLET**  
Gluten Free  
Casher  
Hallal  
Vegan



HDPE

**Cutting board**

Tagliere bar  
Tranchierbrett  
Planche à découper  
Tabla de corte

| art.     | cm.       | GN  | col. |
|----------|-----------|-----|------|
| 42522-00 | 32x26,5x2 | 1/2 | ○    |
| 42522-01 | 32x26,5x2 | 1/2 | ●    |
| 42522-02 | 32x26,5x2 | 1/2 | ●    |
| 42522-03 | 32x26,5x2 | 1/2 | ●    |
| 42522-04 | 32x26,5x2 | 1/2 | ●    |
| 42522-05 | 32x26,5x2 | 1/2 | ●    |
| 42522-09 | 32x26,5x2 | 1/2 | ●    |



HDPE

**Cutting board**

Tagliere bar  
Tranchierbrett  
Planche à découper  
Tabla de corte

| art.     | cm.       | GN  | col. |
|----------|-----------|-----|------|
| 42538-00 | 53x32,5x2 | 1/1 | ○    |
| 42538-01 | 53x32,5x2 | 1/1 | ●    |
| 42538-02 | 53x32,5x2 | 1/1 | ●    |
| 42538-03 | 53x32,5x2 | 1/1 | ●    |
| 42538-04 | 53x32,5x2 | 1/1 | ●    |
| 42538-05 | 53x32,5x2 | 1/1 | ●    |
| 42538-09 | 53x32,5x2 | 1/1 | ●    |



HDPE

**Cutting board**

Tagliere bar  
Tranchierbrett  
Planche à découper  
Tabla de corte

| art.     | cm.     | col. |
|----------|---------|------|
| 42539-00 | 60x40x2 | ○    |
| 42539-01 | 60x40x2 | ●    |
| 42539-02 | 60x40x2 | ●    |
| 42539-03 | 60x40x2 | ●    |
| 42539-04 | 60x40x2 | ●    |
| 42539-05 | 60x40x2 | ●    |
| 42539-09 | 60x40x2 | ●    |



HDPE

**Cutting board**

Tagliere bar  
Tranchierbrett  
Planche à découper  
Tabla de corte

| art.     | cm.       |
|----------|-----------|
| 42522-07 | 32x26,5x2 |
| 42538-07 | 53x32,5x2 |
| 42539-07 | 60x40x2   |



HDPE

**Cutting board**

Tagliere bar  
Tranchierbrett  
Planche à découper  
Tabla de corte

| art.     | cm.     |
|----------|---------|
| 42537-40 | 40x30x2 |
| 42537-50 | 50x30x2 |
| 42537-80 | 80x40x2 |



HDPE

**Cutting board with groove**

Tagliere con canalina  
Tranchierbrett mit Kanal  
Planche à découper avec rigole  
Tabla de corte con ranura

| art.     | cm.     | GN  | col. |
|----------|---------|-----|------|
| 42546-00 | 65x53x2 | 2/1 | ○    |
| 42546-01 | 65x53x2 | 2/1 | ●    |
| 42546-02 | 65x53x2 | 2/1 | ●    |
| 42546-03 | 65x53x2 | 2/1 | ●    |
| 42546-04 | 65x53x2 | 2/1 | ●    |
| 42546-05 | 65x53x2 | 2/1 | ●    |



HDPE

**Cutting board with stoppers**

Tagliere con fermi  
Tranchierbrett mit Stiften  
Planche à découper avec arrêts  
Tabla de corte con barras de la parada

| art.     | cm.       | GN  | col. |
|----------|-----------|-----|------|
| 42543-00 | 53x32,5x2 | 1/1 | ○    |
| 42543-01 | 53x32,5x2 | 1/1 | ●    |
| 42543-02 | 53x32,5x2 | 1/1 | ●    |
| 42543-03 | 53x32,5x2 | 1/1 | ●    |
| 42543-04 | 53x32,5x2 | 1/1 | ●    |
| 42543-05 | 53x32,5x2 | 1/1 | ●    |



HDPE

**Cutting board with stoppers**

Tagliere con fermi  
Tranchierbrett mit Stiften  
Planche à découper avec arrêts  
Tabla de corte con barras de la parada

| art.     | cm.     | col. |
|----------|---------|------|
| 42544-00 | 60x40x2 | ○    |
| 42544-01 | 60x40x2 | ●    |
| 42544-02 | 60x40x2 | ●    |
| 42544-03 | 60x40x2 | ●    |
| 42544-04 | 60x40x2 | ●    |
| 42544-05 | 60x40x2 | ●    |



HDPE

**Cutting board with stoppers**

Tagliere con fermi  
Tranchierbrett mit Stiften  
Planche à découper avec arrêts  
Tabla de corte con barras de la parada

| art.     | cm.     |
|----------|---------|
| 42540-40 | 40x30x2 |
| 42540-50 | 50x30x2 |
| 42540-80 | 80x40x2 |



HDPE

**Colored cutting boards set 6 pcs**

Taglieri colorati set 6 pz  
Tranchierbretter 6 Stk.  
Planches à découper set 6 pcs  
Juego 6 tablas de corte

| art.     | cm.       |
|----------|-----------|
| 42541-06 | 46x31x1,3 |



HDPE

**Round cutting board**

Tagliere tondo  
Tranchierbrett, rund  
Planche à découper, ronde  
Tabla de corte redonda

| art.     | Ø cm. | h. cm. |
|----------|-------|--------|
| 42535-24 | 24,0  | 1,0    |
| 42535-32 | 32,5  | 1,5    |
| 42535-49 | 49,0  | 1,5    |



HDPE

**Butchers table**

Ceppa  
Hackblock  
Billot  
Cepa

| art.     | cm.      | mm. |
|----------|----------|-----|
| 42518-50 | 50x50x86 | 4*  |

\*Thickness. – Spessore.





HDPE

**Worktop**  
Ceppo  
Arbeitsplatte  
Plan de travail  
Encimera

art. cm. mm.  
42519-01 50x50 4\*

\*Thickness. – Spessore.



HDPE

**Board scraper**  
Raschietto  
Blockschäber  
Racloir à planches  
Rascador

art. cm.  
42520-00 17x6x9

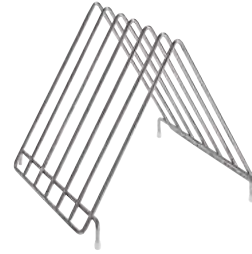

SS

**Cutting board rack**  
Portataglieri in filo  
Tranchierbretter-Träger  
Sechoir à plaques à découper  
Porta tablas

art. cm.  
42542-00 30x26x27,5



W

**Bread cutting board**  
Tagliere pane  
Brotschneidbrett  
Planche à découper  
Tabla de corte

art. cm.  
42964-53 53x32,5x2  
42964-60 60x40x2



CE  
SS

**Chainmail glove**  
Guanto in cotta di maglia  
Fingerhandschuhe  
Gant en cotte de mailles  
Guante de malla

art. size/T. col.  
48505-01 Small ○  
48505-02 Medium ●  
48505-03 Large ●

**UNI EN 1082-1:1998. Fits either hands, rings ø 4 mm. Thickness ø 0,5 mm. nylon strap.**  
Ambidestro, anelli ø 4 mm. Spessore ø 0,5 mm. cinturino nylon.



CE  
SS

**Chainmail glove, extended cuff**  
Guanto lungo in cotta di maglia  
Fingerhandschuhe, lang  
Gant en cotte de mailles, manchette longue  
Guante largo de malla

art. size/T. col.  
48506-01 Small ○  
48506-02 Medium ●  
48506-03 Large ●

**UNI EN 1082-1:1998. Fits either hands, rings ø 4 mm. Thickness ø 0,5 mm. nylon strap.**  
Ambidestro, anelli ø 4 mm. Spessore ø 0,5 mm. cinturino nylon.



CE  
SS

**Protective apron**  
Grembiule di protezione  
Schutzschürze  
Tablier de protection  
Delantal de protección

art. cm.  
48501-76 75x55

**UNI EN 1082-1:1998. Belt fastening with textile adjustable and detachable straps. – Dotato di bretelle regolabili e staccabili.**



**Oven mitt**  
Guanto da forno  
Ofenhandschuh  
Moufle de déformement  
Manopla de protección

art. l. cm.  
48510-00 28

**Outer fabric 100% cotton with silver coating, 100 g/mq. – Tessuto esterno 100% cotone con rivestimento argenteo 100 g/mq.**



**Oven mitt, silicone**  
Guanto da forno, silicone  
Backhandschuhe, Silikon  
Gant de protection, silicone  
Manopla de protección, silicona

art.  
48514-00

**Ambidextrous. Contact heat resistant up to +300°C for 15 seconds. Non-slip, water and oil tight, dishwasher safe. – Ambidestro. Resistenza al calore per contatto fino a 300°C per 15 secondi. Stagno all'acqua e agli oli bollenti, lavabile in lavastoviglie.**



**Cut resistant glove**

Guanto anti taglio  
Schnittschutz-Handschuh  
Gant anti-coupures  
Guante de protección

art. size/T.

48523-01 S

48523-02 M

48523-03 L

48523-04 XL

**Spectra fiber glove, cut resistance std EN388: level 5, washable up to 90°C, ambidextrous. Supplied with cotton underglove.** – Guanto in fibra spectra, resistenza al taglio std EN388: livello 5, lavabile fino a 90°C, ambidestro. Fornito con sottoguanto in cotone.



**Three-finger oven glove**

Guanti anticalore a 3 dita  
Backhandschuhe, 3 Finger  
Moufles protection thermique, 3 doigts  
Guantes de protección

art. l. cm.

48517-03 35,5

**Resistant to abrasion, tears and cuts. CE marking, in accordance to the basic requirements concerning health and security of the European Directives 89/686/C.E.E. Contact heat resistant up to +350°C for 20 seconds.** – Resistenti all'abrasione, agli strappi ed ai tagli. Marcati CE, rispettano i requisiti essenziali di salute e sicurezza secondo le direttive europee 89/686/C.E.E. Hanno una resistenza al calore per contatto fino a 350°C per 20 secondi.



**Oven mitts**

Guanti da forno  
Backhandschuhe  
Moufles de défournement  
Manoplas de protección

art. cm.

48511-02 34x16

**Special cotton fabric, natural color, reinforced palm and thumb. Heat resistant up to +200°C. Machine washable up to +40°C.** – In cotone speciale, colore naturale, esecuzione rinforzata palmo e pollice. Resistente fino a +200°C. Lavabile in lavatrice max. 40°C.



**Oven mitts**

Guanti da forno  
Backhandschuhe  
Moufles de défournement  
Manoplas de protección

art. cm.

48513-02 26x14,5

**Special cotton fabric, natural color, reinforced palm and thumb. Heat resistant up to +200°C. Machine washable up to +40°C.** – In cotone speciale, colore naturale, esecuzione rinforzata palmo e pollice. Resistente fino a +200°C. Lavabile in lavatrice max. 40°C.



**Oven mitts**

Guanti da forno  
Backhandschuhe  
Moufles de défournement  
Manoplas de protección

art. cm.

48512-02 27x15

**Special cotton fabric, natural color, reinforced palm and thumb. Heat resistant up to +200°C. Machine washable up to +40°C.** – In cotone speciale, colore naturale, esecuzione rinforzata palmo e pollice. Resistente fino a +200°C. Lavabile in lavatrice max. 40°C.



**Sugar gloves**

Guanti in lattice  
Zucker-Handschuhe  
Gants à tirer le sucre  
Guantes de látex

art. size/T.

48516-07 7 – 7 1/2

48516-08 8 – 8 1/2

48516-09 9 – 9/1/2



**Scrubbing gloves**

Guanti scrub  
Schrubben Handschuhe  
Gants à scrubbing  
Guantes para fregar

art. size/T.

48518-01 one size



**Scrubbing gloves**

Guanti scrub  
Schrubben Handschuhe  
Gants à scrubbing  
Guantes para fregar

art. size/T.

48518-02 one size

# PASTRY PASTICCERIA

EQUIPMENT  
ATTREZZATURE







**Alphabet pcs 26**

Alfabeto pz 26

| art.     | Ø cm. | h. cm. |
|----------|-------|--------|
| 47301-12 | 12    | 2      |



**Numbers pcs 10**

Numeri pz 10

| art.     | Ø cm. | h. cm. |
|----------|-------|--------|
| 47302-10 | 10    | 2      |



**Animals pcs 10**

Animali pz 10

| art.     | Ø cm. | h. cm. |
|----------|-------|--------|
| 47303-10 | 10    | 2      |

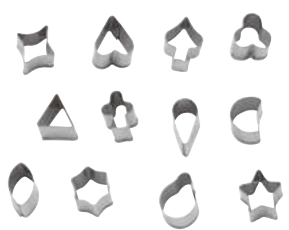

**Shapes pcs 12**

Sagome pz 12

| art.     | Ø cm. | h. cm. |
|----------|-------|--------|
| 47304-06 | 6,5   | 2      |

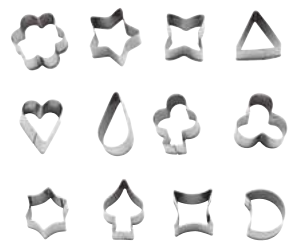

**Shapes pcs 12**

Sagome pz 12

| art.     | Ø cm. | h. cm. |
|----------|-------|--------|
| 47304-10 | 10    | 2      |



**Shapes pcs 12**

Sagome pz 12

| art.     | Ø cm. | h. cm. |
|----------|-------|--------|
| 47304-12 | 12    | 2      |



**Shapes pcs 12**

Sagome pz 12

| art.     | Ø cm. | h. cm. |
|----------|-------|--------|
| 47305-12 | 12    | 2      |



**Flower pcs 6**

Fiore pz 6

| art.     | Ø cm. | h. cm. |
|----------|-------|--------|
| 47306-10 | 10    | 3      |



**Trio pcs 6**

Trio pz 6

| art.     | Ø cm. | h. cm. |
|----------|-------|--------|
| 47307-10 | 10    | 3      |



**Heart pcs 6**

Cuore pz 6

| art.     | Ø cm. | h. cm. |
|----------|-------|--------|
| 47308-10 | 10    | 3      |



**Star pcs 6**

Stella pz 6

| art.     | Ø cm. | h. cm. |
|----------|-------|--------|
| 47310-10 | 10    | 3      |



**Halfmoon pcs 6**

Mezzaluna pz 6

| art.     | Ø cm. | h. cm. |
|----------|-------|--------|
| 47312-10 | 10    | 3      |



**Hexagon pcs 6**

Esagono pz 6

| art.     | Ø cm. | h. cm. |
|----------|-------|--------|
| 47314-10 | 10    | 3      |



**Hexagon, fluted pcs 5**

Esagono festonato pz 5

| art.     | Ø cm. | h. cm. |
|----------|-------|--------|
| 47315-10 | 10    | 3,5    |



**Ring pcs 11**

Anello pz 11

| art.     | Ø cm. | h. cm. |
|----------|-------|--------|
| 47316-10 | 10    | 3      |



**Ring pcs 14**

Anello pz 14

| art.     | Ø cm. | h. cm. |
|----------|-------|--------|
| 47316-12 | 12    | 3      |



**Ring pcs 20**

Anello pz 20

| art.     | Ø cm. | h. cm. |
|----------|-------|--------|
| 47316-20 | 20    | 2,5    |



**Ring, fluted pcs 11**

Anello festonato pz 11

| art.     | Ø cm. | h. cm. |
|----------|-------|--------|
| 47317-10 | 10    | 3      |







**Ring, fluted pcs 14**  
Anello festonato pz 14

| art.     | Ø cm. | h. cm. |
|----------|-------|--------|
| 47317-12 | 12    | 3      |



**Drop pcs 6**  
Goccia pz 6

| art.     | Ø cm. | h. cm. |
|----------|-------|--------|
| 47321-12 | 12    | 3      |



**Drop, fluted pcs 5**  
Goccia festonata pz 5

| art.     | Ø cm. | h. cm. |
|----------|-------|--------|
| 47322-12 | 12,5  | 3,5    |



**Square pcs 6**  
Quadro pz 6

| art.     | Ø cm. | h. cm. |
|----------|-------|--------|
| 47323-12 | 12    | 3      |



**Square, fluted pcs 6**  
Quadro festonato pz 6

| art.     | Ø cm. | h. cm. |
|----------|-------|--------|
| 47324-12 | 12,5  | 3,5    |



**Oval pcs 9**  
Ovale pz 9

| art.     | Ø cm. | h. cm. |
|----------|-------|--------|
| 47326-10 | 10    | 3,5    |



**Oval, fluted pcs 9**  
Ovale festonato pz 9

| art.     | Ø cm. | h. cm. |
|----------|-------|--------|
| 47325-10 | 10    | 3,5    |



**Fruit pcs 12**  
Frutta pz 12

| art.     | Ø cm. | h. cm. |
|----------|-------|--------|
| 47327-12 | 12,5  | 2      |



**Animals pcs 10**  
Animali pz 10

| art.     | Ø cm. | h. cm. |
|----------|-------|--------|
| 47328-15 | 15    | 2      |



**Vehicles pcs 7**  
Veicoli pz 7

| art.     | Ø cm. | h. cm. |
|----------|-------|--------|
| 47331-15 | 15    | 2      |



**Vegetable pcs 12**  
Verdura pz 12

| art.     | Ø cm. | h. cm. |
|----------|-------|--------|
| 47332-12 | 12,5  | 2      |



**Christmas pcs 7**  
Natale pz 7

| art.     | Ø cm. | h. cm. |
|----------|-------|--------|
| 47333-15 | 15    | 2      |



**Easter pcs 6**  
Pasqua pz 6

| art.     | Ø cm. | h. cm. |
|----------|-------|--------|
| 47334-12 | 12,5  | 2      |

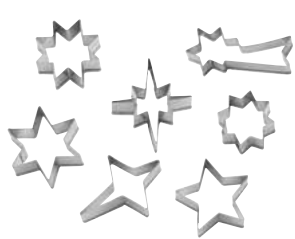

**Stars pcs 7**  
Stelle pz 7

| art.     | Ø cm. | h. cm. |
|----------|-------|--------|
| 47335-12 | 12,5  | 2      |



**Shapes pcs 10**  
Sagome pz 10

| art.     | Ø cm. | h. cm. |
|----------|-------|--------|
| 47419-10 | 20    | 3,5    |



**Shapes pcs 42**  
Sagome pz 42

| art.     | Ø cm. |
|----------|-------|
| 47336-42 | 6>22  |



**Plain ring pcs 3**  
Anello liscio pz 3

| art.     | Ø cm. | h. cm. |
|----------|-------|--------|
| 47414-03 | 6-7-8 | 3      |



**Fluted ring pcs 3**  
Anello festonato pz 3

| art.     | Ø cm. | h. cm. |
|----------|-------|--------|
| 47415-03 | 6-7-8 | 3      |



**Canestrello**  
Canestrello

| art.     | Ø cm. | h. cm. |
|----------|-------|--------|
| 47416-06 | 6     | 3      |



**Canestrello, fluted**  
Canestrello festonato

| art.     | Ø cm. | h. cm. |
|----------|-------|--------|
| 47417-06 | 6     | 3      |

CHRISTMAS  
NATALE



**Gingerbread man**  
Omino pan di zenzero  
art. cm.  
47370-08 6x8x3



**Angel**  
Angelo  
art. cm.  
47377-08 7x7x3



**Snowman**  
Pupazzo di neve  
art. cm.  
47378-08 4x8x3



**Reindeer**  
Renna  
art. cm.  
47379-08 8x7x3



**Star**  
Stella  
art. cm.  
47411-08 8x8x3



**Comet**  
Stella cometa  
art. cm.  
47412-08 8x4x3



**Christmas tree**  
Albero di Natale  
art. cm.  
47413-08 8x8x3



**Pine**  
Pino  
art. cm.  
47413-01 6,4x8x3

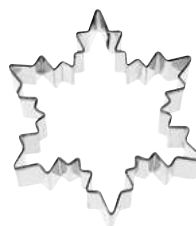

**Snowflake**  
Fiocco di neve  
art. cm.  
47411-01 7,4x8,6x3



**Snowflake**  
Fiocco di neve  
art. cm.  
47411-02 7x8x3







**Snowflake**  
Fiocco di neve

art. cm.  
47411-03 8,5x8x3



**Christmas, set of 6 pcs.**  
Natale set 6 pz

art. cm.  
47387-01 8x8x3



**EASTER**  
PASQUA



**Rabbit**  
Coniglio

art. cm.  
47372-08 8x4x3



**Rabbit**  
Coniglio

art. cm.  
47402-08 8x5x3



**Rabbit**  
Coniglio

art. cm.  
47402-01 7x8,5x3

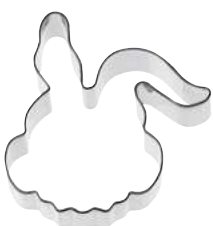

**Rabbit**  
Coniglio

art. cm.  
47402-02 7,5x7x3



**Bell**  
Campana

art. cm.  
47373-08 6x7x3



**Lamb**  
Agnellino

art. cm.  
47376-08 8x7x3



**Dove**

Colomba

art. cm.

47382-08 8x7x3



**Egg**

Uovo

art. cm.

47373-01 5,6x8x3



**Easter, set of 5 pcs.**

Pasqua set 5 pz

art. cm.

47387-02 8x8x3



## HALLOWEEN



**Skeleton**

Scheletro

art. cm.

47370-08 6x8x3



**Pumpkin**

Zucca

art. cm.

47377-09 9x8x3



**Pumpkin**

Zucca

art. cm.

47377-10 8x8x3



**Ghost**

Fantasma

art. cm.

47377-03 8x8,4x3



**Owl**

Gufo

art. cm.

47377-02 4,7x8,3x3







**Crescent**  
Mezzaluna

art. cm.  
47377-01 6,2x8x3



**Witch**  
Strega

art. cm.  
47377-04 9x9,5x3

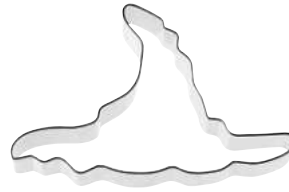

**Witch hat**  
Cappello strega

art. cm.  
47377-05 8,5x13x3



**Witch on broom**  
Strega su scopa

art. cm.  
47377-06 11,6x12x3



**Skull**  
Teschio

art. cm.  
47377-07 8x8x3

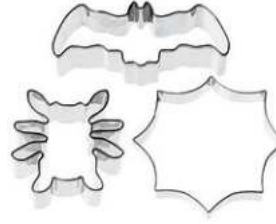

**Halloween, set of 3 pcs.**  
Halloween set 3 pz

art. cm.  
47377-11 11x10,7x2



**ANIMALS & VARIOUS**  
ANIMALI & VARI



**Honey bee**  
Ape

art. cm.  
47382-06 11,6x8x3

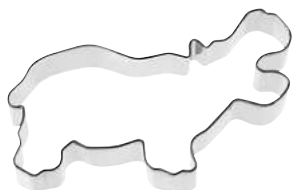

**Hippo**  
Ippopotamo

art. cm.  
47404-04 11x7x3



**Butterfly**  
Farfalla

art. cm.  
47371-08 8x7x3





**Snail**  
Lumaca  
art. cm.  
47404-02 11x6x3



**Fish**  
Pesce  
art. cm.  
47384-08 8x8x3



**Frog**  
Rana  
art. cm.  
47380-08 8x8x3



**Rooster**  
Gallo  
art. cm.  
47383-08 8x8x3

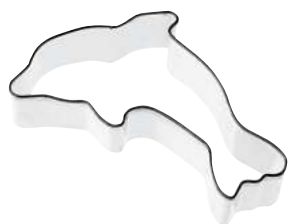

**Dolphin**  
Delfino  
art. cm.  
47384-01 5x9x3



**Seagull**  
Gabbiano  
art. cm.  
47386-08 11x6x3



**Cat**  
Gatto  
art. cm.  
47401-08 8x8x3



**Goose**  
Oca  
art. cm.  
47404-08 8x7x3



**Teddy bear**  
Orsetto  
art. cm.  
47375-08 8x8x3



**Camel**  
Cammello  
art. cm.  
47404-01 9x8,6x3



**Teddy bear**  
Orsetto  
art. cm.  
47375-01 6x9x3

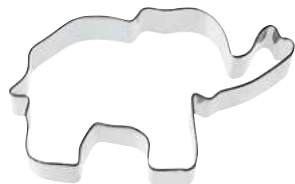

**Elephant**  
Elefante  
art. cm.  
47404-03 12x7x3



**Four leaf clover**  
Quadrifoglio  
art. cm.  
47374-08 8x8X3

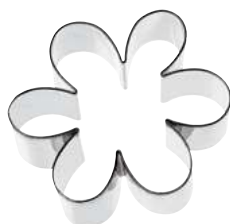

**Flower**  
Fiore  
art. cm.  
47374-02 7x7,4x3



**Tulip**  
Tulipano  
art. cm.  
47374-01 5,5x8x3







**Heart**

Cuore

art. cm.  
47385-08 8x9x3

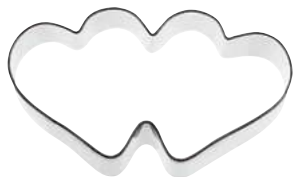

**Two hearts**

Due cuori

art. cm.  
47385-01 9,4x5x3



**Rocking horse**

Cavallo a dondolo

art. cm.  
47381-08 8x5x3



**Bow**

Fiocco

art. cm.  
47373-02 6x8x3



**Apple**

Mela

art. cm.  
47378-01 7,6x8,4x3



**Airplane**

Aereo

art. cm.  
47370-02 9x8x3



**Suits of cards, set of 4 pcs**

Semi carte set 4 pz

art. cm.  
47378-02 7,5x7,5x3



**Numbers, set of 9 pcs**

Numeri, set 9 pz

art. cm.  
47421-09 6,5x2,5

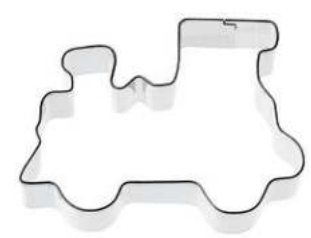

**Train**

Locomotiva

art. cm.  
47370-01 10x7x3



**Pirate ship**

Nave pirata

art. cm.  
47370-03 8x8,4x3



**Letters, set of 26 pcs**

Lettere, set 26 pz

art. cm.  
47422-26 6x2,5





**Round, set 6 pcs**  
Cerchio, set 6 pz

| art.     | cm. |
|----------|-----|
| 47425-01 | 4x3 |
| 47425-02 | 5x3 |
| 47425-03 | 6x3 |



**Square, set 6 pcs**  
Quadro, set 6 pz

| art.     | cm.   |
|----------|-------|
| 47425-04 | 5x5x3 |
| 47425-05 | 6x6x3 |



**Triangle, set 6 pcs**  
Triangolo, set 6 pz

| art.     | cm. |
|----------|-----|
| 47425-06 | 6x3 |



**Oval, set 6 pcs**  
Ovale, set 6 pz

| art.     | cm.       |
|----------|-----------|
| 47425-09 | 7,5x4,5x3 |



**Trapeze, set 6 pcs**  
Trapezio, set 6 pz

| art.     | cm.   |
|----------|-------|
| 47425-08 | 9x6x3 |



**Rectangle, set 6 pcs**  
Rettangolo, set 6 pz

| art.     | cm.     |
|----------|---------|
| 47425-10 | 5x3,5x3 |
| 47425-11 | 6x5x3   |



**Drop, set 6 pcs**  
Goccia, set 6 pz

| art.     | cm. |
|----------|-----|
| 47425-26 | 9x3 |



**Hexagon, set 6 pcs**  
Esagono, set 6 pz

| art.     | cm. |
|----------|-----|
| 47425-29 | 5x3 |
| 47425-30 | 6x3 |



**Heart, set 6 pcs**  
Cuore, set 6 pz

| art.     | cm.   |
|----------|-------|
| 47425-32 | 6,5x3 |



**Square, set 6 pcs**  
Quadro, set 6 pz

| art.     | cm.     |
|----------|---------|
| 47426-01 | 8x8x4,5 |



**Rectangle**  
Rettangolo

| art.     | cm.      |
|----------|----------|
| 47426-07 | 12x6x4,5 |



**Doughnut cutter**  
Tagliapasta per doughnuts  
Donut-Ausstecher  
Coupe-donuts  
Cortadonuts

| art.     | Ø cm. | h. cm. |
|----------|-------|--------|
| 47388-06 | 65-25 | 20     |
| 47388-07 | 70-30 | 17     |
| 47388-08 | 80-40 | 20     |



**Cinnamon star cutter**  
Tagliapaste stelle  
Zimtstern-Ausstecher  
Coupe-étoiles  
Cortapasta Esterella

| art.     | cm.   |
|----------|-------|
| 47377-15 | 5x9,7 |

**Spring mechanism. – Meccanismo a molla.**



**Horseshoe, tin plate**  
Ferro di cavallo, banda stagnata  
Hufeisen, Weißblech  
Fer à cheval, fer blanc  
Herradura, hojalata

| art.     | cm.   |
|----------|-------|
| 47377-12 | 7x6x2 |





CUTTERS  
TAGLIAPASTA



**Round fluted cutter, set 6 pcs**  
Tagliapasta rotondo festonato, set 6 pz  
Ausstecher, rund, gewellt, 6 Stk  
Découpoir rond cannelé, 6 pcs  
Cortapasta redondo acanalado, 6 pz

| art.     | Ø cm. | h. cm. |
|----------|-------|--------|
| 12944-13 | 3>12  | 3,5    |



**Oval fluted cutter, set 6 pcs**  
Tagliapasta ovale festonato, set 6 pz  
Ausstecher, oval, gewellt, 6 Stk  
Découpoir ovale cannelé, 6 pcs  
Cortapasta ovalado acanalado, 6 pz

| art.     | Ø cm.  | h. cm. |
|----------|--------|--------|
| 12947-13 | 5,5>13 | 3,5    |



**Round cutter**  
Tagliapasta rotondo  
Ausstecher, rund  
Découpoir rond  
Cortapasta redondo

| art.     | Ø cm. | h. cm. |
|----------|-------|--------|
| 12943-03 | 3     | 3,5    |
| 12943-05 | 5     | 3,5    |
| 12943-10 | 10    | 3,5    |
| 12943-12 | 12    | 3,5    |



**Round fluted cutter**  
Tagliapasta rotondo festonato  
Ausstecher, rund, gewellt  
Découpoir rond cannelé  
Cortapasta redondo acanalado

| art.     | Ø cm. | h. cm. |
|----------|-------|--------|
| 12944-03 | 3     | 3,5    |
| 12944-05 | 5     | 3,5    |
| 12944-07 | 7     | 3,5    |
| 12944-10 | 10    | 3,5    |



**Oval fluted cutter**  
Tagliapasta ovale festonato  
Ausstecher, oval, gewellt  
Découpoir ovale cannelé  
Cortapasta ovalado acanalado

| art.     | Ø cm.   | h. cm. |
|----------|---------|--------|
| 12947-02 | 5,5x3,5 | 3,5    |
| 12947-03 | 7x4     | 3,5    |
| 12947-04 | 8,5x5   | 3,5    |
| 12947-05 | 10x6    | 3,5    |
| 12947-06 | 11x7    | 3,5    |
| 12947-07 | 13x5    | 3,5    |



**Dough plunger cutters w/extractor, 3 pcs**  
Tagliapasta con espulsore, set 3 pz  
Ausstechformen mit Auswerfer, 3 Stk  
Emportes-pièces, 3 pcs  
Cortadores, 3 pz

| art.     | Ø cm. |
|----------|-------|
| 47622-04 | 3>4,5 |

Holly. – Agrifoglio.



**Dough plunger cutters w/extractor, 4 pcs**  
Tagliapasta con espulsore, set 4 pz  
Ausstechformen mit Auswerfer, 4 Stk  
Emportes-pièces, 4 pcs  
Cortadores, 4 pz

| art.     | Ø cm.               |
|----------|---------------------|
| 47622-26 | 1,2 - 2 - 2,8 - 3,5 |

Daisy. – Margherita.



**Dough plunger cutters w/extractor, 3 pcs**

Tagliapasta con espulsore, set 3 pz  
Ausstechformen mit Auswerfer, 3 Stk  
Emportes-pièces, 3 pcs  
Cortadores, 3 pz

art. Ø cm.

47622-01 3:5

**Petunie.** – Petunia.



**Dough plunger cutters w/extractor, 3 pcs**

Tagliapasta con espulsore, set 3 pz  
Ausstechformen mit Auswerfer, 3 Stk  
Emportes-pièces, 3 pcs  
Cortadores, 3 pz

art. Ø cm.

47622-02 2,5

**Flower.** – Fiore.



**Dough plunger cutters w/extractor, 3 pcs**

Tagliapasta con espulsore, set 3 pz  
Ausstechformen mit Auswerfer, 3 Stk  
Emportes-pièces, 3 pcs  
Cortadores, 3 pz

art. Ø cm.

47622-03 3:5

**Rose leaf.** – Foglia di rosa.



**SS**

**Set of 9 cutters**

Set 9 tagliapasta  
Satz 9 Ausstechformen  
Set 9 découpoirs  
Juego 9 cortadores

art. h. cm.

47837-09 0,5



**PA**

**Almond past knife**

Coltello per marzapane  
Marzipan-Messer  
Couteau à pâte d'amande  
Cuchillo para fondant/mazapán

art. l. cm.

47630-28 16,5



**PP**

**Marzipan set, 15 pcs**

Set 15 pezzi per marzapane  
Marzipan-Satz, 15 Stk.  
Set 15 outils à pâte d'amandes  
Set de 15 herramientas para decorar galletas

art.

47631-12



**PP**

**Marzipan set, 8 pcs**

Set 8 pezzi per marzapane  
Marzipan-Satz, 8 Stk.  
Set 8 outils à pâte d'amandes  
Set de 8 herramientas para decorar galletas

art.

47631-08



**SS**

**Set of 10 pcs dipping forks**

Set 10 forchettine pralineria  
Pralinen Gabelchen, 10 Stk.  
Jeu de 10 ébauchoirs  
Set de 10 herramientas para decorar chocolates

art.

47833-10



**SS**

**Set of 4 pcs dipping forks**

Set 4 forchettine pralineria  
Pralinen Gabelchen, 4 Stk.  
Jeu de 4 ébauchoirs  
Set de 4 herramientas para decorar chocolates

art.

47833-04



**SS**

**Set 2 decorating spoons**

Set 2 cucchiai decorazione  
Satz 2 Dekoration-Löffel  
Set 2 cuillères pour décorer  
2 cucharas para decoración

art. l. cm.

47831-02 19-23



**STAINLESS STEEL NOZZLES**  
**BOCCHETTE INOX**

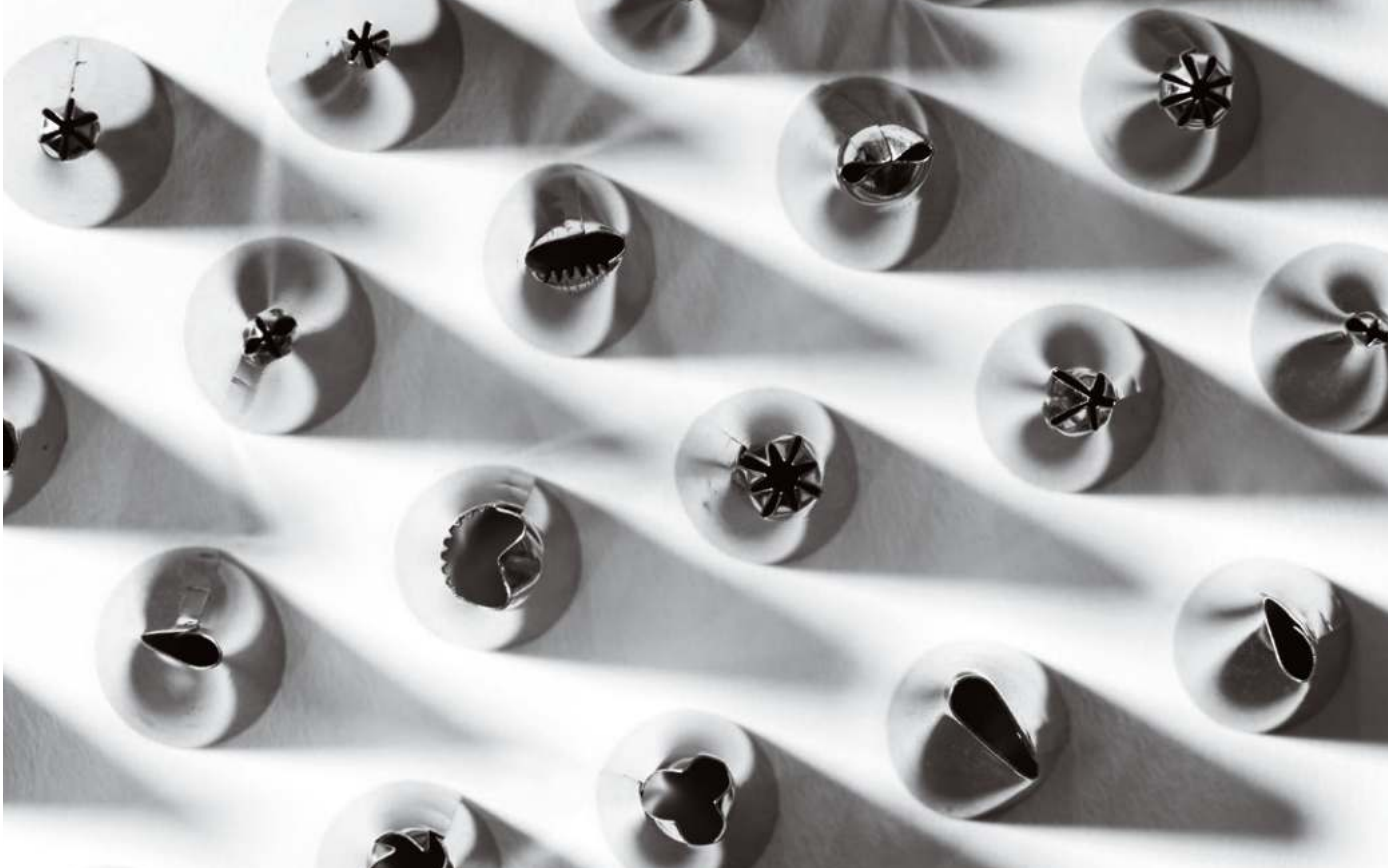

**Set 12 pcs, one piece nozzles**

Set 12 bocchette unipezzo  
Tüllen Set 12 Stk. aus einem Stück gezogen  
Set 12 pcs douilles monobloc  
Surtido 12 boquillas monobloc

| art.     | Ø mm.   | base ø mm. |
|----------|---|------------|
| 47357-20 | 1x 0,6-1,2-1,5-1,9-2,4-3<br>3,6-4,8-5,6-6,4-6,8-7,6 | 18         |

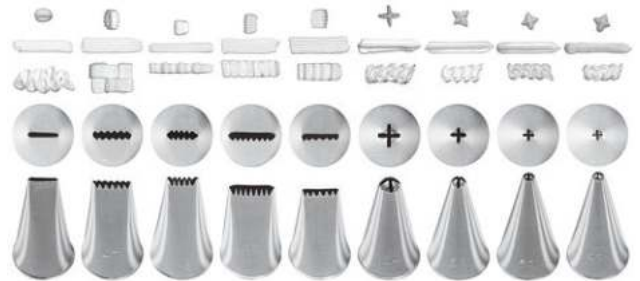

**Set 9 pcs, one piece nozzles**

Set 9 bocchette unipezzo  
Tüllen Set 9 Stk. aus einem Stück gezogen  
Set 9 pcs douilles monobloc  
Surtido 9 boquillas monobloc

| art.     | base ø mm. |
|----------|------------|
| 47357-24 | 18         |



**Set 7 pcs, one piece nozzles**

Set 7 bocchette unipezzo  
Tüllen Set 7 Stk. aus einem Stück gezogen  
Set 7 pcs douilles monobloc  
Surtido 7 boquillas monobloc

| art.     | Ø mm.                      | base ø mm. |
|----------|----------------------------|------------|
| 47357-21 | 1x 1,7-2,2-3,5-4,2-5-5,5-7 | 18         |



**Set 8 pcs, one piece nozzles**

Set 8 bocchette unipezzo  
Tüllen Set 8 Stk. aus einem Stück gezogen  
Set 8 pcs douilles monobloc  
Surtido 8 boquillas monobloc

| art.     | Ø mm.                        | base ø mm. |
|----------|------------------------------|------------|
| 47357-22 | 1x 1-1,5-1,8-2,6-3-3,4-2,5-7 | 18         |





**Set 8 pcs, one piece nozzles**  
Set 8 bocchette unipezzo  
Tüllen Set 8 Stk. aus einem Stück gezogen  
Set 8 pcs douilles monobloc  
Surtido 8 boquillas monobloc

---

| art.     | base ø mm. |
|----------|------------|
| 47357-28 | 18         |



**Set 8 pcs, one piece nozzles**  
Set 8 bocchette unipezzo  
Tüllen Set 8 Stk. aus einem Stück gezogen  
Set 8 pcs douilles monobloc  
Surtido 8 boquillas monobloc

---

| art.     | base ø mm. |
|----------|------------|
| 47357-29 | 18         |



**Set 8 pcs, one piece nozzles**  
Set 8 bocchette unipezzo  
Tüllen Set 8 Stk. aus einem Stück gezogen  
Set 8 pcs douilles monobloc  
Surtido 8 boquillas monobloc

---

| art.     | base ø mm. |
|----------|------------|
| 47357-30 | 18         |



**Set 8 pcs, one piece nozzles**  
Set 8 bocchette unipezzo  
Tüllen Set 8 Stk. aus einem Stück gezogen  
Set 8 pcs douilles monobloc  
Surtido 8 boquillas monobloc

---

| art.     | base ø mm. |
|----------|------------|
| 47357-31 | 18         |



**Set 6 pcs, one piece nozzles**  
Set 6 bocchette unipezzo  
Tüllen Set 6 Stk. aus einem Stück gezogen  
Set 6 pcs douilles monobloc  
Surtido 6 boquillas monobloc

---

| art.     | base ø mm. |
|----------|------------|
| 47357-06 | 25         |



**Set 6 pcs, one piece nozzles**  
Set 6 bocchette unipezzo  
Tüllen Set 6 Stk. aus einem Stück gezogen  
Set 6 pcs douilles monobloc  
Surtido 6 boquillas monobloc

---

| art.     | base ø mm. |
|----------|------------|
| 47357-07 | 25         |







**Set 6 pcs, one piece nozzles**

Set 6 bocchette unipezzo  
Tüllen Set 6 Stk. aus einem Stück gezogen  
Set 6 pcs douilles monobloc  
Surtido 6 boquillas monobloc

art. base ø mm.  
47357-08 25

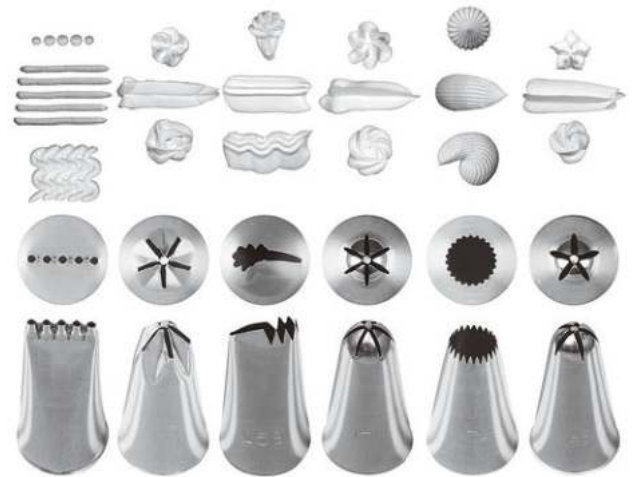

**Set 6 pcs, one piece nozzles**

Set 6 bocchette unipezzo  
Tüllen Set 6 Stk. aus einem Stück gezogen  
Set 6 pcs douilles monobloc  
Surtido 6 boquillas monobloc

art. base ø mm.  
47357-09 25



**Set 6 pcs, one piece nozzles**

Set 6 bocchette unipezzo  
Tüllen Set 6 Stk. aus einem Stück gezogen  
Set 6 pcs douilles monobloc  
Surtido 6 boquillas monobloc

art. base ø mm.  
47357-10 25



**Set 6 pcs, one piece nozzles**

Set 6 bocchette unipezzo  
Tüllen Set 6 Stk. aus einem Stück gezogen  
Set 6 pcs douilles monobloc  
Surtido 6 boquillas monobloc

art. base ø mm.  
47357-11 25



**Set 4 pcs, one piece nozzles**

Set 4 bocchette unipezzo  
Tüllen Set 4 Stk. aus einem Stück gezogen  
Set 4 pcs douilles monobloc  
Surtido 4 boquillas monobloc

art. base ø mm.  
47357-02 2x 31 - 2x 36



**Set 7 pcs, one piece nozzles**

Set 7 bocchette unipezzo  
Tüllen Set 7 Stk. aus einem Stück gezogen  
Set 7 pcs douilles monobloc  
Surtido 7 boquillas monobloc

art. base ø mm.  
47357-03 31



**Set 3x2 nozzles**

Set 3x2 bocchette  
3x2 Stk. Tüllen  
Set 3x2 pcs douilles  
Juego 3x2 boquillas

| art.     | Ø mm. | stars |
|----------|-------|-------|
| 47350-01 | 2x 25 | 6     |
|          | 2x 31 | 6     |
|          | 2x 36 | 6     |



**Set 3x2 nozzles**

Set 3x2 bocchette  
3x2 Stk. Tüllen  
Set 3x2 pcs douilles  
Juego 3x2 boquillas

| art.     | Ø mm. | stars |
|----------|-------|-------|
| 47351-01 | 2x 31 | 6     |
|          | 2x 31 | 8     |
|          | 2x 36 | 9     |



**Set 3x2 nozzles**

Set 3x2 bocchette  
3x2 Stk. Tüllen  
Set 3x2 pcs douilles  
Juego 3x2 boquillas

| art.     | Ø mm. | stars |
|----------|-------|-------|
| 47352-01 | 2x 31 | 6     |
|          | 2x 31 | 8     |
|          | 2x 36 | 9     |



**Set 6 pcs, one piece nozzles**

Set 6 bocchette unipezzo  
Tüllen Set 6 Stk. aus einem Stück gezogen  
Set 6 pcs douilles monobloc  
Surtido 6 boquillas monobloc

| art.     | Ø mm. | stars |
|----------|-------|-------|
| 47208-01 | 3,0   | 5     |
| 47208-02 | 3,0   | 6     |
| 47208-03 | 3,5   | 7     |
| 47208-04 | 5,0   | 8     |



**Set 6 pcs, one piece nozzles**

Set 6 bocchette unipezzo  
Tüllen Set 6 Stk. aus einem Stück gezogen  
Set 6 pcs douilles monobloc  
Surtido 6 boquillas monobloc

| art.     | Ø mm. | stars |
|----------|-------|-------|
| 47208-05 | 5     | 5     |
| 47208-06 | 5     | 6     |
| 47208-07 | 6     | 7     |
| 47208-08 | 7     | 8     |



**Set 6 pcs, one piece nozzles**

Set 6 bocchette unipezzo  
Tüllen Set 6 Stk. aus einem Stück gezogen  
Set 6 pcs douilles monobloc  
Surtido 6 boquillas monobloc

| art.     | Ø mm. | stars |
|----------|-------|-------|
| 47208-09 | 7     | 5     |
| 47208-10 | 7     | 6     |
| 47208-11 | 7     | 7     |
| 47208-12 | 9     | 8     |



**Set 6 pcs, one piece nozzles**

Set 6 bocchette unipezzo  
Tüllen Set 6 Stk. aus einem Stück gezogen  
Set 6 pcs douilles monobloc  
Surtido 6 boquillas monobloc

| art.     | Ø mm. | stars |
|----------|-------|-------|
| 47208-13 | 11    | 5     |
| 47208-14 | 11    | 6     |
| 47208-15 | 11    | 7     |
| 47208-16 | 11    | 8     |





**Set 6 pcs, one piece nozzles**

Set 6 bocchette unipezzo  
Tüllen Set 6 Stk. aus einem Stück gezogen  
Set 6 pcs douilles monobloc  
Surtido 6 boquillas monobloc

| art.     | Ø mm. | stars |
|----------|-------|-------|
| 47208-17 | 13    | 5     |
| 47208-18 | 13    | 6     |
| 47208-19 | 13    | 7     |
| 47208-20 | 13    | 8     |



**Set 6 pcs, one piece nozzles**

Set 6 bocchette unipezzo  
Tüllen Set 6 Stk. aus einem Stück gezogen  
Set 6 pcs douilles monobloc  
Surtido 6 boquillas monobloc

| art.     | Ø mm. | stars |
|----------|-------|-------|
| 47208-21 | 18    | 5     |
| 47208-22 | 18    | 6     |
| 47208-23 | 18    | 7     |
| 47208-24 | 18    | 8     |



**Set 6 pcs, one piece nozzles**

Set 6 bocchette unipezzo  
Tüllen Set 6 Stk. aus einem Stück gezogen  
Set 6 pcs douilles monobloc  
Surtido 6 boquillas monobloc

| art.     | Ø mm. | stars |
|----------|-------|-------|
| 47354-02 | 2     | 6     |
| 47354-04 | 4     | 6     |
| 47354-06 | 6     | 6     |
| 47354-08 | 8     | 6     |
| 47354-10 | 10    | 6     |
| 47354-12 | 12    | 7     |
| 47354-14 | 14    | 8     |
| 47354-16 | 16    | 9     |
| 47354-18 | 18    | 10    |



**Set 6 pcs, one piece nozzles**

Set 6 bocchette unipezzo  
Tüllen Set 6 Stk. aus einem Stück gezogen  
Set 6 pcs douilles monobloc  
Surtido 6 boquillas monobloc

| art.     | Ø mm. | stars |
|----------|-------|-------|
| 47355-02 | 2,5   | 6     |
| 47355-04 | 4,0   | 6     |
| 47355-06 | 6,0   | 6     |
| 47355-08 | 8,0   | 7     |
| 47355-10 | 10    | 8     |
| 47355-12 | 12    | 10    |



**Set 6 pcs, one piece nozzles**

Set 6 bocchette unipezzo  
Tüllen Set 6 Stk. aus einem Stück gezogen  
Set 6 pcs douilles monobloc  
Surtido 6 boquillas monobloc

| art.     | Ø mm. | stars |
|----------|-------|-------|
| 47356-02 | 2,0   | 5     |
| 47356-04 | 4,0   | 9     |
| 47356-06 | 5,5   | 9     |
| 47356-08 | 7,0   | 10    |
| 47356-10 | 8,5   | 12    |
| 47356-12 | 13,0  | 15    |
| 47356-14 | 14,5  | 16    |
| 47356-16 | 16,0  | 17    |
| 47356-18 | 17,5  | 18    |



**Set 6 pcs, one piece nozzles**

Set 6 bocchette unipezzo  
Tüllen Set 6 Stk. aus einem Stück gezogen  
Set 6 pcs douilles monobloc  
Surtido 6 boquillas monobloc

| art.     | Ø mm. |
|----------|-------|
| 47353-02 | 2     |
| 47353-04 | 4     |
| 47353-06 | 6     |
| 47353-08 | 8     |
| 47353-10 | 10    |
| 47353-12 | 12    |
| 47353-14 | 14    |
| 47353-16 | 16    |
| 47353-18 | 18    |
| 47353-20 | 20    |
| 47353-22 | 22    |
| 47353-24 | 24    |



**Set 6 pcs, one piece nozzles**

Set 6 bocchette unipezzo  
Tüllen Set 6 Stk. aus einem Stück gezogen  
Set 6 pcs douilles monobloc  
Surtido 6 boquillas monobloc

| art.     | Ø mm. |
|----------|-------|
| 47207-20 | 20    |
| 47207-25 | 25    |
| 47207-30 | 30    |



**Set 10 pcs Bismark nozzles**

Set 10 bocchette a imbuto  
Fülltüllen Set 10 Stk.  
Set 10 douilles à chou  
Surtido 10 boquillas para relleno

| art.     | Ø mm. | l. mm. |
|----------|-------|--------|
| 47127-04 | 4     | 90     |
| 47127-06 | 6     | 75     |
| 47127-08 | 8     | 90     |



**Nozzle**  
Bocchetta decorativa  
Spritztülle  
Douille  
Boquilla

| art.     | Ø mm. | h. cm. |
|----------|-------|--------|
| 47357-50 | 55    | 6      |



**Nozzle**  
Bocchetta decorativa  
Spritztülle  
Douille  
Boquilla

| art.     | Ø mm. | h. cm. |
|----------|-------|--------|
| 47357-51 | 55    | 5,6    |



**Nozzle**  
Bocchetta decorativa  
Spritztülle  
Douille  
Boquilla

| art.     | Ø mm. | h. cm. |
|----------|-------|--------|
| 47357-40 | 32    | 6,0    |



**Nozzle**  
Bocchetta decorativa  
Spritztülle  
Douille  
Boquilla

| art.     | Ø mm. | h. cm. |
|----------|-------|--------|
| 47357-41 | 32    | 5,7    |



**Nozzle**  
Bocchetta decorativa  
Spritztülle  
Douille  
Boquilla

| art.     | Ø mm. | h. cm. |
|----------|-------|--------|
| 47357-42 | 32    | 5,7    |



**Nozzle**  
Bocchetta decorativa  
Spritztülle  
Douille  
Boquilla

| art.     | Ø mm. | h. cm. |
|----------|-------|--------|
| 47357-43 | 32    | 5,7    |



**Nozzle**  
Bocchetta decorativa  
Spritztülle  
Douille  
Boquilla

| art.     | Ø mm. | h. cm. |
|----------|-------|--------|
| 47357-44 | 32    | 5,7    |



**Set of 6 nozzles**  
Set 6 bocchette  
Tüllen Set, 6 Stk  
Set 6 douilles  
Juego 6 boquillas

| art.     | Ø mm.          |
|----------|----------------|
| 47214-86 | 5-7-9-11-13-15 |

PP



**Set of 6 nozzles**  
Set 6 bocchette  
Tüllen Set, 6 Stk  
Set 6 douilles  
Juego 6 boquillas

| art.     | Ø mm.         |
|----------|---------------|
| 47215-86 | 3-5-7-9-11-13 |

PP



**Set of 12 nozzles**  
Set 12 bocchette  
Tüllen Set, 12 Stk  
Set 12 douilles  
Juego 12 boquillas

| art.     | Ø mm. |
|----------|-------|
| 47618-10 | 2·10  |
| 47618-20 | 10·20 |

PP



**Set of 12 nozzles**  
Set 12 bocchette  
Tüllen Set, 12 Stk  
Set 12 douilles  
Juego 12 boquillas

| art.     |
|----------|
| 47250-12 |

PC



**Set of 24 nozzles**  
Set 24 bocchette  
Tüllen Set, 24 Stk  
Set 24 douilles  
Juego 24 boquillas

| art.     |
|----------|
| 47250-24 |

PC





**Flower nozzles 12 pcs**  
Bocchette floreali 12 pz  
Spritztüllen 12 Stk  
Douille fleurs 12 pcs  
Boquillas florales 12 pz  
art.  
47357-38



**Set of 29 nozzles**  
Set 29 bocchette  
Tüllen Set, 29 Stk  
Set 29 douilles  
Juego 29 boquillas  
art.  
47219-29



**Set of 38 nozzles**  
Set 38 bocchette  
Tüllen Set, 38 Stk  
Set 38 douilles  
Juego 38 boquillas  
art.  
47219-38



**Set of 55 nozzles**  
Set 55 bocchette  
Tüllen Set, 55 Stk  
Set 55 douilles  
Juego 55 boquillas  
art.  
47219-55

**26 tubes, 2 flower nails, 1 standard coupler. – 26 bocchette, 2 chiodi per fiori, 1 adattatore standard.**



**External piping tip adapter**  
Adattatore per bocchette  
Adapter für Spritztüllen  
Adaptateur à douilles  
Adaptador para boquillas  
art.      Ø mm.      des.  
47212-01      18      STANDARD

**35 tubes, 1 medium coupler, 1 large coupler. – 35 bocchette, 1 adattatore medio, 1 grande.**



**External piping tip adapter**  
Adattatore per bocchette  
Adapter für Spritztüllen  
Adaptateur à douilles  
Adaptador para boquillas  
art.      Ø mm.      des.  
47212-02      25-31      MEDIUM

**52 tubes, 2 flower nails, 1 standard coupler. – 52 bocchette, 2 chiodi per fiori, 1 adattatore standard.**



**External piping tip adapter**  
Adattatore per bocchette  
Adapter für Spritztüllen  
Adaptateur à douilles  
Adaptador para boquillas  
art.      Ø mm.      des.  
47212-03      36      LARGE



**Nozzles adapter, 2 pcs**  
Adattatori per bocchette, 2 pz  
Spritztüllen-Adapter, 2 Stk  
Adaptateurs à douilles, 2 pièces  
Adaptadores boquillas, 2 piezas  
art.  
47212-05

**To prepare decorations with 2 or 3 colours. Suitable for piping tips base Ø 30 h 50 mm. Per decorazioni a 2 o 3 colori. Adatte a bocchette base Ø 30 h 50 mm.**



**Pastry tube brush, 6 pcs**  
Bruschino per bocchette, 6 pz  
Tüllen-Bürste, 6 Stk  
Brosse à douilles, 6 pcs  
Cepillo para boquillas, 6 pz  
art.      Ø cm.      l. cm.  
47200-01      0,8      10  
47200-02      0,5-2,4      12,5



**Cream roll molds, 10 pcs**

Cannoli, 10 pz  
Sahnerolle, konisch/gerade, 10 Stk  
Rouleau à fromage, 10 pcs  
Rodillos queso, 10 pz

| art.     | Ø mm. | l. mm. |
|----------|-------|--------|
| 47020-15 | 15    | 92     |
| 47020-20 | 22    | 142    |
| 47020-30 | 10-25 | 139    |
| 47020-35 | 20-25 | 171    |



**Cream horn molds, 10 pcs**

Cornetti, 10 pz  
Schillerlockenform, 10 Stk  
Moulet à cornet, 10 pcs  
Moldes para conos, 10 pz

| art.     | Ø mm. | l. mm. |
|----------|-------|--------|
| 47021-35 | 34    | 110    |
| 47021-45 | 47    | 161    |



**Decorating set 8 pcs**

Kit decoro 8 pezzi  
Dekorations-Set, 8-teilig  
Set 8 pcs à décorer  
Juego 8 piezas para decorar

| art.     |
|----------|
| 47120-01 |

**6 small tubes, 1 standard coupler, 1 bag cm. 35**  
6 bocchette piccole, 1 adattatore standard,  
1 sacchetto 35 cm.



**Decorating set 8 pcs**

Kit decoro 8 pezzi  
Dekorations-Set, 8-teilig  
Set 8 pcs à décorer  
Juego 8 piezas para decorar

| art.     |
|----------|
| 47120-02 |

**6 medium tubes, 1 medium coupler, 1 bag cm. 40.** – 6 bocchette medie, 1 adattatore medio, 1 sacchetto 40 cm.



**Icing bag**

Sacchetto per decorare  
Spritzbeutel  
Sac à dresser  
Mangas para decorar

| art.     | h. cm. | U. Pack |
|----------|--------|---------|
| 47106-28 | 28     | 6       |
| 47106-34 | 34     | 6       |
| 47106-40 | 40     | 6       |
| 47106-46 | 46     | 6       |
| 47106-50 | 50     | 6       |

**Synthetic fibre with multi-layer water-proof plastic coating.**



**Icing bag**

Sacchetto per decorare  
Spritzbeutel  
Sac à dresser  
Mangas para decorar

| art.     | h. cm. | U. Pack |
|----------|--------|---------|
| 47106-55 | 55     | 6       |
| 47106-60 | 60     | 6       |
| 47106-65 | 65     | 6       |
| 47106-70 | 70     | 6       |
| 47106-75 | 75     | 6       |

**Fibra sintetica con rivestimento a strati in plastica impermeabile.**



**Icing bag**

Sacchetto per decorare  
Spritzbeutel  
Sac à dresser  
Mangas para decorar

| art.     | h. cm. | U. Pack |
|----------|--------|---------|
| 47105-28 | 28     | 6       |
| 47105-34 | 34     | 6       |
| 47105-40 | 40     | 6       |
| 47105-46 | 46     | 6       |
| 47105-50 | 50     | 6       |

**With reinforced tip, seam and hanger. Cotton with multi-layer water-proof plastic coating.**



**Icing bag**

Sacchetto per decorare  
Spritzbeutel  
Sac à dresser  
Mangas para decorar

| art.     | h. cm. | U. Pack |
|----------|--------|---------|
| 47105-55 | 55     | 6       |
| 47105-60 | 60     | 6       |
| 47105-65 | 65     | 6       |
| 47105-70 | 70     | 6       |
| 47105-75 | 75     | 6       |

**Con punta rinforzata, orlo e gancio. Cotone con rivestimento a strati in plastica impermeabile.**



**Icing bag**

Sacchetto per decorare  
Spritzbeutel  
Sac à dresser  
Mangas para decorar

| art.     | h. cm. | U. Pack |
|----------|--------|---------|
| 47119-30 | 30     | 6       |
| 47119-35 | 35     | 6       |
| 47119-40 | 40     | 6       |
| 47119-45 | 45     | 6       |
| 47119-50 | 50     | 6       |
| 47119-60 | 60     | 6       |

**With reinforced tip, seam and hanger. Polyurethan with nylon coating. High frequency electric seaming.** – Con punta rinforzata, orlo e gancio. Poliuretano con rivestimento in nylon. Saldatura ad alta frequenza.



PE

**Double pastry bag**

Sacchetto per decorare doppio  
Doppeldressierbeutel  
Sac à dresser, double  
Mangas para decorar, doble

| art.     | my | cm.       | pcs/pz |
|----------|----|-----------|--------|
| 47104-45 | 70 | 45,5x30,5 | 75     |

**Disposable. For 2 ingredients. Closed tip, can be used without tube.**

Monouso. Per 2 ingredienti. Punta chiusa, può essere utilizzato senza bocchette.



**Icing bag, polyurethane**

Sacchetto per decorare, poliuretano  
Spritzbeutel, Polyurethan  
Sac à dresser, polyuréthane  
Mangas para decorar, poliuretano

| art.     | h. cm. |
|----------|--------|
| 47112-34 | 34     |
| 47112-45 | 45     |
| 47112-50 | 50     |



PE

**Disposable icing bag**

Sacchetto per decorare, monouso  
Einwegspritzbeutel  
Sac à dresser jetable  
Mangas desechables

| art.     | my | h. cm. | pcs/pz |
|----------|----|--------|--------|
| 47118-30 | 80 | 30     | 100    |
| 47118-40 | 80 | 40     | 100    |
| 47118-55 | 80 | 55     | 100    |
| 47118-65 | 80 | 65     | 100    |



PE

**Disposable icing bag**

Sacchetto per decorare, monouso  
Einwegspritzbeutel  
Sac à dresser jetable  
Mangas desechables

| art.     | my | h. cm. | pcs/pz |
|----------|----|--------|--------|
| 47111-30 | 80 | 30     | 100    |
| 47111-40 | 80 | 40     | 100    |
| 47111-46 | 80 | 55     | 100    |
| 47111-55 | 80 | 65     | 100    |



PE

**Disposable icing bag**

Sacchetto per decorare, monouso  
Einwegspritzbeutel  
Sac à dresser jetable  
Mangas desechables

| art.     | my  | h. cm. | pcs/pz |
|----------|-----|--------|--------|
| 47114-40 | 100 | 40     | 80     |
| 47114-55 | 100 | 55     | 80     |



BPA FREE

PP

**Bag clip**

Clip chiudi sacco  
Verschluss-Clip  
Clip ferme sachet  
Pinza cierra bolsas

| art.     | cm. | pcs/pz |
|----------|-----|--------|
| 42908-24 | 21  | 1      |

**Freezer, dishwasher and microwave safe. Safe to use with food.** – Idonei ad uso in freezer, lavastoviglie e microonde. Per alimenti.



SS

**Cookie press and icing set 20 pcs**

Siringa per pasticceria, set 20 pezzi  
Gebäckspritze-Satz, 20 Stk.  
Seringue à biscuits, jeu 20 pcs  
Juego pistola repostería, juego 20 pcs.

| art.     | ml. |
|----------|-----|
| 47010-20 | 250 |

**For a correct use of the syringe we suggest shortbread dough.** – Per un utilizzo ottimale della siringa suggeriamo la frolla montata.



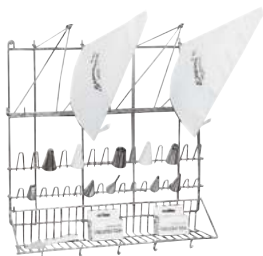

SS

**Icing bags & nozzles wall rack**  
Espositore sacchetti/bocchette  
Spritzbeutel-/ u. Tüllenaufhänger  
Séchoir à poche et douilles  
Secador mangas y boquillas

art. dim. cm.  
47113-03 50x42x50



SS

**Wall rack for icing bags**  
Espositore per sacchetti  
Spritzbeutelaufräger  
Séchoir à poche  
Secador cuelga-mangas

art. dim. cm.  
47107-00 50x42x26

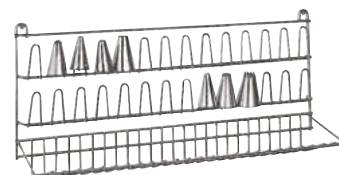

SS

**Wall rack for nozzles**  
Espositore per bocchette  
Tüllenaufhänger  
Séchoir à douilles  
Secador boquillas

art. dim. cm.  
47108-00 50x13x24



PP

**Icing bag holder**  
Vaso porta sacchetto  
Spritzbeutel-Absetzständer  
Support à poches  
Soporte para mangas

art. Ø cm. h. cm.  
47110-23 19,5 23



**Cake plate, swivel base, aluminum**  
Girello, alluminio  
Tortendrehplatte, aluminium  
Guéridon plaque tournante, alu  
Pedestal giratorio para tartas, aluminio

art. Ø cm. h. cm.  
47101-30 30 10



**Cake plate, swivel base, aluminum**  
Girello, alluminio  
Tortendrehplatte, aluminium  
Guéridon plaque tournante, alu  
Pedestal giratorio para tartas, aluminio

art. dim. cm.  
47101-40 30x40x10



MF

**Cake-plate, swivel base**  
Girello per decorazione torte  
Tortendrehplatte  
Guéridon plaque tournante  
Pedestal giratorio para tartas

art. Ø cm. h. cm.  
47103-32 32 10



PE

**Protection cover**  
Campana  
Abdeckhauben  
Cloche  
Tapa

art. Ø cm. h. cm.  
47103-30 30 12



SS

**Cake peel**  
Pala per torte  
Tortenschaukel  
Pelle à tarte  
Pala para tartas

art. Ø cm. dim. cm.  
47094-30 30 27x26



**Doilies**  
Pizzi sottotorta  
Tortenspitzen, Rosendekor  
Dentelles décor rose  
Blondas

art. dim. cm. pcs/pz  
47687-24 18-25 250



**Doilies**  
Pizzi sottotorta  
Tortenspitzen, Rosendekor  
Dentelles décor rose  
Blondas

art. dim. cm. pcs/pz  
47686-10 6-10 250  
47686-12 6,5-12 250  
47686-14 8-14 250  
47686-17 9,5-16,5 250  
47686-22 12,5-22 100  
47686-24 15-24 100



**Doilies**  
Pizzi sottotorta  
Tortenspitzen, Rosendekor  
Dentelles décor rose  
Blondas

art. dim. cm. pcs/pz  
47686-26 16-27 100  
47686-30 19-30 100  
47686-33 20-32 100  
47686-36 32-36 100  
47686-42 25-42 100



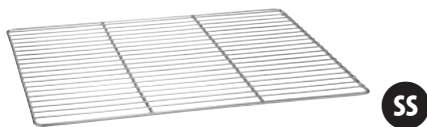

**Draining rack**

Griglia di colaggio  
Überziehgitter  
Grille à glacer  
Rejilla

art. dim. cm.  
44430-60 60x40

**Frame ø mm 5, 2 cross-bars, 29 wires ø 2 mm.**  
Quadro ø mm 5, 2 traverse, 29 fili ø 2 mm.

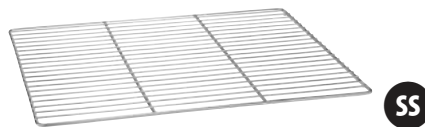

**Draining rack**

Griglia di colaggio  
Überziehgitter  
Grille à glacer  
Rejilla

art. dim. cm.  
44430-61 60x40

**Frame ø mm 6, 2 cross-bars, 24 wires ø 3 mm.**  
Quadro ø mm 6, 2traverse, 24 fili ø 3 mm.



**Draining rack**

Griglia di colaggio  
Überziehgitter  
Grille à glacer  
Rejilla

art. dim. cm.  
44431-46 46x30,5x2,5  
44431-60 60x40x2,5

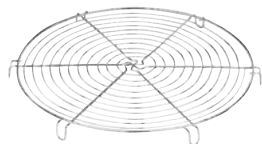

**Cake cooling tray, chromed**

Griglia di raffreddamento, cromata  
Tortengitter, verchromt  
Grille ronde à tourte, chromé  
Rejilla para tortas, cromada

art. Ø cm.  
47098-18 18,5  
47098-22 22,0  
47098-26 26,0  
47098-30 30,0



**Baking tray, aluminum**

Teglia, alluminio  
Backblech, Aluminium  
Plaque à cuisson, aluminium  
Placa pastelería, aluminio

art. GN dim. cm.  
41744-32 1/1 32,5x53x1  
41744-53 2/1 53x65x1  
41744-60 - 60x40x1



**Baking tray perforated, aluminum**

Teglia forata, alluminio  
Backblech, Aluminium, gelocht  
Plaque perforée, aluminium  
Placa pastelería perforada, aluminio

art. GN dim. cm.  
41756-30\* - 30x40x1  
41756-32 1/1 32,5x53x1  
41756-53 2/1 53x65x1  
41756-60 - 60x40x1

\* **Open edges.** – Angoli aperti.



**Baking tray, alusteel**

Teglia rettangolare, alluminata  
Backblech mit Aluminiumüberzug  
Plaque, tôle aluminitée  
Placa pastelería, aluminizada

art. dim. cm.  
41746-60 60x40x2



**Baking tray, alusteel**

Teglia rettangolare, alluminata  
Backblech mit Aluminiumüberzug  
Plaque, tôle aluminitée  
Placa pastelería, aluminizada

art. dim. cm.  
41751-30 30x23x3  
41751-35 35x28x3  
41751-40 40x30x3  
41751-50 50x35x3  
41751-60 60x40x3  
41751-65 65x45x3



**Baking tray, non stick coated**  
Teglia rettangolare, antiaderente  
Backblech mit Antihafbeschichtung  
Plaque revêtement anti-adhésif  
Placa pastelería anti-adherente

| art.     | dim. cm. |
|----------|----------|
| 41747-60 | 60x40x1  |



**Baking tray, non stick coated**  
Teglia antiaderente  
Blech mit Antihafbeschichtung  
Plaque avec revêtement anti-adhésif  
Placa antiadherente

| art.     | GN  | dim. cm.  |
|----------|-----|-----------|
| 41743-32 | 1/1 | 32,5x53x1 |
| 41743-53 | 2/1 | 53x65x1   |
| 41743-60 | -   | 60x40x1   |



**Baking tray perforated, non stick coated**  
Teglia forata, antiaderente  
Blech, gelocht mit Antihafbeschichtung  
Plaque perforée, revêtement anti-adhésif  
Placa perforada, antiadherente

| art.      | GN  | dim. cm.  |
|-----------|-----|-----------|
| 41753-30* | -   | 30x40x1   |
| 41753-32  | 1/1 | 32,5x53x1 |
| 41753-53  | 2/1 | 53x65x1   |
| 41753-60  | -   | 60x40x1   |

\* Open edges. – Angoli aperti.



DEMARLE

**Baking tray, aluminum, silicone coated**  
Teglia, alluminio siliconato  
Alu-Backblech, Silikonbeschichtet  
Plaque alu, revêtement silicone  
Placa aluminio siliconada

| art.     | GN  | dim. cm. |
|----------|-----|----------|
| 41743D32 | 1/1 | 53x32,5  |
| 41743D53 | -   | 53x65    |
| 41743D60 | -   | 40x60    |



DEMARLE

**Baking tray, perforated aluminum, silicone coated**  
Teglia, alluminio siliconato, forato  
Alu-Backblech, gelocht, Silikonbeschichtet  
Plaque alu perforée, revêtement silicone  
Placa aluminio perforada siliconada

| art.     | GN  | dim. cm. |
|----------|-----|----------|
| 41753D30 | -   | 30x40    |
| 41753D32 | 1/1 | 53x32,5  |
| 41753D53 | -   | 53x65    |
| 41753D60 | -   | 40x60    |



**Bread mold, blue steel**  
Bacinella carré, ferro blu  
Brotform, Blaublech  
Pain de mie, tôle bleuie  
Molde, hierro

| art.     | dim. cm. |
|----------|----------|
| 41748-20 | 20x10x10 |
| 41748-30 | 30x10x10 |
| 41748-35 | 35x10x10 |
| 41748-40 | 40x10x10 |
| 41748-50 | 50x10x10 |



**Bread mold, alusteel**  
Bacinella carré, alluminata  
Brotform mit Aluminiumüberzug  
Pain de mie, tôle aluminitée  
Molde, acero aluminizado

| art.     | dim. cm. |
|----------|----------|
| 41750-20 | 20x10x10 |
| 41750-30 | 30x10x10 |
| 41750-40 | 40x10x10 |
| 41750-41 | 40x15x15 |
| 41750-50 | 50x10x10 |



SS

**Confectionery funnel**  
Imbuto colatore  
Likör- u. Fondanttrichter  
Entonnoir à fondant  
Embudo colador

| art.     | Ø cm. | h. cm. | lt. |
|----------|-------|--------|-----|
| 47800-22 | 22    | 21     | 2   |

Supplied with 3 nozzles ø 2, 4, 6 mm.  
Con 3 bocchette ø 2, 4, 6 mm.



PC

**Confectionery funnel**  
Imbuto colatore  
Likör- u. Fondanttrichter  
Entonnoir à fondant  
Embudo colador

| art.     | Ø cm. | h. cm. | lt. |
|----------|-------|--------|-----|
| 47801-20 | 14    | 20     | 0,9 |

Supplied with 3 nozzles ø 4, 6, 7,5 mm.  
Con 3 bocchette ø 4, 6, 7,5 mm.





SS

**Cream dispenser**

Dosa creme

Dosierer

Doseur à crème

Dosificador

| art.     | dim. cm. |
|----------|----------|
| 47612-01 | 20x16x23 |



**Cream injector, cast aluminum**

Dosatrice per creme, alluminio pressofuso

Gebäkfüllmaschine

Entonnoir à crème

Dosificador de porciones

| art.     | dim. cm. | lt. |
|----------|----------|-----|
| 47694-03 | 44x25    | 3   |

**Funnel, cylinder, piston, injector, lever and thrust rib in s/s. Piston: ø 24 mm. Doses: 1-12 gr.**

Imbuto, cilindro, pistone, iniettore, leva e nasello di spinta in acciaio inox. Pistone: ø 24 mm. Dosi: 1-12 gr.



**Caramelising rod**

Caramellizzatore

Carameliser-Eisen

Fer à caraméliser

Quemador

| art.     | Ø cm. |
|----------|-------|
| 47846-10 | 10,5  |



**Electric caramelising rod**

Caramellizzatore elettrico

Carameliser-Eisen, elektrisch

Fer à caraméliser électrique

Quemador eléctrico

| art.     | Ø cm. | kW   |
|----------|-------|------|
| 47847-10 | 10    | 0,65 |
| 47847-12 | 12    | 1,00 |



**Electric caramelising rod**

Caramellizzatore elettrico

Carameliser-Eisen, elektrisch

Fer à caraméliser électrique

Quemador eléctrico

| art.     | l. cm. | kW  |
|----------|--------|-----|
| 47847-23 | 23     | 1,5 |



**Electric spray gun**

Pistola elettrica

Sprühpistole, elektrisch

Pistolet électrique

Pistola eléctrica

| art.     | ml. | W  |
|----------|-----|----|
| 47848-07 | 700 | 60 |

**Bar 0-160, rpm 250 - For butter, oil, fat, wax, jelly, jam, chocolate, releasing agents and emulsions. Usable for hot liquids max. 65 °C. Nozzle 0,6 mm.** – Per burro, oli, cera, gelatina, marmellata, cioccolata, antiagglomeranti ed emulsionanti. Per liquidi caldi max. 65°C. Bocchetta 0,6 mm.



**Airbrush compressor**

Compressore per penna aerografa

Airbrush Kompressor

Compresseur

Compressor

| art.     | dim. cm. | bar | kW  |
|----------|----------|-----|-----|
| 47844-06 | 16x30x23 | 4   | 0,2 |

**Power 1/5 HP. Air output per min./litres: 23-25. Voltage: 220-240V/50HZ. Max. pressure 6,5 bar/95PSI.** – Potenza 1/5 HP. Volume aria min. 23-25L. Voltaggio 220-240V/50HZ. Pressione Massima 6,5 bar/95PSI.



**Airbrush, double action**

Penna aerografa, doppia azione

Airbrush-Pistole, Doppelaktion

Aérographe, dual action

Equipo aerógrafo, doble acción

| art.     | Ø mm. | cap. |
|----------|-------|------|
| 47844-02 | 0,3   | 7 cc |



**Airbrush stand**

Supporto penna aerografa

Airbrush-Pistole Gestell

Support aérographe

Soporte aerógrafo

|      |          |
|------|----------|
| art. | 47844-01 |
|------|----------|



SS

**Sugar lamp**

Lampada per zucchero  
Zuckerlampe  
Lampe à sucre  
Lámpara para azúcar

art. dim. cm.  
47840-11 61x41x50

**Infrared lamp, 3 selection powers 500-1000-1500W. Cable included.** – Lampada infrarossi con 3 potenze selezionabili, 500-1000-1500W. Incl. cavo di alimentazione.



ABS

**Tempering unit**

Temperatrice  
Temperiergerät  
Tempereuse  
Templadora

art. Ø cm. h. cm. lt.  
47698-01 20,5 21,2 1,7

**Ideal for chocolate coatings of ice creams on sticks. Removable anodized aluminum tank.** Ideale per coperture in cioccolato di gelati su stecco. Vasca estraibile in alluminio anodizzato.



ABS

**Tempering unit**

Temperatrice  
Temperiergerät  
Tempereuse  
Templadora

art. Ø cm. h. cm. lt.  
47698-02 26 16 1,8

**Mini dry melter, allows to process tiny chocolate quantities. Practical removable tank.** Mini scioglitore a secco, adatto per piccole produzioni. Pratica vasca estraibile.



SS

ABS

**Tempering unit**

Temperatrice  
Temperiergerät  
Tempereuse  
Templadora

art. dim. cm. lt.  
47698-03 40x24x13,5 3,6  
47698-06 40x33x13,5 6,0

**Analog tempering units. Different wirings upon request.** – Temperatrici analogiche. Su richiesta cablaggio: GB/USA/GIAPPONE/AUSTRALIA/CINA.



ABS

SS

**Tempering unit, digital**

Temperatrice digitale  
Temperiergerät, digital  
Tempereuse digitale  
Templadora digital

art. dim. cm. lt.  
47698-07 40x33x13,5 6,0

**With thermal probe. Tempering manually adjustable or following the 3 programs: white, milk and dark chocolate.**

Con sonda termica. Temperaggio regolabile manualmente o seguendo i 3 programmi per cioccolato bianco, al latte e fondente.



**Chef's torch**

Cannello professionale  
Profi-Wärmepistole  
Chalumeau de cuisine  
Soplete cocina

art. dim. cm. ml.  
47841-03 8x7x16 200



**Chef's torch**

Cannello professionale  
Profi-Wärmepistole  
Chalumeau de cuisine  
Soplete cocina

art. dim. cm. ml.  
47841-04 12x7x18 280



**Sugar bulb**

Pompetta con terminale in rame  
Blaszuckerspritze  
Poire à sucre soufflé  
Pera para azúcar soplado

art.  
47838-00







**Sugar/jam thermometer**

Termometro per zucchero/marmellata  
Zucker- und Marmeladenthermometer  
Thermomètre à sucre et confiture  
Termómetro azúcar y mermelada

| art.     | scala | °C        |
|----------|-------|-----------|
| 47843-05 | 2°C   | +40+200°C |

**Brass. – Ottone. Dim. 4,7x20 cm.**



**SS**

**Sugar thermometer**

Termometro per zucchero  
Zuckerthermometer  
Thermomètre à sucre  
Termometro para azúcar

| art.     | scala | °C      |
|----------|-------|---------|
| 47843-00 | 1°C   | +80+200 |



**SS**

**Sugar thermometer holder**

Reggi caramellometro  
Zuckerthermometer-Träger  
Support pour thermomètre à sucre  
Soporte para termometro azúcar

| art.     | h. cm. |
|----------|--------|
| 47842-00 | 32     |



**Syrup density meter test tube**

Provetta alimentare graduata, plastica  
Sirup-Hydrometer-Becher  
Epruvette pèse-sirop  
Probeta aerómetro

| art.     | Ø cm. | h. cm. | ml. |
|----------|-------|--------|-----|
| 49703-01 | 3     | 25     | 100 |

**Can be sterilized up to 120°C.**  
Sterilizzabile fino a 120°C.



**Syrup density meter**

Pesa sciroppo (densimetro)  
Sirup-Hydrometer  
Pèse-sirop  
Aerómetro

| art.     | l. cm. |
|----------|--------|
| 49703-00 | 12,5   |

**Temp.: 20°C - gr./ml.°Bé: 1.100/1.400/15-40 - Div.: 0,010 g/ml/2°Bé**



**PA+**  
plus

**Angular spatula**

Spatola angolare  
Winkelpalette  
Spatule angulaire  
Espátula angular

| art.     | l. cm. |
|----------|--------|
| 12909-12 | 12     |
| 12909-23 | 23     |



**ABS**

**Smoother**

Stendipasta  
Teig-Glätter  
Lisse-pâte  
Espátula para alisar

| art.     | dim. cm. |
|----------|----------|
| 47627-01 | 16x8     |



**Biscuit spatula**

Spatola per biscuit  
Biscuit-Spachtel  
Spatule à biscuit  
Espátula para biscuit

| art.     | l. cm. |
|----------|--------|
| 47626-55 | 55,5   |



**Ruler**

Riga  
Lineal  
Règle  
Regla

| art.     | l. cm. |
|----------|--------|
| 47033-50 | 60     |

**5 divisions cm 12 and 7 divisions cm 8.**  
5 divisioni 12 cm e 7 da 8 cm.



**Cake slicer**

Lira per pan di Spagna  
Tortendrahtschneider  
Lyre à genoise  
Cortador de pasteles

| art.     | Ø cm. | h. cm. |
|----------|-------|--------|
| 47031-44 | 30    | 20>60  |



**Cake slicer, 3 cutting wires**

Lira per pan di Spagna, 3 fili  
Tortendrahtschneider, 3 Drähte  
Lyre à genoise, 3 lames  
Cortador de pasteles 3 alambres

| art.     | Ø cm. | h. cm. |
|----------|-------|--------|
| 47031-46 | 46    | 10>90  |



PE

**Ganache frame set**

Set telaio per ganache  
Ganache Rahmenset  
Ensemble cadres à ganache  
Conjunto de marcos para ganache

| art.     | dim. cm. |
|----------|----------|
| 47693-00 | 39x45x13 |

**Base, plastic spatula, 2 frames H 5 mm, 2 frames H 3 mm. Internal size 24x24 cm.**

Base, spatola plastica, 2 telai H 5 mm, 2 telai H 3 mm. Misura interna 24x24 cm.

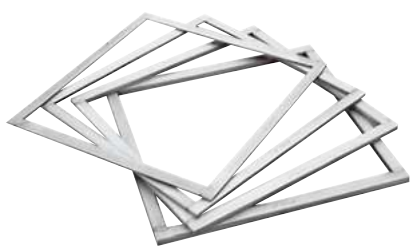

SS

**Single frame**

Telaio singolo  
Rahmen  
Cadre  
Marco

| art.     | cm. ext. | cm. int. | h. mm. |
|----------|----------|----------|--------|
| 47693-03 | 40x40    | 36x36    | 3      |
| 47693-05 | 40x40    | 36x36    | 5      |
| 47693-10 | 40x40    | 36x36    | 10     |
| 47693-15 | 40x40    | 36x36    | 15     |



PE

ABS

SS

**Mini guitar**

Chitarra mini  
Pralinenschneider Mini  
Mini-guitare  
Mini guitarra

| art.     | dim. cm.     |
|----------|--------------|
| 47692-03 | 44,5x33,5x14 |

**Cutting frame 22 mm., s/s plate, plastic spatula, 3 spare wires, 2 spanners. Do not use for frozen pies, chocolate bars or generally hard paste. Cutting place 25x28 cm.** – Telaio di taglio 22 mm., piatto inox, spatola plastica, 3 fili di ricambio, 2 chiavi. Non usare per torte congelate, tavolette di cioccolata, impasti duri in genere. Piano di taglio 25x28 cm.



**Guitar**

Chitarra  
Pralinenschneider  
Guitare simple  
Guitarra

| art.     | dim. cm. |
|----------|----------|
| 47692-01 | 39x45x13 |



**Double guitar**

Chitarra doppia  
Pralinenschneider, doppelt  
Guitare double  
Guitarra doble corte

| art.     | dim. cm. |
|----------|----------|
| 47692-02 | 39x45x13 |

**PST base, 3 s/s cutting frames of 22,5 - 30 - 45 mm. Including s/s plate, plastic spatula, 3 spare wires, 2 spanners. Cutting place 36x41 cm.** – Base PST, 4 telai inox da 22,5 - 30 e 45 mm. Inclusi piatto inospatola plastica, 3 fili di ricambio, 2 chiavi. Piano di taglio 36x41 cm.

**PST base, 4 s/s cutting frames of 22,5 - 30 - 45 mm. and fixed side cutting frame 30 mm. Including s/s plate, plastic spatula, 3 spare wires, 2 spanners. Cutting place 38x42 cm.** – Base PST, 4 telai inox da 22,5 - 30 - 45 e laterale fisso da 30 mm. Inclusi piatto inox, spatola plastica, 3 fili di ricambio, 2 chiavi. Piano di taglio 38x42 cm.



SS

**Expanding pastry cutter**

Tagliapasta estensibile

Teigschneider

Rouleau extensible

Cortapastas extensible

| art.     | Ø cm. | l. cm. |
|----------|-------|--------|
| 47820-05 | 5,5   | 24     |
| 47820-07 | 5,5   | 24     |



SS

**Expanding pastry cutter**

Tagliapasta estensibile

Teigschneider

Rouleau extensible

Cortapastas extensible

| art.     | Ø cm. | l. cm. |
|----------|-------|--------|
| 47821-05 | 5,5   | 24     |
| 47821-07 | 5,5   | 24     |



SS

**Expanding pastry cutter**

Tagliapasta estensibile

Teigschneider

Rouleau extensible

Cortapastas extensible

| art.     | Ø cm. | l. cm. |
|----------|-------|--------|
| 47822-05 | 5,5   | 28     |
| 47822-07 | 5,5   | 28     |



SS

**Pastry wheel, plain**

Rotella taglia pasta liscia

Teigrädchen, glatt

Roulette à pâte lisse

Ruleta cortapasta

| art.     | Ø cm. | l. cm. |
|----------|-------|--------|
| 18325-01 | 5,5   | 18     |



SS

**Pastry wheel, fluted**

Rotella taglia pasta ondulata

Teigrädchen, gewellt

Roulette à pâte cannelée

Ruleta cortapasta acanalada

| art.     | Ø cm. | l. cm. |
|----------|-------|--------|
| 18325-02 | 5,5   | 18     |



SS

**Double pastry wheel**

Rotella taglia pasta lama doppia

Teigrädchen, glatt u. gewellt

Roulette à pâte double

Ruleta cortapasta doble

| art.     | Ø cm. | l. cm. |
|----------|-------|--------|
| 18325-03 | 5,5   | 18     |



**Cutting roller, POM**

Rullo tagliapasta, POM

Rollmesser, POM

Rouleau à lamelles, POM

Rodillo, POM

| art.     | cm. |
|----------|-----|
| 47026-06 | 6   |



**Spiked roller, POM**

Rullo buca sfoglia, POM

Stipprolle, POM

Pique-pâte, POM

Rodillo, POM

| art.     | cm.  |
|----------|------|
| 47024-06 | 6,0  |
| 47024-10 | 11,5 |



**Cutting roller, POM**

Rullo per losanghe, POM

Rollmesser, POM

Rouleau à losanges, POM

Rodillo a rombos, POM

| art.     | cm.  |
|----------|------|
| 47025-06 | 6,0  |
| 47025-10 | 11,5 |



SS

**Spiked roller**

Rullo buca sfoglia

Stipprolle

Pique-pâte

Rodillo

| art.     | cm. |
|----------|-----|
| 47028-12 | 12  |



SS

**Cutting roller**

Rullo per losanghe

Dreieckschneidewalze

Rouleau à losanges

Rodillo a rombos

| art.     | cm. |
|----------|-----|
| 47029-12 | 12  |



PP

SS

**Croissant cutter**

Taglia croissants

Dreieckschneidewalze

Coupe-croissants

Cortador para croissants

| art.     | dim. cm. |
|----------|----------|
| 47027-11 | 18x20    |
| 47027-12 | 18x14    |
| 47027-13 | 11x15    |
| 47027-14 | 9,7x21   |
| 47027-15 | 18x20 2x |
| 47027-16 | 18x20 3x |

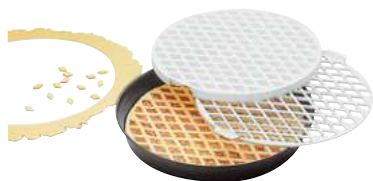

PS

**Stencil for grating pastry**

Stampo decora crostate  
Gitterstempel  
Empreinte pour grille de pâte  
Molde tortas

| art.     | Ø cm. |
|----------|-------|
| 47030-30 | 30    |



PP

**Cake marker**

Segnaporzioni  
Tortenteiler  
Diviseur à tarte  
Marcador de tartas

| art.     | Ø cm. | por. |
|----------|-------|------|
| 47032-10 | 26,5  | 10   |
| 47032-20 | 26,5  | 20   |



PP

**Cake marker, double-sided**

Segnaporzioni, doppio  
Tortenteiler, doppelseitig  
Diviseur à tarte, double  
Marcador de tartas, doble

| art.     | Ø cm. | por.  |
|----------|-------|-------|
| 47033-08 | 18    | 8-12  |
| 47033-12 | 26,5  | 12-18 |
| 47033-14 | 26,5  | 14-18 |



**Rolling pin, non-stick coated**

Rullo antiaderente  
Rollwalze mit Antihafbeschichtung  
Rouleau avec revêtement anti-adhésif  
Rodillo amasador anti-adherente

| art.     | Ø cm. | l. cm. |
|----------|-------|--------|
| 47035-40 | 5,5   | 20     |
| 47035-48 | 6,5   | 25     |



W

**Rolling pin**

Rullo  
Rollwalze  
Rouleau  
Rodillo amasador

| art.     | Ø cm. | l. cm. |
|----------|-------|--------|
| 47036-30 | 9     | 30     |
| 47036-35 | 9     | 35     |
| 47036-40 | 9     | 40     |
| 47036-45 | 9     | 45     |
| 47036-50 | 9     | 50     |
| 47036-60 | 9     | 60     |



W

**Rolling pin**

Rullo  
Rollwalze  
Rouleau  
Rodillo amasador

| art.     | Ø cm. | l. cm. |
|----------|-------|--------|
| 47038-50 | 9     | 50     |
| 47038-60 | 7     | 60     |



PE

**Rolling pin**

Rullo  
Rollwalze  
Rouleau  
Rodillo amasador

| art.     | Ø cm. | l. cm. |
|----------|-------|--------|
| 47037-30 | 8,0   | 30     |
| 47037-40 | 7,5   | 40     |



PE

**Rolling pin**

Rullo  
Rollwalze  
Rouleau  
Rodillo amasador

| art.     | Ø cm. | l. cm. |
|----------|-------|--------|
| 47034-23 | 2,5   | 23     |
| 47034-51 | 5,0   | 50     |



W

**Rolling pin**

Rullo  
Rollwalze  
Rouleau  
Rodillo amasador

| art.     | Ø cm. | l. cm. |
|----------|-------|--------|
| 47034-52 | 5     | 50     |



SS

**Rolling pin**

Rullo  
Rollwalze  
Rouleau  
Rodillo amasador

| art.     | Ø cm. | l. cm. |
|----------|-------|--------|
| 47034-50 | 5     | 50     |



PE

**Rolling dough cutter**

Rullo tagliapasta  
Rollholzer  
Rouleau coupe-bandes  
Rodillo cortador

| art.     | l. cm. | cut mm. |
|----------|--------|---------|
| 47039-05 | 19     | 5       |
| 47039-10 | 19     | 10      |





PE

**Rolling dough cutter**

Rullo tagliapasta  
Rollholzer  
Rouleau coupe-bandes  
Rodillo cortador

| art.     | l. cm. | cut mm. |
|----------|--------|---------|
| 47039-15 | 19     | 15      |



NEW

**Pastry brush non-stick coated bristles**

Pennello setole antiaderenti  
Pinself, antihafbeschichtete Borsten  
Pinceau poils anti-adhérentes  
Pincel cerdas antiaderentes

| art.     | cm. | U. Pack |
|----------|-----|---------|
| 47640-25 | 2,5 | 1       |
| 47640-35 | 3,5 | 1       |
| 47640-50 | 5,0 | 1       |
| 47640-59 | 6,0 | 1       |

**Nylon bristles. Heat resistant up to +150°C.**  
Setole nylon. Resistente al calore fino a +150°C.



**Pastry brush**

Pennello per alimenti  
Kuchenpinsel  
Pinceaux à pâtissier  
Pincel de cocina

| art.     | cm. | U. Pack |
|----------|-----|---------|
| 47642-30 | 3,0 | 6       |
| 47642-40 | 4,0 | 6       |
| 47642-50 | 5,0 | 6       |
| 47642-60 | 6,0 | 6       |
| 47642-70 | 7,5 | 6       |

**Plastic handle, stainless steel ferrule.**  
Manico plastica, ghiera inox.



**Pastry brush**

Pennello per alimenti  
Kuchenpinsel  
Pinceaux à pâtissier  
Pincel de cocina

| art.     | Ø cm. | U. Pack |
|----------|-------|---------|
| 47644-15 | 1,5   | 6       |

**Plastic handle and ferrule.**  
Manico e ghiera plastica.



PA

**Pastry brush**

Pennello per alimenti  
Kuchenpinsel  
Pinceaux à pâtissier  
Pincel de cocina

| art.     | cm. | U. Pack |
|----------|-----|---------|
| 47645-40 | 4   | 6       |
| 47645-60 | 6   | 6       |
| 47645-75 | 7,5 | 6       |

**Natural bristles. – Setole naturali.**



PA

**Pastry brush**

Pennello per alimenti  
Kuchenpinsel  
Pinceaux à pâtissier  
Pincel de cocina

| art.     | cm. | U. Pack |
|----------|-----|---------|
| 47646-40 | 4   | 6       |
| 47646-60 | 6   | 6       |
| 47646-75 | 7,5 | 6       |

**Polyester bristles. – Setole in poliestere.**



PP

**Set 10 dough scrapers**

Set 10 raschietti  
Teigschaber, 10 Stk.  
Set 10 raclettes  
Conjunto 10 rasquetas

| art.     | dim. mm. |
|----------|----------|
| 47621-01 | 216x128  |



PP

**Set 10 dough scrapers**

Set 10 raschietti  
Teigschaber, 10 Stk.  
Set 10 raclettes  
Conjunto 10 rasquetas

| art.     | dim. mm. |
|----------|----------|
| 47621-02 | 120x86   |



PP

**Set 10 dough scrapers**

Set 10 raschietti  
Teigschaber, 10 Stk.  
Set 10 raclettes  
Conjunto 10 rasquetas

| art.     | dim. mm. |
|----------|----------|
| 47621-03 | 120x88   |



PP

**Set 10 dough scrapers**

Set 10 raschietti  
Teigschaber, 10 Stk.  
Set 10 raclettes  
Conjunto 10 rasquetas

| art.     | dim. mm. |
|----------|----------|
| 47621-04 | 121x81   |



PP

**Set 10 dough scrapers**

Set 10 raschietti  
Teigschaber, 10 Stk.  
Set 10 raclettes  
Conjunto 10 rasquetas

| art.     | dim. mm. |
|----------|----------|
| 47621-05 | 148x99   |



PP

**Set 10 decorating combs**

Set 10 pettini decoratori  
Dekorationskamm, 10 Stk.  
Set 10 peignes à decor  
Conjunto 10 peines decoradores

| art.     | dim. mm. |
|----------|----------|
| 47621-06 | 145x99   |



PP

**Set 10 decorating combs**

Set 10 pettini decoratori  
Dekorationskamm, 10 Stk  
Set 10 peignes à decor  
Conjunto 10 peines decoradores

art. dim. mm.  
47621-07 110x80



PP

**Set 10 decorating combs**

Set 10 pettini decoratori  
Dekorationskamm, 10 Stk  
Set 10 peignes à decor  
Conjunto 10 peines decoradores

art. dim. mm.  
47621-08 216x128



SS

**Set 3 decorating combs**

Set 3 pettini decoratori  
Dekorationskamm, 3 Stk  
Set 3 peignes à decor  
Conjunto 3 peines decoradores

art. dim. mm.  
47625-03 100x100



SS

**Sugar dredger**

Spargi zucchero  
Zuckerstreuer  
Glacière à sucre  
Dosificador para azúcar

art. Ø cm. h. cm.  
47022-12 7 9



PP

**Moisture bottle**

Flacone per bagno  
Sprühflasche  
Bouteille à puncher  
Frasco nebulizador

art. dim. cm. lt.  
47679-10 10x5,6x27,5 1



PP

**Spraying bottle**

Flacone nebulizzatore  
Sprühflasche  
Bouteille à puncher spray  
Frasco nebulizador

art. dim. cm. lt.  
47679-11 7x7x30 1



SS

**Flour sifter**

Setaccio farina  
Einhand-Drücksieb  
Tamiseur farine  
Tamiz para harina

art. Ø cm. gr.  
42607-05 12 500



**Icing sugar sieve**

Setaccio per zucchero a velo  
Sieb für Puderzucker  
Tamis à sucre glace  
Cedazo para azúcar glas

art. Ø cm. h. cm.  
47614-25 23 8



**Sieve for flour**

Setaccio rete farina  
Sieb für Mehl  
Tamis pour farine  
Cedazo para harina

art. Ø cm. h. cm.  
47615-25 23 8



**Flour brush**

Spazzola per farina  
Mehlbürste  
Brosse à pétrin  
Cepillo para harina

art. cm.  
42614-21 30

Horse hair. – Setole di cavallo.



SS

**Display tray**

Vassoio espositore  
Auslegeplatte  
Plat patissier  
Bandeja pastelería

art. dim. cm.  
47075-20 20x16x1  
47075-30 30x21x1  
47075-45 45x34x1



SS

**Display tray**

Vassoio espositore  
Auslegeplatte  
Plat patissier  
Bandeja pastelería

art. dim. cm.  
42533-23 23x16,5x0,5  
42533-26 26x19,5x0,5  
42533-31 31x24x0,5  
42533-36 36x28,5x0,5  
42533-40 40x32,5x0,5



**Display tray, aluminum**

Vassoio espositore, alluminio  
Auslegeplatte, Aluminium  
Plat patissier, alu  
Bandeja pastelería, aluminio

| art.     | dim. cm.    |
|----------|-------------|
| 47070-37 | 37,5x24,5x1 |
| 47070-48 | 48x31x1     |
| 47070-60 | 60x40x1     |



SS

Vassoio espositore  
Auslegeplatte  
Plat patissier  
Bandeja pastelería

| art.     | dim. cm.  |
|----------|-----------|
| 47074-01 | 30x20x1,5 |
| 47074-02 | 40x10x1,5 |
| 47074-03 | 40x20x1,5 |
| 47074-04 | 40x30x1,5 |



SS

Vassoio espositore  
Auslegeplatte  
Plat patissier  
Bandeja pastelería

| art.     | dim. cm.  |
|----------|-----------|
| 47074-05 | 50x10x1,5 |
| 47074-06 | 60x6x1,5  |
| 47074-07 | 60x10x1,5 |
| 47074-08 | 60x20x1,5 |



**Baking paper, siliconized**

Carta da forno siliconata  
Bactrennfolie, silikonisiert  
Feuille de cuisson, siliconée  
Papel de horno siliconado

| art.     | dim. cm. | pcs/pz |
|----------|----------|--------|
| 47682-53 | 53x32,5  | 500    |
| 47682-60 | 60x40    | 500    |

**Artificial parchment, bleached, g/m<sup>2</sup>: 41,0, both sides siliconized, reusable, for all kinds of dough.** – Pergamena artificiale, sbiancata, g/m<sup>2</sup>: 41,0, siliconata fronte/retro, riutilizzabile, idonea per tutti i tipi di pasta.



**Baking paper, PTFE coated**

Carta da forno, rivestimento PTFE  
Bactrennfolie, PTFE-beschichtet  
Feuille de cuisson, revêtement PTFE  
Papel de horno anti-adherente

| art.     | dim. cm. | U. Pack |
|----------|----------|---------|
| 47681-60 | 60x40    | 10      |

**Fiberglass tissue coated on both sides, can be used up to 500 times, tear-proof. Carefully dry after use.**

Tessuto fibra di vetro rivestito fronte/retro, resistente alla trazione, antiaderente, riutilizzabile più di 500 volte. Asciugare dopo l'uso.



**Baking sheet, silicone, microperforated**

Tappeto silicone microforato  
Silikonbackmatte, microperforiert  
Tapis cuisson en silicone, microperforé  
Tapete de cocción silicona, microperforado

| art.     | GN  | dim. cm. |
|----------|-----|----------|
| 47691-53 | 1/1 | 53x32,5  |
| 47691-64 | -   | 60x40    |



**Baking sheet, silicone**

Tappeto silicone  
Silikonbackmatte  
Tapis cuisson en silicone  
Tapete de cocción silicona

| art.     | GN  | dim. cm. |
|----------|-----|----------|
| 47689-53 | 1/1 | 53x32,5  |
| 47689-60 | -   | 60x40    |

SILPAT – SILPAIN – ROUL’PAT



**SILPAT:** Non-stick sheet ideal for backing brioches and buns as well as any kind of sweet bread backed in sheets. **Ideal also for working sugar. SILPAIN:** Non-stick perforated sheet ideal for baking bread and tarts. **ROUL’PAT:** The silicone coating on both sides prevents the sheet from slipping. Perfect to prepare any type of dough and it also enables to easily prepare macaroon.

SILPAT: Antiaderente ideale per la cottura di tutte le viennoiseries e tutti i tipi di pasticceria da panetteria cotti in teglie. Ideale anche per la lavorazione dello zucchero. SILPAIN: Antiaderente areato ideale per la cottura di pani e la cottura in bianco di fondi per crostate. ROUL’PAT: Con il rivestimento in silicone su entrambi i lati, non scivola sul piano di lavoro. Permette di lavorare ogni tipo di pasta, e con grande facilità anche il croccante.



**SILPAT Silicone baking sheet**

Tappeto silicone  
Silikonbackmatte  
Tapis cuisson en silicone  
Tapete de cocción silicona

| art.     | GN  | dim. cm. |
|----------|-----|----------|
| 47680-40 | -   | 40x30    |
| 47680-53 | 1/1 | 53x32,5  |
| 47680-60 | -   | 60x40    |



**SILPAIN Silicone baking sheet**

Tappeto silicone  
Silikonbackmatte  
Tapis de cuisson en silicone  
Tapete de cocción silicona

| art.     | GN  | dim. cm. |
|----------|-----|----------|
| 47685-53 | 1/1 | 53x32,5  |
| 47685-60 | -   | 60x40    |



**ROUL’PAT Silicone baking sheet**

Tappeto silicone  
Silikonbackmatte  
Tapis de cuisson en silicone  
Tapete de cocción silicona

| art.     | dim. cm. |
|----------|----------|
| 47688-60 | 60x40    |



**Baking beans, ceramic**

Noccioli di cottura, ceramica  
Backkerne, Keramik  
Noyaux de cuisson, céramique  
Núcleos de cocción, cerámica

| art.     | Kg. |
|----------|-----|
| 47011-01 | 1   |



**Acetate sheets**

Acetato in fogli  
Acetat Band-Blätter  
Feuilles en acétate  
Hojas de acetato

| art.     | my | dim. cm. | pcs/pz |
|----------|----|----------|--------|
| 47131-30 | 90 | 30x30    | 50     |
| 47131-60 | 90 | 60x40    | 50     |

**Ribbons and sheets to coat molds, to make and unmold single portions and mignons. Non-stick for food use. Suitable for cooling in blast chiller, freezer and fridge, not suitable for cooking. Extra transparent, super resistant.**



**Cake ribbon (PET)**

Nastro per dolci  
Tortenrandband  
Ruban pâtissier  
Cinta para tartas

| art.     | my | h. cm. | mt. |
|----------|----|--------|-----|
| 47130-25 | 90 | 2,5    | 305 |
| 47130-30 | 90 | 3,0    | 305 |
| 47130-35 | 90 | 3,5    | 305 |
| 47130-40 | 90 | 4,0    | 305 |
| 47130-45 | 90 | 4,5    | 305 |
| 47130-50 | 90 | 5,0    | 305 |
| 47130-55 | 90 | 5,5    | 305 |
| 47130-60 | 90 | 6,0    | 305 |

**Nastri e fogli per rivestire stampi, per realizzare e sfornare monoporzioni e mignon. Antiaderenti per uso alimentare. Adatti al raffreddamento in abbattitore, congelatore e frigo, non adatti alla cottura. Extra trasparenti, super resistenti.**





SS

**Tart ring**

Anello per torte  
Tortenring  
Cercle à tarte  
Anillo para tartas

| art.     | Ø cm. | h. cm. |
|----------|-------|--------|
| 47533-07 | 7     | 2      |
| 47533-08 | 8     | 2      |
| 47533-09 | 9     | 2      |
| 47533-10 | 10    | 2      |
| 47533-12 | 12    | 2      |
| 47533-14 | 14    | 2      |
| 47533-16 | 16    | 2      |
| 47533-18 | 18    | 2      |
| 47533-20 | 20    | 2      |
| 47533-22 | 22    | 2      |
| 47533-24 | 24    | 2      |
| 47533-26 | 26    | 2      |
| 47533-28 | 28    | 2      |
| 47533-30 | 30    | 2      |
| 47533-32 | 32    | 2      |



SS

**Tart ring**

Anello per torte  
Tortenring  
Cercle à tarte  
Anillo para tartas

| art.     | Ø cm. | h. cm. |
|----------|-------|--------|
| 47530-14 | 14    | 3,5    |
| 47530-16 | 16    | 3,5    |
| 47530-18 | 18    | 3,5    |
| 47530-20 | 20    | 3,5    |
| 47530-22 | 22    | 3,5    |
| 47530-24 | 24    | 3,5    |
| 47530-26 | 26    | 3,5    |
| 47530-28 | 28    | 3,5    |
| 47530-30 | 30    | 3,5    |



SS

**Mousse ring**

Anello per mousse  
Schaumspeisenring  
Cercle à mousse  
Anillo para mousse

| art.     | Ø cm. | h. cm. |
|----------|-------|--------|
| 47532-06 | 6,0   | 4,0    |
| 47532-07 | 7,5   | 4,0    |
| 47532-08 | 8,0   | 4,5    |
| 47532-12 | 12,0  | 4,5    |
| 47532-14 | 14,0  | 4,5    |
| 47532-16 | 16,0  | 4,5    |
| 47532-18 | 18,0  | 4,5    |
| 47532-20 | 20,0  | 4,5    |
| 47532-22 | 22,0  | 4,5    |
| 47532-24 | 24,0  | 4,5    |
| 47532-26 | 26,0  | 4,5    |



SS

**Ice cream cake ring**

Anello per torte gelato  
Eistortenring  
Cercle à vacherin  
Circulo alto

| art.     | Ø cm. | h. cm. |
|----------|-------|--------|
| 47534-07 | 7     | 9      |
| 47534-08 | 9     | 9      |
| 47534-09 | 7     | 11     |
| 47534-10 | 9     | 11     |



SS

**Ice cream cake ring**

Anello per torte gelato  
Eistortenring  
Cercle à vacherin  
Circulo alto

| art.     | Ø cm. | h. cm. |
|----------|-------|--------|
| 47534-00 | 8     | 6      |
| 47534-01 | 10    | 6      |



SS

**Ice cream cake ring**

Anello per torte gelato  
Eistortenring  
Cercle à vacherin  
Circulo alto

| art.     | Ø cm. | h. cm. |
|----------|-------|--------|
| 47534-06 | 6     | 6      |
| 47534-16 | 16    | 6      |
| 47534-18 | 18    | 6      |
| 47534-20 | 20    | 6      |
| 47534-22 | 22    | 6      |
| 47534-24 | 24    | 6      |
| 47534-26 | 26    | 6      |
| 47534-28 | 28    | 6      |



SS

**Cake setting ring, flexible**

Anello regolabile, flessibile  
Tortenring, verstellbar, flexible  
Cercle à tarte réglable, flexible  
Anillo ajustable, flexible

| art.     | Ø cm.   | h. cm. |
|----------|---------|--------|
| 47529-07 | 16,5>32 | 7      |

MICROPERFORATED CAKE RINGS  
FASCE MICROFORATE

SS



The micro-holes allow to support the edges of the cake avoiding to collapse during cooking. They also allow to expel the moisture from the dough, obtaining a perfect and always crispy cooking.

I microfori permettono di sostenere i bordi della torta evitandone il collasso in cottura. Consentono inoltre di espellere l'umidità, ottenendo una cottura sempre perfetta e croccante.



**Cake ring, microperforated**

Fascia microforata

Tarte-Rahmen perforiert

Cercle microperforé

Anillo tarta microperforado

| art.     | Ø cm. | h. cm. |
|----------|-------|--------|
| 47510-07 | 7     | 3,5    |
| 47510-09 | 9     | 3,5    |
| 47510-11 | 11    | 3,5    |
| 47510-13 | 13    | 3,5    |
| 47510-15 | 15    | 3,5    |
| 47510-17 | 17    | 3,5    |
| 47510-19 | 19    | 3,5    |
| 47510-21 | 21    | 3,5    |
| 47510-23 | 23    | 3,5    |
| 47510-25 | 25    | 3,5    |
| 47510-27 | 27    | 3,5    |
| 47510-29 | 29    | 3,5    |
| 47510-31 | 31    | 3,5    |



**Cake ring, microperforated**

Fascia microforata

Tarte-Rahmen perforiert

Cercle microperforé

Anillo tarta microperforado

| art.     | Ø cm. | h. cm. |
|----------|-------|--------|
| 47511-07 | 7     | 2      |
| 47511-09 | 9     | 2      |
| 47511-11 | 11    | 2      |
| 47511-13 | 13    | 2      |
| 47511-15 | 15    | 2      |
| 47511-17 | 17    | 2      |
| 47511-19 | 19    | 2      |
| 47511-21 | 21    | 2      |
| 47511-23 | 23    | 2      |
| 47511-25 | 25    | 2      |
| 47511-27 | 27    | 2      |
| 47511-29 | 29    | 2      |
| 47511-31 | 31    | 2      |



**Cake ring, microperforated**

Fascia microforata

Tarte-Rahmen perforiert

Cercle microperforé

Anillo tarta microperforado

| art.     | dim. cm. | h. cm. |
|----------|----------|--------|
| 47512-07 | 7x7      | 3,5    |
| 47512-09 | 9x9      | 3,5    |
| 47512-11 | 11x11    | 3,5    |
| 47512-13 | 13x13    | 3,5    |
| 47512-15 | 15x15    | 3,5    |
| 47512-17 | 17x17    | 3,5    |
| 47512-19 | 19x19    | 3,5    |
| 47512-21 | 21x21    | 3,5    |
| 47512-23 | 23x23    | 3,5    |
| 47512-25 | 25x25    | 3,5    |
| 47512-27 | 27x27    | 3,5    |
| 47512-29 | 29x29    | 3,5    |
| 47512-31 | 31x31    | 3,5    |





SS

**Extensible frame**

Telaio regolabile  
Backrahm, verstellbar  
Bande à tarte réglable  
Marco para tarta, ajustable

| art.     | Ø cm.       | h. cm. |
|----------|-------------|--------|
| 47526-05 | 30x30>57x56 | 5      |



SS

**Extensible frame**

Telaio regolabile  
Backrahm, verstellbar  
Bande à tarte réglable  
Marco para tarta, ajustable

| art.     | Ø cm.       | h. cm. |
|----------|-------------|--------|
| 47528-05 | 19x28>34x54 | 5      |



SS

**Extensible heart frame**

Telaio cuore regolabile  
Herz-Backrahm, verstellbar  
Bande à tarte réglable  
Marco para tarta, ajustable

| art.     | Ø cm.     | h. cm. |
|----------|-----------|--------|
| 47542-00 | 14,5>26,5 | 5      |



SS

**Rectangle**

Rettangolo  
Rechteck  
Rectangle  
Rectangular

| art.     | dim. cm.    |
|----------|-------------|
| 47527-55 | 55x35,5x4,5 |



SS

**Rectangle**

Rettangolo  
Rechteck  
Rectangle  
Rectangular

| art.     | dim. cm. |
|----------|----------|
| 47546-18 | 18x36x5  |
| 47546-30 | 30x40x5  |
| 47546-40 | 40x60x5  |



SS

**Square**

Quadrato  
Viereck  
Carré  
Cuadrado

| art.     | dim. cm.  |
|----------|-----------|
| 47548-02 | 10x10x4,5 |
| 47548-03 | 18x18x4,5 |
| 47548-04 | 20x20x4,5 |
| 47548-05 | 22x22x4,5 |



SS

**Rounded square**

Quadrato bombato  
Viereck, konvex  
Carré arrondi  
Cuadrado abombado

| art.     | dim. cm.  |
|----------|-----------|
| 47541-02 | 10x10x4,5 |
| 47541-03 | 18x18x4,5 |
| 47541-04 | 20x20x4,5 |



SS

**Oval**

Ovale  
Oval  
Ovale  
Oval

| art.     | dim. cm.  |
|----------|-----------|
| 47547-22 | 24,5x20x4 |
| 47547-26 | 30x23x4   |
| 47547-30 | 33x26,5x4 |



SS

**Comma**

Virgola  
Komma  
Virgule  
Coma

| art.     | Ø cm. | h. cm. |
|----------|-------|--------|
| 47544-20 | 20    | 4      |
| 47544-25 | 25    | 4      |
| 47544-30 | 30    | 4      |



SS

**Heart**  
Cuore  
Herz  
Coeur  
Corazón

| art.     | Ø cm. | h. cm. |
|----------|-------|--------|
| 47542-18 | 18    | 4      |
| 47542-20 | 20    | 4      |
| 47542-22 | 22    | 4      |
| 47542-24 | 24    | 4      |
| 47542-26 | 26    | 4      |



SS

**Triangle**  
Triangolo  
Dreieck  
Triangle  
Triángulo

| art.     | Ø cm. | h. cm. |
|----------|-------|--------|
| 47540-02 | 12    | 4,5    |
| 47540-03 | 20    | 4,5    |
| 47540-04 | 22    | 4,5    |
| 47540-05 | 24    | 4,5    |



SS

**Triangle**  
Triangolo  
Dreieck  
Triangle  
Triángulo

| art.     | Ø cm. | h. cm. |
|----------|-------|--------|
| 47538-20 | 20    | 4      |
| 47538-23 | 23    | 4      |
| 47538-26 | 26    | 4      |



SS

**Rectangle**  
Rettangolo  
Rechteck  
Rectangle  
Rectangular

| art.     | dim. cm. |
|----------|----------|
| 47546-21 | 25x9x2   |
| 47546-22 | 30x9,1x2 |
| 47546-23 | 35x9,2x2 |



SS

**Rectangle**  
Rettangolo  
Rechteck  
Rectangle  
Rectangular

| art.     | dim. cm. |
|----------|----------|
| 47546-41 | 25x9x4   |
| 47546-42 | 30x9,1x4 |
| 47546-43 | 35x9,2x4 |



SS

**Rectangle**  
Rettangolo  
Rechteck  
Rectangle  
Rectangular

| art.     | dim. cm. |
|----------|----------|
| 47546-51 | 25x9x5   |
| 47546-52 | 30x9,1x5 |
| 47546-53 | 35x9,2x5 |



SS

**Pyramid**  
Piramide  
Pyramide  
Piramide  
Pirámide

| art.     | dim. cm. | h. cm. |
|----------|----------|--------|
| 47535-09 | 9x9      | 6      |
| 47535-12 | 12x12    | 8      |
| 47535-15 | 15x15    | 10     |
| 47535-17 | 17x17    | 12     |
| 47535-19 | 19x19    | 13     |



SS

**Half sphere**  
Semi-sfera  
Halbkugel  
Demi-sphère  
Semiesfera

| art.     | Ø cm. | h. cm. |
|----------|-------|--------|
| 47536-12 | 12    | 6      |
| 47536-14 | 14    | 7      |
| 47536-16 | 16    | 8      |
| 47536-18 | 18    | 9      |
| 47536-20 | 20    | 10     |



SS

**Crème caramel**  
Crème caramel  
Crème caramel  
Crème caramel  
Molde para flan

| art.     | Ø cm. | h. cm. | ml. |
|----------|-------|--------|-----|
| 41660-10 | 7     | 5      | 150 |
| 41660-15 | 7     | 6      | 180 |







**Piepan, aluminum**

Tortiera, alluminio  
Tortenform, Aluminium  
Tourtière, alu  
Molde, aluminio

| art.     | Ø cm. | h. cm. |
|----------|-------|--------|
| 16940-28 | 28    | 5,0    |
| 16940-32 | 32    | 5,5    |
| 16940-36 | 36    | 6,0    |
| 16940-40 | 40    | 6,5    |



**Savarin tin, aluminum**

Ciambella, alluminio  
Savarinform, Aluminium  
Moule à savarin, alu  
Molde para savarin, aluminio

| art.     | Ø cm. | h. cm. | U. Pack |
|----------|-------|--------|---------|
| 47060-06 | 6,0   | 2,5    | 3       |
| 47060-07 | 7,5   | 3,0    | 3       |
| 47060-09 | 9,0   | 3,5    | 3       |
| 47060-10 | 10,0  | 3,5    | 3       |
| 47060-12 | 12,0  | 5,5    | 3       |
| 47060-14 | 14,0  | 5,5    | 3       |
| 47060-16 | 16,0  | 5,5    | 3       |
| 47060-18 | 18,0  | 6,5    | 3       |
| 47060-20 | 20,0  | 6,5    | 3       |
| 47060-22 | 22,0  | 6,5    | 3       |
| 47060-24 | 24,0  | 8,5    | 3       |
| 47060-26 | 26,0  | 8,5    | 3       |
| 47060-30 | 30,0  | 8,5    | 3       |



**Pandoro mold, aluminum**

Stampo pandoro, alluminio  
Pandoro-Form, Aluminium  
Moule à pandoro, aluminium  
Molde pandoro, aluminio

| art.     | gr.  |
|----------|------|
| 47063-01 | 100  |
| 47063-02 | 250  |
| 47063-05 | 500  |
| 47063-07 | 750  |
| 47063-10 | 1000 |



**Gugelhupf, aluminum**

Stampo americano, alluminio  
Gugelhupfppform, Aluminium  
Moule à gugelhupf, alu  
Molde gugelhupf, aluminio

| art.     | Ø cm. | h. cm. |
|----------|-------|--------|
| 47062-18 | 18    | 10,5   |
| 47062-20 | 20    | 11,0   |
| 47062-22 | 22    | 12,0   |



**Plumcake, aluminum**

Plumcake, alluminio  
Plumcake, Aluminium  
Plumcake, alu  
Molde para plumcake, aluminio

| art.     | dim. cm. |
|----------|----------|
| 47064-18 | 18x80x6  |
| 47064-22 | 22x90x7  |
| 47064-26 | 26x10x8  |
| 47064-30 | 30x11x9  |



**Beaker shaped tin, aluminum**

Stampo per babà, alluminio  
Timbalform, Aluminium  
Moule à dariole, alu  
Molde, aluminio

| art.     | Ø cm. | h. cm. | U. Pack |
|----------|-------|--------|---------|
| 47066-03 | 3     | 3,5    | 10      |
| 47066-04 | 4     | 4,5    | 10      |
| 47066-05 | 5     | 5,5    | 10      |
| 47066-06 | 6     | 6,0    | 10      |
| 47066-07 | 7     | 7,0    | 10      |
| 47066-08 | 8     | 8,0    | 10      |



**Crème caramel, aluminum**

Crème caramel, alluminio  
Crème caramel, Aluminium  
Crème caramel, alu  
Molde crème caramel, aluminio

| art.     | Ø cm. | h. cm. | U. Pack |
|----------|-------|--------|---------|
| 41659-06 | 6     | 4,8    | 6       |
| 41659-07 | 7     | 5,0    | 6       |
| 41659-08 | 8     | 5,3    | 6       |



**Cassata mold, aluminum**

Stampo cassata, alluminio  
Cassataform, Aluminium  
Moule à cassata, alu  
Molde para cassata, aluminio

| art.     | Ø cm. | h. cm. |
|----------|-------|--------|
| 47068-12 | 12    | 10     |
| 47068-15 | 15    | 12     |



**Zuccotto mold, aluminum**

Stampo per zuccotto, alluminio  
Zuccottoform, Aluminium  
Moule à zuccotto, alu  
Molde para zuccotto, aluminio

| art.     | Ø cm. |
|----------|-------|
| 47069-10 | 10    |
| 47069-12 | 12    |
| 47069-14 | 14    |
| 47069-16 | 16    |
| 47069-18 | 18    |
| 47069-20 | 20    |

**MODULAR SYSTEM BASE=LID EXTENSIBLE HEIGHT**  
**SISTEMA MODULARE BASE=COPERCHIO ALTEZZA ESTENSIBILE**



Modular system, the base and lid are the same element and due to the extender insert it is possible to increase capacity. Equipped with rotation system that allows steam to escape. On request dimensions 80x80 cm.

Sistema modulare, base e coperchio sono lo stesso elemento e grazie all'inserto estensore è possibile aumentare la capacità. Provvisto di sistema rotabile, per la fuoriuscita del vapore. A richiesta nelle dimensioni 80x80 cm.



**Base and lid**

Base e coperchio  
 Basis und Abdeckung  
 Base et couvercle  
 Base y tapa

| art.     | cm. ext.  | cm. int.      |
|----------|-----------|---------------|
| 44975-35 | 41x41x7,5 | 35,2x35,2x4,5 |
| 44975-50 | 57x57x9,5 | 51x51x6,3     |

**Extensor**

Estensore  
 Aufsatz  
 Réhausse  
 Extensión

| art.     | cm. ext.  | cm. int.      |
|----------|-----------|---------------|
| 44975H35 | 41x41x7,5 | 35,2x35,2x7,5 |
| 44975H50 | 57x57x9,5 | 51x51x7,5x9,5 |



# NON STICK CAKE MOLDS TORTIERE ANTIADERENTI

PASTRY  
PASTICCERIA



Wash the mold before the first use. Slightly grease inside surface with oil, butter or margarine before baking. Allow cake to cool down a little before removing from the mold. For the cleaning, hand-wash with dish soap and dry the mold immediately after washing. Use only in traditional ovens (no microwave). Do not use sharp objects or others metal tools which could damage the pan surface. Do not use on a flame or other direct heat source, including stove tops. Do not exceed 230°C. Non-stick coating PFOA free.

Lavare lo stampo prima di utilizzarlo la prima volta. Ungere leggermente l'interno con olio, burro o margarina prima di infornare. Prima di sfornare, lasciare raffreddare per qualche minuto. Lavare a mano con detersivi liquidi ed asciugare lo stampo immediatamente dopo. Utilizzare esclusivamente in forni tradizionali (no microonde). Non utilizzare oggetti appuntiti, polveri abrasive o pagliette metalliche che possano rigare la superficie degli stampi. Evitare il contatto con fonti di calore dirette o fiamma libera. Non superare la temperatura massima di 230°C. Rivestimento antiaderente privo di PFOA.



**Pine mold**

Tortiera pino  
Tannenbaumform  
Tourtière pin

**Molde pino**

| art.     | dim. cm.  |
|----------|-----------|
| 47005-24 | 17x24x8,5 |



**Star mold**

Tortiera stella  
Sternform  
Tourtière étoile

**Molde estrella**

| art.     | dim. cm.  |
|----------|-----------|
| 47006-25 | 25x25x4,5 |



**Crispy tart pan**

Tortiera forata  
Tortenform, gelocht  
Tourtière perforée

**Molde perforado**

| art.     | Ø cm. | h. cm. |
|----------|-------|--------|
| 41729-30 | 29/27 | 1,5    |
| 41729-34 | 33/30 | 1,5    |



**Round cake tin**

Tortiera tonda  
Tortenform, rund  
Tourtière ronde

**Molde redondo**

| art.     | Ø cm. | h. cm. | U. Pack |
|----------|-------|--------|---------|
| 47739-12 | 12    | 2,1    | 6       |
| 47739-24 | 24    | 2,3    | 1       |
| 47739-28 | 28    | 2,3    | 1       |
| 47739-32 | 32    | 2,5    | 1       |



**Round cake tin**

Tortiera tonda  
Tortenform, rund  
Manqué rond uni

**Molde redondo**

| art.     | Ø cm. | h. cm. |
|----------|-------|--------|
| 47710-12 | 12    | 3,0    |
| 47710-16 | 16    | 4,0    |
| 47710-20 | 20    | 4,5    |
| 47710-24 | 24    | 5,0    |
| 47710-28 | 28    | 5,0    |
| 47710-32 | 32    | 5,5    |



**Round mold, fluted edges**

Tortiera festonata  
Runde Obsttortenform  
Tourtière ronde bord cannelé

**Molde rizado**

| art.     | Ø cm. | h. cm. |
|----------|-------|--------|
| 47709-20 | 20    | 2,5    |
| 47709-24 | 24    | 2,5    |
| 47709-28 | 28    | 2,5    |
| 47709-32 | 32    | 2,5    |



**Round mold, fluted, loose bottom**

Tortiera festonata, fondo mobile  
Tortenform, gewellter Rand, Heheboden  
Tourtière cannelée, fond amovible

**Molde acanalado, rizado, fondo desmontable**

| art.     | Ø cm. | h. cm. |
|----------|-------|--------|
| 47712-20 | 20    | 2,5    |
| 47712-24 | 24    | 2,5    |
| 47712-28 | 28    | 2,5    |
| 47712-32 | 32    | 2,5    |



**Savarin tin**

Ciambella  
Savarinform  
Moule pour savarin

**Molde Savarin**

| art.     | Ø cm. | h. cm. | U. Pack |
|----------|-------|--------|---------|
| 47711-08 | 8     | 2,0    | 6       |
| 47711-12 | 12    | 2,5    | 6       |
| 47711-22 | 22    | 4,5    | 1       |
| 47711-24 | 24    | 5,0    | 1       |
| 47711-26 | 26    | 6,2    | 1       |



**Trois Frères cake ring**

Tortiera trois frères  
Frankfurter Kranzform  
Tourtière trois frères

**Molde trois frères**

| art.     | Ø cm. | h. cm. |
|----------|-------|--------|
| 47713-22 | 22    | 5,5    |







**Gugelhupf cake pan**

Stampo americano  
Gugelhupfppform  
Moule à gugelhupf  
Molde gugelhupf

| art.     | Ø cm. | h. cm. |
|----------|-------|--------|
| 47705-22 | 22    | 10     |



**Loaf pan**

Tortiera rettangolare  
Königskuchenform  
Cake embouti  
Molde rectangular

| art.     | dim. cm.   |
|----------|------------|
| 47714-26 | 26x9,5x7,5 |
| 47714-28 | 28x10x7,5  |



**Rectangular mold, loose plate bottom**

Tortiera, fondo mobile  
Backform, gerippt, Heheboden  
Tourtière cannelée, fond amovible  
Molde fondo desmontable

| art.     | dim. cm.  |
|----------|-----------|
| 47717-35 | 35x11x2,5 |



**Square mold, fluted, loose bottom**

Tortiera festonata, fondo mobile  
Tortenform, gewellter Rand, Heheboden  
Tourtière carrée, cannelée, fond amovible  
Molde cuadrado, rizado, fondo desmontable

| art.     | dim. cm.  |
|----------|-----------|
| 47738-23 | 23x23x2,5 |



**Baking mold Daisy**

Tortiera margherita  
Margheriten-Backform  
Moule à marguerite  
Molde margarita

| art.     | Ø cm. | h. cm. |
|----------|-------|--------|
| 47718-20 | 20    | 6      |



**Round mold, fluted, loose bottom**

Tortiera festonata, fondo mobile  
Tortenform, gewellter Rand, Heheboden  
Tourtière cannelée, fond amovible  
Molde acanalado, fondo desmontable

| art.     | Ø cm. | h. cm. | U. Pack |
|----------|-------|--------|---------|
| 47719-10 | 10    | 3      | 6       |
| 47719-24 | 25    | 5      | 1       |



**Round mold, fluted, loose bottom**

Tartelletta festonata, fondo mobile  
Runde, gewellte Tortellets, Heheboden  
Tartelette ronde cannelée, fond amovible  
Molde redondo rizado, fondo desmontable

| art.     | Ø cm. | h. cm. | U. Pack |
|----------|-------|--------|---------|
| 47758-10 | 10    | 1,8    | 6       |
| 47758-12 | 12    | 2,0    | 6       |



**Charlotte mold**

Charlotte  
Charlotte-Form  
Charlotte  
Molde Charlotte

| art.     | Ø cm. | h. cm. | U. Pack |
|----------|-------|--------|---------|
| 47734-18 | 18    | 10     | 6       |



**Bavaois mold**

Bavarese  
Bayerische-Kuchenform  
Moule Bavaois  
Molde Bávaro

| art.     | Ø cm. | h. cm. |
|----------|-------|--------|
| 47735-18 | 18    | 9      |



**Rectangular cake mold**

Tortiera rettangolare  
Königskuchenform  
Cake évasé  
Molde ensanchado

| art.     | dim. cm.   |
|----------|------------|
| 47733-18 | 18x7,5x6,5 |
| 47733-24 | 24x9x7,5   |
| 47733-30 | 30x10x8    |
| 47733-36 | 36x10,5x8  |



**Folding loaf pan**

Tortiera rettangolare apribile  
Aufklappbare-Königskuchenform  
Cake ouvrant  
Molde rectangular desmontable

| art.     | dim. cm.  |
|----------|-----------|
| 47715-30 | 30x10x7,5 |





**Loaf pan with hinges, loose bottom**  
Bacinella paté con cerniera, fondo mobile  
Springkastenform, Hebeboden  
Pâté à charnière, fond démontable  
Molde con bisagra, fondo desmontable

| art.     | dim. cm. |
|----------|----------|
| 47736-30 | 30x8x8   |
| 47736-35 | 35x8x8   |
| 47736-40 | 40x8x8   |
| 47736-50 | 50x8x8   |



**Mini paté mold**  
Stampo mini-paté  
Pastetenkastenform  
Mini-pâté à croûte  
Molde minipaté

| art.     | dim. cm. |
|----------|----------|
| 47018-30 | 30x4x6   |
| 47018-50 | 50x4x6   |



**Loaf pan**  
Stampo carré  
Königskuchenform  
Cake évasé  
Molde ensanchado

| art.     | dim. cm.   |
|----------|------------|
| 47752-09 | 9x6x3,4    |
| 47752-16 | 14x6,5x4   |
| 47752-21 | 17x9,5x5,5 |



**Fluted loaf pan**  
Stampo carré, fondo festonato  
Königskuchenform, gerippt  
Cake évasé, fond cannelé  
Molde ensanchado, fondo rizado

| art.     | dim. cm. |
|----------|----------|
| 47753-31 | 31x12x5  |



**Baguette baking pan**  
Teglia baguettes  
Baguetteform  
Plaque à baguettes  
Placa para baguettes

| art.     | dim. cm.    |
|----------|-------------|
| 47014-35 | 35x24,5x2,5 |



**Oval aspic mold**  
Aspic ovale  
Ovale Aspickform  
Aspic ovale  
Molde oval

| art.     | dim. cm.    | U. Pack |
|----------|-------------|---------|
| 47726-07 | 7,5x5,5x3,8 | 6       |



**Oval aspic mold, star bottom**  
Aspic ovale, fondo stella  
Ovale Aspickform, Sternboden  
Aspic ovale, étoilé  
Molde oval, fondo estrella

| art.     | dim. cm.    | U. Pack |
|----------|-------------|---------|
| 47727-07 | 7,5x5,5x3,8 | 6       |



**Rum baba mold**  
Stampo babà  
Runde Babaform  
Dariole embouti  
Molde para babà

| art.     | Ø cm. | h. cm. | U. Pack |
|----------|-------|--------|---------|
| 47728-06 | 6     | 6      | 6       |



**Wine leaf tart mold**  
Tartelletta foglia di vite  
Törtchenform Weinblatt  
Tartelette feuille vigne  
Molde pasteles

| art.     | Ø mm. | h. cm. | U. Pack |
|----------|-------|--------|---------|
| 47760-12 | 12    | 2      | 6       |



**Oak leaf tart mold**  
Tartelletta foglia di quercia  
Törtchenform Eichenblatt  
Tartelette feuille chêne  
Molde pasteles

| art.     | Ø cm. | h. cm. | U. Pack |
|----------|-------|--------|---------|
| 47759-12 | 12    | 2      | 6       |



**Savarin mold**  
Tartelletta savarin  
Savarinförmchen  
Savarin  
Molde savarin

| art.     | Ø mm. | h. cm. | U. Pack |
|----------|-------|--------|---------|
| 47757-65 | 6,5   | 1,5    | 6       |
| 47757-80 | 8,0   | 2,0    | 6       |



**Oval boat mold**  
Tartelletta barchetta  
Schiffchenförmchen  
Barquette unie  
Molde barquilla

| art.     | dim. cm.   | U. Pack |
|----------|------------|---------|
| 47720-06 | 6x2x1      | 6       |
| 47720-08 | 8x3,3x1,2  | 6       |
| 47720-10 | 10x4,3x1,3 | 6       |
| 47720-12 | 12x5x1,3   | 6       |



**Fluted oval boat mold**

Tartelletta barchetta, festonata  
Schiffchenförmchen, gerippt  
Barquette, cannelée  
Molde barquilla, rizado

| art.     | dim. cm.   | U. Pack |
|----------|------------|---------|
| 47721-08 | 8x4x1,2    | 6       |
| 47721-10 | 10x4,5x1,2 | 6       |
| 47721-12 | 12x5x1,4   | 6       |



**Round plain mold**

Tartelletta tonda  
Backförmchen, rund  
Tartelette ronde, unie  
Molde redondo

| art.     | Ø cm. | U. Pack |
|----------|-------|---------|
| 47722-05 | 5     | 6       |
| 47722-06 | 6     | 6       |
| 47722-07 | 7     | 6       |
| 47722-08 | 8     | 6       |
| 47722-10 | 10    | 6       |



**Round fluted mold**

Tartelletta tonda festonata  
Backförmchen, rund, gerippt  
Tartelette ronde, cannelée  
Molde redondo, rizado

| art.     | Ø cm. | U. Pack |
|----------|-------|---------|
| 47723-05 | 5     | 6       |
| 47723-06 | 6     | 6       |
| 47723-07 | 7     | 6       |
| 47723-08 | 8     | 6       |
| 47723-10 | 10    | 6       |
| 47723-12 | 12    | 6       |



**Brioche mold**

Tartelletta a brioche  
Brioche-Förmchen  
Tartelette brioche  
Molde brioche

| art.     | Ø cm. | U. Pack |
|----------|-------|---------|
| 47724-06 | 6     | 6       |
| 47724-08 | 8     | 6       |
| 47724-10 | 10    | 6       |
| 47724-11 | 11    | 6       |



**Box of small assorted molds**

Scatola tartellette assortite  
Satz Förmchen  
Boîte petits fours, assortis  
Surtido moldes

| art.     | pcs/pz |
|----------|--------|
| 47730-60 | 60     |



**Friand mold**

Tartelletta rettangolare  
Friand-Förmchen  
Friand  
Molde rectangular

| art.     | dim. cm. | U. Pack |
|----------|----------|---------|
| 47725-09 | 10x5x1,4 | 6       |



**Small mold**

Tartelletta  
Törtchenform  
Petit four  
Molde pasteles

| art.     | dim. cm. | U. Pack |
|----------|----------|---------|
| 47747-03 | 4,5x3    | 6       |



**Small mold**

Tartelletta  
Törtchenform  
Petit four  
Molde pasteles

| art.     | dim. cm. | U. Pack |
|----------|----------|---------|
| 47747-06 | 6x3      | 6       |



**Small mold**

Tartelletta  
Törtchenform  
Petit four  
Molde pasteles

| art.     | Ø cm. | h. cm. | U. Pack |
|----------|-------|--------|---------|
| 47747-10 | 4,0   | 1,0    | 6       |
| 47747-11 | 3,5   | 1,4    | 6       |



**Small mold**

Tartelletta  
Törtchenform  
Petit four  
Molde pasteles

| art.     | Ø cm. | U. Pack |
|----------|-------|---------|
| 47747-01 | 4,5   | 6       |



**Small mold**

Tartelletta  
Törtchenform  
Petit four  
Molde pasteles

| art.     | dim. cm. | U. Pack |
|----------|----------|---------|
| 47747-04 | 3,5x3,5  | 6       |



**Small mold**  
Tartelletta  
Törtchenform  
Petit four  
Molde pasteles

| art.     | dim. cm. | U. Pack |
|----------|----------|---------|
| 47747-07 | 6x3      | 6       |



**Small mold**  
Tartelletta  
Törtchenform  
Petit four  
Molde pasteles

| art.     | Ø cm. | U. Pack |
|----------|-------|---------|
| 47723-05 | 5     | 6       |



**Small mold**  
Tartelletta  
Törtchenform  
Petit four  
Molde pasteles

| art.     | dim. cm. | U. Pack |
|----------|----------|---------|
| 47747-05 | 4,5x2,5  | 6       |



**Small mold**  
Tartelletta  
Törtchenform  
Petit four  
Molde pasteles

| art.     | dim. cm. | U. Pack |
|----------|----------|---------|
| 47747-09 | 5x3      | 6       |



**Madeleine sheet**  
Stampo per madeleines  
Madeleine-Backblech  
Plaque madeleines  
Molde Madeleine

| art.     | dim. cm. |
|----------|----------|
| 47731-12 | 26x20    |

**Pcs/Pz 12 - 7x4,2 cm.**



**Madeleinette sheet**  
Stampo per madeleinettes  
Madeleinette-Backblech  
Plaque madeleinettes  
Molde Madeleine

| art.     | dim. cm.  |
|----------|-----------|
| 47732-20 | 39,5x12,5 |

**Pcs/Pz 20 - 4,2x3 cm.**



**Cup bun pan**  
Stampo tartellette  
Backblech  
Plaque tartelettes  
Molde pasteles

| art.     | Ø cm. | dim. cm.    |
|----------|-------|-------------|
| 47748-35 | 6,5   | 35,5x27x2,5 |



**Snowman mold**  
Stampo pupazzo di neve  
Schneemann-Backblech  
Plaque bonhomme de neige  
Molde muñeco de nieve

| art.     | dim. cm. |
|----------|----------|
| 47762-23 | 23x5     |



**Christmas style mold**  
Stampo di Natale  
Weihnachts-Backblech  
Plaque de Noël  
Molde de Noël

| art.     | dim. cm.      |
|----------|---------------|
| 47750-06 | 31,5x21,5x2,5 |



**Santa Claus mold**  
Stampo Babbo Natale  
Weihnachtsmann-Backblech  
Plaque Père Noël  
Molde Papà Noel

| art.     | dim. cm. |
|----------|----------|
| 47761-23 | 23x4,8   |



**Easter muffin pan**  
Stampo motivi pasquali  
Ostern-Backblech  
Plaque Pâque  
Molde Pascua

| art.     | dim. cm. |
|----------|----------|
| 47749-35 | 35x27x3  |



**Egg mold**  
Stampo uovo  
Ostereierform  
Moule à oeuf  
Molde para huevos

| art.     | dim. cm. |
|----------|----------|
| 47007-26 | 26x8,3   |







**Easter rabbit mold**

Stampo coniglietto di Pasqua  
Osternhase-Backblech  
Plaque lapin de Pâque  
Molde conejo de Pascua

| art.     | dim. cm. |
|----------|----------|
| 47764-12 | 12x2,6   |



**Easter rabbit mold**

Stampo coniglio di Pasqua  
Osternhase-Backblech  
Plaque lapin de Pâque  
Molde conejo de Pascua

| art.     | dim. cm. |
|----------|----------|
| 47764-28 | 28x5,4   |



**Fluted springform pan**

Stampo ciambella apribile  
Savarinspringform  
Manqué savarin démontable  
Molde savarin desmontable

| art.     | Ø cm. | h. cm. |
|----------|-------|--------|
| 47756-20 | 20,5  | 4,7    |
| 47756-24 | 24,0  | 6,8    |
| 47756-26 | 26,0  | 6,5    |
| 47756-28 | 28,0  | 6,7    |



**Springform mold with 6 bottoms**

Stampo apribile, 6 fondi  
Springform mit 6 Böden  
Manqué démontable, 6 fonds  
Molde desmontable, 6 fondos

| art.     | Ø cm. | h. cm. |
|----------|-------|--------|
| 47755-26 | 26    | 6      |



**Springform mold**

Stampo apribile  
Springform  
Manqué démontable  
Molde desmontable

| art.     | Ø cm. | h. cm. |
|----------|-------|--------|
| 47754-20 | 20,5  | 6,5    |
| 47754-24 | 24,0  | 6,5    |
| 47754-26 | 26,0  | 6,5    |
| 47754-28 | 28,0  | 6,7    |



**Rubber comb, wood effect**

Tampone finto legno  
Kamm aus Kunststoff, holzartig  
Peigne faux bois  
Peine de goma, efecto madera

| art.     | cm. |
|----------|-----|
| 47684-15 | 15  |



**Log mold, plastic**

Stampo per tronco, plastica  
Kastenform, Kunststoff  
Gouttière, plastique  
Molde, plástico

| art.     | dim. cm. |
|----------|----------|
| 47659-01 | 48x6,5x7 |
| 47659-02 | 48x6,5x7 |
| 47659-03 | 48x6,5x7 |
| 47659-04 | 48x5,0x4 |

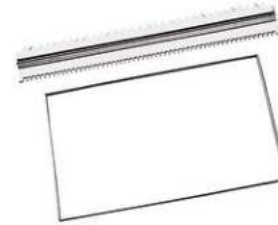

**Comb for Charlotte with frame**

Pettine Charlotte con telaio  
Charlotte-Kamme mit Rahmen  
Peigne à Charlotte avec cadre  
Peine para Charlotte con marco

| art.     | dim. cm. |
|----------|----------|
| 47670-02 | 57x36,5  |



**Comb with 5 rubber blades**

Pettine con 5 fasce gomma  
Kamm mit 5 Gummiklingen  
Peigne avec 5 bandes à décor  
Peine con 5 láminas de goma

| art.     | dim. cm. |
|----------|----------|
| 47672-05 | 70x10    |



SS

SS

MONOPORTION TRAY MOLDS  
TEGLIE MONOPORZIONI



**Tray cm. 60x40**

Teglia  
Blech  
Plaque  
Bandeja

| art.     | dim. mm.  | gr. | pcs/pz |
|----------|-----------|-----|--------|
| 47651-01 | Ø 44 h 25 | 20  | 96     |
| 47651-02 | 55x35x25  | 20  | 96     |
| 47651-03 | 46x46x25  | 20  | 96     |
| 47651-04 | 60x38x25  | 20  | 96     |
| 47651-05 | 58x39x25  | 20  | 96     |
| 47651-07 | 38x38x25  | 20  | 96     |

**Extractor**

Estrattore  
Extraktor  
Extracteur  
Extractor

| art.     | dim. mm.  |
|----------|-----------|
| 47656-01 | Ø 44 h 25 |
| 47656-02 | 55x35x25  |
| 47656-03 | 46x46x25  |
| 47656-04 | 60x38x25  |
| 47656-05 | 58x39x25  |
| 47656-07 | 38x38x25  |



**Cutter**

Tagliapasta  
Ausstechform  
Coupe-pâte  
Cortador

| art.     | dim. mm.  |
|----------|-----------|
| 47655-01 | Ø 44 h 25 |
| 47655-02 | 55x35x25  |
| 47655-03 | 46x46x25  |
| 47655-04 | 60x38x25  |
| 47655-05 | 58x39x25  |
| 47655-07 | 38x38x25  |

**Tray cm. 60x40**

Teglia  
Blech  
Plaque  
Bandeja

| art.     | dim. mm.  | gr. | pcs/pz |
|----------|-----------|-----|--------|
| 47652-01 | Ø 67 h 40 | 75  | 35     |
| 47652-02 | 86x50x40  | 75  | 35     |
| 47652-03 | 74x71x40  | 75  | 35     |
| 47652-04 | 90x58x40  | 75  | 35     |
| 47652-05 | 88x60x40  | 75  | 35     |
| 47652-07 | 59x59x40  | 75  | 35     |



**Estrattore**

Estrattore  
Extraktor  
Extracteur  
Extractor

| art.     | dim. mm.  |
|----------|-----------|
| 47658-01 | Ø 67 h 40 |
| 47658-02 | 86x50x40  |
| 47658-03 | 74x71x40  |
| 47658-04 | 90x58x40  |
| 47658-05 | 88x60x40  |
| 47658-07 | 59x59x40  |

**Cutter**

Tagliapasta  
Ausstechform  
Coupe-pâte  
Cortador

| art.     | dim. mm.  |
|----------|-----------|
| 47657-01 | Ø 67 h 40 |
| 47657-02 | 86x50x40  |
| 47657-03 | 74x71x40  |
| 47657-04 | 90x58x40  |
| 47657-05 | 88x60x40  |
| 47657-07 | 59x59x40  |





**Stencil cm. 31x51**

| art.     | dim. cm. | pcs/pz |
|----------|----------|--------|
| 47875-11 | 13x3     | 30     |



**Stencil cm. 31x51**

| art.     | dim. cm. | pcs/pz |
|----------|----------|--------|
| 47875-13 | 7,5x3,5  | 40     |



**Stencil cm. 31x51**

| art.     | dim. cm. | pcs/pz |
|----------|----------|--------|
| 47875-14 | 6,5x4    | 32     |

**PRALINE'S SILICONE MOLDS CM 19X29**  
STAMPI IN SILICONE PER PRALINE CM 19X29



**Practical, flexible and resistant silicone molds for sweet or salty creations (snaks, truffles, jellies, pralines). Perfect to make large quantities in short time. They withstand from -40° to +250°C. Can be used in the oven, refrigerator and blast chiller.**

Pratici stampi in silicone flessibili e resistenti per creazioni dolci o salate (snack, tartufi, gelatine, praline). Ideali per realizzare grandi quantità in poco tempo. Resistono da -40° a +250°C. Utilizzabili in forno, frigorifero e abbattitore.

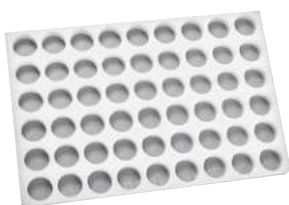

**Chocoflex - psc/pz 54**

| art.     | Ø mm. | h. |
|----------|-------|----|
| 47783-01 | 26    | 14 |



**Chocoflex - psc/pz 54**

| art.     | dim. mm. |
|----------|----------|
| 47783-02 | 23x23x14 |

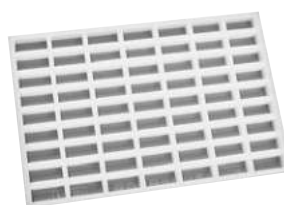

**Chocoflex - psc/pz 63**

| art.     | dim. mm.   |
|----------|------------|
| 47783-03 | 35x14,5x14 |

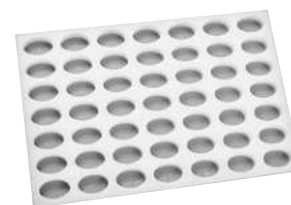

**Chocoflex - psc/pz 49**

| art.     | dim. mm. |
|----------|----------|
| 47783-04 | 32x21x14 |

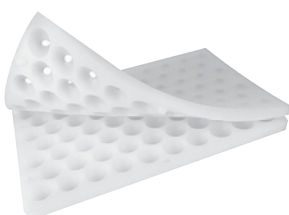

**Chocoflex - psc/pz 54**

| art.     | Ø mm. | h. |
|----------|-------|----|
| 47783-11 | 26    | 14 |

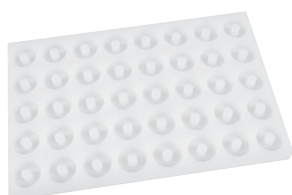

**Chocoflex - psc/pz 40**

| art.     | Ø mm. | h. |
|----------|-------|----|
| 47783-12 | 30-10 | 12 |



**Chocoflex - psc/pz 15**

| art.     | dim. mm. |
|----------|----------|
| 47783-13 | 90x30x19 |



**Chocoflex - psc/pz 15**

| art.     | dim. mm. |
|----------|----------|
| 47783-14 | 90x30x19 |



CHOCOLATE  
CIOCCOLATO

PC

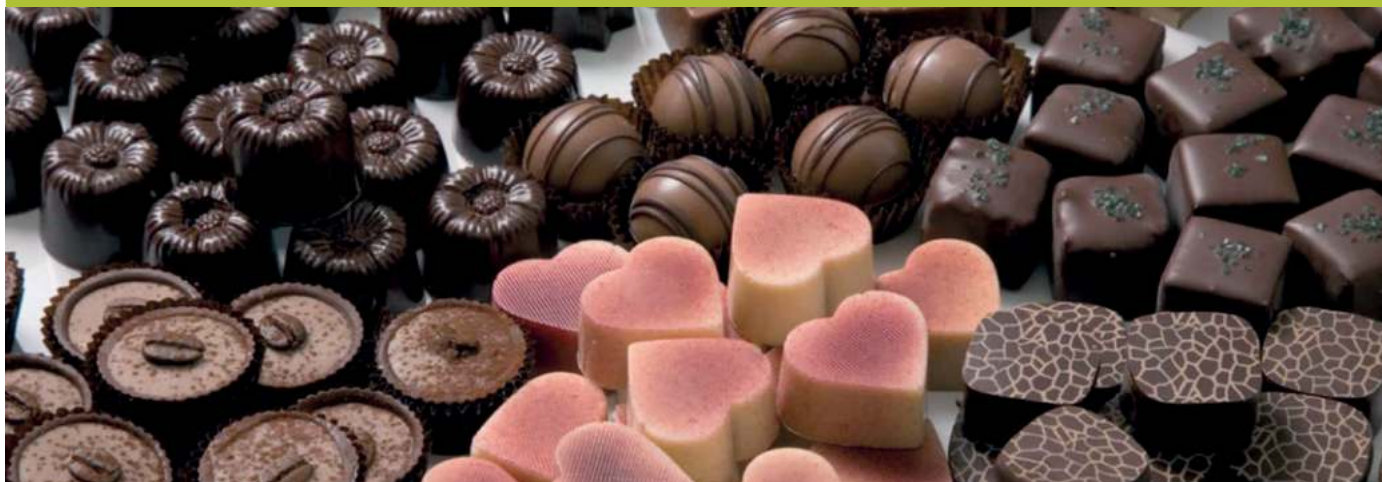

Polycarbonate chocolate molds. Mold size 17,5x27,5 cm.

Stampi policarbonato. Misure stampo 17,5x27,5 cm.



Chocolate/Ciocolato Praline

| art.     | dim. mm. | pcs/pz |
|----------|----------|--------|
| 47861-02 | 50x25x15 | 21     |



Chocolate/Ciocolato Praline

| art.     | dim. mm. | pcs/pz |
|----------|----------|--------|
| 47861-03 | 30x30x8  | 24     |



Chocolate/Ciocolato Praline

| art.     | Ø mm. | h. | pcs/pz |
|----------|-------|----|--------|
| 47861-04 | 35    | 8  | 24     |



Chocolate/Ciocolato Praline

| art.     | dim. mm. | pcs/pz |
|----------|----------|--------|
| 47861-05 | 33x33x15 | 24     |



Chocolate/Ciocolato Praline

| art.     | dim. mm.   | pcs/pz |
|----------|------------|--------|
| 47861-07 | 39x18x15,5 | 30     |
| 47861-08 | 96x22x15,5 | 10     |



Chocolate/Ciocolato Praline

| art.     | dim. mm.   | pcs/pz |
|----------|------------|--------|
| 47861-09 | 39x18x15,5 | 30     |
| 47861-10 | 96x22x17   | 10     |



Chocolate/Ciocolato Praline

| art.     | dim. mm. | pcs/pz |
|----------|----------|--------|
| 47861-11 | 39x20x16 | 27     |
| 47861-06 | 96x22x17 | 10     |



Chocolate/Ciocolato Praline

| art.     | dim. mm. | pcs/pz |
|----------|----------|--------|
| 47861-12 | 52x26x14 | 21     |



Chocolate/Ciocolato Praline

| art.     | dim. mm. | pcs/pz |
|----------|----------|--------|
| 47861-13 | 42x25x6  | 20     |



Chocolate/Ciocolato Praline

| art.     | dim. mm.  | pcs/pz |
|----------|-----------|--------|
| 47861-14 | 123x27x12 | 8      |



Chocolate/Ciocolato Praline

| art.     | dim. mm.  | pcs/pz |
|----------|-----------|--------|
| 47861-15 | 138x72x11 | 3      |



Chocolate/Ciocolato Praline

| art.     | dim. mm. | pcs/pz |
|----------|----------|--------|
| 47860-17 | 30x30x12 | 24     |







Chocolate/Cioccolato Praline

| art.     | Ø mm. | h. | pcs/pz |
|----------|-------|----|--------|
| 47860-18 | 27    | 17 | 24     |



Chocolate/Cioccolato Praline

| art.     | Ø mm. | h. | pcs/pz |
|----------|-------|----|--------|
| 47860-21 | 29    | 18 | 24     |



Chocolate/Cioccolato Praline

| art.     | dim. mm. | pcs/pz |
|----------|----------|--------|
| 47860-24 | 40x42x15 | 15     |



Chocolate/Cioccolato Praline

| art.     | dim. mm. | pcs/pz |
|----------|----------|--------|
| 47860-27 | 27x27x13 | 28     |



Chocolate/Cioccolato Praline

| art.     | dim. mm. | pcs/pz |
|----------|----------|--------|
| 47860-31 | 33x25x12 | 24     |



Chocolate/Cioccolato Praline

| art.     | Ø mm. | h. | pcs/pz |
|----------|-------|----|--------|
| 47860-35 | 30    | 19 | 28     |



Chocolate/Cioccolato Praline

| art.     | dim. mm. | h. | pcs/pz |
|----------|----------|----|--------|
| 47860-36 | 25x25x25 | 25 | 40     |



Chocolate/Cioccolato Praline

| art.     | dim. mm. | pcs/pz |
|----------|----------|--------|
| 47860-37 | 36x22x20 | 36     |



Chocolate/Cioccolato Praline

| art.     | dim. mm.   | pcs/pz |
|----------|------------|--------|
| 47860-38 | 48x18,5x19 | 16     |



Chocolate/Cioccolato Praline

| art.     | dim. mm. | pcs/pz |
|----------|----------|--------|
| 47860-39 | 30x18x15 | 30     |



Chocolate/Cioccolato Praline

| art.     | Ø mm. | h. | pcs/pz |
|----------|-------|----|--------|
| 47860-40 | 29    | 21 | 40     |



Chocolate/Cioccolato Praline

| art.     | dim. mm. | pcs/pz |
|----------|----------|--------|
| 47860-42 | 35x23x16 | 36     |



Chocolate/Cioccolato Praline

| art.     | dim. mm. | pcs/pz |
|----------|----------|--------|
| 47860-43 | 38x28x18 | 30     |



Chocolate/Cioccolato Praline

| art.     | dim. mm. | pcs/pz |
|----------|----------|--------|
| 47860-44 | 28x32x15 | 32     |



Chocolate/Cioccolato Praline

| art.     | dim. mm. | pcs/pz |
|----------|----------|--------|
| 47860-46 | 35x20x17 | 30     |



Chocolate/Cioccolato Praline

| art.     | Ø mm. | h. | pcs/pz |
|----------|-------|----|--------|
| 47860-48 | 28    | 24 | 40     |



Chocolate/Cioccolato Praline

| art.     | Ø mm. | h. | pcs/pz |
|----------|-------|----|--------|
| 47860-49 | 30    | 22 | 28     |



Chocolate/Cioccolato Praline

| art.     | Ø mm. | h. | pcs/pz |
|----------|-------|----|--------|
| 47860-50 | 26    | 15 | 35     |



Chocolate/Ciocolato Praline

| art.     | dim. mm. | pcs/pz |
|----------|----------|--------|
| 47860-53 | 22x22x22 | 28     |



Chocolate/Ciocolato Praline

| art.     | dim. mm. | pcs/pz |
|----------|----------|--------|
| 47860-55 | 26x20x21 | 28     |



Chocolate/Ciocolato Praline

| art.     | Ø mm. | h. | pcs/pz |
|----------|-------|----|--------|
| 47860-56 | 24    | 21 | 28     |



Chocolate/Ciocolato Praline

| art.     | dim. mm. | pcs/pz |
|----------|----------|--------|
| 47860-58 | 17x12x5  | 130    |



Chocolate/Ciocolato Praline

| art.     | Ø mm. | h.   | pcs/pz |
|----------|-------|------|--------|
| 47860-60 | 25    | 18,5 | 28     |



Chocolate/Ciocolato Praline

| art.     | dim. mm.   | pcs/pz |
|----------|------------|--------|
| 47860-61 | 30x20x17,5 | 28     |



Chocolate/Ciocolato Praline

| art.     | Ø mm. | h. | pcs/pz |
|----------|-------|----|--------|
| 47860-62 | 27    | 20 | 30     |



Chocolate/Ciocolato Praline

| art.     | Ø mm. | h. | pcs/pz |
|----------|-------|----|--------|
| 47860-63 | 27    | 20 | 30     |



Chocolate/Ciocolato Praline

| art.     | dim. mm. | pcs/pz |
|----------|----------|--------|
| 47860-66 | 25x25x15 | 30     |



Chocolate/Ciocolato Praline

| art.     | dim. mm. | pcs/pz |
|----------|----------|--------|
| 47860-67 | 25x25x15 | 30     |



Chocolate/Ciocolato Praline

| art.     | Ø mm. | h. | pcs/pz |
|----------|-------|----|--------|
| 47860-68 | 28    | 25 | 40     |



Chocolate/Ciocolato Praline

| art.     | dim. mm. | pcs/pz |
|----------|----------|--------|
| 47860-69 | 40x20x18 | 30     |



Chocolate/Ciocolato Praline

| art.     | dim. mm. | pcs/pz |
|----------|----------|--------|
| 47860-73 | 31x22x22 | 5x6    |



Chocolate/Ciocolato Praline

| art.     | dim. mm. | pcs/pz |
|----------|----------|--------|
| 47860-71 | 26x26x20 | 30     |



Chocolate/Ciocolato Praline

| art.     | dim. mm. | pcs/pz |
|----------|----------|--------|
| 47860-74 | 32x32x4  | 24     |



Chocolate/Ciocolato Praline

| art.     | dim. mm. | pcs/pz |
|----------|----------|--------|
| 47860-70 | 40x18x15 | 30     |





Chocolate/Ciocolato Praline

| art.     | dim. mm. | pcs/pz |
|----------|----------|--------|
| 47860-75 | 20x20x16 | 28     |



Chocolate/Ciocolato Praline

| art.     | dim. mm. | pcs/pz |
|----------|----------|--------|
| 47860-81 | 30x18x15 | 30     |



Chocolate/Ciocolato Praline

| art.     | dim. mm. | pcs/pz |
|----------|----------|--------|
| 47860-83 | 30x30x15 | 24     |



Chocolate/Ciocolato Praline

| art.     | Ø mm. | h. | pcs/pz |
|----------|-------|----|--------|
| 47860-84 | 26    | 19 | 35     |



Chocolate/Ciocolato Praline

| art.     | dim. mm. | pcs/pz |
|----------|----------|--------|
| 47860-85 | 35x22x16 | 35     |



Chocolate/Ciocolato Praline

| art.     | dim. mm. | pcs/pz |
|----------|----------|--------|
| 47860-95 | 25x25x13 | 24     |



Chocolate/Ciocolato Praline

| art.     | Ø mm. | h. | pcs/pz |
|----------|-------|----|--------|
| 47860-96 | 35    | 15 | 24     |



Chocolate/Ciocolato Praline

| art.     | dim. mm. | pcs/pz |
|----------|----------|--------|
| 47862-31 | 28x28x16 | 28     |



Chocolate/Ciocolato Praline

| art.     | dim. mm. | pcs/pz |
|----------|----------|--------|
| 47862-32 | 24x24x18 | 28     |



Chocolate/Ciocolato Praline

| art.     | dim. mm. | pcs/pz |
|----------|----------|--------|
| 47862-33 | 40x42x16 | 15     |



Chocolate/Ciocolato Praline

| art.     | dim. mm. | pcs/pz |
|----------|----------|--------|
| 47862-34 | 41x24x20 | 20     |



Chocolate/Ciocolato Praline

| art.     | dim. mm. | pcs/pz |
|----------|----------|--------|
| 47862-35 | 30x30x11 | 28     |



Chocolate/Ciocolato Praline

| art.     | dim. mm. | pcs/pz |
|----------|----------|--------|
| 47862-36 | 35x23x17 | 24     |



Chocolate/Ciocolato Bars

| art.     | dim. mm. | pcs/pz |
|----------|----------|--------|
| 47862-38 | 50x26x3  | 16     |



Chocolate/Ciocolato Bars

| art.     | dim. mm. | pcs/pz |
|----------|----------|--------|
| 47862-39 | 74x33x5  | 12     |



Polycarbonate molds mm. 275x175. To create small mignon and refined pralines with an original and inviting look.

Stampi in policarbonato mm. 275x175 . Per creare piccoli mignon e raffinate praline dall'aspetto originale e invitante.



Mini choco fill

| art.     | Ø mm. | h. | pcs/pz |
|----------|-------|----|--------|
| 47862-64 | 27    | 31 | 28     |



Mini choco fill

| art.     | Ø mm. | h. | pcs/pz |
|----------|-------|----|--------|
| 47862-65 | 37    | 14 | 15     |



Mini choco fill

| art.     | dim. mm. | pcs/pz |
|----------|----------|--------|
| 47862-66 | 27x27x31 | 28     |



Mini choco fill

| art.     | dim. mm. | pcs/pz |
|----------|----------|--------|
| 47862-67 | 33x33x14 | 24     |



Mini choco fill

| art.     | dim. mm. | pcs/pz |
|----------|----------|--------|
| 47862-03 | 32x24x29 | 24     |



Mini choco fill

| art.     | dim. mm. | pcs/pz |
|----------|----------|--------|
| 47862-04 | 44x56x39 | 12     |



Mini choco fill

| art.     | Ø mm. | h. | pcs/pz |
|----------|-------|----|--------|
| 47862-05 | 40    | 17 | 15     |







Mini choco fill

| art.     | dim. mm. | pcs/pz |
|----------|----------|--------|
| 47862-06 | 33x31x20 | 24     |



Mini choco fill

| art.     | dim. mm. | pcs/pz |
|----------|----------|--------|
| 47862-07 | 33x33x23 | 24     |



Mini choco fill

| art.     | dim. mm. | pcs/pz |
|----------|----------|--------|
| 47862-08 | 44x55x23 | 12     |



Mini choco fill

| art.     | Ø mm. | h.   | pcs/pz |
|----------|-------|------|--------|
| 47862-09 | 40    | 18,5 | 15     |



Mini choco fill

| art.     | Ø mm. | h. | pcs/pz |
|----------|-------|----|--------|
| 47862-10 | 32    | 37 | 20     |



Tray/Vassoio

| art.     | dim. cm.  | pcs/pz |
|----------|-----------|--------|
| 47862C10 | 38x10x2,5 | 20     |



Chocolate/Ciocolato Decoration

| art.     | dim. mm. | gr. | pcs/pz |
|----------|----------|-----|--------|
| 47862-70 | 64x26    | 2/3 | 16     |



Chocolate/Ciocolato Decoration

| art.     | dim. mm. | gr. | pcs/pz |
|----------|----------|-----|--------|
| 47862-71 | 47x39    | 2/3 | 15     |



Chocolate/Ciocolato Decoration

| art.     | dim. mm. | gr. | pcs/pz |
|----------|----------|-----|--------|
| 47862-72 | 110x7    | 3/4 | 22     |



Chocolate/Ciocolato Decoration

| art.     | dim. mm. | gr. | pcs/pz |
|----------|----------|-----|--------|
| 47862-73 | 66x21    | 2/3 | 18     |



Chocolate/Ciocolato Decoration

| art.     | dim. mm. | gr. | pcs/pz |
|----------|----------|-----|--------|
| 47862-74 | 65x22    | 2/3 | 18     |



Chocolate/Ciocolato Decoration

| art.     | dim. mm. | gr. | pcs/pz |
|----------|----------|-----|--------|
| 47862-75 | 71x71    | 2/3 | 18     |



Chocolate/Ciocolato Decoration

| art.     | Ø mm. | gr. | pcs/pz |
|----------|-------|-----|--------|
| 47862-76 | 51>73 | 2/3 | 18     |



Chocolate/Ciocolato Decoration

| art.     | dim. mm. | gr. | pcs/pz |
|----------|----------|-----|--------|
| 47862-77 | 68x81    | 2/3 | 18     |



**Letters & Numbers**

art. h. cm.  
47860-86 3

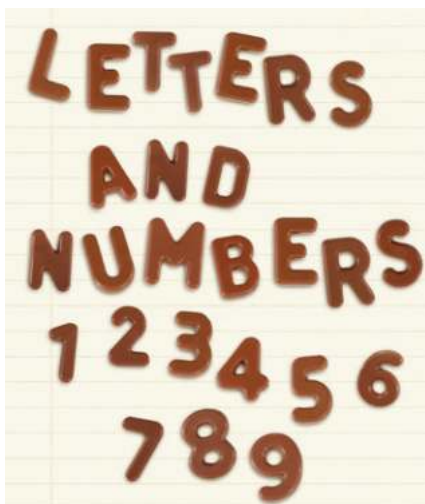

**Spheres/Sfere**

art. Ø mm. pcs/pz  
47861-16 20 45  
47860-76 30 24



**Spheres/Sfere**

art. Ø mm. gr. pcs/pz  
47860-77 50 15 8



**Spheres/Sfere**

art. Ø mm. gr. pcs/pz  
47860-78 100 90 2



PE

**Chocolate bars, set 5 pcs**

Tavolette cioccolato, set 5 pz  
Schokoladentafel, 5 Stk  
Tablettes chocolat, 5 pièces  
Tabletas chocolate, 5 piezas

art. dim. cm. gr.  
47870-17 15x7x1 100



PE

**Chocolate bars, set 5 pcs**

Tavolette cioccolato, set 5 pz  
Schokoladentafel, 5-tlg  
Tablettes chocolat, 5 pièces  
Tabletas chocolate, 5 piezas

art. dim. cm. gr.  
47870-18 15x7x1 100



PE

**Chocolate bars, set 5 pcs**

Tavolette cioccolato, set 5 pz  
Schokoladentafel, 5-tlg  
Tablettes chocolat, 5 pièces  
Tabletas chocolate, 5 piezas

art. dim. cm. gr.  
47870-19 15x7x1 100



PC

**Spoon mold**

Stampo cucchiaino  
Löffelform  
Moule à cuillère  
Molde cuchara

art. dim. mm.  
47860-90 25x95





**Egg mold kit**

Stampo uovo kit  
Ostereierform-Kit  
Moule à oeuf en kit  
Molde para huevo

| art.     | Ø mm. | h.  | gr. | pcs/pz |
|----------|-------|-----|-----|--------|
| 47862-87 | 120   | 185 | 280 | 2      |

**Thermoformed plastic. – Plastica termoformata.**



**Egg mold kit**

Stampo uovo kit  
Ostereierform-Kit  
Moule à oeuf en kit  
Molde para huevo

| art.     | Ø mm. | h.  | gr. | pcs/pz |
|----------|-------|-----|-----|--------|
| 47862-88 | 115   | 155 | 230 | 2      |

**Thermoformed plastic. – Plastica termoformata.**



**Egg mold kit**

Stampo uovo kit  
Ostereierform-Kit  
Moule à oeuf en kit  
Molde para huevo

| art.     | Ø mm. | h.  | gr. | pcs/pz |
|----------|-------|-----|-----|--------|
| 47862-89 | 122   | 185 | 270 | 2      |

**Thermoformed plastic. – Plastica termoformata.**



**Half egg mold, strong plastic (PETG)**

Stampo 1/2 uovo, plastica rigida  
Ostereierform 1/2  
Moule à 1/2 oeuf  
Molde para 1/2 huevo

| art.     | dim. cm. | Kg.     |
|----------|----------|---------|
| 47876-11 | 17x25    | 0,5-1,0 |
| 47876-12 | 18x28    | 0,8-1,2 |
| 47876-13 | 34x25    | 1,5-2,0 |
| 47876-14 | 27x40    | 2,0-2,5 |



**PC**

**Half egg mold**

Stampo 1/2 uovo  
Ostereierform 1/2  
Moule à 1/2 oeuf  
Molde para 1/2 huevo

| art.     | dim. mm. | gr. | pcs/pz |
|----------|----------|-----|--------|
| 47862-80 | 44x64    | 25  | 10     |
| 47862-81 | 75x105   | 70  | 4      |
| 47862-82 | 90x130   | 150 | 2      |
| 47862-83 | 104x150  | 230 | 2      |
| 47862-84 | 121x175  | 260 | 1      |
| 47862-85 | 141x204  | 380 | 1      |
| 47862-86 | 157x227  | 430 | 1      |



**PE**

**Egg mold**

Stampo uovo  
Ostereierform  
Moule à oeuf  
Molde para huevos

| art.     | dim. mm.   | pcs/pz |
|----------|------------|--------|
| 47865-44 | 220x160x85 | 1      |
| 47865-23 | 110x80x40  | 2      |
| 47865-80 | 112x83x44  | 2      |
| 47865-81 | 125x94x44  | 2      |
| 47865-82 | 140x100x50 | 2      |
| 47865-83 | 154x110x55 | 2      |



**PE**

**Egg mold**

Stampo uovo  
Ostereierform  
Moule à oeuf  
Molde para huevos

| art.     | dim. mm. | pcs/pz |
|----------|----------|--------|
| 47865-66 | 80x60x25 | 4      |
| 47865-73 | 40x31x17 | 14     |
| 47865-71 | 36x23x12 | 18     |



**PE**

**Egg mold**

Stampo uovo  
Ostereierform  
Moule à oeuf  
Molde para huevos

| art.     | dim. mm. | pcs/pz |
|----------|----------|--------|
| 47865-74 | 64x44x26 | 6      |
| 47865-72 | 39x25x13 | 14     |



**PE**

**Egg mold**

Stampo uovo  
Ostereierform  
Moule à oeuf  
Molde para huevos

| art.     | dim. mm.   | pcs/pz |
|----------|------------|--------|
| 47865-77 | 140x100x49 | 1      |
| 47865-76 | 95x70x40   | 2      |
| 47865-75 | 83x54x24   | 4      |

3D HOLLOW MOLDS/STAMPI 3D CORPO CAVO  
3D-HOHLFORME/MOULES CREUSES 3D/MOLDE 3D

PC



Easter/Pasqua

| art.     | h. mm. |
|----------|--------|
| 47793-11 | 170    |



Easter/Pasqua

| art.     | h. mm. |
|----------|--------|
| 47793-12 | 180    |



Easter/Pasqua

| art.     | h. mm. |
|----------|--------|
| 47793-13 | 140    |



Easter/Pasqua

| art.     | h. mm. | # |
|----------|--------|---|
| 47793-15 | 170    | 2 |



Easter/Pasqua

| art.     | h. mm. |
|----------|--------|
| 47793-16 | 150    |



Easter/Pasqua

| art.     | h. mm. |
|----------|--------|
| 47793-18 | 205    |



Easter/Pasqua

| art.     | h. mm. |
|----------|--------|
| 47793-20 | 160    |



Easter/Pasqua

| art.     | h. mm. | # |
|----------|--------|---|
| 47793-23 | 110    | 3 |



Easter/Pasqua

| art.     | h. mm. |
|----------|--------|
| 47793-26 | 110    |



Christmas/Natale

| art.     | h. mm. | # |
|----------|--------|---|
| 47793-32 | 122    | 3 |



Christmas/Natale

| art.     | h. mm. |
|----------|--------|
| 47793-33 | 180    |



Christmas/Natale

| art.     | h. mm. |
|----------|--------|
| 47793-40 | 168    |



Christmas/Natale

| art.     | h. mm. | # |
|----------|--------|---|
| 47793-43 | 114    | 3 |



Christmas/Natale

| art.     | h. mm. |
|----------|--------|
| 47793-45 | 135    |



Ball/Pallone

| art.     | h. mm. |
|----------|--------|
| 47793-52 | 120    |



Shoe/Scarpa

| art.     | dim. mm.   |
|----------|------------|
| 47793-55 | 220x75x170 |





**FRUITS/TUTTIFRUTTI CM 40X30**

Silicone molds cm 40x30, to create original dessert and surprising monoportions.

Stampi in silicone cm 40x30, per realizzare dessert al piatto e monoporzioni.

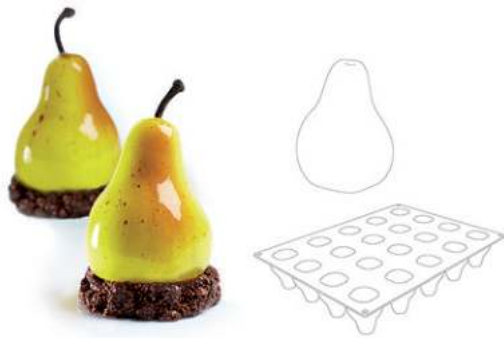

**Pear**

**Pera**

| art.     | Ø mm. | h. | ml. | pcs/pz |
|----------|-------|----|-----|--------|
| 47745-06 | 53    | 70 | 90  | 20     |

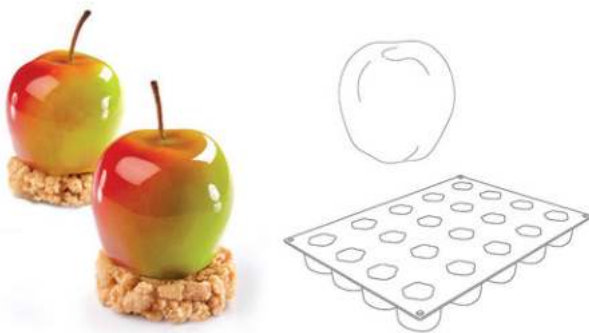

**Apple**

**Mela**

| art.     | Ø mm. | h. | ml. | pcs/pz |
|----------|-------|----|-----|--------|
| 47745-07 | 55    | 48 | 90  | 20     |

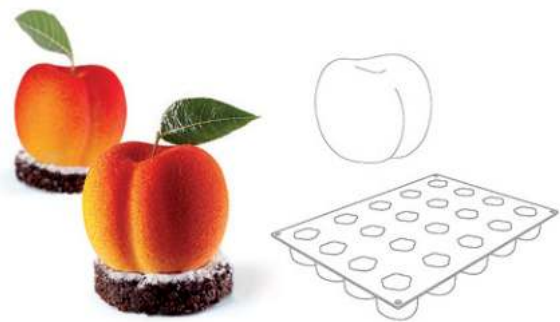

**Peach/Cherry**

**Pesca/Ciliegia**

| art.     | dim. mm. | ml. | pcs/pz |
|----------|----------|-----|--------|
| 47745-08 | 58x53x46 | 90  | 20     |

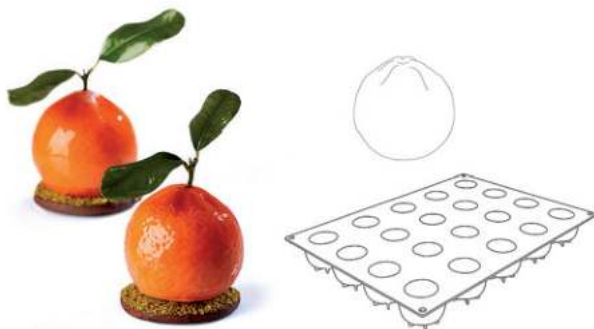

**Tangerine**

**Mandarino**

| art.     | Ø mm. | h. | ml. | pcs/pz |
|----------|-------|----|-----|--------|
| 47745-09 | 57    | 50 | 90  | 20     |

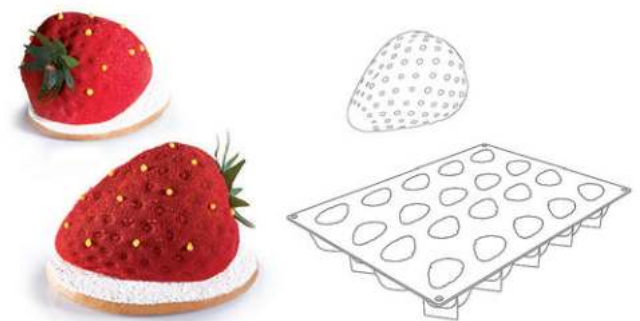

**Strawberry**

**Fragola**

| art.     | dim. mm. | ml. | pcs/pz |
|----------|----------|-----|--------|
| 47745-10 | 71x54x46 | 90  | 20     |

SILICONE MOLDS CM 60X40 - CM 40X30  
STAMPI SILICONE CM 60X40 - CM 40X30



**Quenelle 60x40**

| art.     | dim. mm. | ml. | pcs/pz |
|----------|----------|-----|--------|
| 47746-01 | 66x33x30 | 32  | 49     |

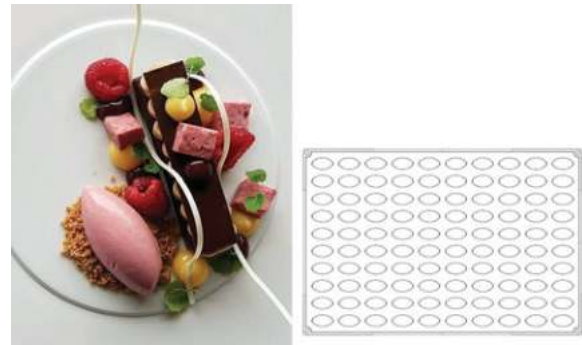

**Mini quenelle 60x40**

| art.     | dim. mm. | ml. | pcs/pz |
|----------|----------|-----|--------|
| 47746-02 | 42x20x20 | 8   | 100    |

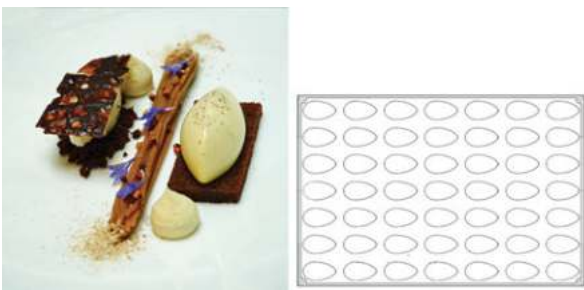

**Quenelle 60x40**

| art.     | dim. mm. | ml. | pcs/pz |
|----------|----------|-----|--------|
| 47746-03 | 66x35x26 | 34  | 49     |

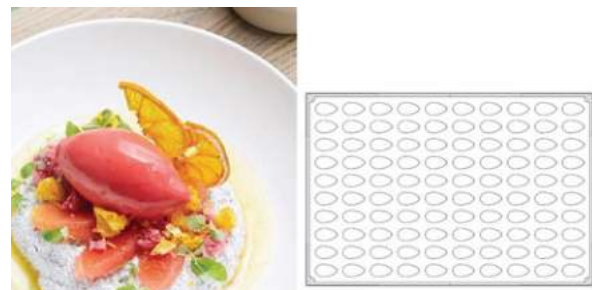

**Mini quenelle 60x40**

| art.     | dim. mm. | ml. | pcs/pz |
|----------|----------|-----|--------|
| 47746-04 | 42x22x17 | 9   | 100    |



**Sphere 40x30**

| art.     | Ø mm. | ml. | pcs/pz |
|----------|-------|-----|--------|
| 47745-02 | 20    | 4   | 48     |



**Sphere 40x30**

| art.     | Ø mm. | ml. | pcs/pz |
|----------|-------|-----|--------|
| 47745-03 | 30    | 14  | 30     |

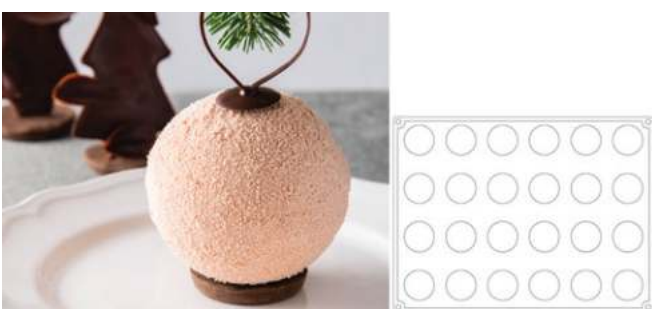

**Sphere 40x30**

| art.     | Ø mm. | ml. | pcs/pz |
|----------|-------|-----|--------|
| 47745-04 | 40    | 33  | 24     |

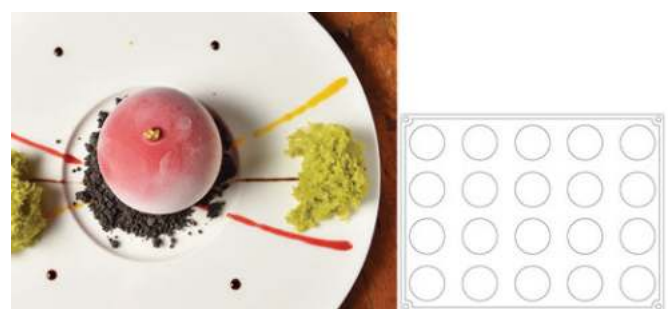

**Sphere 40x30**

| art.     | Ø mm. | ml. | pcs/pz |
|----------|-------|-----|--------|
| 47745-05 | 50    | 65  | 20     |



**100% PLATINUM SILICONE CAKE MOLDS, CM 17,5X30 - GN 1/3**  
STAMPI IN SILICONE PLATINICO 100%, CM 17,5X30 - GN 1/3



Suitable for freezing and baking (resistance from **-40°C up to +280°C**). For a correct use, put the moulds on grills or perforated trays, in order to improve the heat diffusion during baking. High non-stick properties to let a perfect demoulding of the product. Can be washed by hand or in dishwasher. Manufactured in conformity with international regulations concerning food contact: D.M. no. 104 of 21/03/1973 (Italian law) - Arrêté du 25/11/1992 (French law) - BGVV (German law) - FDA (USA law).

Adatti per la surgelazione e la cottura (resistono da **-40°C a +280°C**). Per un utilizzo ottimale, posizionare gli stampi su griglie o teglie forate per favorire la diffusione del calore durante la cottura. Elevata antiaderenza per consentire una perfetta sformatura del prodotto. Lavabili a mano e in lavastoviglie. Conforme alle norme internazionali che regolano l'utilizzo di materiali destinati al contatto con sostanze alimentari: D.M. n. 104 del 21/03/1973 (legislazione italiana) - Arrêté du 25/11/1992 (legislazione francese) - BGVV (legislazione tedesca) - FDA (legislazione statunitense).



**Big baba**  
Babà grande

| art.     | Ø mm. | h. | ml. | pcs/pz |
|----------|-------|----|-----|--------|
| 47742-02 | 55    | 60 | 97  | 8      |



**Medium baba**  
Babà medio

| art.     | Ø mm. | h. | ml. | pcs/pz |
|----------|-------|----|-----|--------|
| 47742-30 | 45    | 48 | 51  | 11     |



**Small baba**  
Babà piccolo

| art.     | Ø mm. | h. | ml. | pcs/pz |
|----------|-------|----|-----|--------|
| 47742-31 | 35    | 38 | 25  | 15     |



**Bavarian**  
Bavarese

| art.     | Ø mm. | h. | ml. | pcs/pz |
|----------|-------|----|-----|--------|
| 47742-41 | 57    | 57 | 110 | 8      |



**Fluted cake**  
Briochette cannellata

| art.     | Ø mm. | h. | ml. | pcs/pz |
|----------|-------|----|-----|--------|
| 47742-12 | 79    | 30 | 109 | 6      |



**Fluted cake**  
Briochette cannellata

| art.     | Ø mm. | h. | ml. | pcs/pz |
|----------|-------|----|-----|--------|
| 47742-27 | 79    | 37 | 100 | 6      |



**Cake**  
Cake

| art.     | dim. mm. | ml. | pcs/pz |
|----------|----------|-----|--------|
| 47742-56 | 80x30x30 | 62  | 9      |



**Cannelle**  
Cannelle

| art.     | Ø mm. | h. | ml. | pcs/pz |
|----------|-------|----|-----|--------|
| 47742-51 | 56    | 50 | 70  | 8      |



**Cylinder**  
Cilindro

| art.     | Ø mm. | h. | ml. | pcs/pz |
|----------|-------|----|-----|--------|
| 47742-17 | 60    | 35 | 89  | 8      |





**Heart**

Cuore

| art.     | dim. mm. | ml. | pcs/pz |
|----------|----------|-----|--------|
| 47742-25 | 65x60x35 | 97  | 8      |



**Biscuit disc**

Disco biscuit

| art.     | Ø mm. | h. | ml. | pcs/pz |
|----------|-------|----|-----|--------|
| 47742-23 | 103   | 20 | 160 | 3      |



**Florentine**

Florentine

| art.     | Ø mm. | h. | ml. | pcs/pz |
|----------|-------|----|-----|--------|
| 47742-19 | 60    | 12 | 27  | 8      |



**Madeleine**

Madeleine

| art.     | dim. mm.   | ml. | pcs/pz |
|----------|------------|-----|--------|
| 47742-21 | 68x45x18   | 30  | 9      |
| 47742-37 | 42x30x11,5 | 8   | 20     |



**Mini cannelle**

Mini cannelle

| art.     | Ø mm. | h. | ml. | pcs/pz |
|----------|-------|----|-----|--------|
| 47742-42 | 35    | 35 | 24  | 18     |



**Mini financier**

Mini finanziere

| art.     | dim. mm. | ml. | pcs/pz |
|----------|----------|-----|--------|
| 47742-14 | 49x26x11 | 11  | 20     |



**Mini guglhupf**

Mini guglhupf

| art.     | Ø mm. | h. | ml. | pcs/pz |
|----------|-------|----|-----|--------|
| 47742-34 | 60    | 33 | 70  | 6      |



**Mini muffin**

Mini muffin

| art.     | Ø mm. | h. | ml. | pcs/pz |
|----------|-------|----|-----|--------|
| 47742-20 | 50    | 28 | 43  | 11     |



**Mini oval**

Mini ovale

| art.     | dim. mm. | ml. | pcs/pz |
|----------|----------|-----|--------|
| 47742-09 | 53x33x20 | 28  | 16     |



**Mini pyramid**

Mini piramide

| art.     | dim. mm. | ml. | pcs/pz |
|----------|----------|-----|--------|
| 47742-13 | 36x36x22 | 13  | 15     |



**Mini savarin**

Mini savarin

| art.     | Ø mm. | h. | ml. | pcs/pz |
|----------|-------|----|-----|--------|
| 47742-05 | 41    | 12 | 12  | 18     |



**Muffin**

Muffin

| art.     | Ø mm. | h. | ml. | pcs/pz |
|----------|-------|----|-----|--------|
| 47742-08 | 70    | 40 | 130 | 6      |



**Muffin**

Muffin

| art.     | Ø mm. | h. | ml. | pcs/pz |
|----------|-------|----|-----|--------|
| 47742-33 | 80    | 35 | 110 | 5      |







**Petit four**  
Petit four

| art.     | Ø mm. | h. | ml. | pcs/pz |
|----------|-------|----|-----|--------|
| 47742-24 | 40    | 20 | 22  | 15     |



**Pyramid**  
Piramide

| art.     | dim. mm. | ml. | pcs/pz |
|----------|----------|-----|--------|
| 47742-07 | 71x71x40 | 92  | 6      |



**Pomponette**  
Pomponette

| art.     | Ø mm. | h. | ml. | pcs/pz |
|----------|-------|----|-----|--------|
| 47742-06 | 34    | 16 | 13  | 24     |



**Savarin**  
Savarin

| art.     | Ø mm. | h. | ml. | pcs/pz |
|----------|-------|----|-----|--------|
| 47742-15 | 72    | 23 | 67  | 6      |



**Savarin**  
Savarin

| art.     | Ø mm. | h. | ml. | pcs/pz |
|----------|-------|----|-----|--------|
| 47742-10 | 65    | 21 | 49  | 8      |



**Half sphere**  
Semisfera

| art.     | Ø mm. | h. | ml. | pcs/pz |
|----------|-------|----|-----|--------|
| 47742-04 | 30    | 17 | 8,5 | 24     |



**Half sphere**  
Semisfera

| art.     | Ø mm. | h. | ml. | pcs/pz |
|----------|-------|----|-----|--------|
| 47742-03 | 40    | 20 | 17  | 15     |



**Half sphere**  
Semisfera

| art.     | Ø mm. | h. | ml. | pcs/pz |
|----------|-------|----|-----|--------|
| 47742-48 | 50    | 23 | 33  | 15     |



**Half sphere**  
Semisfera

| art.     | Ø mm. | h. | ml. | pcs/pz |
|----------|-------|----|-----|--------|
| 47742-47 | 60    | 30 | 57  | 8      |



**Half sphere**  
Semisfera

| art.     | Ø mm. | h. | ml. | pcs/pz |
|----------|-------|----|-----|--------|
| 47742-01 | 70    | 35 | 89  | 6      |



**Half sphere**  
Semisfera

| art.     | Ø mm. | h. | ml. | pcs/pz |
|----------|-------|----|-----|--------|
| 47742-29 | 80    | 40 | 134 | 5      |



**Tartlet**  
Tartelletta

| art.     | Ø mm. | h. | ml. | pcs/pz |
|----------|-------|----|-----|--------|
| 47742-16 | 50    | 15 | 20  | 15     |



**Cakes**  
Tortine

| art.     | Ø mm. | h. | ml. | pcs/pz |
|----------|-------|----|-----|--------|
| 47742-61 | 80    | 18 | 85  | 6      |



**Round cake tin**  
Tortiera tonda

| art.     | Ø mm. | h. | ml.  |
|----------|-------|----|------|
| 47765-24 | 240   | 42 | 1850 |
| 47765-26 | 260   | 45 | 2250 |
| 47765-28 | 280   | 45 | 2600 |



**Fluted round cake tin**  
Tortiera tonda cannellata

| art.     | Ø mm. | h. | ml.  |
|----------|-------|----|------|
| 47766-26 | 260   | 30 | 1350 |
| 47766-28 | 280   | 30 | 1600 |
| 47766-30 | 300   | 30 | 1850 |



**Tart tin**  
Crostatina

| art.     | Ø mm. | h. | ml.  |
|----------|-------|----|------|
| 47771-28 | 280   | 30 | 1700 |



**Heart cake tin**  
Tortiera cuore

| art.     | dim. mm.   | ml.  |
|----------|------------|------|
| 47770-21 | 220x218x35 | 1150 |



**Plumcake**  
Plumcake

| art.     | dim. mm.   | ml.  |
|----------|------------|------|
| 47773-24 | 240x105x65 | 1385 |
| 47773-28 | 280x105x65 | 1660 |



**Rectangular cake pan**  
Tortiera rettangolare

| art.     | dim. mm.   | ml.  |
|----------|------------|------|
| 47769-28 | 280x240x40 | 2670 |



**Drainer**  
Sgocciolatore

| art.     | dim. cm.   |
|----------|------------|
| 47742-00 | 30x30x17,5 |

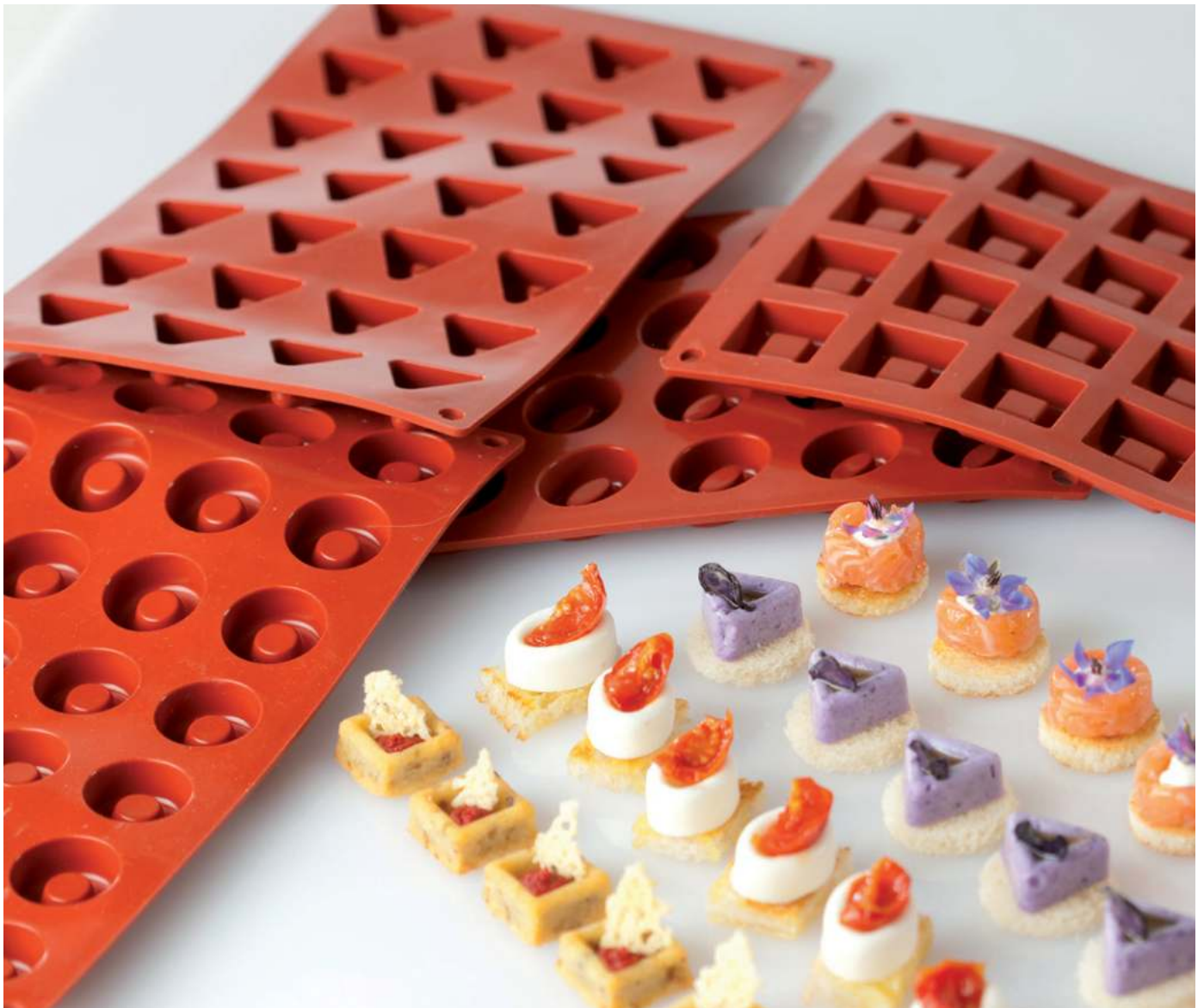
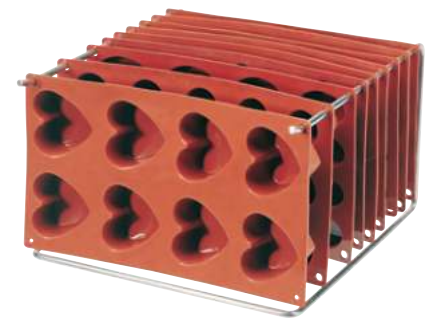



# FLEXIPAN



PASTRY  
PASTICCERIA



The Sasa Demarle Group is the only company in the world to formulate and produce its own food silicone, specially designed for the bakery and pastry industry. The use of this silicone allows an optimal heat distribution, which offers an even baking and colour, as well as perfect non-stick properties for an easy and perfect demoulding. The Flexipan moulds offer great performances with high lifetime expectancy: from 3,000 to 5,000+ baking cycles, depending on the conditions of use. Can be used for cooking and freezing (from -40°C to +240°C), for sweet and/or savory recipes. Can be easily cleaned with water.

Il gruppo Sasa Demarle è l'unica azienda al mondo a formulare e produrre il proprio silicone alimentare, appositamente progettato per l'industria della panificazione e della pasticceria. L'uso di questo silicone consente una distribuzione ottimale del calore, offrendo una cottura e un colore uniformi, nonché proprietà antiaderenti perfette per una facile e perfetta sfornatura. Gli stampi Flexipan offrono grandi prestazioni con un'elevata aspettativa di durata: da 3.000 a 5.000+ cicli di cottura, a seconda delle condizioni di utilizzo. Può essere utilizzato per cucinare e congelare (da -40°C a +240°C), per ricette dolci e/o salate. Si pulisce facilmente con acqua.



**Annapurna**

Pcs/pz 5 - ml. 370

art. mm.

47740137 495x40x33

With s/s frame. – Con supporto inox.



**Bavarois**

Pcs/pz 18 - ml. 100

art. Ø mm. h.

47740105 78 35



**Caterpillar**

Pcs/pz 5 - ml. 450

art. mm.

47740138 495x40x36

With s/s frame. – Con supporto inox.



**Champagne biscuits**

Pcs/pz 45 - ml. 20

art. mm.

47740-29 109x24x10



**Charlotte**

Pcs/pz 24 - ml. 60

art. Ø mm. h.

47740-80 62 35



**Charlotte**

Pcs/pz 18 - ml. 100

art. Ø mm. h.

47740-23 78 40



**Chocolate bars**

Pcs/pz 18 - ml. 100

art. mm.

47740128 78x58x40

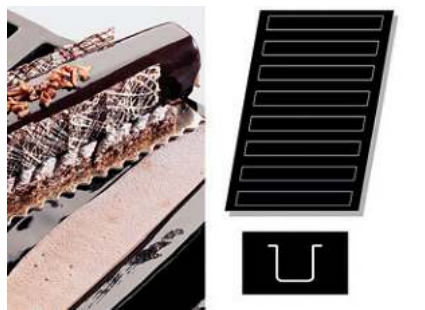

**Christmas log**

Pcs/pz 8 - ml. 450

art. mm.

47740-28 339x40x39

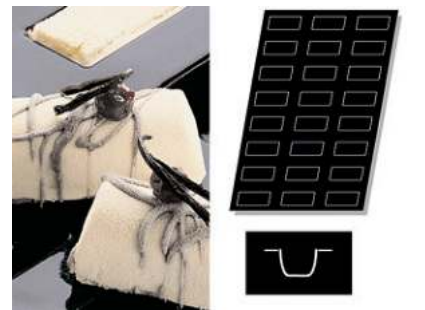

**Christmas log**

Pcs/pz 24 - ml. 80

art. mm.

47740-26 95x40x30

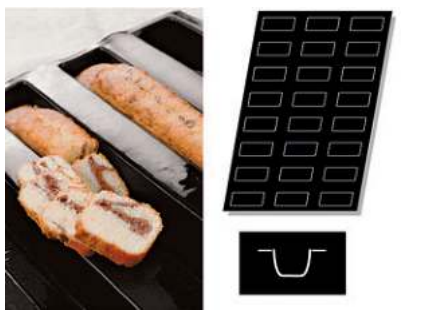

**Christmas log**

Pcs/pz 24 - ml. 115

art. mm.

47740-27 122x42x32



**Christmas log insert**

Pcs/pz 5 - ml. 700

art. mm.

47740-93 495x40x39

With s/s frame. – Con supporto inox.



**Christmas tree**

Pcs/pz 20 - ml. 100

art. mm.

47740119 90x85x30



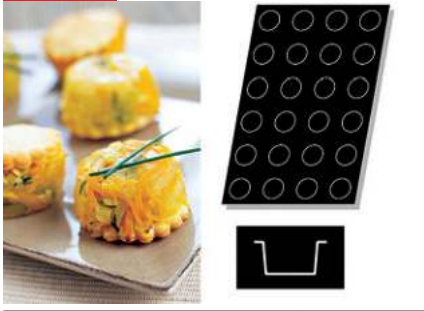

**Cylinders**

Pcs/pz 24 - ml. 65

| art.     | Ø mm. | h. |
|----------|-------|----|
| 47740-52 | 63/55 | 25 |
| 47740-06 | 63/55 | 35 |



**Cylinders**

Pcs/pz 15 - ml. 220

| art.     | Ø mm. | h. |
|----------|-------|----|
| 47740-69 | 82    | 50 |
| 47740-70 | 91    | 35 |



**Cone insert**

Pcs/pz 40 - ml. 24

| art.     | Ø mm. | h. |
|----------|-------|----|
| 47740102 | 50    | 40 |



**Cones**

Pcs/pz 20 - ml. 80

| art.     | Ø mm. | h. |
|----------|-------|----|
| 47740103 | 70    | 60 |



**Cookies**

Pcs/pz 40 - ml. 30

| art.     | Ø mm. | h. |
|----------|-------|----|
| 47740-18 | 59/48 | 13 |
| 47740-60 | 78    | 10 |



**Cookies**

Pcs/pz 12 - ml. 245

| art.     | Ø mm. | h. |
|----------|-------|----|
| 47740-74 | 100   | 35 |
| 47740-75 | 105   | 40 |



**Eggs**

Pcs/pz 25 - ml. 95

| art.     | mm.      |
|----------|----------|
| 47740135 | 94x60x31 |

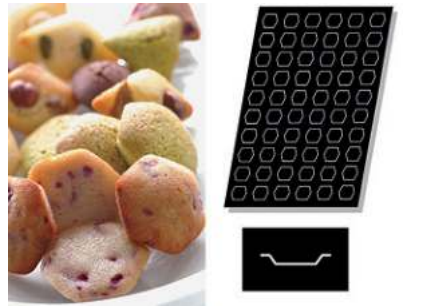

**Exagon**

Pcs/pz 60 - ml. 12

| art.     | mm.      |
|----------|----------|
| 47740-83 | 45x40x12 |

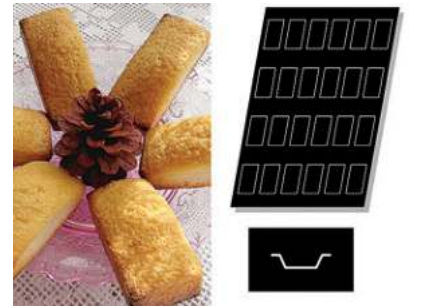

**Financiers**

Pcs/pz 24 - ml. 45

| art.     | mm.      |
|----------|----------|
| 47740-10 | 86x46x14 |

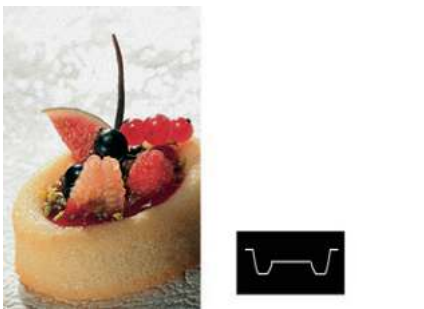

**Flan bases**

Pcs/pz 24 - ml. 70

| art.     | Ø mm. | h. |
|----------|-------|----|
| 47740-43 | 80    | 20 |



**Fluted brioche**

Pcs/pz 24 - ml. 60

| art.     | mm.      |
|----------|----------|
| 47740-57 | 62x49x26 |

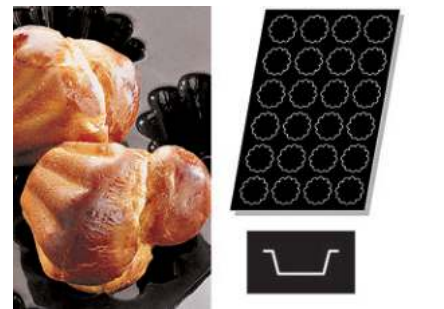

**Fluted brioche**

Pcs/pz 24 - ml. 60

| art.     | Ø mm. | h. |
|----------|-------|----|
| 47740-58 | 68    | 25 |
| 47740-59 | 78    | 30 |
| 47740-16 | 81    | 37 |



**Fluted cakes**

Pcs/pz 16 - ml. 105

art. mm.

47740-95 110x60x25



**Fluted ingots**

Pcs/pz 24 - ml. 90

art. mm.

47740127 106x46x25



**Fluted tartlets**

Pcs/pz 24 - ml. 70

art. mm.

47740132 78x78x20

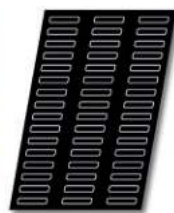

**Half cylinder**

Pcs/pz 48 - ml. 20

art. mm.

47740125 85x17x15



**Half sphere**

Pcs/pz 48 - ml. 20

art. Ø mm. h.  
47740-02 42 21



**Half sphere**

Pcs/pz 24 - ml. 125

art. Ø mm. h.  
47740-38 80 40



**Half sphere**

Pcs/pz 28 - ml. 150

art. Ø mm. h.

47740-37 58 31



**Half sphere**

Pcs/pz 24 - ml. 105

art. Ø mm. h.

47740-03 70 40



**Hearts**

Pcs/pz 81 - ml. 200

art. mm.

47740-89 75x65x35



**Hearts**

Pcs/pz 20 - ml. 90

art. mm.

47740-41 66x62x35



**Hexagons**

Pcs/pz 20 - ml. 90

art. Ø mm. h.

47740130 80 25



**Hollow ingot**

Pcs/pz 24 - ml. 70

art. mm.

47740123 100x40x25

47740124 120x40x25





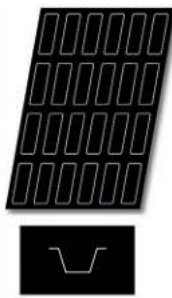

**Ingot**

Pcs/pz 24 - ml. 100

art. mm.

47740122 120x40x25

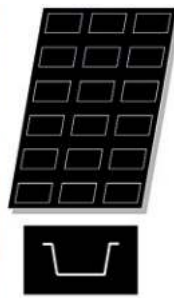

**Ingot**

Pcs/pz 18 - ml. 139

art. mm.

47740-94 102x58x30



**Interlacing hearts**

Pcs/pz 8 - ml. 200

art. mm.

47740101 120x113x35



**Landscapes**

Pcs/pz 27 - ml. 80

art. Ø mm. h.

47740144 75 24



**Little cushion**

Pcs/pz 24 - ml. 70

art. mm.

47740-77 71x57x23



**Madeleines**

Pcs/pz 40 - ml. 35

art. mm.

47740-17 78x47x19



**Medallions**

Pcs/pz 54 - ml. 14

art. Ø mm. h.

47740-50 38 10

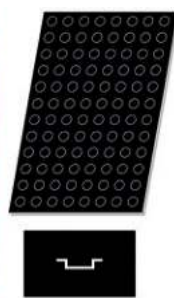

**Medallions**

Pcs/pz 96 - ml. 5

art. Ø mm. h.

47740-97 28 8



**Mini Charlotte**

Pcs/pz 60 - ml. 9

art. Ø mm. h.

47740-82 35 15



**Mini chenilles**

Pcs/pz 27 - ml. 90

art. mm.

47740143 102x40x36



**Mini drops**

Pcs/pz 56 - ml. 18

art. mm.

47740133 52x32x20



**Mini écrins**

Pcs/pz 24 - ml. 65

art. mm.

47740142 50x50x29

**PASTRY PASTICCERIA  
FLEXIPAN SILICONE 60X40 CM**

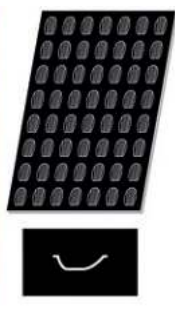

**Mini Madeleines**

Pcs/pz 56 - ml. 15

art. mm.

47740106 52x33x15



**Mini St Honoré crown**

Pcs/pz 18 - ml. 70

art. Ø mm. h.

47740131 80 20

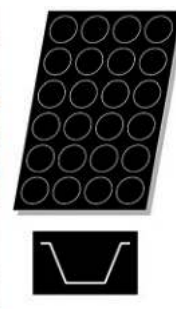

**Muffins**

Pcs/pz 24 - ml. 125

art. Ø mm. h.

47740-19 73 40

47740-68 79 36



**Optagon**

Pcs/pz 40 - ml. 28

art. mm.

47740-34 43x40x26



**Oval savarins**

Pcs/pz 12 - ml. 230

art. mm.

47740-81 100x80x45



**Oval savarins**

Pcs/pz 30 - ml. 48

art. mm.

47740111 70x50x22



**Oval savarins**

Pcs/pz 24 - ml. 70

art. mm.

47740-44 80x60x25

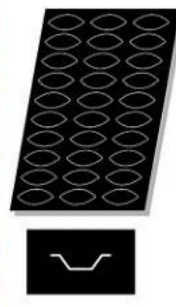

**Oval tartlets**

Pcs/pz 30 - ml. 35

art. mm.

47740-32 106x45x15



**Ovals**

Pcs/pz 24 - ml. 80

art. mm.

47740-49 96x45x28



**Ovals**

Pcs/pz 30 - ml. 55

art. mm.

47740-46 70x50x25

47740-47 70x50x30



**Ovals**

Pcs/pz 20 - ml. 100

art. mm.

47740-48 85x60x30

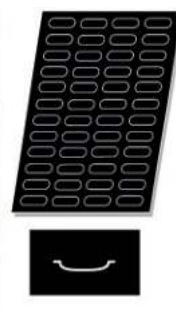

**Ovals**

Pcs/pz 48 - ml. 15

art. mm.

47740-92 70x30x10





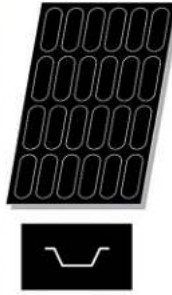

**Ovals**

Pcs/pz 24 - ml. 80

art. mm.

47740-55 130x48x18



**Pomponnettes**

Pcs/pz 96 - ml. 14

art. Ø mm. h.

47740-04 36 17



**Puddings**

Pcs/pz 15 - ml. 128

art. Ø mm. h.

47740104 65 55



**Pyramids**

Pcs/pz 24 - ml. 90

art. mm.

47740-13 71x71x41

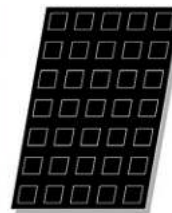

**Pyramids flat bottom**

Pcs/pz 35 - ml. 50

art. mm.

47740-39 50x50x35



**Quiches**

Pcs/pz 15 - ml. 135

art. Ø mm. h.

47740-85 96 25



**Quiches**

Pcs/pz 24 - ml. 65

art. Ø mm. h.

47740-30 77 20



**Quiches**

Pcs/pz 42 - ml. 30

art. mm.

47740-45 60x40x25

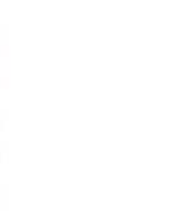

**Quiches**

Pcs/pz 15 - ml. 140

art. Ø mm. h.

47740-62 102 20



**Quiches**

Pcs/pz 6 - ml. 200

art. Ø mm. h.

47740-64 147 12

47740-65 150 15

47740-66 166 12



**Quiches**

Pcs/pz 6 - ml. 360

art. Ø mm. h.

47740-71 140 25

47740-72 150 24

47740-05 186 12

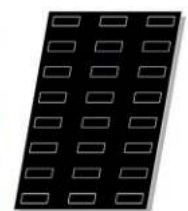

**Rectangular cakes**

Pcs/pz 24 - ml. 55

art. mm.

47740-25 80x30x30

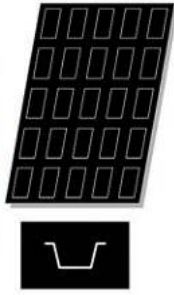

**Rectangular cakes**

Pcs/pz 25 - ml. 110

art. mm.

47740-24 89x46x25

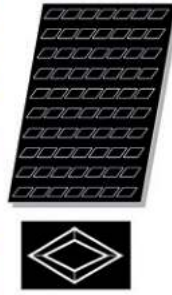

**Rhombus**

Pcs/pz 70 - ml. 9

art. mm.

47740-36 60x35x10



**Round**

Pcs/pz 11 - ml. 75

art. Ø mm. h.

47740-63 125 16



**Round brioche**

Pcs/pz 24 - ml. 65

art. Ø mm. h.

47740-56 79 15



**Savarin zaphire**

Pcs/pz 24 - ml. 80

art. mm.

47740114 70x70x32



**Savarins**

Pcs/pz 35 - ml. 50

art. Ø mm. h.

47740-20 66 20



**Savarins**

Pcs/pz 24 - ml. 65

art. Ø mm. h.

47740-15 70 23



**Scoop out**

Pcs/pz 24 - ml. 90

art. mm.

47740145 85x61x30

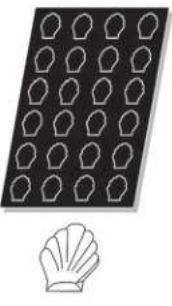

**Shells**

Pcs/pz 24 - ml. 70

art. mm.

47740-79 80x75x20

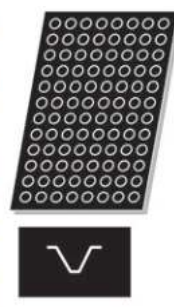

**Small cones**

Pcs/pz 96 - ml. 6

art. Ø mm. h.

47740-99 30 20

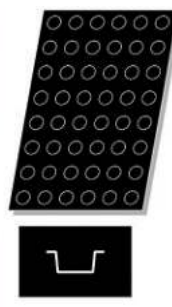

**Small cylinders**

Pcs/pz 48 - ml. 25

art. Ø mm. h.

47740-51 40 20



**Small financiers**

Pcs/pz 84 - ml. 10

art. mm.

47740-09 50x26x11





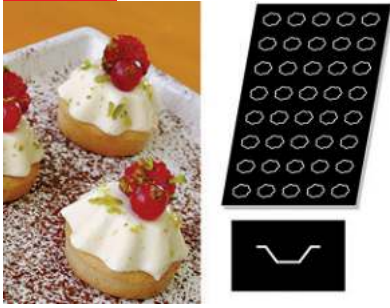

**Small fluted tartlet**

Pcs/pz 40 - ml. 11

art. mm.

47740100 46x38x15

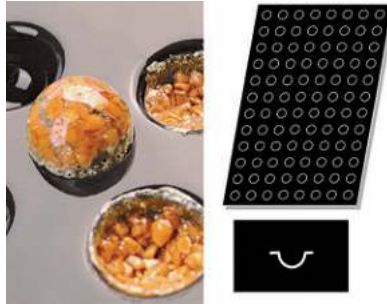

**Small half sphere**

Pcs/pz 96 - ml. 6

art. Ø mm. h.

47740-87 26 16

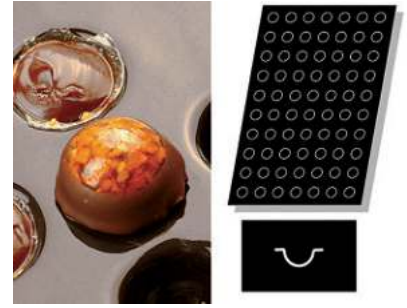

**Small half sphere**

Pcs/pz 70 - ml. 10

art. Ø mm. h.

47740-01 29 18

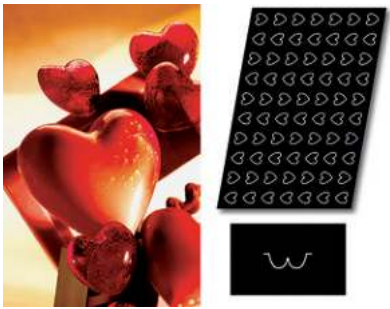

**Small hearts**

Pcs/pz 70 - ml. 15

art. mm.

47740115 41x38x16



**Small muffins**

Pcs/pz 40 - ml. 45

art. Ø mm. h.

47740-67 51 29

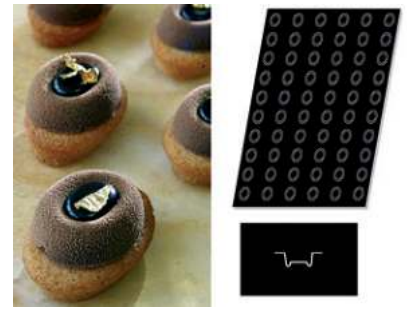

**Small oval savarins**

Pcs/pz 60 - ml. 9

art. mm.

47740-98 40x30x12



**Small oval tartlets**

Pcs/pz 48 - ml. 10

art. mm.

47740-31 66x27x11



**Small ovals**

Pcs/pz 50 - ml. 20

art. mm.

47740-11 51x31x20

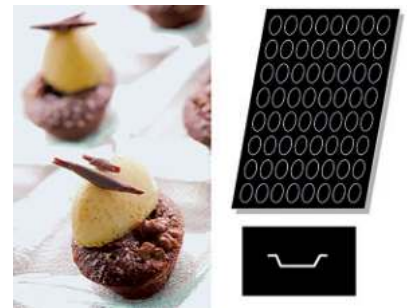

**Small ovals flat bottom**

Pcs/pz 64 - ml. 18

art. mm.

47740-91 57x35x12

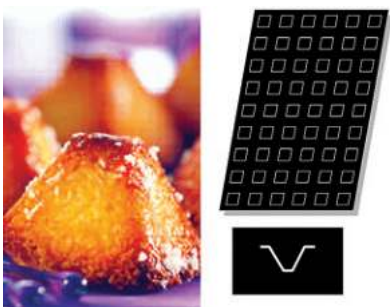

**Small pyramids**

Pcs/pz 54 - ml. 15

art. mm.

47740-12 35x35x23

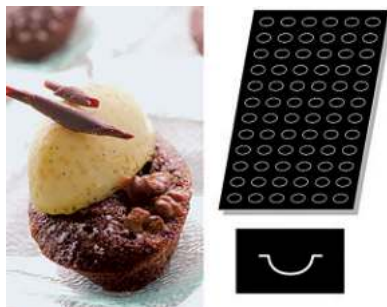

**Small quenelles**

Pcs/pz 72 - ml. 56

art. mm.

47740-90 42x26x20

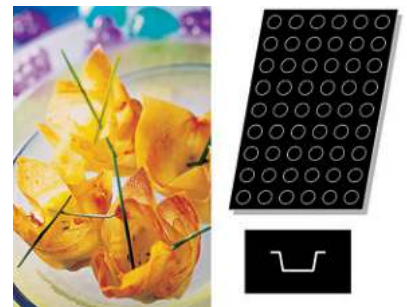

**Small quiches**

Pcs/pz 54 - ml. 22

art. Ø mm. h.

47740-33 40 20



**Small quiches**

Pcs/pz 60 - ml. 13

art.      Ø mm.    h.  
47740-07    42      10



**Small quiches**

Pcs/pz 48 - ml. 20

art.      Ø mm.    h.  
47740-08    48      15



**Small quiches**

Pcs/pz 40 - ml. 35

art.      Ø mm.    h.  
47740-84    58      20



**Small Savarins**

Pcs/pz 60 - ml. 15

art.      mm.  
47740107    7x37x17



**Small savarins**

Pcs/pz 60 - ml. 10

art.      Ø mm.    h.  
47740-14    41      12



**Small squares**

Pcs/pz 60 - ml. 18

art.      mm.  
47740116    37x37x17



**Small squares**

Pcs/pz 60 - ml. 20

art.      mm.  
47740109    45x45x12



**Small upside-down half sphere**

Pcs/pz 45 - ml. 6

art.      Ø mm.    h.  
47740-86    26      16



**Square Savarins**

Pcs/pz 35 - ml. 45

art.      mm.  
47740108    56x56x24



**Square Savarins**

Pcs/pz 24 - ml. 100

art.      mm.  
47740-96    70x70x30



**Squares**

Pcs/pz 35 - ml. 60

art.      mm.  
47740117    56x56x24



**Squares**

Pcs/pz 40 - ml. 40

art.      mm.  
47740110    60x60x15







**Stars**

Pcs/pz 24 - ml. 35

art. mm.

47740-88 80x65x15

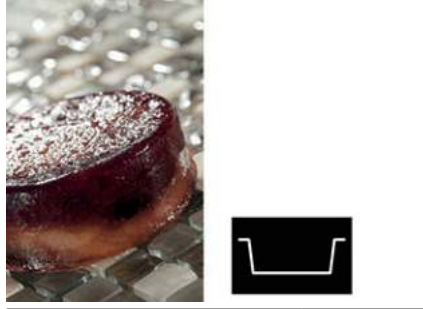

**Tarte tatin**

Pcs/pz 15 - ml. 135

art. Ø mm. h.

47740-73 82 30

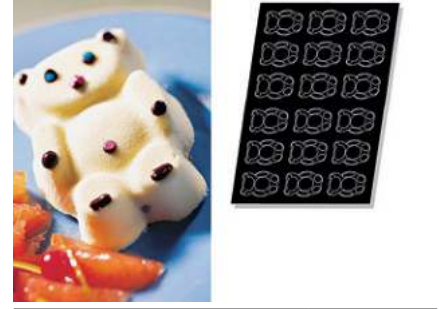

**Teddy bear**

Pcs/pz 18 - ml. 80

art. mm.

47740-53 90x55x20



**Triangles**

Pcs/pz 80 - ml. 7

art. mm.

47740-35 48x41x10

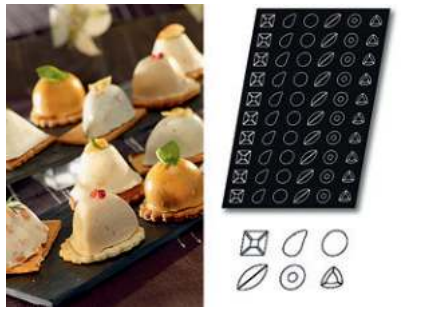

**Variou petits-fours**

Pcs/pz 60

art. h. mm.

47740134 22



**Zaphire**

Pcs/pz 54 - ml. 17

art. mm.

47740112 40x40x24



**Zaphire**

Pcs/pz 24 - ml. 75

art. mm.

47740113 70x70x35



**Calisss**

Pcs/pz 20 - ml. 118

art. mm.

47743-03 180x90x50

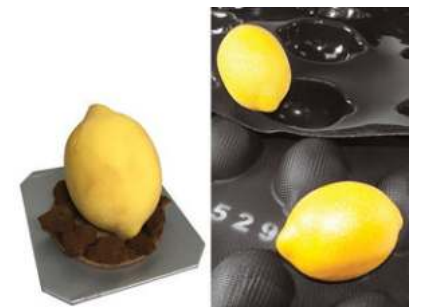

**Lemon**

Pcs/pz 20 - ml. 73

art. mm.

47743-05 85x65x34



**Triangles**

Pcs/pz 24 - ml. 80

art. mm.

47743-10 70x95x25



**Donuts**

Pcs/pz 8

art. Ø mm. h.

47743-13 88 30



**Donuts**

Pcs/pz 8

art. mm.

47743-13 88 30



**Insert ring**

Pcs/pz 24

| art.     | Ø mm. | h. |
|----------|-------|----|
| 47743-15 | 61    | 9  |



**Ring 3D**

Pcs/pz 24

| art.     | Ø mm. | h. |
|----------|-------|----|
| 47743-16 | 76    | 25 |



**Pearls**

Pcs/pz 15 - ml. 100

| art.     | Ø mm. | h. |
|----------|-------|----|
| 47743-65 | 73    | 40 |



**FLEXIPAN GN 1/1**



**Small half sphere**

Pcs/pz 5 - ml. 63

| art.     | Ø mm. | h. |
|----------|-------|----|
| 47741-76 | 23    | 11 |

**FLEXIPAN CM 40X30**



**Small hearts**

Pcs/pz 30 - ml. 15

| art.     | mm.      |
|----------|----------|
| 47741-78 | 52x49x10 |

**FLEXIPAN CM 40X30**



**Half sphere flat**

Pcs/pz 48 - ml. 10

| art.     | Ø mm. | h. |
|----------|-------|----|
| 47741-77 | 30    | 13 |

**FLEXIPAN CM 40X30**



**Twist**

Pcs/pz 48

| art.     | Ø mm. | h. |
|----------|-------|----|
| 47741-00 | 32    | 20 |

**FLEXIPAN CM 40X30**



**Stars**

Pcs/pz 48

| art.     | Ø mm. | h. |
|----------|-------|----|
| 47741-01 | 32    | 13 |

**FLEXIPAN CM 40X30**



**Insert fingers**

Pcs/pz 18

| art.     | mm.    |
|----------|--------|
| 47741-02 | 120x11 |

**FLEXIPAN CM 40X30**



**Sphere 3D**

Pcs/pz 8

| art.     | Ø mm. | h. |
|----------|-------|----|
| 47741-05 | 65    | 50 |

**FLEXIPAN CM 40X30**



**Cylinder**

Pcs/pz 24 - ml. 148

| art.     | Ø mm. | h. |
|----------|-------|----|
| 47744-30 | 70    | 40 |

**FLEXIPAT CM 60x40**



**Cube**

Pcs/pz 96 - ml. 17

| art.     | mm.      |
|----------|----------|
| 47744-32 | 30x30x20 |

**FLEXIPAT CM 60x40**





**Kougloff**

Pcs/pz 24 - ml. 150

art.      Ø mm.    h.  
47744-31    80      54

**FLEXIPAT CM 60x40**

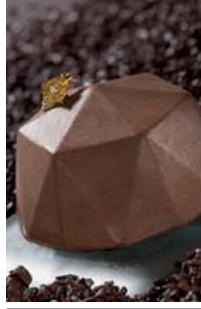

**Diamond**

Pcs/pz 24 - ml. 100

art.      Ø mm.    h.  
47744-34    79      40

**FLEXIPAT CM 60x40**



**Waffels**

Pcs/pz 8 - ml. 100

art.      mm.  
47741-38    80x127x15

**FLEXIPAT CM 40X30**



**Fingers**

Pcs/pz 24 - ml. 54

art.      mm.  
47741-37    129x28x15

**FLEXIPAT CM 40X30**



**Buche**

ml. 140

art.      mm.  
47744-80    280x85x70



**Half sphere**

ml. 1600

art.      Ø mm.    h.  
47744-81    180      90



**Flexiform desserts**

ml. 222

art.      mm.  
47744-58    253x253x45



**Flexiform desserts**

ml. 980

art.      mm.  
47744-59    600x400x50



**Flexiform desserts**

art.      mm.  
47744-48    480x280x13  
47744-60    555x360x10  
47744-62    555x360x20



**Tapis Rosette**

art.      Ø mm.  
47744-10    240



**Tapis Venetian cane**

art.      mm.  
47744-19    555x360



**Tapis Labyrinth**

art. mm.  
47744-21 600x400



**Tapis Bubbles**

art. mm.  
47744-36 600x400



**Tapis Mikado**

art. mm.  
47744-37 600x400



**Tapis Snowflake**

art. Ø mm.  
47744-63 240



**Tapis Buche2**

art. mm.  
47744-70 275x185



**Tapis Buche1**

art. mm.  
47744-71 275x185

**FLEXIPAN AIR CM 60X40**

PUFFS - BIGNE' - WINDBEUTEL - CHOUX - BOLLOS/BREADS - PANE - BROT - PAIN - PAN



Flexible pans made of silicone and glass fiber fabric and bi-component, designed for bread-making and bakery products, especially for cream puffs dough. The pre-formed shapes make easy obtaining perfect, regular and same size products. Neither greasing the sheet nor spiking the dough is required before baking. The non-stick property of the material allows an easy and perfect extraction. They have a well-ventilated texture that ensures proper heat circulation, to obtain a crusty finished product with excellent color. Non-stick FLEXIPAN® AIR sheets are very durable, lasting up to 1500 cycles without any risk of sticking. For baking up to +240°, as well as for freezing at -40°, and are also designed to hold frozen dough.

Stampi flessibili realizzati in silicone e tessuto in fibra di vetro e bicomponente, ideali per la panificazione e prodotti dolci da forno, in particolare per la pasta di bigné. Grazie alle impronte preformate, preparare prodotti uguali e regolari diventa facile. Non è più indispensabile spennellare con tuorlo o forare la pasta. Grazie alle sue proprietà antiaderenti l'estrazione è impeccabile. Hanno una texture ben ventilata che garantisce una corretta circolazione del calore, per ottenere un prodotto finito croccante e dal colore eccellente. Gli stampi FLEXIPAN® AIR sono molto resistenti, durano fino a 1500 cicli senza alcun rischio che il prodotto si attacchi. Per cotture fino a +240°, come pure per congelare a -40°, e sono progettati anche per contenere impasti congelati.



**Paris-Brest**

Pcs/pz 24 - ml. 10

art. Ø mm. h.  
41760-27 80 15



**Oval choux**

Pcs/pz 25 - ml. 56

art. mm.  
41760-26 90x60x15



**Baby choux**

Pcs/pz 59 - ml. 4

art. Ø mm. h.  
41760-22 30 5





**Big choux**

Pcs/pz 28 - ml. 48

| art.     | Ø mm. | h. |
|----------|-------|----|
| 41759-01 | 67    | 15 |



**Eclairs - Right handed. Per ambidestri**

Pcs/pz 18 - ml. 15

| art.     | mm.      |
|----------|----------|
| 41760-20 | 125x25x5 |



**Eclairs - Left handed. Per mancini.**

Pcs/pz 18 - ml. 15

| art.     | mm.      |
|----------|----------|
| 41760-21 | 125x25x5 |



**Round shapes/Rotondi**

Pcs/pz 28 - ml. 48

| art.     | Ø mm. | h. |
|----------|-------|----|
| 41759-01 | 67    | 15 |



**Round shapes/Rotondi**

Pcs/pz 15 - ml. 140

| art.     | Ø mm. | h. |
|----------|-------|----|
| 41759-05 | 102   | 20 |



**Round shapes/Rotondi**

Pcs/pz 11 - ml. 175

| art.     | Ø mm. | h. |
|----------|-------|----|
| 41759-09 | 125   | 16 |



**Oval shapes/Ovali**

Pcs/pz 24 - ml. 80

| art.     | mm.   | h. |
|----------|-------|----|
| 41760-02 | 95x40 | 30 |



**Oval shapes/Ovali**

Pcs/pz 18 - ml. 50

| art.     | mm.    | h. |
|----------|--------|----|
| 41760-05 | 155x41 | 25 |



**Oval shapes/Ovali**

Pcs/pz 12 - ml. 230

| art.     | mm.    | h. |
|----------|--------|----|
| 41760-06 | 169x64 | 30 |





**Oval shapes/Ovali**

Pcs/pz 8 - ml. 400

| art.     | mm.    | h. |
|----------|--------|----|
| 41760-08 | 259x64 | 30 |



**Oval shapes/Ovali**

Pcs/pz 6 - ml. 445

| art.     | mm.    | h. |
|----------|--------|----|
| 41760-09 | 299x60 | 30 |



**French loaves perforated sheet, silicone coated**

Teglia alluminio forato, siliconata

Pariserbrotblech, Silikon-beschichtet

Plaque perforée pain parisien, siliconée

Placa pan perforada, siliconada

| art.     | cm.   | pcs/pz |
|----------|-------|--------|
| 41758-53 | 53x32 | 4      |
| 41758-60 | 60x40 | 5      |
| 41758-65 | 65x43 | 6      |
| 41758-85 | 85x43 | 6      |



ABS

**Bread mould**

Stampo per pane

Brot-Ausstechforme

Découpoir à pain

Cortador para pan

| art.     | cm.   |
|----------|-------|
| 47041-01 | 14x10 |



ABS

**Bread mould**

Stampo per pane

Brot-Ausstechforme

Découpoir à pain

Cortador para pan

| art.     | cm.   |
|----------|-------|
| 47041-02 | 14x11 |



ABS

**Bread mould**

Stampo per pane

Brot-Ausstechforme

Découpoir à pain

Cortador para pan

| art.     | Ø cm. |
|----------|-------|
| 47041-03 | 12,5  |



ABS

**Bread mould**

Stampo per pane

Brot-Ausstechforme

Découpoir à pain

Cortador para pan

| art.     | cm.      |
|----------|----------|
| 47041-04 | 16,5x8,5 |



ABS

**Bread mould**

Stampo per pane

Brot-Ausstechforme

Découpoir à pain

Cortador para pan

| art.     | Ø cm. |
|----------|-------|
| 47041-05 | 12,5  |



ABS

**Bread mould**

Stampo per pane

Brot-Ausstechforme

Découpoir à pain

Cortador para pan

| art.     | Ø cm. |
|----------|-------|
| 47041-06 | 8     |



ABS

**Bread mould**

Stampo per pane

Brot-Ausstechforme

Découpoir à pain

Cortador para pan

| art.     | Ø cm. |
|----------|-------|
| 47041-07 | 8     |



ABS

**Bread mould**

Stampo per pane

Brot-Ausstechforme

Découpoir à pain

Cortador para pan

| art.     | Ø cm. |
|----------|-------|
| 47041-08 | 8     |



ABS

**Bread mould**

Stampo per pane

Brot-Ausstechforme

Découpoir à pain

Cortador para pan

| art.     | Ø cm. |
|----------|-------|
| 47041-15 | 8     |





**ABS**

**Kaiser bread marker**

Marcatore pane Kaiser  
Kaiserbrot Stempel  
Empreinte pain Kaiser  
Molde pan Kaiser

| art.     | Ø cm. | l. cm. |
|----------|-------|--------|
| 47040-00 | 6     | 20     |



**Bread brush**

Spazzola pane  
Brot-Bürste  
Brosse à pain  
Cepillo para pan

| art.     | l. cm. |
|----------|--------|
| 42614-04 | 24,5   |
| 42614-05 | 32,0   |
| 42614-06 | 41,0   |
| 42614-07 | 46,0   |



**SS**

**Disposable baker's blades**

Lame panettiere usa e getta  
Einweg-Bäcker-Klingen  
Incisette boulanger jetables  
Láminas del panadero desechables

| art.     | l. cm. | pcs/pz |
|----------|--------|--------|
| 48290-10 | 12     | 10     |



**PE**

**Bread basket**

Cesta pane  
Brot-Korb  
Corbeille à pain  
Cesta pan

| art.     | cm.      | lt. |
|----------|----------|-----|
| 44982-04 | 57x36x34 | 40  |
| 44982-06 | 66x45x35 | 60  |
| 44982-10 | 78x52x40 | 100 |



**PP**

**Bread proofing basket**

Cestino impasto  
Gärkorb  
Banneton  
Molde para pan

| art.     | Ø cm. | h.  | gr.  | col. |
|----------|-------|-----|------|------|
| 47042-19 | 19    | 7,5 | 500  | ●    |
| 47042-22 | 22    | 9,3 | 1000 | ●    |
| 47042-25 | 25    | 9,0 | 1500 | ●    |



**PP**

**Bread proofing basket**

Cestino impasto  
Gärkorb  
Banneton  
Molde para pan

| art.     | cm.       | gr.  | col. |
|----------|-----------|------|------|
| 47043-27 | 27x12x6,5 | 500  | ●    |
| 47043-35 | 35x13x7,2 | 1000 | ●    |
| 47043-42 | 42x14x7,5 | 1500 | ●    |





# ETHNIC CUISINE CUCINA ETNICA

ASIA FUSION



The images of the products in this chapter reflect the characteristics of the products in the warehouse. However, they have to be considered mainly for illustrative purposes only. Although we make every effort to display the products accurately, the products received may vary slightly from those images. In any case the changes are intended as improvements and do not alter the function, nor lessen the utility of the product.

Tutte le foto degli articoli presenti nel capitolo rispecchiano il più possibile le caratteristiche dei prodotti presenti in magazzino. Teniamo comunque a precisare che le immagini sono indicative ed i prodotti reali potrebbero differire nei colori e nelle dimensioni. Le variazioni sono in ogni caso migliorative e tali da non alterare la natura e la funzionalità del prodotto stesso.



**FINE MELAMINE SERIES THARA**



Withstands temperatures from -20°C to +70°C.

Termoresistenti da -20°C a +70°C.



**Rice bowl**

Coppa riso  
Reistasse  
Bol à riz  
Copa arroz

| art.     | Ø cm. | h. | lt. | col. |
|----------|-------|----|-----|------|
| 44463-11 | 11    | 7  | 0,3 | ●    |



**Tray**

Vassoio  
Platte  
Plateau  
Placa

| art.     | dim. cm.   | col. |
|----------|------------|------|
| 44464-23 | 23,5x7,5x2 | ●    |



**Tray**

Vassoio  
Platte  
Plateau  
Placa

| art.     | dim. cm.     | col. |
|----------|--------------|------|
| 44465-24 | 24,5x6,5x1,5 | ●    |



**Bowl**

Ciotola  
Schüssel  
Bol  
Bol Ensalada

| art.     | Ø cm. | h.  | col. |
|----------|-------|-----|------|
| 44452-31 | 31    | 8,5 | ○    |
| 44452B31 | 31    | 8,5 | ●    |



**Bowl**

Ciotola  
Schüssel  
Bol  
Bol Ensalada

| art.     | dim. cm.    | col. |
|----------|-------------|------|
| 44453-14 | 14,5x12x5,5 | ○    |
| 44453B14 | 14,5x12x5,5 | ●    |



**Bowl**

Ciotola  
Schüssel  
Bol  
Bol Ensalada

| art.     | Ø cm. | h. | col. |
|----------|-------|----|------|
| 44454-11 | 11,5  | 4  | ○    |
| 44454B11 | 11,5  | 4  | ●    |



**Bowl**

Ciotola  
Schüssel  
Bol  
Bol Ensalada

| art.     | dim. cm. | col. |
|----------|----------|------|
| 44455-09 | 9x7x2,5  | ○    |
| 44455B09 | 9x7x2,5  | ●    |



**Bowl**

Ciotola  
Schüssel  
Bol  
Bol Ensalada

| art.     | dim. cm. | col. |
|----------|----------|------|
| 44456-14 | 14x9x2,5 | ○    |
| 44456B14 | 14x9x2,5 | ●    |



**Bowl**

Ciotola  
Schüssel  
Bol  
Bol Ensalada

| art.     | dim. cm.  | col. |
|----------|-----------|------|
| 44457-32 | 32,5x14x4 | ○    |
| 44457B32 | 32,5x14x4 | ●    |



**Tray**

Vassoio  
Platte  
Plateau  
Placa

| art.     | dim. cm.  | col. |
|----------|-----------|------|
| 44461-20 | 20x20x4,5 | ○    |
| 44461B20 | 20x20x4,5 | ●    |



**Bowl**

Ciotola  
Schüssel  
Bol

Bol Ensalada

| art.     | dim. cm. | col. |
|----------|----------|------|
| 44450-21 | 21x21x11 | ○    |
| 44450B21 | 21x21x11 | ●    |



**Bowl**

Ciotola  
Schüssel  
Bol

Bol Ensalada

| art.     | dim. cm. | col. |
|----------|----------|------|
| 44450-12 | 12x12x4  | ○    |
| 44450B12 | 12x12x4  | ●    |



**Bowl**

Ciotola  
Schüssel  
Bol

Bol Ensalada

| art.     | dim. cm.    | col. |
|----------|-------------|------|
| 44450-17 | 17,5x17,5x7 | ○    |
| 44450B17 | 17,5x17,5x7 | ●    |



**Tray**

Vassoio  
Platte  
Plateau  
Placa

| art.     | dim. cm. | col. |
|----------|----------|------|
| 44451-22 | 22x12x3  | ○    |
| 44451B22 | 22x12x3  | ●    |



**Tray**

Vassoio  
Platte  
Plateau  
Placa

| art.     | dim. cm.  | col. |
|----------|-----------|------|
| 44462-25 | 25x25x5,5 | ○    |
| 44462B25 | 25x25x5,5 | ●    |



**Dish**

Piatto  
Teller  
Assiette  
Plato

| art.     | Ø cm. | h. | col. |
|----------|-------|----|------|
| 44459-28 | 28    | 3  | ○    |
| 44459B28 | 28    | 3  | ●    |



**Bowl**

Ciotola  
Schüssel  
Bol

Bol Ensalada

| art.     | dim. cm. | h. | col. |
|----------|----------|----|------|
| 44450-11 | 11x10    | 3  | ○    |
| 44450B11 | 11x10    | 3  | ●    |



**Bowl**

Ciotola  
Schüssel  
Bol

Bol Ensalada

| art.     | dim. cm. | h.  | col. |
|----------|----------|-----|------|
| 44450-13 | 13x11    | 3,5 | ○    |
| 44450B13 | 13x11    | 3,5 | ●    |



**Bowl**

Ciotola  
Schüssel  
Bol

Bol Ensalada

| art.     | dim. cm.      | col. |
|----------|---------------|------|
| 44450-15 | 17,5x15,5x5,5 | ○    |
| 44450B15 | 17,5x15,5x5,5 | ●    |



**Tray**

Vassoio  
Platte  
Plateau  
Placa

| art.     | dim. cm.    | col. |
|----------|-------------|------|
| 44450-23 | 22x23,5x5,5 | ○    |
| 44450B23 | 22x23,5x5,5 | ●    |





MF

**Soup/rice bowl with lid**  
Ciotola riso con coperchio  
Reisschüssel mit Deckel  
Bol à riz avec couvercle  
Bol arroz con tapa

| art.     | Ø cm. | h. |
|----------|-------|----|
| 49655-34 | 10    | 10 |



MF

**Towel tray**  
Vassoio portatovagliolo  
Handtuch-Tablett  
Plateau à serviette  
Bandeja servilleta

| art.     | dim. cm. |
|----------|----------|
| 49655-46 | 17x7     |



MF

**Bento tray**  
Vassoio bento  
Bento-Platte  
Plateau à bento  
Bandeja bento

| art.     | dim. cm.  |
|----------|-----------|
| 49655-36 | 22x16x3,5 |



MF

**Bento box with lid**  
Scatola bento con coperchio  
Bento-Box mit Deckel  
Boîte à bento avec couvercle  
Caja bento con tapa

| art.     | dim. cm. |
|----------|----------|
| 49655-44 | 30x24    |



MF

**Bento box with lid**  
Scatola bento con coperchio  
Bento-Box mit Deckel  
Boîte à bento avec couvercle  
Caja bento con tapa

| art.     | dim. cm.  |
|----------|-----------|
| 49655-37 | 24x24x5,5 |



NEW

MF

**Bento box with lid 7 pcs**  
Scatola bento con coperchio 7 pz  
Bento-Box mit Deckel 7-tlg  
Boîte à bento avec couvercle 7 pcs  
Caja bento con tapa 7 pz

| art.     | dim. cm. |
|----------|----------|
| 44357-07 | 30x25x8  |



MF

**Sushi serving dish**  
Piatto a servire  
Sushi-Servierteller  
Plat à sushi  
Plato para sushi

| art.     | Ø cm. | h.  |
|----------|-------|-----|
| 49655-21 | 22    | 5,5 |
| 49655-22 | 25    | 6   |
| 49655-23 | 28    | 6   |



MF

**Sushi-sashimi bridge**  
Ponte per sushi e sashimi  
Sushi-Brücke  
Sushi et sashimi pont  
Puente para sushi-sashimi

| art.     | dim. cm.  |
|----------|-----------|
| 49655-41 | 28x13,5x6 |



B

**Sushi geta board**  
Tagliere sushi  
Sushibrett  
Planche à sushi  
Tabla para sushi

| art.     | dim. cm. |
|----------|----------|
| 49655-24 | 24x15x3  |



MF

**Hand roll stand, laquered**  
Supporto per temaki, laccato  
Temaki-Ständer  
Support pour temaki  
Soporte para temaki

| art.     | dim. cm. |
|----------|----------|
| 49655-32 | 18x9,5x8 |



W

**Hand roll stand**  
Supporto per temaki  
Temaki-Ständer  
Support pour temaki  
Soporte para temaki

| art.     | dim. cm. |
|----------|----------|
| 49655-31 | 18x9x8,5 |



MF

**Sushi-sashimi boat**

Barca per sushi e sashimi  
Sushi-Sashimi-Boot  
Bateau sushi et sashimi  
Barco sushi-sashimi

art. dim. cm.  
49655-45 28x13,5x6



B

**Sushi-sashimi boat**

Barca per sushi e sashimi  
Sushi-Sashimi-Boot  
Bateau sushi et sashimi  
Barco sushi-sashimi

art. dim. cm.  
49655-29 34x12x10,5



MF

**Soup spoon**

Cucchiaio brodo  
Suppenlöffel  
Cuiller à soupe  
Cuchara sopa

art. dim. cm. col.  
44850-13 13,5x4,5 ○  
44850B13 13,5x4,5 ●



MF

**Soup spoon**

Cucchiaio brodo  
Suppenlöffel  
Cuiller à soupe  
Cuchara sopa

art. l. cm.  
49655-35 14,5



PR

**Sauce pourer**

Salsiera  
Sauciere  
Saucière  
Salsera

| art.     | dim. cm. | lt.  | U. Pack |
|----------|----------|------|---------|
| 67305-57 | 7x11     | 0,2  | 6       |
| 67308-57 | 5x4      | 0,03 | 6       |



PR

**Flat plate**

Piattino piano  
Teller flach  
Petite assiette plate  
Platillo llano

| art.     | dim. cm. | U. Pack |
|----------|----------|---------|
| 67303Q80 | 9x9      | 6       |
| 67303Q81 | 12x12    | 6       |



PR

**Deep plate**

Piattino fondo  
Teller tief  
Petite assiette creuse  
Platillo hondo

| art.     | dim. cm. | U. Pack |
|----------|----------|---------|
| 67303Q82 | 9x9      | 6       |
| 67303Q83 | 12x12    | 6       |



PR

**Small dish**

Ciotolina  
Schale  
Petite assiette  
Platillo

| art.     | dim. cm. | U. Pack |
|----------|----------|---------|
| 67303M01 | 9x7x3    | 6       |



PR

**Small dish**

Piattino  
Schale  
Petite assiette  
Platillo

| art.     | Ø cm. | h. | U. Pack |
|----------|-------|----|---------|
| 67303M04 | 10,5  | 2  | 6       |



PR

**Small dish**

Piattino  
Schale  
Petite assiette  
Platillo

| art.     | dim. cm. | U. Pack |
|----------|----------|---------|
| 67303M02 | 14x7x2   | 6       |



PR

**Small dish**

Ciotolina  
Schale  
Petite assiette  
Platillo

| art.     | Ø cm. | h. | U. Pack |
|----------|-------|----|---------|
| 67303M03 | 10    | 2  | 6       |



PR

**Small dish**

Ciotolina  
Schale  
Petite assiette  
Platillo

| art.     | dim. cm. | U. Pack |
|----------|----------|---------|
| 67303M05 | 11x8     | 6       |
| 67303M06 | 16x11    | 6       |





PR

**Chinese spoon**  
Cucchiaio cinesee  
Löffel  
Cuillère chinoise  
Cucharita

| art.     | l. cm. | U. Pack |
|----------|--------|---------|
| 67303M07 | 13     | 12      |



PR

**Sake jug**  
Caraffa sake  
Sakekrug  
Carafe à sake  
Jarra sake

| art.     | Ø cm. | h.   | ml. | col. |
|----------|-------|------|-----|------|
| 49655-25 | 5,2   | 13,5 | 120 | ○    |
| 49655-42 | 5,7   | 18,0 | 250 | ○    |



PR

**Sake jug**  
Caraffa sake  
Sakekrug  
Carafe à sake  
Jarra sake

| art.     | Ø cm. | h.   | ml. | col. |
|----------|-------|------|-----|------|
| 49655-57 | 5,2   | 13,5 | 130 | ●    |
| 49655-58 | 5,7   | 18,0 | 230 | ●    |



PR

**Sake cup**  
Coppetta sake  
Sakebecher  
Coupe à sake  
Copa sake

| art.     | Ø cm. | h.  | ml. |
|----------|-------|-----|-----|
| 49655-26 | 4,5   | 4,5 | 40  |



PR

**Sake cup**  
Coppetta sake  
Sakebecher  
Coupe à sake  
Copa sake

| art.     | Ø cm. | h.  | ml. | col. |
|----------|-------|-----|-----|------|
| 49655-43 | 4,5   | 5,5 | 40  | ○    |
| 49655-60 | 4,5   | 5,5 | 40  | ●    |



PR

**Sake cup**  
Coppetta sake  
Sakebecher  
Coupe à sake  
Copa sake

| art.     | Ø cm. | h. |
|----------|-------|----|
| 49655-56 | 5     | 4  |



PR

**Sake jug**  
Caraffa sake  
Sakekrug  
Carafe à sake  
Jarra sake

| art.     | Ø cm. | h.  |
|----------|-------|-----|
| 49655-55 | 6     | 9,5 |



PR

**Sake warmer**  
Riscalda sake  
Sakewärmer  
Réchaud à sake  
Calentador de sake

| art.     | Ø cm. | h. |
|----------|-------|----|
| 49655-54 | 9,5   | 9  |



PR

**Soy pot**  
Vaso soia  
Sojakrug  
Carafe soja sauce  
Jarra soja

| art.     | Ø cm. | h.  |
|----------|-------|-----|
| 49655-52 | 12    | 7,5 |



PR

**Soy pot**  
Vaso soia  
Sojakrug  
Carafe soja sauce  
Jarra soja

| art.     | Ø cm. | h. |
|----------|-------|----|
| 49655-51 | 6,5   | 7  |



PR

**Soy pot**  
Vaso soia  
Sojakrug  
Carafe soja sauce  
Jarra soja

| art.     | Ø cm. | h.  | ml. |
|----------|-------|-----|-----|
| 49655-53 | 5,5   | 8,5 | 130 |



NEW



**Teapot**  
Teiera  
Teekanne  
Théière  
Tetera

| art.     | dim. cm. | h. | lt. |
|----------|----------|----|-----|
| 49655-70 | 19,5x18  | 15 | 0,8 |

**Cast iron with s/steel strainer. For 2-3 cups.**  
In ghisa con colino inox. Per 2-3 tazze.



NEW



**Teapot warmer**

Rechaud  
Stövchen  
Chauffe-théière  
Calentador

| art.     | Ø cm. | h. mm. |
|----------|-------|--------|
| 49655-72 | 13    | 7,5    |



NEW



**Teapot**

Teiera  
Teekanne  
Théière  
Tetera

| art.     | dim. cm. | h.   | lt. |
|----------|----------|------|-----|
| 49655-80 | 12,5x11  | 12,5 | 0,3 |

**Cast iron, without tea strainer.**  
In ghisa, senza colino.



NEW



**Coaster**

Sottoteiera  
Untersetzer  
Repose théière  
Reposa tetera

| art.     | Ø cm. | h. mm. |
|----------|-------|--------|
| 49655-81 | 13,5  | 1,5    |

**Cast iron with non-slip feet.**  
In ghisa con piedini antiscivolo.



NEW

B



**Tray**

Vassoio  
Tablett  
Plateau  
Bandeja

| art.     | GN  | dim. cm.    |
|----------|-----|-------------|
| 49655-86 | 1/2 | 32,5x26,5x3 |
| 49655-87 | 1/3 | 32,5x17,6x3 |
| 49655-88 | 2/4 | 53x16,2x3   |



PR

**Chopstick rest**

Supporto bacchette cinesi  
Ess-Stäbchen Ablage  
Pose baguettes  
Soporte para palillos

| art.     | dim. cm. | col. |
|----------|----------|------|
| 49655-27 | 4,5x3    | ●    |
| 49655-28 | 4,5x3    | ○    |



PR

**Chopstick rest**

Supporto bacchette cinesi  
Ess-Stäbchen Ablage  
Pose baguettes  
Soporte para palillos

| art.     | dim. cm. |
|----------|----------|
| 49655-61 | 6x1,5    |



MF

**Chopsticks**

Bacchette cinesi  
Ess-Stäbchen  
Baguettes  
Palillos

| art.     | l. cm. | pairs/paia |
|----------|--------|------------|
| 49658-01 | 27     | 10         |



**MF**

**Chopsticks**

Bacchette cinesi  
Ess-Stäbchen  
Baguettes  
Palillos

| art.     | l. cm. | pairs/paia |
|----------|--------|------------|
| 49658-02 | 27     | 10         |



**B**

**Disposable chopsticks**

Bacchette monouso  
Einweg Ess-Stäbchen  
Baguettes jetables  
Palillos desechables

| art.     | l. cm. | pairs/paia |
|----------|--------|------------|
| 48300-29 | 21     | 50         |



**B**

**Disposable chopsticks**

Bacchette monouso  
Einweg Ess-Stäbchen  
Baguettes jetables  
Palillos desechables

| art.     | l. cm. | pairs/paia |
|----------|--------|------------|
| 49627-22 | 24     | 100        |



**Japanese chopsticks**

Bacchette giapponesi  
Japanische-Ess-Stäbchen  
Baguettes japonaises  
Palillos japoneses

| art.     | l. cm. | pairs/paia |
|----------|--------|------------|
| 49628-00 | 24     | 1          |

**Assorted colors. – Colori assortiti.**



**SS**

**Japanese chopsticks**

Bacchette giapponesi  
Japanische-Ess-Stäbchen  
Baguettes japonaises  
Palillos japoneses

| art.     | l. cm. | pairs/paia |
|----------|--------|------------|
| 49655-30 | 23     | 5          |



**B**

**Noshikushi skewers**

Spiedini noshikushi  
Noshikushi Spieße  
Brochettes noshikushi  
Pinchos noshikushi

| art.     | l. cm. | pcs/pz |
|----------|--------|--------|
| 48300-42 | 10,5   | 100    |



**B**

**Tepokushi skewers**

Spiedini tepokushi  
Tepokushi Spieße  
Brochettes tepokushi  
Pinchos tepokushi

| art.     | l. cm. | pcs/pz |
|----------|--------|--------|
| 48300-43 | 9      | 100    |
| 48300-33 | 15     | 100    |



**W**

**Mooncake mould flower**

Stampo mooncake flower  
Mondkuchenform Flower  
Moule à mooncake flower  
Molde mooncake flower

|      |          |
|------|----------|
| art. | 49664-01 |
|------|----------|



**W**

**Mooncake mould fish**

Stampo mooncake fish  
Mondkuchenform Fish  
Moule à mooncake fish  
Molde mooncake fish

|      |          |
|------|----------|
| art. | 49664-02 |
|------|----------|



**W**

**Mooncake mould long life**

Stampo mooncake long life  
Mondkuchenform Long Life  
Moule à mooncake long life  
Molde mooncake long life

|      |          |
|------|----------|
| art. | 49664-03 |
|------|----------|



**W**

**Mooncake mould long life acadia**

Stampo mooncake long life acadia  
Mondkuchenform Long Life Acadia  
Moule à mooncake long life acadia  
Molde mooncake long life acadia

|      |          |
|------|----------|
| art. | 49664-04 |
|------|----------|



**W**

**Mooncake mould double flower**

Stampo mooncake double flower  
Mondkuchenform Double Flower  
Moule à mooncake double flower  
Molde mooncake double flower

|      |          |
|------|----------|
| art. | 49664-05 |
|------|----------|



B

**Sushi mat**  
Stuoietta  
Sushi-Matte  
Natte à rouler les sushis  
Mantelín para sushi

| art.     | dim. cm. |
|----------|----------|
| 49626-00 | 24x24    |



B

**Sushi mat**  
Stuoietta  
Sushi-Matte  
Natte à rouler les sushis  
Mantelín para sushi

| art.     | dim. cm. |
|----------|----------|
| 49626-02 | 27x27    |



**Sushi-maki set 3 pcs**  
Kit 3 pz per sushi-maki  
Sushi-Maki-Satz 3 Stk  
Kit 3 pcs pour réaliser les sushi-maki  
Juego 3 pz para sushi-maki

| art.     | dim. cm. |
|----------|----------|
| 49655-02 | 26x7,5x6 |



**Maki roll mould**  
Stampo per maki  
Maki-Ausstechform  
Moule à maki  
Molde para maki

| art.     | dim. cm. |
|----------|----------|
| 49655-10 | 20,5x4x4 |



**Nigiri mould**  
Stampo per nigiri  
Nigiri-Ausstechform  
Moule à nigiri  
Molde para nigiri

| art.     | dim. cm. |
|----------|----------|
| 49655-16 | 16x6x2,5 |



MF

**Rice spoon**  
Cucchiaio riso  
Reislöffel  
Cuiller à riz  
Cuchara arroz

| art.     | dim. cm. |
|----------|----------|
| 49655-03 | 22x7     |



B

**Steamer**  
Cuocivapore  
Dampfgarer  
Panier vapeur  
Vaporera

| art.     | Ø cm. |
|----------|-------|
| 49603-15 | 16    |
| 49603-20 | 20    |
| 49603-25 | 25    |
| 49603-30 | 30    |
| 49603-40 | 40    |
| 49603-50 | 50    |

2 bodies + 1 cover. – 2 ceste + 1 coperchio.



B

**Steamer**  
Cuocivapore  
Dampfgarer  
Panier vapeur  
Vaporera

| art.     | dim. cm.  |
|----------|-----------|
| 49656-15 | 15,2x15,2 |
| 49656-16 | 16,5x16,5 |
| 49656-20 | 20,3x20,3 |





**W**

**Hangiri/sushi rice tub**

Vasca riso hangiri  
Hangiri/Sushi-Reis-Wanne  
Cuve è riz sushi/hangiri  
Barril arroz sushi/hangiri

| art.     | Ø cm. |
|----------|-------|
| 49655-49 | 45    |
| 49655-50 | 60    |



**Serving basket sticky rice**

Contentitore per riso dolce  
Klebreis-Servierkorb  
Panier de service à riz gluant  
Cesta para servir arroz pegado

| art.     | Ø cm. |
|----------|-------|
| 49660-09 | 9,5   |
| 49660-13 | 13,0  |

**Bamboo.**



**Sticky rice lao pot**

Pentola per riso dolce  
Klebreis Laotopf  
Marmite à riz gluant  
Olla para arroz pegado

| art.     | Ø cm. |
|----------|-------|
| 49661-22 | 22    |
| 49661-24 | 24    |

**Aluminum. – Alluminio.**



**Sticky rice lao basket**

Cesto per riso dolce  
Klebreis-Laokorb  
Panier cuisson à riz gluant  
Cesta de cocción arroz pegado

| art.     | Ø cm. |
|----------|-------|
| 49662-40 | 40    |
| 49662-50 | 50    |

**Bamboo.**



**Sticky rice cooking set**

Set cottura riso dolce  
Klebreis Kochset  
Ensemble de cuisson riz gluant  
Set de cocina arroz pegado

| art.     | Ø cm. |
|----------|-------|
| 49663-22 | 22    |
| 49663-24 | 24    |

**Aluminum and bamboo. – Alluminio e bamboo.**



**Wok with grid and cover, 3-ply**

Wok c/griglia e coperchio, 3-ply  
Wok mit Rost und Deckel, 3-ply  
Wok avec grille et couvercle, 3-ply  
Wok con rejilla y tapa, 3-ply

| art.     | Ø cm. | h. |
|----------|-------|----|
| 12529-32 | 32    | 8  |



**Steel wok pan**

Wok, ferro  
Wok-Eisenpfanne  
Poêle chinoise, acier  
Wok, hierro

| art.     | Ø cm. | h. |
|----------|-------|----|
| 11713-32 | 32    | 10 |
| 11713-40 | 40    | 11 |



**Steel wok pan**

Wok, ferro  
Wok-Eisenpfanne  
Poêle chinoise, acier  
Wok, hierro

| art.     | Ø cm. | h. |
|----------|-------|----|
| 49604-31 | 30,5  | 9  |
| 49604-36 | 35,5  | 11 |
| 49604-41 | 40,5  | 12 |



**Non stick wok**

Wok antiaderente  
Wok-Pfanne, nichttafend  
Poêle chinoise, anti-adhérente  
Wok, antiaderente

| art.     | Ø cm. |
|----------|-------|
| 49612-30 | 30,5  |
| 49612-33 | 33,0  |



**Wok stand, chromed**

Base per wok, cromata  
Fuss für Wokpfanne, verchromt  
Base pour wok, chromée  
Base para Wok, cromada

| art.     | Ø cm. | h.  |
|----------|-------|-----|
| 49600-00 | 20-25 | 5,5 |



**Rice steamer shelf**

Supporto per cottura a vapore  
Reis-Dampfer-Fuss  
Étagère à vapeur  
Estante de cocción al vapor

| art.     | Ø cm. | h.  |
|----------|-------|-----|
| 49653-10 | 10,0  | 7,5 |
| 49653-12 | 12,5  | 7,5 |
| 49653-15 | 15,0  | 7,5 |
| 49653-17 | 18,0  | 7,5 |
| 49653-20 | 20,0  | 7,5 |

SS



**Rice steamer shelf**

Supporto per cottura a vapore  
Reis-Dampfer-Fuss  
Étagère à vapeur  
Estante de cocción al vapor

| art.     | Ø cm. | h.  |
|----------|-------|-----|
| 49652-10 | 10,0  | 2,5 |
| 49652-12 | 12,5  | 2,5 |
| 49652-15 | 15,0  | 2,5 |
| 49652-17 | 18,0  | 2,5 |
| 49652-20 | 20,0  | 2,5 |

SS

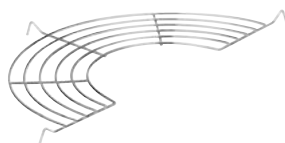

**Tempura rack, chromed**

Griglia per tempura, cromata  
Tempura-Rost, verchromt  
Grille à tempura, chromée  
Rejilla para tempura, cromada

| art.     | Ø cm. |
|----------|-------|
| 49613-30 | 30,5  |
| 49613-33 | 33,0  |
| 49613-35 | 35,5  |

Flat bottom. – Fondo piano.

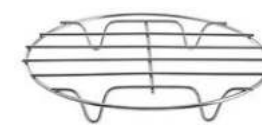

**Steam rack**

Griglia per cottura a vapore  
Dämpf-Rost  
Grille à vapeur  
Rejilla

| art.     | Ø cm. |
|----------|-------|
| 49654-15 | 15,2  |
| 49654-20 | 20,3  |
| 49654-25 | 25,4  |

SS



**Dim Sum steam rack**

Griglia Dim Sum  
Dim Sum Dämpf-Rost  
Grille Dim Sum  
Rejilla Dim Sum

| art.     | Ø cm. |
|----------|-------|
| 49659-24 | 24,0  |
| 49659-26 | 26,0  |

SS



**Steel wok pan**

Wok, ferro  
Wok-Eisenpfanne  
Poêle chinoise, acier  
Wok, hierro

| art.     | Ø cm. | h.   |
|----------|-------|------|
| 49605-46 | 45,5  | 14,0 |
| 49605-61 | 61,0  | 18,5 |
| 49605-71 | 71,0  | 22,0 |



**Wok lid, aluminum**

Coperchio per wok, alluminio  
Wok-Deckel, Aluminium  
Couvercle pour poêle chinoise, alu  
Tapa para wok, aluminio

| art.     | Ø cm. | h.   |
|----------|-------|------|
| 49602-25 | 24,5  | 4,5  |
| 49602-30 | 29,5  | 6,2  |
| 49602-33 | 32,0  | 9,0  |
| 49602-35 | 34,5  | 10,3 |



**Wok stand**

Base per wok  
Fuss für Wokpfanne  
Base pour wok  
Base para Wok

| art.     | Ø cm. |
|----------|-------|
| 11953-22 | 22    |

SS



**Agemono pot and stand**

Casseruola con supporto  
Kasserolle mit Untersetzer  
Casserole avec support  
Cacerola con soporte

| art.     | Ø cm. |
|----------|-------|
| 49655-64 | 20    |



**Toban skillet**

Padella Toban  
Toban-Pfanne  
Poêle Toban  
Sartén Toban

| art.     | Ø cm. |
|----------|-------|
| 49655-40 | 19    |





**Balti pan**

Padella balti/karahi

Balti-Pfanne

Poêle balti

Sartén balti

art. Ø cm.

49657-15 15,2

49657-20 20,3

49657-25 25,4

**Carbon steel. – Acciaio al carbonio.**



**Balti pan with wood base**

Padella balti base legno

Balti-Pfanne mit Holz-Basis

Poêle balti avec base en bois

Sartén balti base de madera

art. Ø cm.

49656-02 15,2

**Carbon steel. – Acciaio al carbonio.**



**Steel fry pan**

Padella per friggere, ferro

Frittier-Eisenpfanne

Tuile à frire, acier

Sartén freidora, hierro

art. Ø cm. h. lt.

41707-32 32 9,8 6,0

41707-36 36 11,0 8,8

41707-40 40 13,4 12,2

41707-45 45 15,0 17,3

41707-50 50 17,6 23,5



**Wire basket, tinned**

Cestello per friggere, stagnato

Frittier-Rost, verzinkt

Grille à frire, étamée

Cesta escurrefrito, estañada

art. Ø cm. h.

41708-32 32 11,0

41708-36 36 11,5

41708-40 40 12,4

41708-45 45 15,5

41708-50 50 16,5



**Japanese omelettes pan, non-stick**

Padella omelette, antiaderente

Japanische Omelette Pfanne mit

Antihaftbeschichtung

Poêle à omelettes, revêtement anti-adhésif

Sartén antiaderente para tortillas japonesas

art. dim. cm.

49655-38 22x24x3,5



**Tamagoyaki pan**

Padella Tamagoyaki

Tamagoyaki-Pfanne

Poêle à Tamagoyaki

Sartén Tamagoyaki

art. dim. cm.

49655-66 18x15x3



**Steel tawa pan**

Padella tawa, ferro

Tawa-Eisenpfanne

Poêle tawa, acier

Sartén tawa, hierro

art. Ø cm.

49614-28 28

**Used in Indian cooking, for chapattis and anything that needs quick cooking at high temperatures. – Utilizzate nella cucina indiana, per focacce e tutto ciò che ha bisogno di cottura rapida ad alta temperatura.**



**Chinese hot pot, aluminium**

Pentola cinese, alluminio

Chinese- Suppentopf, Alu

Marmite chinoise, alu

Olla chino, aluminio

art. Ø cm. h.

49616-22 22 17

49616-24 24 20

49616-26 26 22



SS

**Steamer**

Cuocivapore  
Dampf-Kocher  
Cuisieur à vapeur  
Cuscusera

| art.     | Ø cm. | h. |
|----------|-------|----|
| 49606-51 | 51    | 14 |
| 49606-00 | 51    | 14 |
| 49606-01 | 51    | 20 |



-01

-00

-51



**Scoop**

Porzionatore  
Portionierer  
Cuiller  
Racionador

| art.     |
|----------|
| 49616S01 |
| 49616B01 |



**Clay pot**

Casseruola terracotta  
Tontopf  
Pot d'argile  
Olla de barro

| art.     | Ø cm. | h. | Kg. |
|----------|-------|----|-----|
| 49632-24 | 23    | 10 | 1,5 |
| 49632-32 | 32    | 16 | 2,7 |



**Clay pot**

Casseruola terracotta  
Tontopf  
Pot d'argile  
Olla de barro

| art.     | Ø cm. | h. | Kg.  |
|----------|-------|----|------|
| 49633-22 | 22    | 10 | 0,75 |
| 49633-24 | 24    | 12 | 1,35 |



**Cast iron sizzler platter with wood**

Piatto ghisa con vassoio legno  
Gusseisenplatte mit Holzbrett  
Plat en fonte avec planche bois  
Fuente hierro fundido con tabla madera

| art.     | dim. cm. |
|----------|----------|
| 49615-01 | 33,5x22  |



**Mortar and pestle**

Mortaio e pestello  
Mörser und Stößel  
Mortier et pilon  
Mortero y pistilo

| art.     | Ø cm. | h.   | Kg. |
|----------|-------|------|-----|
| 49618-12 | 12,5  | 9,0  | 1,9 |
| 49618-15 | 15,0  | 10,0 | 3,2 |
| 49618-18 | 17,0  | 11,5 | 3,9 |



SS

**Wasabi grater**

Grattugia per wasabi  
Wasabi-Raffel  
Rape à wasabi  
Rallador para wasabi

| art.     | dim. cm. |
|----------|----------|
| 42555-11 | 11x7,5   |

**Dishwasher safe. To mash garlic, wasabi, ginger, horseradish. To grind almonds, nutmeg.**

Lavabile in lavastoviglie. Per grattugiare aglio, wasabi, zenzero, rafano, mandorle, noce moscata.



SS

**Oil pourer**

Oliera  
Ölkanne  
Huilière  
Alcuza

| art.     | ml.  |
|----------|------|
| 41780-05 | 500  |
| 41780-07 | 750  |
| 41780-09 | 1000 |





**Wonton noodle skimmer**

Schiumarola Wonton  
Wonton-Sieb  
Ecumoire à Wonton  
Colador para Wonton

| art.     | Ø cm. | h. |
|----------|-------|----|
| 49601-14 | 14    | 13 |

**Stainless steel and natural wood.**  
Inox e legno naturale.



**Chinese kitchen scissors**

Forbici cucina cinesi  
Chinesische Küchenschere  
Ciseaux de cuisine chinois  
Tijeras de cocina china

| art.     | dim. cm. |
|----------|----------|
| 49636-00 | 17x8,5   |

**Stainless steel and brass. – Inox e ottone.**



**Duck fur pincer**

Pinza per anatra  
Ente Fell Zange  
Pince à canard  
Pinza pato

| art.     | l. cm. |
|----------|--------|
| 49637-00 | 15     |



**Fish scaler**

Squamapesce  
Fischentschupper  
Ecailleur à poisson  
Escamador

| art.     | l. cm. |
|----------|--------|
| 49638-00 | 22     |



**Fry basket, coarse mesh**

Schiumarola fritto, rete grossa  
Frittierkorb  
Panier de friture  
Cesta para freír

| art.     | Ø cm. |
|----------|-------|
| 49607-15 | 15,0  |
| 49607-20 | 20,0  |
| 49607-25 | 25,5  |
| 49607-30 | 30,5  |

**Bamboo handle, stainless steel mesh.**  
Manico bamboo, rete inox.



**Fry basket, fine mesh**

Schiumarola fritto, rete fine  
Frittierkorb  
Panier de friture  
Cesta para freír

| art.     | Ø cm. |
|----------|-------|
| 49608-15 | 15,0  |
| 49608-20 | 20,0  |
| 49608-25 | 25,5  |
| 49608-30 | 30,5  |
| 49608-35 | 35,5  |

**Bamboo handle, stainless steel mesh.**  
Manico bamboo, rete inox.



**SS**

**Skimmer**

Schiumarola  
Schaumlöffel  
Ecumoire  
Espumadera

| art.     | Ø cm. | l. cm. |
|----------|-------|--------|
| 49617-23 | 24    | 45     |
| 49617-25 | 26    | 46     |
| 49617-30 | 30    | 50     |

**Stainless steel and natural wood.**  
Inox e legno naturale.



**Ladle**

Mestolo  
Schöpflöffel  
Louche  
Cacillo

| art.     | Ø cm. |
|----------|-------|
| 49609-12 | 11,8  |
| 49609-14 | 13,8  |

**Stainless steel and natural wood.**  
Inox e legno naturale.



**Spatula**

Paletta  
Teigschäber  
Spatule  
Espátula

| art.     | dim. cm. |
|----------|----------|
| 49610-11 | 11x10,2  |
| 49610-14 | 13,3x12  |

**Stainless steel and natural wood.**  
Inox e legno naturale.



**B**

**Cooking chopsticks**

Bastoncini per cucinare  
Kochstäbchen  
Baguettes de cuisine  
Palillos para cocinar

| art.     | l. cm. |
|----------|--------|
| 49629-45 | 45     |

**Disposable. – Monouso.**



**Wok brush**

Pennello per wok  
Wok-Pinsel  
Pinceaux à wok  
Pincel para wok

| art.     | l. cm. |
|----------|--------|
| 49634-00 | 25,5   |



**Wooden handled wok brush**

Spazzola per wook  
Wok-Bürste, Holzgriff  
Brosse à wok, manche bois  
Cepillo para wok, mango madera

| art.     | l. cm. |
|----------|--------|
| 49635-00 | 27,5   |

**Stainless steel and natural wood.**  
Inox e legno naturale.



# PIZZA

ETHNIC CUISINE  
CUCINA ETNICA





SS

**Oil pourer**

Oliera  
Ölkanne  
Huilière  
Alcuza

| art.     | lt.  |
|----------|------|
| 41780-05 | 0,50 |
| 41780-07 | 0,75 |
| 41780-09 | 1,00 |



**Oil pourer, copper**

Oliera, rame  
Ölkanne, Kupfer  
Huilière, cuivre  
Alcuza, cobre

| art.     | h. cm. | lt.  |
|----------|--------|------|
| 41781-05 | 23,0   | 0,50 |
| 41781-10 | 27,0   | 1,00 |
| 41781-15 | 31,5   | 1,50 |

**Tinned inside. – Interno stagnato.**



**Pizza peel, aluminum**

Pala pizza, alluminio  
Pizzaschaufel, Aluminum  
Pelle à pizza, aluminium  
Pala pizza, aluminio

| art.     | Ø cm. | l. cm. | gr.  |
|----------|-------|--------|------|
| 11701-02 | 32    | 150    | 736  |
| 11701-06 | 37    | 150    | 870  |
| 11701-10 | 41    | 150    | 1226 |
| 11701-13 | 45    | 150    | 1460 |
| 11701-16 | 50    | 150    | 1604 |



**Pizza peel, aluminum**

Pala pizza, alluminio  
Pizzaschaufel, Aluminum  
Pelle à pizza, aluminium  
Pala pizza, aluminio

| art.     | cm.   | l. cm. | gr.  |
|----------|-------|--------|------|
| 11702-02 | 32x32 | 150    | 784  |
| 11702-06 | 37x37 | 150    | 894  |
| 11702-10 | 41x41 | 150    | 1246 |
| 11702-16 | 50x50 | 150    | 1694 |



**Perforated pizza peel, aluminum**

Pala pizza forata, alluminio  
Pizzaschaufel, gelocht, Aluminum  
Pelle à pizza perforée, aluminium  
Pala pizza perforada, aluminio

| art.     | cm.   | l. cm. | gr.  |
|----------|-------|--------|------|
| 11704-02 | 32x32 | 150    | 700  |
| 11704-06 | 37x37 | 150    | 816  |
| 11704-13 | 45x45 | 150    | 1250 |
| 11704-16 | 50x50 | 150    | 1409 |



SS

**Pizza peel, small**

Palettino  
Pizzaschaufel, klein  
Petite pelle à pizza  
Pala pizza, pequeña

| art.     | Ø cm. | l. cm. | gr. |
|----------|-------|--------|-----|
| 11705-02 | 17    | 150    | 780 |
| 11705-06 | 20    | 150    | 846 |
| 11705-10 | 23    | 150    | 938 |
| 11705-14 | 26    | 150    | 984 |



SS

**Perforated pizza peel, small**

Palettino forato  
Pizzaschaufel, gelocht, klein  
Petite pelle à pizza perforée  
Pala pizza perforada, pequeña

| art.     | Ø cm. | l. cm. | gr. |
|----------|-------|--------|-----|
| 11706-02 | 17    | 150    | 770 |
| 11706-06 | 20    | 150    | 830 |
| 11706-10 | 23    | 150    | 912 |
| 11706-14 | 26    | 150    | 954 |



**Oven pizza peel, aluminum**

Pala per infornare, alluminio  
Back-Pizzaschaufel, Aluminum  
Pelle à enfourner, aluminium  
Pala para hornear, aluminio

| art.     | cm.   | l. cm. | gr.  |
|----------|-------|--------|------|
| 41765-32 | 32x32 | 150    | 1200 |
| 41765-37 | 37x37 | 150    | 1400 |
| 41765-41 | 41x41 | 150    | 1500 |
| 41765-45 | 45x45 | 150    | 1600 |
| 41765-50 | 50x50 | 150    | 1700 |



SS

**Oven pizza peel**

Pala per infornare  
Back-Pizzaschaufel  
Pelle à enfourner  
Pala para hornear

| art.     | Ø cm. | l. cm. | gr. |
|----------|-------|--------|-----|
| 41735-29 | 29    | 150    | 870 |

**Aluminum handle. – Manico alluminio.**





**Oven pizza peel, aluminum**

Pala per infornare, alluminio  
Back-Pizzaschaufel, Aluminum  
Pelle à enfourner, aluminum  
Pala para hornear, aluminio

| art.     | cm.   | l. cm. | gr. |
|----------|-------|--------|-----|
| 41736-32 | 32x30 | 150    | 954 |



SS

**Perforated pizza peel, small**

Palettino forato  
Pizzaschaufel, gelocht, klein  
Petite pelle à pizza perforée  
Pala pizza perforada, pequeña

| art.     | Ø cm. | l. cm. | gr. |
|----------|-------|--------|-----|
| 41737-17 | 17    | 150    | 890 |
| 41737-20 | 20    | 150    | 910 |
| 41737-23 | 23    | 150    | 960 |



SS

**Pizza peel, small**

Palettino  
Pizzaschaufel, klein  
Petite pelle à pizza  
Pala pizza, pequeña

| art.     | Ø cm. | l. cm. | gr.  |
|----------|-------|--------|------|
| 41738-17 | 17    | 150    | 905  |
| 41738-20 | 20    | 150    | 975  |
| 41738-23 | 23    | 150    | 1030 |



**Pizza peel, small, aluminum**

Palettino, alluminio  
Pizzaschaufel, klein, Aluminum  
Petite pelle à pizza, aluminum  
Pala pizza, pequeña, aluminio

| art.     | Ø cm. | l. cm. | gr. |
|----------|-------|--------|-----|
| 41735-20 | 20    | 150    | 800 |



W

**Pizza peel**

Pala pizza  
Pizzaschaufel  
Pelle à enfourner

**Pala pizza**

| art.     | Ø cm. | l. cm. |
|----------|-------|--------|
| 41764-28 | 28    | 125    |
| 41764-33 | 33    | 200    |
| 41764-40 | 40    | 200    |



SS

**Ash shovel**

Paleta cenere  
Asche-Schaufel  
Pelle à cendres  
Paleta recogedar cenizas

| art.     | cm.   | l. cm. |
|----------|-------|--------|
| 41768-21 | 21x31 | 173    |



SS

**Rake**

Rastrello  
Harke  
Râteau  
Rastrillo

| art.     | cm.   | l. cm. |
|----------|-------|--------|
| 41768-22 | 24x10 | 150    |



**Adjustable brush**

Spazzola orientabile  
Drehbare Bürste  
Brosse orientable  
Cepillo orientable

| art.     | cm.    | l. cm. |
|----------|--------|--------|
| 41767-20 | 20x6,5 | 155    |

Brass bristles. – Setole ottone.



**Adjustable brush**

Spazzola orientabile  
Drehbare Bürste  
Brosse orientable  
Cepillo orientable

| art.     | cm.  | l. cm. |
|----------|------|--------|
| 41766-27 | 27x7 | 150    |

Brass bristles. – Setole ottone.



**Adjustable brush**

Spazzola orientabile  
Drehbare Bürste  
Brosse orientable  
Cepillo orientable

| art.     | cm.  | l. cm. |
|----------|------|--------|
| 41766-16 | 16x5 | 150    |

Brass bristles. – Setole ottone.



**Adjustable brush**

Spazzola orientabile  
Drehbare Bürste  
Brosse orientable  
Cepillo orientable

| art.     | cm.  | l. cm. |
|----------|------|--------|
| 41766-14 | 14x7 | 150    |



**Adjustable brush**

Spazzola orientabile  
Drehbare Bürste  
Brosse orientable  
Cepillo orientable

| art.     | cm.    | l. cm. |
|----------|--------|--------|
| 41739-20 | 20x6,6 | 150    |





**Brush for grill cleaning**

Spazzola per griglia, setole in acciaio  
Grillenbürste mit Stahlborsten  
Brosser pour grille avec soies en acier  
Cepillo para parrilla con cerdas de acero

art. cm.  
41740-00 27x4x15



**Support for peels**

Poggia pala pizza  
Schaufelträger  
Support pour pelles à pizza  
Portapala para palas

art. cm. Kg.  
41769-36 41x16x39 3,0  
41769-50 53x16x39 3,5

SS



**Small pizza peel wall rack, aluminum**

Portapaleto da muro, alluminio  
Pizzaschaufel-Wandgestell, Aluminium  
Support mural petite pelle, aluminum  
Soporte mural de pala pizza, aluminio

art.  
41769-02



**Pizza peel wall rack, aluminum**

Appendi pala da muro, alluminio  
Pizzaschaufel-Wandgestell, Aluminium  
Support mural pour pelle, aluminum  
Soporte mural de pala pizza, aluminio

art.  
41769-01



**Double-sided brush**

Spazzola bi-facciale  
Bürste Deidseitig  
Brosse double face  
Cepillo doble

art. l. cm.  
41761-02 100



**Pizza peel rack**

Porta pale  
Ständer für Schaufeln  
Support pour pelles  
Soporte para pala

art. h. cm. Kg.  
41769-00 172 14

SS



**Pizza peel, marble base**

Porta pale, base marmo  
Ständer für Schaufeln  
Support pour pelles  
Soporte para pala

art. cm.  
41769G00 25x35x180



SS



**Adjustable brush**

Spazzola orientabile  
Drehbare Bürste  
Brosse orientable  
Cepillo orientable

art. cm. l. cm.  
41767G20 20x6 160



**Pizza peel, aluminum**

Pala pizza, alluminio  
Pizzaschaufel, Aluminium  
Pelle à pizza, aluminum  
Pala pizza, aluminio

art. cm. l. cm.  
41704G33 33x33 150  
41704G36 36x36 150



**Supplied WITHOUT peels. – Fornito SENZA pale.**

**Brass bristles. – Setole ottone.**



SS

**Perforated pizza peel, small**

Palettino forato  
Pizzaschaufel, gelocht, klein  
Petite pelle à pizza perforée  
Pala pizza perforada, pequeña

| art.     | Ø cm. | l. cm. |
|----------|-------|--------|
| 41737G20 | 20    | 150    |
| 41737G23 | 23    | 150    |



SS

**Pan gripper**

Pinza per teglie  
Pizzablech-Zange  
Pince à plaques  
Pinza fuente horns

| art.     | l. cm. |
|----------|--------|
| 42822-00 | 23     |



SS

**Pan gripper**

Pinza per teglie  
Pizzablech-Zange  
Pince à plaques  
Pinza fuente horns

| art.     | l. cm. |
|----------|--------|
| 18323-00 | 23     |



SS

**Pizza cutter**

Tronchetto tagliapizza  
Pizzaschneider  
Coupe-pizza  
Cortador de pizza

| art.     | Ø cm. | l. cm. |
|----------|-------|--------|
| 18324-00 | 13,5  | 19     |



SS

**Divisible pizza scissors**

Forbice pizza smontabile  
Pizzaschere, teilbar  
Ciseaux à pizza, divisible  
Tijeras para pizza desmontables

| art.     | l. cm. |
|----------|--------|
| 18276-00 | 25     |



SS

**Pizza wheel**

Rotella taglia pizza  
Pizzaschneider  
Roulette à pizza  
Ruleta cortapizzas

| art.     | Ø cm. |
|----------|-------|
| 18324-10 | 10    |



SS

**Pizza knife**

Coltello per pizzaiolo  
Pizzamesser  
Couteau à pizza  
Cuchillo para pizza

| art.     | l. cm. |
|----------|--------|
| 48280-45 | 23     |



SS

**Perforated spatula**

Paletta triangolare, forata  
Palette, gelocht  
Palette perforée  
Pala triangular perforada

| art.     | cm.   |
|----------|-------|
| 18301-01 | 12x15 |



SS

**Spatula**

Paletta triangolare  
Palette  
Palette  
Pala triangular

| art.     | cm.   |
|----------|-------|
| 18301-02 | 12x15 |



**Peel with handle, aluminum**

Pala manicata, alluminio  
Schaufel mit Griff, Aluminium  
Pelle avec manche, alu  
Pala con mango, aluminio

| art.     | Ø cm. |
|----------|-------|
| 42826-32 | 32    |
| 42826-37 | 37    |



SS

**Perforated peel with handle**

Pala manicata, forata  
Schaufel mit Griff, gelocht  
Pelle perforée avec manche  
Pala con mango, perforada

| art.     | cm.   |
|----------|-------|
| 18302-01 | 22x18 |



SS

**Peel with handle**

Pala manicata  
Schaufel mit Griff  
Pelle avec manche  
Pala con mango

| art.     | cm.   |
|----------|-------|
| 18302-02 | 22x18 |





**W**

**Round platter**

Vassoio rotondo  
Buchenholzbrett, rund  
Plateau rond  
Bandeja redonda

| art.     | Ø cm. | h. cm. |
|----------|-------|--------|
| 41774-33 | 33    | 1,2    |

**Beech wood.** – Faggio.



**W**

**Cutting board 1 portion**

Tagliere monoporzione  
Einzelportion Tablett  
Planche mono-portion  
Tabla monoporción

| art.     | cm.       |
|----------|-----------|
| 41775-34 | 34x20x1,2 |

**Beech wood.** – Faggio.



**MF**

**Round platter**

Vassoio rotondo  
Tablett, rund  
Plateau rond  
Bandeja redonda

| art.     | Ø cm. | h. mm. |
|----------|-------|--------|
| 44473-02 | 33    | 0,8    |
| 44473-03 | 43    | 0,8    |



**Pizza plate with wooden platter**

Piatto pizza con tagliere legno  
Pizzaplatte mit Holzbrett  
Plat pizza avec planche bois  
Fuente pizza con tabla madera

| art.     | Ø cm. |
|----------|-------|
| 44232S16 | 16    |
| 44232S20 | 20    |

**Enamelled cast iron plate.**

Piatto in ghisa smaltata.



**Pizza plate with wooden platter**

Piatto pizza con tagliere legno  
Pizzaplatte mit Holzbrett  
Plat pizza avec planche bois  
Fuente pizza con tabla madera

| art.     | Ø cm. |
|----------|-------|
| 44233-20 | 20    |

**Enamelled cast iron plate. Cups not included.**

Piatto in ghisa smaltata. Ciotoline non incluse.

**MODULAR SYSTEM BASE=LID EXTENSIBLE HEIGHT  
SISTEMA MODULARE BASE=COPERCHIO ALTEZZA ESTENSIBILE**



The modular system where the base and lid are the same element. Rotation system allows the steam of hot pizzas to escape.

Sistema modulare, la base e coperchio sono lo stesso elemento. Dotato di sistema rotabile, per la fuoriuscita del vapore delle pizze calde.



**PPE**

**Base and lid**

Base e coperchio  
Basis und Abdeckung  
Base et couvercle  
Base y tapa

| art.     | cm. ext.  | int.          |
|----------|-----------|---------------|
| 44975-35 | 41x41x7,5 | 35,2x35,2x4,5 |
| 44975-50 | 57x57x9,5 | 51x51x6,3     |



**PPE**

**Extender**

Estensore  
Aufsatz  
Réhausse  
Extensión

| art.     | cm. ext.  | int.          |
|----------|-----------|---------------|
| 44975H35 | 41x41x7,5 | 35,2x35,2x7,5 |
| 44975H50 | 57x57x9,5 | 51x51x7,5x9,5 |





PPE

**Insulated container**

Contenitore isotermico  
Thermobehälter  
Conteneur isotherme  
Contenedor isotérmico

| art.     | cm.        | lt. |
|----------|------------|-----|
| 44961-03 | 42x42x34,5 | 36  |

**With steam release system. For pizza boxes max 36x36 cm.** – Con sistema di rilascio del vapore. Per cartoni pizza max 36x36 cm.



PPE

**Insulated container with handle**

Contenitore isotermico con maniglia  
Thermobehälter mit Grill  
Conteneur isotherme avec manche  
Contenedor isotérmico con asa

| art.     | cm.        | lt. |
|----------|------------|-----|
| 44961M03 | 42x42x34,5 | 36  |

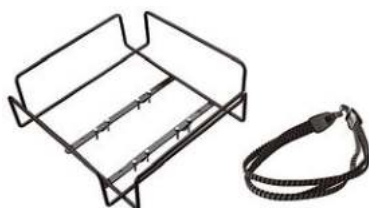

**Bike basket rack + elastic hook**

Cestello portapacco bike + gancio elastico  
Fahrradträgerkorb + elastischer Haken  
Porte-panier pour vélos + crochet élastique  
Canasta para bicicletas + gancho elástico

| art.     | cm.      |
|----------|----------|
| 44962-01 | 46x46x16 |

**With 8 self-locking screws. Max platform capacity 25 kg.** – Completo di 8 viti autobloccanti. Portata massima pianale 25 kg.



**Pizza delivery bag**

Borsa isotermica  
Thermo-Tasche  
Sac thermique  
Bolsa térmica

| art.     | cm.      | cap.  |
|----------|----------|-------|
| 44960-01 | 55x50x20 | 3xø45 |



**Pizza delivery bag**

Borsa isotermica  
Thermo-Tasche  
Sac thermique  
Bolsa térmica

| art.     | cm.      | cap.  |
|----------|----------|-------|
| 44960-04 | 46x44x20 | 4xø30 |



**Pizza delivery bag**

Borsa isotermica  
Thermo-Tasche  
Sac thermique  
Bolsa térmica

| art.     | cm.            | cap. |
|----------|----------------|------|
| 44960-06 | 34x34x19,5xø33 |      |
| 44960-07 | 42x42x19,4xø40 |      |



**Pizza delivery bag**

Borsa isotermica  
Thermo-Tasche  
Sac thermique  
Bolsa térmica

| art.     | cm.            | cap. |
|----------|----------------|------|
| 44960-02 | 46x46x12,2xø40 |      |
| 44960-03 | 50x51x11,2xø45 |      |





**Sandwich delivery bag**

Borsa isotermitica  
Thermo-Tasche  
Sac thermique  
Bolsa térmica

art. cm.  
44960-13 39x27x30



**Pizza delivery bag**

Borsa isotermitica  
Thermo-Tasche  
Sac thermique  
Bolsa térmica

art. cm.  
44960-10 51x46x41



**Pizza delivery bag**

Borsa isotermitica  
Thermo-Tasche  
Sac thermique  
Bolsa térmica

art. cm.  
44960-11 48x48x70



**Pizza delivery bag with rack**

Borsa isotermitica con rastrelliera  
Thermo-Tasche mit Gestell  
Sac thermique avec étagère  
Bolsa térmica con rack

art. cm. cap.  
44960K10 51x46x41 6xø45



**Pizza delivery bag with rack**

Borsa isotermitica con rastrelliera  
Thermo-Tasche mit Gestell  
Sac thermique avec étagère  
Bolsa térmica con rack

art. cm. cap.  
44960K11 48x48x70 10xø45



**Pizza delivery backpack**

Zaino isotermitico  
Thermo-Rucksack  
Sac à dos thermique  
Mochila térmica

art. cm.  
44962-05 45x45x38

**Polyester and nylon. With inner PP insulaed container. For pizza boxes up to 35x35 cm. – Poliestere e nylon. Interno con contenitore isotermitico in PP. Per scatole pizza fino a 35x35 cm.**





PP  
SS

**Dough scraper, flexible**

Tagliapasta flessibile  
Abstecher, flexibele  
Raclette flexible  
Cortapastas flexible

art. cm.  
18501-02 12x9,5



PP  
SS

**Dough scraper**

Tagliapasta  
Abstecher  
Raclette  
Cortapastas

art. cm.  
18501-01 12x16  
18501-03 13,5x10  
18501-04 12x9,5



PP  
SS

**Dough scraper**

Raschia  
Teigschäber  
Raclette  
Rasqueta

art. cm.  
18501-05 11x19,5



PP  
SS

**Dough scraper**

Raschia  
Teigschäber  
Raclette  
Rasqueta

art. cm.  
18502-18 18x9



PP  
SS

**Dough scraper**

Raschia  
Teigschäber  
Raclette  
Rasqueta

art. cm.  
18503-12 12x10



PP  
SS

**Dough scraper**

Raschia  
Teigschäber  
Raclette  
Rasqueta

art. cm.  
18504-15 15x7,5



PP  
SS

**Dough scraper**

Raschia  
Teigschäber  
Raclette  
Rasqueta

art. cm.  
18520-15 15x6



PA+  
plus

**Pizza ladle, flat bottom**

Mestolo pizza, fondo piatto  
Schöpföffel, flachboden  
Louche fond plat  
Cacillo fondo plano

art. Ø cm. l. cm.  
12968-10 10 27



PS

**Dough cutter**

Tagliapasta  
Teigschäber  
Raclette  
Rascador

art. cm.  
47621-11 10x24

**Shock and scratchproof material. Do not use on heat sources.** – Materiale antiurto e antigraffio. Non usare su fonti di calore.



PS

**Dough cutter**

Tagliapasta  
Teigschäber  
Raclette  
Rascador

art. cm.  
47621-12 13,5x14,5

**Shock and scratchproof material. Do not use on heat sources.** – Materiale antiurto e antigraffio. Non usare su fonti di calore.



PE

**Dough box**

Contenitore per impasti  
Behälter für Pizzateig  
Réceptier à pétrissage  
Contenedor para masa de pizza

art. cm. lt.  
41762-07 60x40x7,5 14  
41762-09 60x40x9,5 19  
41762-13 60x40x13 26



PE

**Cover for dough box**

Coperchio per contenitore  
Deckel für Pizzateig-Behälter  
Couvercle pour réceptier à pétrissage  
Tapa para contenedor

art. cm.  
41763-00 60x40



**Pizza screen, aluminum**  
Retina pizza, alluminio  
Pizzanetzscheibe, Aluminum  
Toile à pizza, aluminium  
Red para pizza, aluminio

| art.     | cm.   |
|----------|-------|
| 41734-60 | 60x40 |



**Pizza screen, aluminum**  
Retina pizza, alluminio  
Pizzanetzscheibe, Aluminum  
Toile à pizza, aluminium  
Red para pizza, aluminio

| art.     | Ø cm. |
|----------|-------|
| 41727-28 | 28    |
| 41727-30 | 30    |
| 41727-33 | 33    |
| 41727-36 | 36    |
| 41727-40 | 40    |

**Without seam. – Senza giunzione.**



**Pizza screen, aluminum**  
Retina pizza, alluminio  
Pizzanetzscheibe, Aluminum  
Toile à pizza, aluminium  
Red para pizza, aluminio

| art.     | Ø cm. |
|----------|-------|
| 41727-45 | 45    |
| 41727-50 | 50    |
| 41727-55 | 55    |
| 41727-60 | 60    |

**Without seam. – Senza giunzione.**



**SS**

**Pizza screen rack**  
Rastrelliera per retine  
Pizzanetzscheiben-Träger  
Etagère à toiles  
Rack para red para pizza

| art.     | cm.     |
|----------|---------|
| 41771-96 | 23x35,6 |

**Suitable for 96 screens.**  
Può contenere 96 retine.



**SS**

**Pizza pan rack**  
Rastelliera per teglie pizza  
Pizzableche-Träger  
Etagère pour plaques à pizza  
Rack para placas pizza

| art.     | cm.          |
|----------|--------------|
| 41770-15 | 30,5x30,5x70 |

**Rails h.3,5 cm. for sheets up to Ø 36 cm.**  
Distanza piani cm 3,5, per teglie max ø 36 cm.



**Baking tray, alusteel**  
Teglia forno, acciaio alluminato  
Backblech mit Aluminumüberzug  
Plaque à pizza, tôle aluminée  
Placa pizza, acero aluminizado

| art.     | Ø cm. | h. cm. | U. Pack |
|----------|-------|--------|---------|
| 11739-20 | 20    | 2,5    | 10      |
| 11739-24 | 24    | 2,5    | 10      |
| 11739-28 | 28    | 2,5    | 10      |
| 11739-32 | 32    | 2,5    | 10      |



**Pizza pan, heavy blue steel**  
Teglia pizza, ferro blu pesante  
Pizzablech, Blaublech, Schwerausführung  
Plaque à pizza, tôle forte bleuie  
Placa pizza, hierro pesante

| art.     | Ø cm. | h. cm. | U. Pack |
|----------|-------|--------|---------|
| 11744-20 | 20    | 2,5    | 10      |
| 11744-24 | 24    | 2,5    | 10      |
| 11744-28 | 28    | 2,5    | 10      |
| 11744-32 | 32    | 2,5    | 10      |



**Pizza pan, perforated, non stick coated**  
Teglia pizza forata, antiaderente  
Pizzablech, gelocht, beschichtet  
Plaque à pizza perforée, anti-adhésive  
Placa pizza perforada, antiaderente

| art.     | Ø cm. | h. cm. |
|----------|-------|--------|
| 41729-30 | 29/27 | 1,5    |
| 41729-34 | 33/30 | 1,5    |



**Pizza pan double non stick-coating**  
Teglia pizza, antiaderente a 2 strati  
Pizzablech mit Doppel-Beschichtung  
Plaque à pizza, double revêtement  
Placa pizza antiaderente, 2 capas

| art.     | Ø cm. | h. cm. | U. Pack |
|----------|-------|--------|---------|
| 11741-20 | 20    | 2,5    | 5       |
| 11741-24 | 24    | 2,5    | 5       |
| 11741-26 | 26    | 2,5    | 5       |
| 11741-28 | 28    | 2,5    | 5       |
| 11741-32 | 32    | 2,5    | 5       |

**Heat resistant up to 280°C. – Resistente a 280 °C.**



**Pizza pan, blue steel**

Teglia pizza, ferro blu  
Pizza-Blaublech  
Plaque à pizza, tôle bleuie  
Placa pizza, hierro

| art.     | Ø cm. | h. cm. | U. Pack |
|----------|-------|--------|---------|
| 11740-14 | 14    | 2,5    | 5       |
| 11740-16 | 16    | 2,5    | 5       |
| 11740-18 | 18    | 2,5    | 5       |
| 11740-20 | 20    | 2,5    | 5       |
| 11740-22 | 22    | 2,5    | 5       |
| 11740-24 | 24    | 2,5    | 5       |



**Pizza pan, blue steel**

Teglia pizza, ferro blu  
Pizza-Blaublech  
Plaque à pizza, tôle bleuie  
Placa pizza, hierro

| art.     | Ø cm. | h. cm. | U. Pack |
|----------|-------|--------|---------|
| 11740-26 | 26    | 2,5    | 5       |
| 11740-28 | 28    | 2,5    | 5       |
| 11740-30 | 30    | 2,5    | 5       |
| 11740-32 | 32    | 2,5    | 5       |
| 11740-36 | 36    | 2,5    | 5       |
| 11740-40 | 40    | 2,5    | 5       |



**Pizza pan, blue steel**

Teglia pizza, ferro blu  
Pizza-Blaublech  
Plaque à pizza, tôle bleuie  
Placa pizza, hierro

| art.     | Ø cm. | h. cm. | U. Pack |
|----------|-------|--------|---------|
| 11742-16 | 16    | 3,5    | 10      |
| 11742-18 | 18    | 3,5    | 10      |
| 11742-20 | 20    | 3,5    | 10      |
| 11742-22 | 22    | 3,5    | 10      |
| 11742-24 | 24    | 3,5    | 10      |
| 11742-26 | 26    | 3,5    | 10      |
| 11742-28 | 28    | 3,5    | 10      |



**Pizza pan, blue steel**

Teglia pizza, ferro blu  
Pizza-Blaublech  
Plaque à pizza, tôle bleuie  
Placa pizza, hierro

| art.     | Ø cm. | h. cm. | U. Pack |
|----------|-------|--------|---------|
| 11742-30 | 30    | 3,5    | 10      |
| 11742-32 | 32    | 3,5    | 5       |
| 11742-36 | 36    | 3,5    | 5       |
| 11742-40 | 40    | 3,5    | 5       |
| 11742-45 | 45    | 4,0    | 5       |
| 11742-50 | 50    | 4,0    | 5       |
| 11742-60 | 60    | 4,0    | 5       |



**Baking tray, blue steel, rectangular**

Teglia rettangolare, ferro blu  
Blaublech, rechteckig  
Plaque rectangulaire, tôle bleuie  
Placa rectangular, hierro

| art.     | cm.   | h. cm. |
|----------|-------|--------|
| 41745-30 | 30x23 | 3      |
| 41745-35 | 35x28 | 3      |
| 41745-40 | 40x30 | 3      |
| 41745-50 | 50x35 | 3      |
| 41745-60 | 60x40 | 3      |
| 41745-65 | 65x45 | 3      |



**Baking tray, alusteel**

Teglia, alluminata  
Backblech, Aluminiumüberzug  
Plaque rectangulaire, tôle aluminitée  
Placa rectangular, acero aluminizado

| art.     | cm.   | h. cm. |
|----------|-------|--------|
| 41746-60 | 60x40 | 2      |



**Baking tray, alusteel**

Teglia, alluminata  
Backblech, Aluminiumüberzug  
Plaque rectangulaire, tôle aluminitée  
Placa rectangular, acero aluminizado

| art.     | cm.   | h. cm. |
|----------|-------|--------|
| 41751-30 | 30x23 | 3      |
| 41751-35 | 35x28 | 3      |
| 41751-40 | 40x30 | 3      |
| 41751-50 | 50x35 | 3      |
| 41751-60 | 60x40 | 3      |
| 41751-65 | 65x45 | 3      |



**Baking tray, aluminum**

Teglia, alluminio  
Backblech, Aluminium  
Plaque à cuisson, aluminium  
Placa pastelería, aluminio

| art.     | cm.     | GN  |
|----------|---------|-----|
| 41744-32 | 53x32,5 | 1/1 |
| 41744-53 | 53x65   | 2/1 |
| 41744-60 | 60x40   | -   |



**Baking tray perforated, aluminum**

Teglia forata, alluminio  
Backblech, gelocht, Aluminium  
Plaque perforée, aluminium  
Placa perforada, aluminio

| art.      | cm.     |
|-----------|---------|
| 41756-30* | 30x40   |
| 41756-32  | 53x32,5 |
| 41756-53  | 53x65   |
| 41756-60  | 60x40   |

\* Open edges. – Angoli aperti.





**Baking tray, non stick coated**  
Teglia antiaderente  
Blech mit Antihafbeschichtung  
Plaque avec revêtement anti-adhésif  
Placa antiadherente

| art.     | cm.   | h. cm. |
|----------|-------|--------|
| 41747-60 | 60x40 | 2      |



**Baking tray, non stick coated**  
Teglia antiaderente  
Blech mit Antihafbeschichtung  
Plaque avec revêtement anti-adhésif  
Placa antiadherente

| art.     | Ø cm. | GN  | pcs/pz |
|----------|-------|-----|--------|
| 41755-11 | 12,5  | 1/1 | 6      |



**Baking tray, non stick coated**  
Teglia antiaderente  
Blech mit Antihafbeschichtung  
Plaque avec revêtement anti-adhésif  
Placa antiadherente

| art.     | cm.     | GN  |
|----------|---------|-----|
| 41743-32 | 53x32,5 | 1/1 |
| 41743-53 | 53x65   | 2/1 |
| 41743-60 | 60x40   | -   |



DEMARLE

**Baking tray, silicone coated**  
Teglia siliconata  
Backblech Silikonbeschichtet  
Plaque avec revêtement silicone  
Placa siliconada

| art.     | cm.     | GN  |
|----------|---------|-----|
| 41743D32 | 53x32,5 | 1/1 |
| 41743D53 | 53x65   | 2/1 |
| 41743D60 | 60x40   | -   |



**Baking tray perforated, non stick coated**  
Teglia forata, antiaderente  
Blech, gelocht mit Antihafbeschichtung  
Plaque perforée, revêtement anti-adhésif  
Placa perforada, antiadherente

| art.      | cm.     | GN  |
|-----------|---------|-----|
| 41753-30* | 30x40   | -   |
| 41753-32  | 53x32,5 | 1/1 |
| 41753-53  | 53x65   | 2/1 |
| 41753-60  | 60x40   | -   |

\* Open edges. – Angoli aperti.



DEMARLE

**Baking tray perforated, silicone coated**  
Teglia forata, siliconata  
Backblech, gelocht, Silikonbeschichtet  
Plaque perforée, revêtement silicone  
Placa perforada, siliconada

| art.     | cm.     | GN  |
|----------|---------|-----|
| 41753D30 | 30x40   | -   |
| 41753D32 | 53x32,5 | 1/1 |
| 41753D53 | 53x65   | 2/1 |
| 41753D60 | 60x40   | -   |



**Baking tray, alusteel**  
Teglia, alluminata  
Backblech, Aluminumüberzug  
Plaque, tôle aluminitée  
Placa, acero aluminizado

| art.     | Ø cm. | cm.   | pcs/pz |
|----------|-------|-------|--------|
| 41752-08 | 14    | 60x40 | 8      |
| 41752-12 | 12    | 60x40 | 12     |
| 41752-24 | 12    | 60x80 | 24     |



# COFFEE SHOP CAFFETTERIA

BAR HAPPY HOUR







**Nitro Whip**  
Sifone nitro  
Nitrobereiter  
Siphon à nitro  
Sifón para Nitro

| art.     | lt. | des.                  |
|----------|-----|-----------------------|
| 41452N10 | 1   | Whip/Sifone           |
| 41452N16 | -   | 16 chargers/ricariche |

**Nitro Brew is on one of the fastest growing trends in the coffee business. Offer Nitro Coffee, Nitro Tea, and Nitro Cocktails to delight your guests table/barside. Adding Nitrogen (N2) to cold brew coffee and cocktails initiates a spectacular cascading effect, making the beverage unique, attractive, and personal. Nitrogen creates a velvety creamy texture and a long lasting foamy head for brews and cocktails.** – Infusi Nitro è una delle tendenze in rapida crescita nel settore del caffè. Offri Nitro Caffè, Nitro Te e Nitro Cocktails per deliziare i tuoi ospiti. Aggiungendo l'azoto (N2) per preparare caffè e cocktail a freddo, viene avviato uno spettacolare effetto a cascata, rendendo la bevanda unica, attraente e personale. L'azoto crea una consistenza vellutata e cremosa e una spuma di lunga durata per infusi e cocktail.



**Set of 10 stencils, plastic**  
Kit 10 mascherine, plastica  
Satz 10 Masken, kunststoff  
Set 10 pcs masques, plastique  
Juego 10 máscaras, plástico

| art.     | Ø cm. | h. cm. | lt.  |
|----------|-------|--------|------|
| 47859-01 | 10    | 16     | 0,25 |



**Set of 10 stencils, plastic**  
Kit 10 mascherine, plastica  
Satz 10 Masken, kunststoff  
Set 10 pcs masques, plastique  
Juego 10 máscaras, plástico

| art.     | Ø cm. |
|----------|-------|
| 47859-02 | 10    |



**Set of 4 stencils, plastic**  
Kit 4 mascherine, plastica  
Satz 4 Masken, kunststoff  
Set 4 pcs masques, plastique  
Juego 4 máscaras, plástico

| art.     | Ø cm. |
|----------|-------|
| 47859-03 | 10    |



**Cocoa duster kit**  
Kit spargicacao  
Kakaostreuer-Set  
Set glacière à cacao  
Juego dosificador cacao

| art.     | Ø cm. | h. cm. |
|----------|-------|--------|
| 42923-07 | 6,5   | 13     |



**Cocoa dredger**  
Spargicacao  
Kakaostreuer  
Saupoudreuse à cacao  
Coctelera de cacao

| art.     | Ø cm. | h. cm. | ml. |
|----------|-------|--------|-----|
| 41607-00 | 5,5   | 7,5    | 160 |



**Sugar pourer**  
Spargizucchero  
Zuckerstreuer  
Saupoudreuse à sucre  
Dispensador de azúcar

| art.     | Ø cm. | Ø mm. | ml. |
|----------|-------|-------|-----|
| 47023-01 | 7     | 1,5   | 300 |
| 47023-02 | 7     | 2,5   | 300 |
| 47023-03 | 7     | 5     | 300 |
| 47023-04 | 7     | mesh  | 300 |



**Sugar pourer**  
Spargizucchero  
Zuckerstreuer  
Saupoudreuse à sucre  
Dispensador azúcar

| art.     | Ø cm. | h. cm. | ml. |
|----------|-------|--------|-----|
| 41525-01 | 8     | 15     | 250 |



**Sugar pourer**  
Spargizucchero  
Zuckerstreuer  
Saupoudreuse à sucre  
Dispensador azúcar

| art.     | Ø cm. | h. cm. | ml. |
|----------|-------|--------|-----|
| 42920-02 | 7,5   | 13,5   | 320 |



**Sugar pourer**  
Spargizucchero  
Zuckerstreuer  
Saupoudreuse à sucre  
Dispensador azúcar

| art.     | Ø cm. | h. cm. | ml. |
|----------|-------|--------|-----|
| 41645-00 | 7,5   | 17     | 320 |



**Honey/cream dispenser**  
Dosatore miele/cremiera  
Sahne-/Honigkännchen  
Doseur pour miel/lait  
Dosificador para miel/leche

| art.     | Ø cm. | h. cm. | ml. |
|----------|-------|--------|-----|
| 41525-00 | 8,5   | 13,5   | 300 |



**Milk frothing thermometers, 3 pcs**  
Termometri latte/barista, 3 pz  
Mich-Thermometer, 3 Stk  
Thermomètres à lait, 3 pièces  
Termómetros leche, 3 pz

| art.     | Ø cm. | scala | range     |
|----------|-------|-------|-----------|
| 49709-03 | 4,5   | 1°C   | -10+110°C |

**Red, green and blue, to easily identify different types of milk used, to avoid cross-contamination. Stem 175 mm.** – Rosso, verde e blu, per identificare facilmente i diversi tipi di latte utilizzati, per evitare la contaminazione incrociata. Stelo 175 mm.



**Milk pot with lid**  
Lattiera con coperchio  
Milchgießer mit Deckel  
Pot à lait avec couvercle  
Jarra leche con tapa

| art.     | lt.  |
|----------|------|
| 66303-01 | 0,15 |
| 66303-03 | 0,30 |
| 66303-06 | 0,60 |



**Cappuccino milk pot**  
Lattiera cappuccino  
Capuccino-Milchkanne  
Pot à cappuccino  
Jarra cappuccino

| art.     | lt. |
|----------|-----|
| 66307-06 | 0,6 |
| 66307-09 | 0,9 |
| 66307-12 | 1,2 |



**Spoon holder**  
Porta cucchiaini  
Kaffeelöffelbehälter  
Porte cuillères  
Porta cucharas

| art.     | Ø cm. | h. cm. |
|----------|-------|--------|
| 66313-03 | 6     | 9      |





SS

**Straw holder**

Porta cannucce  
Röhrchenbehälter  
Porte chalumeaux  
Porta pajitas

| art.     | Ø cm. | h. cm. |
|----------|-------|--------|
| 66313-06 | 8     | 12     |



SS

**Sugar packet holder**

Portabustine zucchero  
Zuckertütenschale  
Porte-sachet de sucre  
Porta sobres de azúcar

| art.     | dim. cm. |
|----------|----------|
| 66374-00 | 13x6x4   |



SS

**Sugar packet holder**

Portabustine zucchero  
Zuckertütenschale  
Porte-sachet de sucre  
Porta sobres de azúcar

| art.     | dim. cm. |
|----------|----------|
| 44104-15 | 9x7,5x5  |



PR

**Sugar packet holder**

Portabustine zucchero  
Zuckertütenschale  
Porte-sachet de sucre  
Porta sobres de azúcar

| art.     | dim. cm. |
|----------|----------|
| 67303-64 | 11x6x4   |



**Sugar packet holder**

Portabustine zucchero  
Zuckertütenschale  
Porte-sachet de sucre  
Porta sobres de azúcar

| art.     | dim. cm.  | col. |
|----------|-----------|------|
| 44104-01 | 8,5x6,5x5 | ●    |
| 44104-02 | 8,5x6,5x5 | ○    |



AY

**Tea-box**

Scatola portabustine tè  
Teebox  
Boîte à sachets de thé  
Caja para bolsitas de tè

| art.     | dim. cm. |
|----------|----------|
| 41614-22 | 22x17x9  |



W

**Tea-box**

Scatola portabustine tè  
Teebox  
Boîte à sachets de thé  
Caja para bolsitas de tè

| art.     | dim. cm.  |
|----------|-----------|
| 41614-33 | 33,5x20x9 |
| 41614-35 | 31x28x9   |



W

**Tea-box**

Scatola portabustine tè  
Teebox  
Boîte à sachets de thé  
Caja para bolsitas de tè

| art.     | dim. cm.  |
|----------|-----------|
| 41614-34 | 33,5x20x9 |
| 41614-36 | 31x28x9   |



PMMA

**Box With Lid**

Contentitore con coperchio  
Behälter mit Deckel  
Boîte avec couvercle  
Recipiente con tapa

| art.     | dim. cm.      |
|----------|---------------|
| 41472-25 | 27,5x10,5x9,5 |

**Single compartment 8,5x8 cm.**  
Singolo comparto 8,5x8 cm.



PMMA

**Napkin holder**

Portatovaglioli  
Serviettenhalter  
Porte serviettes  
Servilletero

| art.     | dim. cm. |
|----------|----------|
| 41472-12 | 18x6x10  |



PMMA

**Napkin holder**

Portatovaglioli  
Serviettenhalter  
Porte serviettes  
Servilletero

| art.     | dim. cm. |
|----------|----------|
| 41472-13 | 18x6x11  |



SS

**Napkin holder**

Portatovaglioli  
Serviettenhalter  
Porte serviettes  
Servilletero

| art.     | dim. cm. |
|----------|----------|
| 66391-00 | 10x3x8   |



SS

**Napkin holder**

Portatovaglioli  
Serviettenhalter  
Porte serviettes  
Servilletero

art. dim. cm.  
41602-00 17x3x7



SS

**Napkin holder**

Portatovaglioli  
Serviettenhalter  
Porte serviettes  
Servilletero

art. dim. cm.  
41601-17 8,5x11x12,5



**Napkin holder, chrome plated wire**

Portatovaglioli in filo cromato  
Serviettenhalter, Metall verchromt  
Porte-serviettes en fil chromé  
Servilletero en hilo cromado

art. dim. cm.  
41617-05 19x19x6,5



**Napkin holder, chrome plated wire**

Portatovaglioli in filo cromato  
Serviettenhalter, Metall verchromt  
Porte-serviettes en fil chromé  
Servilletero en hilo cromado

art. dim. cm.  
41617-15 19x19x19



**Napkin holder, chrome plated wire**

Portatovaglioli in filo cromato  
Serviettenhalter, Metall verchromt  
Porte-serviettes en fil chromé  
Servilletero en hilo cromado

art. dim. cm.  
41618-14 14x14x6,5



**Cash tray, 18 Cr s/s**

Vassoio conto, inox 18 Cr  
Rechnungstablett, Edelstahl 18 Cr  
Plateau porte-monnaie, inox 18 Cr  
Bandeja cuentas, acero 18 Cr

art. dim. cm.  
66318-19 19x14  
66318-22 22x15



SS

**Pastry stand 2-tier**

Alzata dolci, 2 piani  
Gebäckständer, 2-stufig  
Serviteur muet 2 étages  
Soporte dulces 2 niveles

art. Ø cm. h. cm.  
66339-02 12/16 20



**Serving stand, chrome plated**

Alzata cromata  
Serviergestell, Metall hartverchromt  
Présentoir chromé  
Soporte platos cromado

art. dim. cm.  
42962-26 18,5x15,5x26

For 3 plates max. Ø 17 cm, inside Ø 10,5 cm.  
Per 3 piatti max. Ø 17 cm, interno Ø 10,5 cm.



**Serving stand**

Alzata  
Serviergestell  
Présentoir  
Soporte platos

art. dim. cm.  
42962C26 18,5x15,5x26

For 3 plates max. Ø 17 cm, inside Ø 10,5 cm.  
Per 3 piatti max. Ø 17 cm, interno Ø 10,5 cm.





**W**

**Coffee set 4 pieces**

Servizio caffè 4 pezzi  
Kaffeeset 4 Stk  
Service à café 4 pièces  
Servicio de café 4 piezas

art. dim. cm.  
41206-03 25x18,7x2,5

**Acacia wood. – Acacia.**



**NEW**

**Serving stand 2-tier**

Alzata 2 piani  
Serviergestell, 2-stufig  
Présentoir 2 étages  
Soporte 2 niveles

art. dim. cm.  
41208-06 31x17x38

**Black metal frame with non-slip feet, 2 baskets 29x16x7 cm, 2 acacia wood boards 28,5x15,5x1,5 cm. – Struttura in metallo nero con piedini antiscivolo, 2 cesti cm 29x16x7, 2 assi in legno di acacia cm 28,5x15,5x1,5.**



**NEW**

**Serving stand 2-tier**

Alzata 2 piani  
Serviergestell, 2-stufig  
Présentoir 2 étages  
Soporte 2 niveles

art. Ø cm. h. cm.  
41208-02 22/26 48

**Wooden handle, metal black baskets Ø 22 H 6 cm and Ø 26 H 8 cm. – Manico legno, cesti in metallo nero Ø 22 H 6 cm e Ø 26 H 8 cm.**



**SS**

**Cake stand**

Alzata torta  
Tortenplatte  
Gueridon pâtissier  
Pedestal para tartas

art. Ø cm. h. cm.  
41538-30 30 5



**SS**

**Cake stand**

Alzata torta  
Tortenplatte  
Gueridon pâtissier  
Pedestal para tartas

art. Ø cm. h. cm.  
47099-30 30 10



**SS**

**Swivel cake stand**

Alzata torta girevole  
Tortenplatte drehbar  
Gueridon pâtissier tournante  
Pedestal giratorio para tartas

art. Ø cm. h. cm.  
47101-31 30,5 9

**Rotating plate. Fits to: 41414-31.  
Piatto rotante. Per art.: 41414-31.**



**MF**

**Cake stand**

Alzata torta  
Tortenplatte  
Gueridon pâtissier  
Pedestal para tartas

art. dim. cm.  
44874-08 31x31x8  
44874-16 31x31x16



**PS**

**Dome cover**

Cloche  
Abdeckehaube  
Cloche  
Campana

art. Ø cm. h. cm.  
41414-30 30 9,5

**Fits to/Per art.: 44845-31, 47101-31.**



**MF**

**Round dish**

Piatto tondo  
Platte, rund  
Plat rond

**Bandeja redonda**  
art. Ø cm. h. cm.  
44845-38 38 2



**Roll-top cover**  
Coperchio roll-top  
Rolltophaube  
Couvercle roll-top  
Campana roll-top

| art.     | Ø cm. | h. cm. |
|----------|-------|--------|
| 41447-38 | 38    | 20     |

**Fits to/Per art.: 44845-38.**



**Cake tray**  
Piatto torta  
Tortenplatte  
Plat gâteau  
Bandeja pasteles

| art.     | Ø cm. | h. cm. |
|----------|-------|--------|
| 44845-21 | 21,5  | 2,5    |
| 44845-31 | 31,0  | 3,5    |
| 44845-39 | 37,5  | 4,0    |

**With non-slip feet. With carved edge fixing the cover. – Con piedini antiscivolo. Con bordo fissa-coperchio.**



**Cake stand**  
Alzata torta  
Tortenplatte  
Gueridon pâtissier  
Pedestal para tartas

| art.     | Ø cm. | h. cm. |
|----------|-------|--------|
| 44873-06 | 21,5  | 9      |
| 44873-08 | 30,5  | 9      |
| 44873-10 | 37,5  | 9      |

**With non-slip feet. With carved edge fixing the cover. – Con piedini antiscivolo. Con bordo fissa-coperchio.**



**Cake stand**  
Alzata torta  
Tortenplatte  
Gueridon pâtissier  
Pedestal para tartas

| art.     | Ø cm. | h. cm. |
|----------|-------|--------|
| 44873-15 | 21,5  | 17     |
| 44873-16 | 30,5  | 17     |
| 44873-17 | 37,5  | 17     |

**With non-slip feet. With carved edge fixing the cover. – Con piedini antiscivolo. Con bordo fissa-coperchio.**



**Dome cover**  
Campana  
Haube  
Cloche  
Campana

| art.     | Ø cm. | h. cm. |
|----------|-------|--------|
| 41414-21 | 21    | 17     |

**Fits to/Per art.: 44475-82, 44475-83, 44474-24, 44474-25.**



**Dome cover**  
Campana  
Haube  
Cloche  
Campana

| art.     | Ø cm. | h. cm. |
|----------|-------|--------|
| 41414-31 | 30    | 22     |

**Fits to/Per art.: 41586-33, 41587-32, 44475-79, 44845-31, 44873-08, 44873-16, 47101-31, 44474-33, 44474-34.**

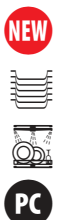

**Dome cover**  
Campana  
Haube  
Cloche  
Campana

| art.     | Ø cm. | h. cm. |
|----------|-------|--------|
| 41414-36 | 36    | 27     |

**Fits to/Per art.: 44474-38, 44474-39, 44470-38.**







**NEW**



**PC**

**Dome cover**

Campana  
Haube  
Cloche  
Campana

| art.     | Ø cm. | h. cm. |
|----------|-------|--------|
| 41413-30 | 30    | 40     |

**Fits to/Per art.: 44845-31, 44873-08, 44873-16, 44474-33, 44474-34.**



**NEW**

**W**



**Cake stand**

Alzata torta  
Tortenplatte  
Gueridon pâtissier  
Pedestal para tartas

| art.     | Ø cm. | h. cm. |
|----------|-------|--------|
| 44474-09 | 9,5   | 7      |
| 44474-13 | 13,0  | 9      |

**Acacia wood. – Legno d'acacia.**



**NEW**

**W**



**Cake stand**

Alzata torta  
Tortenplatte  
Gueridon pâtissier  
Pedestal para tartas

| art.     | Ø cm. | h. cm. | fits/per |
|----------|-------|--------|----------|
| 44474-24 | 24    | 8      | 41414-21 |
| 44474-33 | 33    | 8      | 41414-31 |
| 44474-38 | 38,5  | 8      | 41414-36 |

**Acacia wood. – Legno d'acacia.**



**NEW**

**W**



**Cake stand**

Alzata torta  
Tortenplatte  
Gueridon pâtissier  
Pedestal para tartas

| art.     | Ø cm. | h. cm. | fits/per |
|----------|-------|--------|----------|
| 44474-25 | 24    | 16     | 41414-21 |
| 44474-34 | 33    | 16     | 41413-30 |
| 44474-39 | 38,5  | 16     | 41414-36 |

**Acacia wood. – Legno d'acacia.**





**Cake stand**  
Alzata torta  
Tortenplatte  
Gueridon pâtissier  
Pedestal para tartas

| art.     | Ø cm.   | h. cm. |
|----------|---------|--------|
| 44475-80 | 11,5-15 | 10,5   |
| 44475-82 | 15-21   | 20,0   |



**Cake stand**  
Alzata torta  
Tortenplatte  
Gueridon pâtissier  
Pedestal para tartas

| art.     | Ø cm.   | h. cm. |
|----------|---------|--------|
| 44475-81 | 11,5-15 | 10,5   |
| 44475-83 | 21-15   | 20,0   |



**Tray with dome cover**  
Vassoio con campana  
Tablett mit Haube  
Plat avec cloche  
Bandeja con campana

| art.     | Ø cm. | h. cm. |
|----------|-------|--------|
| 41416-18 | 18,5  | 24,5   |

**Beech wood tray with glass cover Ø 16 H 22,5 cm.** – Vassoio in legno di faggio con coperchio in vetro Ø 16 H 22,5 cm.



**Display case**  
Vetrina brioches  
Vitrine für Brioches  
Vitrine brioches  
Vitrina brioches

| art.     | dim. cm. |
|----------|----------|
| 41472-32 | 37x31x31 |

**1 door, 3 shelves, H 10 cm.** – 1 porta, 3 piani H 10 cm.



**Showcase**  
Vetrina da banco  
Vitrine für Verkaufstheke  
Vitrine à comptoir  
Vitrina

| art.     | dim. cm.   |
|----------|------------|
| 47091-01 | 44x32x20,5 |

**Double side opening. Incl. s/s trays 39x28 cm, 4 coolers.** – Apertura doppio fronte. Con vassoio inox 39x28 cm, 2 eutettici.



**Showcase, 2-tier**  
Vetrina da banco, 2 piani  
Vitrine für Verkaufstheke, doppeldecker  
Vitrine à comptoir, 2 étages  
Vitrina, doble

| art.     | dim. cm. |
|----------|----------|
| 47091-02 | 44x32x44 |

**Double side opening. Incl. s/s tray 39x28 cm, 2 coolers.** – Apertura doppio fronte. Con vassoio inox 39x28 cm, 4 eutettici.



**Sweet box**  
Contentitore universale  
Universalbox  
Boîte à comptoir  
Exibidor

| art.     | dim. cm.   |
|----------|------------|
| 47090-23 | 23x14,5x15 |





**NEW**

**AY**

**Counter showcase**

Vetrina da banco  
Thekendisplay  
Vitrine de comptoir  
Vitrina de mostrador

| art.     | GN  | dim. cm. |
|----------|-----|----------|
| 41472-56 | 1/1 | 56x33x21 |

**With non-slip feet. Removable side panels.**  
Con piedini antiscivolo. Pannelli laterali removibili.



**NEW**

**AY**

**Counter showcase**

Vetrina da banco  
Thekendisplay  
Vitrine de comptoir  
Vitrina de mostrador

| art.     | dim. cm. | h. cm. |
|----------|----------|--------|
| 41472-55 | 56x20    | 21     |

**With non-slip feet. Removable side panels.**  
Con piedini antiscivolo. Pannelli laterali removibili.



**NEW**

**AY**

**Counter showcase**

Vetrina da banco  
Thekendisplay  
Vitrine de comptoir  
Vitrina de mostrador

| art.     | dim. cm. | h. cm. |
|----------|----------|--------|
| 41472-80 | 82,5x33  | 22,5   |
| 41472-99 | 102,5x33 | 25,5   |

**With non-slip feet. Removable side panels.**  
Con piedini antiscivolo. Pannelli laterali removibili.





# ICE CREAM GELATERIA

BAR HAPPY HOUR







SS

**Ice cream container**

Bacinella per gelato  
Eisbehälter  
Réceptient à glace  
Cubeta helado

| art.     | dim. cm. | lt. |
|----------|----------|-----|
| 41487-12 | 26x16x12 | 3,5 |
| 41487-15 | 26x16x15 | 4,1 |
| 41487-17 | 26x16x17 | 4,5 |



SS

**Ice cream container**

Bacinella per gelato  
Eisbehälter  
Réceptient à glace  
Cubeta helado

| art.     | dim. cm.   | lt. |
|----------|------------|-----|
| 41471-12 | 36x16,5x12 | 5,0 |
| 41471-15 | 36x16,5x15 | 6,5 |
| 41471-17 | 36x16,5x17 | 7,5 |



SS

**Ice cream container**

Bacinella per gelato  
Eisbehälter  
Réceptient à glace  
Cubeta helado

| art.     | dim. cm. | lt. |
|----------|----------|-----|
| 41486-08 | 36x25x8  | 5   |
| 41486-12 | 36x25x12 | 8   |
| 41486-15 | 36x25x15 | 10  |



PC

**Ice cream container**

Bacinella per gelato  
Eisbehälter  
Réceptient à glace  
Cubeta helado

| art.     | dim. cm.   | lt. |
|----------|------------|-----|
| 41431-12 | 36x16,5x12 | 5,4 |



PC

**Ice cream container**

Bacinella per gelato  
Eisbehälter  
Réceptient à glace  
Cubeta helado

| art.     | dim. cm. | lt. |
|----------|----------|-----|
| 41431-08 | 36x25x8  | 5,0 |



PMMA

**Lid for ice cream container**

Coperchio per bacinella gelato  
Deckel für Eisbehälter  
Couvercle pour réceptient à glace  
Tapa para cubeta helado

| art.     | dim. cm. |
|----------|----------|
| 41471-00 | 36x16,5  |



PC

**Lid for ice cream container**

Coperchio per bacinella gelato  
Deckel für Eisbehälter  
Couvercle pour réceptient à glace  
Tapa para cubeta helado

| art.     | dim. cm. |
|----------|----------|
| 41486-00 | 36x16,5  |
| 41486-01 | 36x25    |



SS

**Ice cream basin**

Carapina  
Eisbehälter  
Réceptient à glace  
Cubeta helado

| art.     | Ø cm. | h. cm. | lt. |
|----------|-------|--------|-----|
| 41489-20 | 20    | 25     | 7,3 |



SS

**Ice cream server**

Spatola gelato carapina  
Eisspachtel  
Palette à glace  
Paleta helados

| art.     | col. |
|----------|------|
| 41475-20 | ○    |



SS

**Ice cream server**

Spatola gelato  
Eisspachtel  
Palette à glace  
Paleta helados

| art.     | l. cm. | col. |
|----------|--------|------|
| 41475-00 | 27     | ○    |
| 41475-01 | 27     | ●    |
| 41475-03 | 27     | ●    |
| 41475-04 | 27     | ●    |
| 41475-05 | 27     | ●    |



**Ice-dipper**

Spatola gelato  
Eisdipper  
Cuillère à glace  
Cuchara helados

| art.     | Ø mm. | lt.  |
|----------|-------|------|
| 41468-20 | 55    | 1/20 |
| 41468-24 | 50    | 1/24 |

**With liquid heat conductor in the handle.**  
Con liquido conduttore nel manico.



**Ice-dipper**

Spatola gelato  
Eisdipper  
Cuillère à glace  
Cuchara helados

| art.     | Ø mm. | lt.  |
|----------|-------|------|
| 41469-20 | 55    | 1/20 |
| 41469-24 | 50    | 1/24 |

**With liquid heat conductor in the handle.**  
Con liquido conduttore nel manico.



SS

**Ice cream scoop**

Porzionatore  
Eisportionierer  
Cuillère à glace  
Racionador de helado

| art.     | Ø mm. | lt.  |
|----------|-------|------|
| 41476-50 | 50    | 1/24 |

**Non slip handle. – Manico antiscivolo.**



SS

**Ice cream scoop**

Porzionatore  
Eisportionierer  
Cuillère à glace  
Racionador de helado

| art.     | Ø mm. | lt.   |
|----------|-------|-------|
| 41473-31 | 30    | 1/100 |
| 41473-39 | 38    | 1/65  |
| 41473-44 | 43    | 1/50  |
| 41473-50 | 50    | 1/24  |
| 41473-56 | 55    | 1/20  |
| 41473-62 | 60    | 1/14  |
| 41473-66 | 66    | 1/12  |



**Ice cream scoop**

Porzionatore  
Eisportionierer  
Cuillère à glace  
Racionador de helado

| art.     | Ø mm. | lt.  |
|----------|-------|------|
| 41488-45 | 45    | 1/40 |
| 41488-47 | 47    | 1/36 |
| 41488-50 | 50    | 1/30 |
| 41488-53 | 53    | 1/24 |

**Nylon, fiberglass. Stainless steel mechanism.**  
Meccanismo in acciaio inox.



SS

**Oval ice cream scoop**

Porzionatore ovale  
Eisportionierer, oval  
Cuillère à glace ovale  
Racionador de helado oval

| art.     | Ø mm. | lt.  |
|----------|-------|------|
| 41474-00 | 60    | 1/30 |



SS

**Triangle ice cream scoop**

Porzionatore triangolare  
Eisportionierer, dreieckig  
Cuillère à glace triangle  
Racionador de helado triangular

| art.     | lt.  |
|----------|------|
| 41474-02 | 1/30 |



**Decorative scrapers 5 pcs**

Raschietti decorativi 5 pezzi  
Dekorative Schaber 5 Stk  
Raclettes décoratives 5 pcs  
Rasquetas decorativas 5 pz

| art.     | dim. cm. |
|----------|----------|
| 41472-43 | 14,5x15  |

**PETG.**



**Chalkmarker**

Penna a gesso liquido  
Kreidestifte  
Stylo à craie liquide  
Marcadores de tiza líquida

| art.     | col. |
|----------|------|
| 47832-01 | ●    |
| 47832-03 | ●    |
| 47832-04 | ●    |
| 47832-05 | ●    |

**Writes on all non porous surfaces. Clean with water. – Scrive su tutte le superfici non porose. Pulire con acqua.**



PMMA

**Flavour marker holder 10 pcs**

Porta segnagusto 10 pezzi  
Eisschilderhalter 10 Stk  
Porte-étiquettes 10 pièces  
Porta etiquetas 10 pz

| art.     | mm.   |
|----------|-------|
| 41472-46 | 87x52 |

**Labels not included. – Cartellino non incluso.**



PMMA

**Flavour marker 10 pcs**

Segnagusto 10 pezzi  
Eisschilder 10 Stk  
Étiquettes 10 pièces  
Etiquetas sabores 10 pz

| art.     | mm.    |
|----------|--------|
| 41472-44 | 190x85 |



PMMA

**Flavour marker**

Segnagusto  
Eisschilder  
Etiquette de saveur  
Etiqueta sabor

art. mm.  
41472-45 150x70



SS

**Counter ice cream cone holder**

Porta conì da banco  
Theke-Eiswaffelständer  
Porte cornets à glace de comptoir  
Expositor para cucuruchos

art. Ø cm. h. cm.  
41472-04 16,5 14



PMMA

**Counter ice cream cone holder**

Porta conì da banco  
Theke-Eiswaffelständer  
Porte cornets à glace de comptoir  
Expositor para cucuruchos

art. Ø mm. dim. cm.  
41472-07 3,5 21x8,5x11  
41472-08 3,5 28,5x8,5x11



SS

**Counter ice cream cone holder**

Porta conì da banco  
Theke-Eiswaffelständer  
Porte cornets à glace de comptoir  
Expositor para cucuruchos

art. dim. cm.  
41472-01 20x9,5x8,5



PMMA

**Paper napkins holder**

Porta tovaglioli  
Serviettenhalter  
Porte serviettes  
Porta servilletas

art. dim. cm.  
41472-12 18x6x10



PMMA

**Paper napkins holder**

Porta tovaglioli  
Serviettenhalter  
Porte serviettes  
Porta servilletas

art. dim. cm.  
41472-13 18x6x11



AY

PP

**Universal box**

Contentitore universale  
Universalbox  
Conteneur à comptoir  
Recipiente universal

art. dim. cm.  
47090-23 23x14,5x15



PMMA

**Box with lid**

Contentore con coperchio  
Behälter mit Deckel  
Boîte avec couvercle  
Recipiente con tapa

art. dim. cm.  
41472-25 27,5x10,5x9,5

**Compartments size 8,5x8 cm.**  
Dimensione scomparti 8,5x8 cm.



PMMA

**Box with lid**

Contentore con coperchio  
Behälter mit Deckel  
Boîte avec couvercle  
Recipiente con tapa

| art.     | Ø mm. | h. cm. |
|----------|-------|--------|
| 41472-26 | 10    | 15     |
| 41472-27 | 12    | 15     |
| 41472-28 | 15    | 15     |
| 41472-29 | 18    | 15     |



PMMA

**Waffle case**

Contentore per cialde  
Waffelbehälter  
Porte gaufres  
Dispensador waffles

art. dim. cm.  
41472-21 22x26x12



PMMA

**Spoon case**

Contentore per palette  
Eislöffelbehälter  
Porte cuillères à glace  
Dispensador cucharillas de helado

art. dim. cm.  
41472-20 19x12,5x14



PMMA

**Straws case**

Contentore per cannuccie  
Strohalmbehälter  
Porte chalumeaux  
Dispensador pajitas

art. dim. cm.  
41472-22 26x17x22



PMMA

**Cone holder, front opening**

Porta coni, apertura frontale  
Eiswaffelbehälter mit Frontöffnung  
Porte cornets à glace, ouverture frontale  
Porta cucuruchos, abertura frontal

art. dim. cm.  
41472-16 11x13x50



PMMA

**Spoon and cup holder**

Porta palette e coppette  
Eislöffel und Schalenbehälter  
Porte cuillères et pots  
Porta cucharillas y copas

art. dim. cm.  
41472-17 28x25x55



PMMA

**Cone holder 6 holes with spoon drawer**

Porta coni 6 fori c/porta palette  
Eiswaffelspender, 6 Löcher mit Palettenhalter  
Porte cornets 6 trous, porte cuillères  
Porta cucuruchos/cucharillas, 6 orificios

art. dim. cm.  
41472-18 25,5x18x60,5

**Upper hole Ø 3,5 cm. Lower Ø 2 cm. Distance between holes Ø 4,5 cm. Removable lower drawer.** – Foro superiore Ø 3,5 cm. Inferiore Ø 2 cm. Distanza tra i fori Ø 4,5 cm. Cassetto inferiore estraibile.



PMMA

**Cone holder 12 holes**

Porta coni 12 fori  
Eiswaffelspender, 12 Löcher  
Porte cornets 12 trous  
Porta cucuruchos 12 orificios

art. dim. cm.  
41472-24 33x25x50

**Upper hole Ø 5,2 cm. Lower Ø 2 cm.**  
Foro superiore Ø 5,2 cm. Inferiore Ø 2 cm.





PMMA

**Swivel cone holder 5 sections**

Porta coni rotante 5 sezioni  
Eiswaffelspender, drehbar, 5 Fächer  
Porte cornets rotatif, 5 comp  
Porta cucurucho giratorio 5 secciones

art. Ø cm. h. cm.

41472-23 25 50

**Upper hole Ø 3,5 cm. Lower Ø 2 cm. Distance between holes Ø 4,5 cm.** – Foro superiore Ø 3,5 cm. Inferiore Ø 2 cm. Distanza tra i fori Ø 4,5 cm.



PMMA

**Cone holder with door**

Porta coni con porta  
Eiswaffelspender mit Tür  
Porte cornets ouverture frontale  
Porta cucurucho, abertura frontal

art. dim. cm.

41472-19 33x18x50



PMMA

**Horizontal cone holder with door**

Porta coni orizzontale con porta  
Eiswaffelspender horizontal mit Tür  
Porte cornets à glace horizontal  
Porta cucurucho horizontal

art. Ø cm. dim. cm.

41472-14 30 42x37x40,5

**With removable divider.** – Con divisorio estraibile.



PMMA

**Revolving cones dispenser**

Porta coni girevole  
Eiswaffelspender, drehbar  
Porte-cornets pivotant  
Distributor giratorio de cucurucho

art. Ø cm. h. cm.

41472-15 24 78



MS

**Ice cream cup**

Coppa gelato  
Eisbecher  
Coupe à glace  
Copa helado

art. h. cm. lt. U. Pack

44942-12 6,5 0,26 6



MS

**Ice cream cup**

Coppa gelato  
Eisbecher  
Coupe à glace  
Copa helado

art. h. cm. lt. U. Pack

44942-11 11 0,38 6



MS

**Ice cream cup**

Coppa gelato  
Eisbecher  
Coupe à glace  
Copa helado

art. h. cm. lt. U. Pack

44942-10 16 0,25 6



SMMA

**Ice cream cup**

Coppa gelato  
Eisbecher  
Coupe à glace  
Copa helado

art. Ø cm. h. cm. U. Pack

44942-06 10 10 6



SMMA

**Ice cream cup**

Coppa gelato  
Eisbecher  
Coupe à glace  
Copa helado

art. Ø cm. h. cm. U. Pack

44942-07 9 19 6



MF

**Gourmet bowl**  
Ciotolina Gourmet  
Schälchen Gourmet  
Bol Gourmet  
Bol Gourmet

| art.     | Ø cm. | h. cm. | ml. |
|----------|-------|--------|-----|
| 44466-07 | 7     | 6      | 50  |



MF

**Gourmet tray**  
Vassoio Gourmet  
Tablett Gourmet  
Plateau Gourmet  
Bandeja Gourmet

| art.     | dim. cm.     |
|----------|--------------|
| 44466-30 | 30,5x9,5x2,5 |

COMPOSTABLE - COMPOSTABILI



An eco-friendly version of disposable items. Suitable both for pastry shops and events. Made of PLA, a revolutionary compostable and patented biopolymer that originates from plants and produced in a natural way.

Versione ecologica che rispetta l'ambiente. Realizzati in PLA, un rivoluzionario biopolimero compostabile e brevettato, derivato da piante e prodotto in modo naturale. Adatti sia nelle pasticcerie che per eventi.



**Glass**  
Bicchierino  
Glas  
Verrine  
Vaso

| art.     | Ø cm. | h. cm. | ml. |
|----------|-------|--------|-----|
| 48373-06 | 4,2   | 6,5    | 65  |
| 48373-09 | 5,0   | 6,5    | 90  |
| 48373-12 | 5,5   | 7,0    | 120 |
| 48373-17 | 6,0   | 9,0    | 170 |

Pcs/Conf. 100 pz.



NATURAL ELEGANT



A valid alternative to glass. Elegant and unbreakable ideals for HORECA pastry and ice cream sector. Made with high quality material that confers beside resistance also glossiness and perfect transparency. Bisphenol free. Thermal tolerance -18°C +70°C. 100% recyclable material. Dishwasher safe: up to 50 washes. Made in Italy.

La valida alternativa al vetro. Eleganti ed infrangibili ideali per il settore HORECA della pasticceria e gelateria. Realizzati con materiale di alta qualità che gli conferisce oltre alla resistenza anche lucidità e trasparenza. Privi di Bisfenolo. Tolleranza termica -18°C +70°C. Materiale riciclabile al 100%. Lavabili in lavastoviglie: fino a 50 lavaggi. Prodotti made in Italy.



**Bowl**  
Coppetta  
Schale  
Coupe  
Copa

| art.     | Ø cm. | h. cm. | ml. |
|----------|-------|--------|-----|
| 48367-10 | 7     | 5,9    | 105 |

Pcs/Conf. 100 pz.



**Glass**  
Bicchierino  
Glas  
Verrine  
Vaso

| art.     | dim. cm.      | ml. |
|----------|---------------|-----|
| 48371-10 | 7,3x6,4x5,2   | 100 |
| 48371-11 | lid/coperchio | -   |

Pcs/Conf. 100 pz.



**PS**

**Cup**  
Coppetta  
Schale  
Coupelle  
Bol

| art.     | Ø cm. | h. cm. | ml. |
|----------|-------|--------|-----|
| 48365-09 | 9     | 7,5    | 175 |

**Pcs/Conf. 100 pz.**



**Glass**  
Bicchierino  
Glas  
Verrine  
Vaso

| art.     | Ø cm.         | h. cm. | ml. |
|----------|---------------|--------|-----|
| 48370-10 | 7,8           | 5,7    | 210 |
| 48370-11 | lid/coperchio | -      | -   |

**Pcs/Conf. 100 pz.**



**PS**

**Cup**  
Coppetta  
Schale  
Coupelle  
Bol

| art.     | Ø cm. | h. cm. | ml. |
|----------|-------|--------|-----|
| 48366-09 | 9     | 7,5    | 125 |

**Pcs/Conf. 100 pz.**



**PS**

**Glass**  
Bicchierino  
Glas  
Verrine  
Vaso

| art.     | Ø cm. | h. cm. | ml. |
|----------|-------|--------|-----|
| 48354-01 | 4     | 8,5    | 70  |

**Pcs/Conf. 100 pz.**



**PS**

**Glass**  
Bicchierino  
Glas  
Verrine  
Vaso

| art.     | Ø cm. | h. cm. | ml. |
|----------|-------|--------|-----|
| 48350-01 | 4,2   | 6,5    | 50  |
| 48350-02 | 5,0   | 6,5    | 80  |
| 48350-03 | 5,5   | 7,0    | 100 |
| 48350-04 | 6,0   | 9,0    | 160 |

**Pcs/Conf. 100 pz.**



**PS**

**Glass**  
Bicchierino  
Glas  
Verrine  
Vaso

| art.     | Ø cm. | h. cm. | ml. |
|----------|-------|--------|-----|
| 48353-01 | 8,5   | 6,5    | 120 |

**Pcs/Conf. 100 pz.**





PS

Glass  
Bicchierino  
Glas  
Verrine  
Vaso

| art.     | dim. cm.  | ml. |
|----------|-----------|-----|
| 48351-01 | 4x4x5,5   | 50  |
| 48351-02 | 5x5x7     | 100 |
| 48351-03 | 5,5x5,5x8 | 150 |

Pcs/Conf. 100 pz.



PS

Glass  
Bicchierino  
Glas  
Verrine  
Vaso

| art.     | Ø cm. | h. cm. | ml. |
|----------|-------|--------|-----|
| 48352-01 | 6,5   | 5,5    | 70  |
| 48352-02 | 7,0   | 6,7    | 120 |
| 48352-03 | 7,5   | 7,3    | 150 |

Pcs/Conf. 100 pz.



Ice tube mold  
Stampo gelato  
Eisform  
Moule à glace  
Molde helado

| art.     | ml. |
|----------|-----|
| 41472-36 | 150 |

Pcs/Conf. 100 pz.



PMMA

Ice cream counter display  
Espositore per vetrina gelato  
Ständer für Eiscremetheke  
Présentoir de comptoir  
Expositor helados

| art.     | dim. cm.  | holes/fori |
|----------|-----------|------------|
| 41472-34 | 25x36x4,5 | 21         |
| 41472-35 | 16x36x4,5 | 15         |

For mold/Per stampo: 41472-36.



PMMA

Holder for blast chiller  
Supporto per abbattitore  
Ständer für Schnellabkühler  
Présentoir à cellule de refroidissement  
Soporte para abatidor

| art.     | dim. cm. | holes/fori |
|----------|----------|------------|
| 41472-33 | 29x39x12 | 28         |

For mold/Per stampo: 41472-36.







**Mini push up pops**

Stampi mini push up pops  
Mini push up pops Eisformen  
Moules à mini push up pops  
Mini push up pops moldes

| art.     | Ø cm. | h. cm. | ml. |
|----------|-------|--------|-----|
| 41472-37 | 4,0   | 18,8   | 90  |
| 41472-38 | 3,5   | 19,6   | 50  |

**Pcs/Conf. 100 pz.**



**PMMA**

**Ice cream counter display**

Espositore per vetrina gelato  
Ständer für Eiscremetheke  
Présentoir de comptoir  
Expositor helados

| art.     | dim. cm. | holes/fori |
|----------|----------|------------|
| 41472-39 | 25x36x4  | 21         |
| 41472-40 | 16x36x4  | 15         |

**For molds/Per stampi: 41472-37 - 41472-38.**



**PMMA**

**Display for mini ice cream cones**

Espositore per mini cornetti  
Waffelhörnchen-Ständer  
Présentoir à mini cornet à glace  
Expositor mini conos helado

| art.     | Ø cm. | dim. cm. | holes/fori |
|----------|-------|----------|------------|
| 41472-41 | 1,8   | 36x16,5  | 27         |
| 41472-42 | 1,8   | 36x25    | 45         |

**Suitable for all waffle minicones on the market.**  
Per tutti i miniconi in cialda in commercio.



**Ice cream mold, silicone**

Stampo gelato su stecco, silicone  
Eisform, Silikon  
Moule à glace, silicone  
Molde helado, silicona

| art.     | mm.      | ml. | pcs/pz |
|----------|----------|-----|--------|
| 41472-47 | 44x22x93 | 78  | 12     |

**Kit 2 molds of 6 pcs with white plastic tray and 50 pcs wooden sticks.** – Kit 2 stampi da 6 pz con vassoio in plastica e 50 bastoncini legno.



**PMMA**

**Ice cream counter display**

Espositore per vetrina gelato  
Ständer für Eiscremetheke  
Présentoir de comptoir  
Expositor helados

| art.     | dim. cm. | pcs/pz |
|----------|----------|--------|
| 41472-48 | 36x25x5  | 24     |

**For mold/Per stampo: 41472-47.**



**Tray with cover**

Vassoio con coperchio  
Tablett mit Deckel  
Plateau avec couvercle  
Bandeja con tapa Cm 59X39X8

| art.     | dim. cm. |
|----------|----------|
| 41472-50 | 59x39x8  |

**Unbreakable, shock resistant even at very low temperatures.** – Infrangibile, resistente agli urti anche a bassissime temperature.



**ABS**

**Tempering unit**

Temperatrice  
Temperiergerät  
Tempereuse  
Templadora

| art.     | Ø cm. | h. cm. | lt. |
|----------|-------|--------|-----|
| 47698-01 | 20,5  | 21,2   | 1,7 |

**Ideal for chocolate coatings of ice creams on sticks. Removable anodized aluminum tank.**  
Ideale per coperture in cioccolato di gelati e semifreddi su stecco. Vasca estraibile in alluminio anodizzato.



ABS

**Tempering unit**

Temperatrice  
Temperiergerät  
Tempereuse  
Templadora

| art.     | Ø cm. | h. cm. | lt. |
|----------|-------|--------|-----|
| 47698-02 | 26    | 16     | 1,8 |

**Allows to process tiny chocolate quantities without any waste. Removable tank.**

Adatto per piccole produzioni senza sprechi.  
Pratica vasca estraibile.



KAYSER SS

**Professional cream whipper**

Sifone panna professionale  
Profi-Sahnebereiter  
Siphon à crème professionnel  
Sifón montador de nata profesional

| art.     | lt. |
|----------|-----|
| 41451-05 | 0,5 |
| 41451-10 | 1,0 |



**Cream chargers, 10-pcs set**

Ricariche panna montata, conf. 10 pezzi  
10-Stk. Sahnekapseln-Packung  
Capsules à crème Chantilly, set 10 pièces  
Cápsulas para nata, 10 piezas

| art.     |
|----------|
| 41450-AA |

**Contains N2O under pressure.**  
Contiene N2O sotto pressione.



SS

**GOURMET-Cream whipper**

Sifone panna  
Sahnebereiter  
Siphon à crème  
Sifón para nata montada

| art.     | lt.  |
|----------|------|
| 41458-02 | 0,25 |
| 41458-05 | 0,50 |
| 41458-10 | 1,00 |

**Heat resistant silicone gasket. Keep warm in bain marie up to 75°C.**

Guarnizione in silicone resistente al calore. Tenere a bagnomaria max. a 75°C.



SS

**THERMO-Cream whipper**

Sifone termico  
Thermo-Sahnebereiter  
Siphon à crème, isotherme  
Sifón isotérmico

| art.     | lt. |
|----------|-----|
| 41455T55 | 0,5 |

**Double-walled, insulated bottle: keeps creations cold for 8 hours and hot for 3 hours, dishwasher-safe. – Bottiglia termica, mantiene le preparazioni in caldo fino a 3 ore e a freddo fino a 8 ore.**



SS

**THERMO SPRESS-Cream whipper**

Sifone termico  
Thermo-Sahnebereiter  
Siphon à crème, isotherme  
Sifón isotérmico

| art.     | h. cm. | lt. |
|----------|--------|-----|
| 41459-10 | 35     | 1   |

**Double-walled, insulated bottle, keeps creations cold for 8 hours and hot for 3 hours. – Bottiglia termica, mantiene le preparazioni in caldo fino a 3 ore e a freddo fino a 8 ore, lavabile in lavastoviglie.**



SS

**PROFI-Cream whipper**

Sifone panna  
Sahnebereiter  
Siphon à crème  
Sifón para nata montada

| art.     | lt. |
|----------|-----|
| 41460-05 | 0,5 |
| 41460-10 | 1,0 |

**Only for cold preparations.**  
Solo per preparazioni fredde.



iSi

**Decorating tips, 3-pcs set**

Bocchette, set 3 pezzi  
Dekorationstüllen, 3er Set  
Douilles de décoration, 3 pièces  
Boquillas de decoración, 3 piezas

| art.     |
|----------|
| 41455-BC |



iSi

**Decorating tips, 3-pcs set**

Bocchette, set 3 pezzi  
Dekorationstüllen, 3er Set  
Douilles de décoration, 3 pièces  
Boquillas de decoración, 3 piezas

| art.     |
|----------|
| 41458-23 |

SS



**Decorating tips and adapter**

Bocchette decoro e adattatore  
Dekorationstüllen-Set u. Adapter  
Douilles de décoration et adaptateur  
Boquillas de decoración y adaptador

art. 41458-24



**Injector needles**

Iniettori/siringhe decoro  
Nadeltüllen  
Aiguilles d'injection  
Boquillas de aguja

art. 41458-21



**Heat protector, silicone**

Protezione in silicone  
Silikonhülle  
Housse en silicone  
Protección de silicona

| art.     | lt. |
|----------|-----|
| 41458-50 | 0,5 |
| 41458-51 | 1,0 |



**Cream chargers, PROFESSIONAL**

Ricariche panna montata, PROFESSIONAL  
Sahnekapself-Packung, PROFESSIONAL  
Capsules à crème Chantilly, PROFESSIONAL  
Cápsulas para nata, PROFESSIONAL

| art.     | pcs/pz |
|----------|--------|
| 41455-CA | 24     |
| 41455-CB | 50     |

**Filled with 8,4 g of N2O (E942, nitrous oxide).**  
Contenuto: 8,4 g di N2O (E942 protossido di azoto).



**Funnel and sieve**

Imbuto e colino  
Trichter und Sieb  
Entonnoir et tamis  
Embudo y tamiz

art. 41458-11



**Kit rapid infusion**

Kit di infusione rapida  
Rapid Infusion Set  
Paquet rapid infusion  
Rapid infusion set

art. 41458-25

**Enables a liquid to be infused with different flavors in the shortest possible time. First, combine aromatic solids (e.g. herbs, spices, fruit) and a liquid (e.g. alcohol, oil, water, vinegar) in the whipper then apply pressure into it using a cream charger.** – Permette di infondere un liquido con sapori diversi in tempo rapido. Unire gli aromi solidi (erbe, spezie, frutta, ecc.) con il liquido (alcol, olio, acqua, aceto, ecc.) nel sifone ed immettere una carica per panna.





# COCKTAIL BAR

BAR HAPPY HOUR

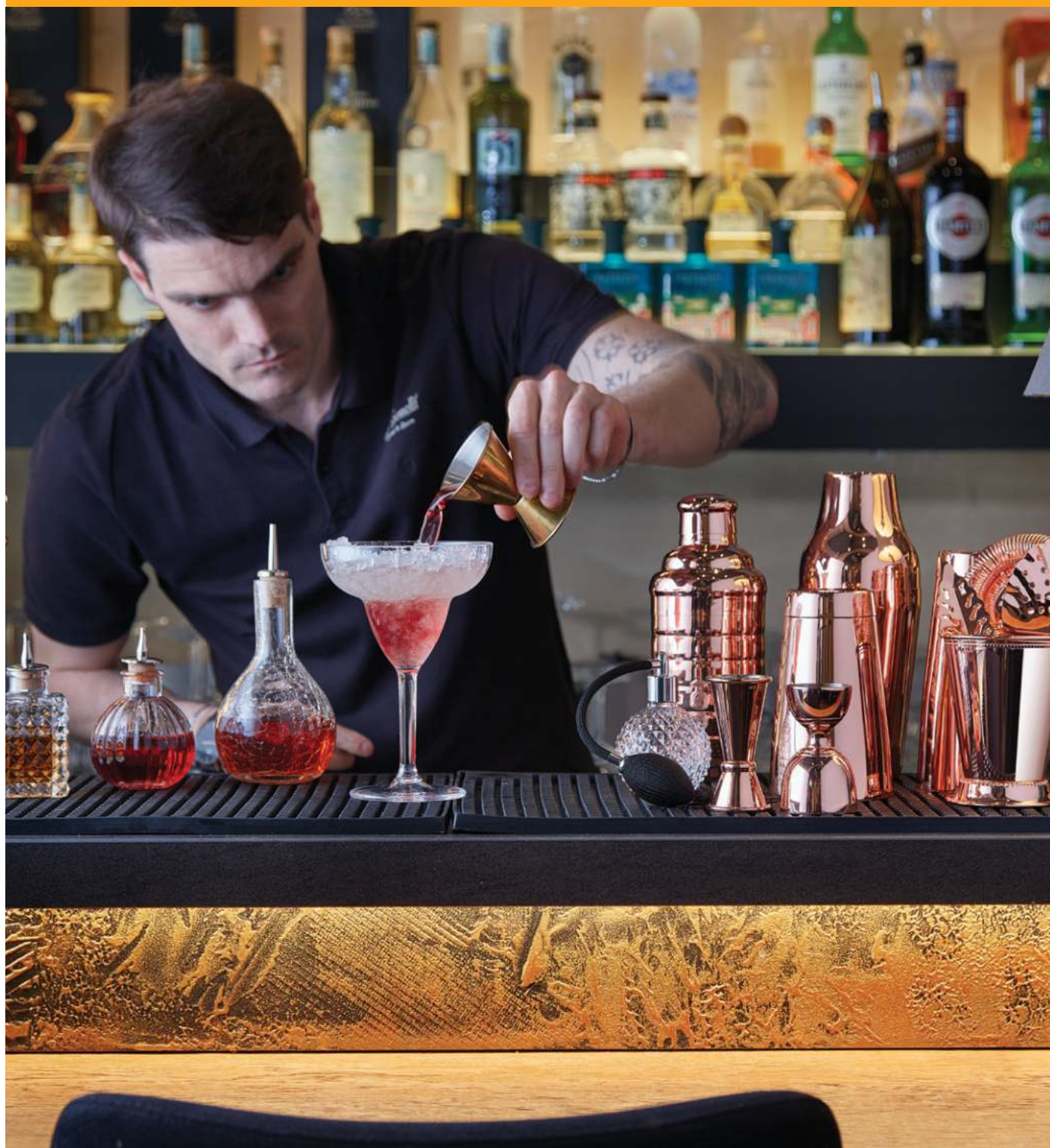

Paderno offers a wide selection of bar equipment, designed to combine easy use with efficiency and style. The tools are flanked by fascinating accessories making every moment trendy and lively. To share refined happy hours, to enjoy spectacular cocktails and long drinks, or to add style to every sort of drink.

Paderno propone un'ampia selezione di attrezzature bar, ideata per unire praticità d'utilizzo a efficienza e stile. Agli utensili si affiancano affascinanti accessori in grado di rendere trendy e vivace ogni momento. Per condividere raffinati happy hour, per gustare scenografici cocktail e long drink, oppure per aggiungere stile a ogni tipo di bevanda.







SS

**Pumpkin mug**

Coppa zucca  
Kürbis-Becher  
Gobelet citrouille  
Vaso de calabaza

| art.     | Ø cm. | h. cm. | ml. | col. |
|----------|-------|--------|-----|------|
| 44944G07 | 10    | 14,5   | 700 | ●    |
| 44944C07 | 10    | 14,5   | 700 | ●    |



SS

**Pineapple cup**

Coppa ananas  
Ananas-Becher  
Gobelet ananas  
Vaso de piña

| art.     | Ø cm. | h. cm. | ml. | col. |
|----------|-------|--------|-----|------|
| 44945G05 | 9,5   | 20,5   | 500 | ●    |
| 44945C05 | 9,5   | 20,5   | 500 | ●    |

With straw. – Con cannuccia.



SS

**Champagne glass**

Flute champagne  
Champagner Glas  
Verre champagne  
Copa champán

| art.     | Ø cm. | h. cm. | ml. | col. |
|----------|-------|--------|-----|------|
| 41493G00 | 5     | 25,5   | 270 | ●    |
| 41493C00 | 5     | 25,5   | 270 | ●    |
| 41493B00 | 5     | 25,5   | 270 | ●    |



SS

**Martini cup**

Coppa martini  
Martini Cocktail Glas  
Verre à martini  
Copa martini

| art.     | Ø cm. | h. cm. | ml. | col. |
|----------|-------|--------|-----|------|
| 41494G00 | 12    | 16,5   | 200 | ●    |
| 41494C00 | 12    | 16,5   | 200 | ●    |
| 41494B00 | 12    | 16,5   | 200 | ●    |



SS

**Margarita cup**

Coppa margarita  
Margarita Cocktail Glas  
Verre à margarita  
Copa margarita

| art.     | Ø cm. | h. cm. | ml. | col. |
|----------|-------|--------|-----|------|
| 41498G00 | 10,5  | 14     | 220 | ●    |
| 41498C00 | 10,5  | 14     | 220 | ●    |
| 41498B00 | 10,5  | 14     | 220 | ●    |



SS

**Moscow mule mug**

Tazza moscow mule  
Moscow Mule Becher  
Gobelet moscow mule  
Taza moscow mule

| art.     | Ø cm. | h. cm. | ml. | col. |
|----------|-------|--------|-----|------|
| 41463-01 | 8,9   | 9      | 500 | ●    |



SS

**Moscow mule mug**  
Tazza moscow mule  
Moscow Mule Becher  
Gobelet moscow mule  
Taza moscow mule

| art.     | Ø cm. | h. cm. | ml. | col. |
|----------|-------|--------|-----|------|
| 41463-02 | 8,5   | 9,7    | 500 | ●    |

Gold plated handle. – Manico dorato.



SS

**Moscow mule mug, antique**  
Tazza moscow mule, antique  
Moscow Mule Becher, Antik  
Gobelet moscow mule, antique  
Taza moscow mule, antiguo

| art.     | Ø cm. | h. cm. | ml. | col. |
|----------|-------|--------|-----|------|
| 41463A05 | 8,5   | 9,7    | 500 | ●    |

Gold plated handle. – Manico dorato.



SS

**Moscow mule mug**  
Tazza moscow mule  
Moscow Mule Becher  
Gobelet moscow mule  
Taza moscow mule

| art.     | Ø cm. | h. cm. | ml. | col. |
|----------|-------|--------|-----|------|
| 41463G05 | 8,5   | 9,7    | 500 | ●    |

Gold plated handle. – Manico dorato.



SS

**Moscow mule mug**  
Tazza moscow mule  
Moscow Mule Becher  
Gobelet moscow mule  
Taza moscow mule

| art.     | Ø cm. | h. cm. | ml. | col. |
|----------|-------|--------|-----|------|
| 41463B05 | 8,5   | 9,7    | 500 | ●    |

Gold plated handle. – Manico dorato.



SS

**Moscow mule mug**  
Tazza moscow mule  
Moscow Mule Becher  
Gobelet moscow mule  
Taza moscow mule

| art.     | Ø cm. | h. cm. | ml. |
|----------|-------|--------|-----|
| 41463M05 | 8,5   | 10     | 550 |

Water transfer printing. Gold plated handle.  
Stampa a trasferimento ad acqua. Manico dorato.



SS

**Moscow mule mug**  
Tazza moscow mule  
Becher Moscow Mule  
Gobelet moscow mule  
Taza moscow mule

| art.     | Ø cm. | h. cm. | lt. | col. |
|----------|-------|--------|-----|------|
| 41463C30 | 15,5  | 17,5   | 3   | ●    |
| 41463C50 | 18,0  | 20,0   | 5   | ●    |

Gold plated handle. – Manico dorato.



SS

**Moscow mule mug, antique**  
Tazza moscow mule, antique  
Becher Moscow Mule, Antik  
Gobelet moscow mule, antique  
Taza moscow mule, antiguo

| art.     | Ø cm. | h. cm. | lt. | col. |
|----------|-------|--------|-----|------|
| 41463A30 | 15,5  | 17,5   | 3   | ●    |
| 41463A50 | 18,0  | 20,0   | 5   | ●    |

Gold plated handle. – Manico dorato.







SS

**Mini moscow mule mug**  
Mini moscow mule  
Moscow Mule Shotbecher  
Moscow mule à shot  
Chupito moscow mule

| art.     | Ø cm. | h. cm. | ml. | col. |
|----------|-------|--------|-----|------|
| 41463C00 | 4,6   | 4,7    | 60  | ●    |

**Gold plated handle. Set 4 pcs. – Manico dorato. Conf. 4 pz.**



SS

**Mini moscow mule mug, antique**  
Mini moscow mule, antique  
Moscow Mule Shotbecher, Antik  
Moscow mule à shot, antique  
Chupito moscow mule, antiguo

| art.     | Ø cm. | h. cm. | ml. | col. |
|----------|-------|--------|-----|------|
| 41463A00 | 4,6   | 4,7    | 60  | ●    |

**Gold plated handle. Set 4 pcs. – Manico dorato. Conf. 4 pz.**



SS

**Cola cup**  
Tazza Cola  
Cola-Becher  
Gobelet Cola  
Taza Cola

| art.     | Ø cm. | h. cm. | ml. | col. |
|----------|-------|--------|-----|------|
| 44941G05 | 7,5   | 11     | 490 | ●    |
| 44941C05 | 7,5   | 11     | 490 | ●    |
| 44941B05 | 7,5   | 11     | 490 | ●    |



SS

**Mint julep cup**  
Coppa mint julep  
Becher für Mint Julep  
Tasse à cocktail mint julep  
Vaso para mint julep

| art.     | Ø cm. | h. cm. | ml. | col. |
|----------|-------|--------|-----|------|
| 41497-05 | 8,5   | 10,5   | 380 | ●    |
| 41497G05 | 8,5   | 10,5   | 380 | ●    |
| 41497C05 | 8,5   | 10,5   | 380 | ●    |
| 41497B05 | 8,5   | 10,5   | 380 | ●    |



SS

**Julep mug**  
Tazza julep  
Becher Julep  
Gobelet julep  
Taza julep

| art.     | Ø cm. | h. cm. | ml. | col. |
|----------|-------|--------|-----|------|
| 41470C03 | 8     | 12     | 335 | ●    |



SS

**Julep mug, antique**  
Tazza julep, antique  
Becher Julep, Antik  
Gobelet julep, antique  
Taza julep, antiguo

| art.     | Ø cm. | h. cm. | ml. | col. |
|----------|-------|--------|-----|------|
| 41470A03 | 8     | 12     | 335 | ●    |



SS

**Mini mug**  
Mini tazza  
Shotbecher  
Verre à shot  
Vaso de chupito

| art.     | Ø cm. | h. cm. | ml. | col. |
|----------|-------|--------|-----|------|
| 41470C00 | 4,5   | 5,5    | 60  | ●    |

Set 4 pcs. – Conf. 4 pz.



SS

**Mini mug, antique**  
Mini tazza, antique  
Shotbecher, Antik  
Verre à shot, antique  
Vaso de chupito, antiguo

| art.     | Ø cm. | h. cm. | ml. | col. |
|----------|-------|--------|-----|------|
| 41470A00 | 4,5   | 5,5    | 60  | ●    |

Set 4 pcs. – Conf. 4 pz.



**Tiki skull glass**  
Tiki mug teschio in vetro  
Tiki-Schädelglas  
Tiki mug crâne en verre  
Vaso Tiki de vidrio

| art.     | Ø cm. | h. cm. | ml. |
|----------|-------|--------|-----|
| 44948-07 | 13    | 10,5   | 700 |



**Tiki mug ceramic**  
Tiki mug in ceramica  
Tiki-Becher aus Keramik  
Tiki mug en céramique  
Taza Tiki en cerámica

| art.     | h. cm. | ml. |
|----------|--------|-----|
| 44949-02 | 22     | 500 |





**Tiki mug ceramic**

Tiki mug in ceramica  
Tiki-Becher aus Keramik  
Tiki mug en céramique  
Taza Tiki en cerámica

| art.     | Ø cm. | h. cm. | ml. |
|----------|-------|--------|-----|
| 44949-01 | 9,3   | 11     | 450 |



**Tiki mug ceramic**

Tiki mug in ceramica  
Tiki-Becher aus Keramik  
Tiki mug en céramique  
Taza Tiki en cerámica

| art.     | Ø cm. | h. cm. | ml. |
|----------|-------|--------|-----|
| 44949-03 | 7     | 21,5   | 650 |



**Tiki mug ceramic**

Tiki mug in ceramica  
Tiki-Becher aus Keramik  
Tiki mug en céramique  
Taza Tiki en cerámica

| art.     | h. cm. | ml. |
|----------|--------|-----|
| 44949-04 | 15     | 550 |



**Tiki mug ceramic**

Tiki mug in ceramica  
Tiki-Becher aus Keramik  
Tiki mug en céramique  
Taza Tiki en cerámica

| art.     | Ø cm. | h. cm. | ml. |
|----------|-------|--------|-----|
| 44949-05 | 8     | 16,5   | 340 |



**Tiki mug ceramic**

Tiki mug in ceramica  
Tiki-Becher aus Keramik  
Tiki mug en céramique  
Taza Tiki en cerámica

| art.     | Ø cm. | h. cm. | ml. |
|----------|-------|--------|-----|
| 44949-06 | 8     | 17     | 510 |



**PVD**

**SS**

**Straight straws**

Cannucce  
Strohhalme  
Pailles  
Pajitas

| art.     | Ø mm. | l. cm. | col. |
|----------|-------|--------|------|
| 41490-00 | 6     | 21,5   | ●    |
| 41490B00 | 6     | 21,5   | ●    |
| 41490G00 | 6     | 21,5   | ●    |
| 41490C00 | 6     | 21,5   | ●    |

**Set 12 pcs plus 1 straw brush.**

Conf. 12 pz + 1 scovolino.



**PVD**

**SS**

**Curved straws**

Cannucce curve  
Gebogene Strohhalme  
Pailles incurvées  
Pajitas curvados

| art.     | Ø mm. | l. cm. | col. |
|----------|-------|--------|------|
| 41490-01 | 6     | 21,5   | ●    |
| 41490B01 | 6     | 21,5   | ●    |
| 41490G01 | 6     | 21,5   | ●    |
| 41490C01 | 6     | 21,5   | ●    |

**Set 12 pcs plus 1 straw brush.**

Conf. 12 pz + 1 scovolino.



**SS**

**Straw brush, 5 pcs**

Scovolini, 5 pezzi  
Strohhalme-Bürste, 5 Stk.  
Brosses à pailles, 5 pièces  
Cepillos para pajitas, 5 pz

| art.     | l. cm. |
|----------|--------|
| 41490-AA | 21     |



B

**Straight straws, 24 pcs**

Cannucce, 24 pz  
Strohhalme, 24 Stk  
Pailles, 24 pièces  
Pajitas, 24 piezas

| art.     | Ø mm. | l.  |
|----------|-------|-----|
| 48310-14 | 5-7   | 140 |
| 48310-20 | 5-7   | 200 |



B

**Straight straws, 150 pcs**

Cannucce, 150 pz  
Strohhalme, 150 Stk  
Pailles, 150 pièces  
Pajitas, 150 piezas

| art.     | Ø mm. | l.  |
|----------|-------|-----|
| 48311-20 | 6-8   | 200 |
| 48311-25 | 6-8   | 250 |



B

**Straight straws, 110 pcs**

Cannucce, 110 pz  
Strohhalme, 110 Stk  
Pailles, 110 pièces  
Pajitas, 110 piezas

| art.     | Ø mm. | l.  |
|----------|-------|-----|
| 48312-25 | 9-10  | 250 |



B

**Straight straws, 24 pcs**

Cannucce, 24 pz  
Strohhalme, 24 Stk  
Pailles, 24 pièces  
Pajitas, 24 piezas

| art.     | Ø mm. | l.  |
|----------|-------|-----|
| 48313-14 | 10-12 | 140 |
| 48313-18 | 10-12 | 180 |
| 48313-20 | 10-12 | 200 |



**3 Straight straws, 3 bent, glass**

3 Cannucce diritte, 3 curve in vetro  
3 Gerade Strohhalme, 3 gebogene aus Glas  
3 Pailles droites, 3 incurvées en verre  
3 Pajitas eectas, 3 curvados de vidrio

| art.     | Ø mm. | l.  |
|----------|-------|-----|
| 41495-08 | 8     | 215 |
| 41495-10 | 10    | 215 |

Incl. 2 straw brushes. – Incl. 2 scovolini.



SS

**Drinks stirrers flamingo, 4 pcs**

Miscelatori cocktail fenicottero, 4 pz  
Flamingo-Cocktail Rührer, 4 Stk  
Agitateurs cocktails flamant, 4 pcs  
Agitadores cócteles flamingo, 4 pz

| art.     | l. cm. | col. |
|----------|--------|------|
| 41491G00 | 21,5   | ●    |
| 41491C00 | 21,5   | ●    |



SS

**Drinks stirrers skull, 4 pcs**

Miscelatori cocktail teschio, 4 pz  
Totenkopf-Cocktail Rührer, 4 Stk  
Agitateurs tête de mort, 4 pcs  
Agitadores cócteles cráneo, 4 pz

| art.     | l. cm. | col. |
|----------|--------|------|
| 41491G01 | 18,5   | ●    |
| 41491C01 | 18,5   | ●    |



SS

**Drinks stirrers pineapple, 4 pcs**

Miscelatori cocktail ananas, 4 pz  
Ananas-Cocktail Rührer, 4 Stk  
Agitateurs cocktails ananas, 4 pcs  
Agitadores cócteles piña, 4 pz

| art.     | l. cm. | col. |
|----------|--------|------|
| 41491G02 | 20     | ●    |
| 41491C02 | 20     | ●    |



SS

**Drinks stirrers owl, 4 pcs**

Miscelatori cocktail gufo, 4 pz  
Eule-Cocktail Rührer, 4 Stk  
Agitateurs cocktails hibou, 4 pcs  
Agitadores cócteles búho, 4 pz

| art.     | l. cm. | col. |
|----------|--------|------|
| 41491G03 | 20     | ●    |
| 41491C03 | 20     | ●    |



SS

**Drinks stirrers seahorse, 4 pcs**

Miscelatori cavalluccio marino, 4 pz  
Seepferdchen-Cocktail Rührer, 4 Stk  
Agitateurs hippocampe, 4 pcs  
Agitadores caballo de mar, 4 pz

| art.     | l. cm. | col. |
|----------|--------|------|
| 41491G04 | 20,5   | ●    |
| 41491C04 | 20,5   | ●    |



SS

**Drinks stirrers bow-knot, 4 pcs**

Miscelatori cocktail fiocco, 4 pz  
Bogenknoten-Cocktail Rührer, 4 Stk  
Agitateurs noeud d'arc, 4 pcs  
Agitadores nudo de proa, 4 pz

| art.     | l. cm. | col. |
|----------|--------|------|
| 41491G05 | 21     | ●    |
| 41491C05 | 21     | ●    |



SS

**Drinks stirrers octopus, 4 pcs**

Miscelatori cocktail polipo, 4 pz  
Tintenfisch-Cocktail Rührer, 4 Stk  
Agitateurs cocktails poulpe, 4 pcs  
Agitadores cócteles pulpo, 4 pz

| art.     | l. cm. | col. |
|----------|--------|------|
| 41491G06 | 18,5   | ●    |
| 41491C06 | 18,5   | ●    |



SS

**Tweezer**

Pinza  
Zange  
Pince  
Pinza

| art.     | l. cm. | col. |
|----------|--------|------|
| 42902-30 | 30     | ●    |
| 42902G30 | 30     | ●    |



SS

**Tweezer**

Pinza  
Zange  
Pince  
Pinza

| art.     | l. cm. | col. |
|----------|--------|------|
| 42902C30 | 30     | ●    |
| 42902B30 | 30     | ●    |



SS

**Tweezer**

Pinza  
Zange  
Pince  
Pinza

| art.     | l. cm. |
|----------|--------|
| 42902-31 | 30     |



SS

**Cocktail spoon**

Cucchiaio miscelatore  
Cocktail-Löffel  
Cuillère à cocktail  
Cuchara cóctel

| art.     | l. cm. |
|----------|--------|
| 41605-00 | 27     |



SS

**Cocktail spoon**

Cucchiaio miscelatore  
Cocktail-Löffel  
Cuillère à cocktail  
Cuchara cóctel

| art.     | l. cm. | col. |
|----------|--------|------|
| 41605-01 | 28     | ●    |



SS

**Cocktail spoon**

Cucchiaio miscelatore  
Cocktail-Löffel  
Cuillère à cocktail  
Cuchara cóctel

| art.     | l. cm. | col. |
|----------|--------|------|
| 41605G27 | 28     | ●    |
| 41605B27 | 28     | ●    |



SS

**Cocktail spoon/fork**

Cucchiaio/forchetta miscelatore  
Cocktail-Löffell/-Gabel  
Cuillère/fourchette à cocktail  
Cuchara/tenedor cóctel

| art.     | l. cm. | col. |
|----------|--------|------|
| 41605-03 | 50     | ●    |
| 41605G03 | 50     | ●    |



SS

**Cocktail spoon/fork**

Cucchiaio/forchetta miscelatore  
Cocktail-Löffell/-Gabel  
Cuillère/fourchette à cocktail  
Cuchara/tenedor cóctel

| art.     | l. cm. | col. |
|----------|--------|------|
| 41605C03 | 50     | ●    |
| 41605B03 | 50     | ●    |



SS

**Absinthe spoon**  
Cucchiaio assenzio  
Absinth-Löffel  
Cuillère d'absinthe  
Cuchara de ajenjo

| art.     | l. cm. | col. |
|----------|--------|------|
| 41600-00 | 16     | ●    |
| 41600G00 | 16     | ●    |
| 41600C00 | 16     | ●    |



SS

**Magic spoon whisks**  
Cucchiaio magico  
Zauberlöffel  
Fouet plat à spirales  
Cuchara mágica

| art.     | l. cm. |
|----------|--------|
| 41595-20 | 20     |



SS

**Strainer**  
Colino  
Sieb  
Passoire  
Colador

| art.     | Ø cm. | col. |
|----------|-------|------|
| 41570-10 | 10    | ●    |
| 41570G10 | 10    | ●    |



SS

**Strainer**  
Colino  
Sieb  
Passoire  
Colador

| art.     | Ø cm. | col. |
|----------|-------|------|
| 41570C10 | 10    | ●    |
| 41570B10 | 10    | ●    |



SS

**Cocktail strainer**  
Colino cocktail  
Cocktail-Sieb  
Passoire à cocktail  
Colador cóctel

| art.     | Ø cm. | col. |
|----------|-------|------|
| 41603-00 | 9     | ●    |
| 41603G00 | 9     | ●    |



SS

**Cocktail strainer**  
Colino cocktail  
Cocktail-Sieb  
Passoire à cocktail  
Colador cóctel

| art.     | Ø cm. | col. |
|----------|-------|------|
| 41603C00 | 9     | ●    |
| 41603B00 | 9     | ●    |



SS

**Julep strainer**  
Colino Julep  
Julep Barsieb  
Tamis cocktail Julep  
Colador de cóctel

| art.     | Ø cm. | col. |
|----------|-------|------|
| 41603-07 | 7,5   | ●    |
| 41603G07 | 7,5   | ●    |



SS

**Julep strainer**  
Colino Julep  
Julep Barsieb  
Tamis cocktail Julep  
Colador de cóctel

| art.     | Ø cm. | col. |
|----------|-------|------|
| 41603C07 | 7,5   | ●    |
| 41603B07 | 7,5   | ●    |



SS

**Cocktail measuring cup**  
Misurino cocktail  
Alkohol-Meßbecher  
Mesureur de cocktail  
Medidor de cóctel

| art.     | ml. |
|----------|-----|
| 41609-75 | 75  |



SS

**Cocktail jigger**  
Misurino cocktail  
Cocktail-Doppelmaß  
Mesureur de cocktail  
Medidor de cóctel

| art.     | ml.   | col. |
|----------|-------|------|
| 41609-36 | 30/60 | ●    |
| 41609G36 | 30/60 | ●    |
| 41609C36 | 30/60 | ●    |
| 41609B36 | 30/60 | ●    |



SS

**Cocktail jigger**  
Misurino cocktail  
Cocktail-Doppelmaß  
Mesureur de cocktail  
Medidor de cóctel

| art.     | ml.   | col. |
|----------|-------|------|
| 41604-00 | 20/40 | ●    |
| 41604G00 | 20/40 | ●    |
| 41604C00 | 20/40 | ●    |
| 41604B00 | 20/40 | ●    |





SS

**Japanese jigger**

Misurino cocktail Giapponese  
Japanischer Messbecher  
Mesureur de cocktail Japonais  
Medidor de cóctel Japonés

art. ml. col.

|          |       |   |
|----------|-------|---|
| 41604-01 | 20/40 | ● |
| 41604G01 | 20/40 | ● |
| 41604C01 | 20/40 | ● |
| 41604B01 | 20/40 | ● |



SS

**Long-drink shaker**

Shaker  
Shaker  
Shaker  
Coctelera

art. Ø cm. h. cm. ml. col.

|          |     |      |     |   |
|----------|-----|------|-----|---|
| 41484-05 | 8,8 | 20,5 | 500 | ● |
| 41484G05 | 8,8 | 20,5 | 500 | ● |
| 41484C05 | 8,8 | 20,5 | 500 | ● |
| 41484B05 | 8,8 | 20,5 | 500 | ● |



SS

**Long-drink shaker**

Shaker  
Shaker  
Shaker  
Coctelera

art. ml.

|          |     |
|----------|-----|
| 41480-03 | 200 |
| 41480-05 | 500 |
| 41480-07 | 700 |



SS

SAN

**Long-drink shaker**

Shaker  
Shaker  
Shaker  
Coctelera

art. ml. col.

|          |     |   |
|----------|-----|---|
| 41481-02 | 550 | ● |
| 41481-03 | 550 | ● |



AY

**Long-drink shaker**

Shaker  
Shaker  
Shaker  
Coctelera

art. ml.

|          |     |
|----------|-----|
| 41483-04 | 420 |
| 41483-06 | 660 |



SS

**Long-drink shaker**

Shaker  
Shaker  
Shaker

Coctelera

| art.     | Ø cm. | h. cm. | ml. | col. |
|----------|-------|--------|-----|------|
| 41480G05 | 8,7   | 20,5   | 500 | ●    |
| 41480C05 | 8,7   | 20,5   | 500 | ●    |
| 41480B05 | 8,7   | 20,5   | 500 | ●    |



SS

**Shaker parisienne**

Shaker parisienne  
Shaker parisienne  
Shaker parisienne

Coctelera parisienne

| art.     | Ø cm. | h. cm. | ml. | col. |
|----------|-------|--------|-----|------|
| 41461-07 | 9     | 23     | 700 | ●    |
| 41461G07 | 9     | 23     | 700 | ●    |
| 41461C07 | 9     | 23     | 700 | ●    |
| 41461B07 | 9     | 23     | 700 | ●    |



SS

**Shaker calabrese**

Shaker calabrese  
Shaker Calabrese  
Shaker calabrese  
Coctelera calabrese

| art.     | Ø cm. | h. cm. | ml. | col. |
|----------|-------|--------|-----|------|
| 41464-09 | 9,5   | 24,5   | 900 | ●    |
| 41464G09 | 9,5   | 24,5   | 900 | ●    |
| 41464C09 | 9,5   | 24,5   | 900 | ●    |
| 41464B09 | 9,5   | 24,5   | 900 | ●    |



SS

**Boston tin + half tin**

Shaker boston 2 pz  
Boston Shaker, 2 Stk  
Shaker boston, 2 pcs  
Coctelera boston, 2 pz

| art.     | Ø cm. | ml.     | col. |
|----------|-------|---------|------|
| 41467G08 | 9     | 790/590 | ●    |
| 41467C08 | 9     | 790/590 | ●    |
| 41467B08 | 9     | 790/590 | ●    |



SS

**Boston shaker, vinyl coated**

Cono boston, rivestimento vinile  
Boston-Shaker, Vinyl Überzug  
Shaker boston, revêtement en vinyle  
Coctelera boston, revestimiento vinilo

| art.     | Ø cm. | h. cm. | ml. | col. |
|----------|-------|--------|-----|------|
| 41479-11 | 9     | 18     | 830 | ●    |
| 41479-15 | 9     | 18     | 830 | ○    |



SS

**Boston shaker, vinyl coated**

Cono boston, rivestimento vinile  
Boston-Shaker, Vinyl Überzug  
Shaker boston, revêtement en vinyle  
Coctelera boston, revestimiento vinilo

| art.     | Ø cm. | h. cm. | ml. | col. |
|----------|-------|--------|-----|------|
| 41479-12 | 9     | 18     | 830 | ●    |
| 41479-13 | 9     | 18     | 830 | ●    |
| 41479-14 | 9     | 18     | 830 | ●    |



SS

**Boston shaker**

Cono boston con fondello  
Boston-Shaker  
Shaker boston  
Coctelera boston

| art.     | Ø cm. | h. cm. | ml. |
|----------|-------|--------|-----|
| 41479-05 | 9     | 17     | 500 |





**Mixing glass**

Bicchiere miscelatore  
Rührglas  
Verre mélangeur  
Vaso mezclador

| art.     | Ø cm. | h. cm. | ml. |
|----------|-------|--------|-----|
| 41479-AA | 8,5   | 15     | 500 |



**Mixing glass**

Bicchiere miscelatore  
Rührglas  
Verre mélangeur  
Vaso mezclador

| art.     | Ø cm. | h. cm. | ml. |
|----------|-------|--------|-----|
| 41478-50 | 8,8   | 15     | 473 |
| 41478-35 | 8,3   | 13     | 355 |



**Mixing glass**

Bicchiere miscelatore  
Rührglas  
Verre mélangeur  
Vaso mezclador

| art.     | Ø cm. | h. cm. | ml. |
|----------|-------|--------|-----|
| 41477-50 | 9     | 15     | 473 |

**With ounce markings. – Graduato in once.**



**Mixing glass with lip**

Bicchiere miscelatore con becco versatore  
Rührglas mit Lippe  
Verre mélangeur avec bec verseur  
Vaso mezclador vertedor con pico

| art.     | Ø cm. | h. cm. | lt. |
|----------|-------|--------|-----|
| 41514-05 | 9     | 16,5   | 0,5 |



**Mixing glass with lip**

Bicchiere miscelatore con becco versatore  
Rührglas mit Lippe  
Verre mélangeur avec bec verseur  
Vaso mezclador vertedor con pico

| art.     | Ø cm. | h. cm. | lt.  |
|----------|-------|--------|------|
| 41514-10 | 11,5  | 19     | 0,95 |



**Whiskey glass**

Bicchiere whiskey  
Whiskey Glas  
Verre à whiskey  
Vaso whiskey

| art.     | Ø cm. | h. cm. | ml. |
|----------|-------|--------|-----|
| 44940-01 | 8,5   | 9,5    | 420 |

**U.Pack 6 pcs**

**PC**



**Juice glass**

Bicchiere succo  
Fruchtsaft-Glas  
Verre à jus  
Vaso zumo

| art.     | Ø cm. | h. cm. | ml. |
|----------|-------|--------|-----|
| 44940-02 | 7,5   | 15,5   | 460 |

**U.Pack 6 pcs**

**PC**



**Beer glass**

Boccale birra  
Bier-Glas  
Verre à bière  
Vaso cerveza

| art.     | Ø cm. | h. cm. | ml. |
|----------|-------|--------|-----|
| 44940-06 | 8     | 23     | 450 |

**U.Pack 6 pcs**

**PC**



**Beer glass**

Boccale birra  
Bier-Glas  
Verre à bière  
Vaso cerveza

| art.     | Ø cm. | h. cm. | ml. |
|----------|-------|--------|-----|
| 44940-08 | 9     | 16     | 500 |

**U.Pack 6 pcs**

**SMMA**



**Margarita glass**

Bicchiere margarita  
Margarita-Glas  
Verre à margarita  
Vaso margarita

| art.     | Ø cm. | h. cm. | ml. |
|----------|-------|--------|-----|
| 44940-10 | 12    | 18     | 300 |

**U.Pack 6 pcs**

**PC**





PC

**Martini glass**  
Bicchiere martini  
Martini-Glas  
Verre à martini  
Vaso martini

| art.     | Ø cm. | h. cm. | ml. |
|----------|-------|--------|-----|
| 44940-11 | 12    | 17     | 240 |

U.Pack 6 pcs



PC

**Wine glass**  
Bicchiere vino  
Wein-Glas  
Verre à vin  
Vaso vino

| art.     | Ø cm. | h. cm. | ml. |
|----------|-------|--------|-----|
| 44940-12 | 7     | 21     | 300 |

U.Pack 6 pcs



PC

**Wine glass**  
Bicchiere vino  
Wein-Glas  
Verre à vin  
Vaso vino

| art.     | Ø cm. | h. cm. | ml. |
|----------|-------|--------|-----|
| 44940-13 | 7     | 19     | 200 |

U.Pack 6 pcs



PC

**Champagne glass**  
Bicchiere spumante  
Sekt-Glas  
Flûte  
Vaso champaña

| art.     | Ø cm. | h. cm. | ml. |
|----------|-------|--------|-----|
| 44940-14 | 5     | 22     | 180 |

U.Pack 6 pcs



PC

**Mixing glass**  
Bicchiere  
Glas  
Verre  
Vaso

| art.     | Ø cm. | h. cm. | ml. |
|----------|-------|--------|-----|
| 44940-16 | 9     | 16     | 540 |

U.Pack 6 pcs



PC

**Whiskey/rocks glass**  
Bicchiere whiskey/rocks  
Whiskey-/Rocks-Glas  
Verre à whiskey/rocks  
Vaso whiskey/rocks

| art.     | Ø cm. | h. cm. | ml. |
|----------|-------|--------|-----|
| 44940-17 | 9     | 12     | 420 |

U.Pack 6 pcs



PC

**Whiskey/rocks glass**  
Bicchiere whiskey/rocks  
Whiskey-/Rocks-Glas  
Verre à whiskey/rocks  
Vaso whiskey/rocks

| art.     | Ø cm. | h. cm. | ml. |
|----------|-------|--------|-----|
| 44940-18 | 8,5   | 11,5   | 420 |

U.Pack 6 pcs



PC

**Cooler glass**  
Bicchiere  
Glas  
Verre  
Vaso

| art.     | Ø cm. | h. cm. | ml. |
|----------|-------|--------|-----|
| 44940-19 | 8     | 17     | 540 |

U.Pack 6 pcs



PC

**Tumbler**  
Bicchiere  
Trinkbecher  
Gobelet  
Vaso

| art.     | Ø cm. | h. cm. | ml. |
|----------|-------|--------|-----|
| 44940-24 | 7,5   | 12,5   | 360 |
| 44940-25 | 8,0   | 13,5   | 480 |
| 44940-26 | 8,5   | 16,0   | 660 |

U.Pack 6 pcs







**PC**

**Tumbler**  
Bicchiere  
Trinkbecher  
Gobelet  
Vaso

| art.     | Ø cm. | h. cm. | ml. |
|----------|-------|--------|-----|
| 44940-32 | 7,5   | 12,5   | 360 |
| 44940-33 | 8,0   | 13,5   | 480 |
| 44940-34 | 8,5   | 16,0   | 660 |

**U.Pack 6 pcs**



**SAN**

**Tumbler**  
Bicchiere  
Trinkbecher  
Gobelet  
Vaso

| art.     | Ø cm. | h. cm. | ml. |
|----------|-------|--------|-----|
| 44990-15 | 5,5   | 9,5    | 150 |
| 44990-24 | 6,5   | 10,0   | 240 |
| 44990-29 | 7,0   | 11,0   | 290 |
| 44990-36 | 7,5   | 13,0   | 360 |
| 44990-48 | 8,0   | 15,0   | 480 |

**U.Pack 6 pcs**



**Cover with spout**  
Coperchio con beccuccio  
Deckel mit Ausguss  
Couverture avec bec  
Tapa con boquilla

| art.     | Ø cm. | U. Pack |
|----------|-------|---------|
| 44871-23 | 7     | 10      |

**TPE. For PC glasses 250 ml.**  
TPE. Per bicchieri in PC da 250 ml.



**PC**

**Water tumbler**  
Bicchiere acqua  
Wasserglas  
Verre à eau  
Vaso agua

| art.     | Ø cm. | h. cm. | ml. | U. Pack | col. |
|----------|-------|--------|-----|---------|------|
| 44871-20 | 7,0   | 7,0    | 170 | 50      | ○    |
| 44871-21 | 7,0   | 10,2   | 250 | 30      | ○    |
| 44871-22 | 7,8   | 11,4   | 350 | 30      | ○    |



**PC**

**Water tumbler**  
Bicchiere acqua  
Wasserglas  
Verre à eau  
Vaso agua

| art.     | Ø cm. | h. cm. | ml. | U. Pack | col. |
|----------|-------|--------|-----|---------|------|
| 44871R20 | 7,0   | 7,0    | 170 | 50      | ●    |
| 44871L20 | 7,0   | 7,0    | 170 | 50      | ●    |
| 44871G20 | 7,0   | 7,0    | 170 | 50      | ●    |
| 44871B20 | 7,0   | 7,0    | 170 | 50      | ●    |



**PC**

**Water tumbler**  
Bicchiere acqua  
Wasserglas  
Verre à eau  
Vaso agua

| art.     | Ø cm. | h. cm. | ml. | U. Pack | col. |
|----------|-------|--------|-----|---------|------|
| 44871R21 | 7,0   | 10,2   | 250 | 30      | ●    |
| 44871L21 | 7,0   | 10,2   | 250 | 30      | ●    |
| 44871G21 | 7,0   | 10,2   | 250 | 30      | ●    |
| 44871B21 | 7,0   | 10,2   | 250 | 30      | ●    |



**PC**

**Water jug**  
Caraffa  
Wasserkrug  
Crûche à eau  
Jarra agua

| art.     | dim. cm.  | l.  |
|----------|-----------|-----|
| 44871-28 | 12x13,8   | 0,5 |
| 44871-30 | 17,4x17   | 1,0 |
| 44871-32 | 18,7x19,8 | 1,5 |
| 44871-34 | 21,6x18,8 | 2,0 |

**Withstands temperatures/Termoresistenti da: -30° +120°C.**



PP

Lid  
Coperchio  
Deckel  
Couvercle  
Tapa

| art.     | dim. cm. | fits/per | U. Pack |
|----------|----------|----------|---------|
| 44871-29 | 9,9x1,4  | l. 0,5   | 10      |
| 44871-31 | 11,2x1,9 | l. 1,0   | 10      |
| 44871-33 | 14x2,4   | l. 1,5   | 10      |
| 44871-35 | 15,9x2,2 | l. 2,0   | 10      |

Withstands temperatures/Termoresistenti  
da: -40° +100°C.



SMMA

Cocktail glass  
Bicchiere cocktail  
Cocktail Glas  
Verre à cocktail  
Vaso cocktail

| art.     | Ø cm. | h. cm. | ml. |
|----------|-------|--------|-----|
| 44942-01 | 8     | 21     | 350 |

U.Pack 6 pcs



SMMA

Cocktail glass  
Bicchiere cocktail  
Cocktail Glas  
Verre à cocktail  
Vaso cocktail

| art.     | Ø cm. | h. cm. | ml. |
|----------|-------|--------|-----|
| 44942-02 | 11    | 21     | 460 |

U.Pack 6 pcs



SMMA

Martini glass  
Bicchiere martini  
Martini-Glas  
Verre à martini  
Vaso martini

| art.     | Ø cm. | h. cm. | ml. |
|----------|-------|--------|-----|
| 44942-03 | 10,5  | 20     | 340 |

U.Pack 6 pcs



SMMA

Cocktail glass  
Bicchiere cocktail  
Cocktail Glas  
Verre à cocktail  
Vaso cocktail

| art.     | Ø cm. | h. cm. | ml. |
|----------|-------|--------|-----|
| 44942-04 | 7,5   | 23     | 220 |

U.Pack 6 pcs



SMMA

Margarita glass  
Bicchiere margarita  
Margarita-Glas  
Verre à margarita  
Vaso margarita

| art.     | Ø cm. | h. cm. | ml. |
|----------|-------|--------|-----|
| 44942-05 | 12    | 17,5   | 340 |

U.Pack 6 pcs



SS

Fruit basket  
Cesto agrumi  
Obstkorb  
Panier à fruits  
Cesta frutas

| art.     | Ø cm. | h. cm. |
|----------|-------|--------|
| 41611-20 | 21,5  | 20     |





SS

**Fruit basket, oval**  
Cesto frutta, ovale  
Obstschale, oval  
Panier à fruits, ovale  
Cesta fruta, oval

| art.     | dim. cm. |
|----------|----------|
| 42956-19 | 19x15    |
| 42956-24 | 24,5x18  |
| 42956-28 | 28x21    |



NEW

**Serving stand 2-tier**  
Alzata 2 piani  
Serviergestell, 2-stufig  
Présentoir 2 étages  
Soporte 2 niveles

| art.     | dim. cm. |
|----------|----------|
| 41208-06 | 31x17x38 |

**Black metal frame with non-slip feet, 2 baskets 29x16x7 cm, 2 acacia wood boards 28,5x15,5x1,5 cm.** – Struttura in metallo nero con piedini antiscivolo, 2 cesti cm 29x16x7, 2 assi in legno di acacia cm 28,5x15,5x1,5.



NEW

**Fruit basket 2-tier**  
Cesto agrumi 2 piani  
Obstkorb, 2-stufig  
Panier à fruits 2 étages  
Cesta frutas 2 niveles

| art.     | Ø cm. | h. cm. |
|----------|-------|--------|
| 41208-02 | 22/26 | 48     |

**Wooden handle, metal black baskets Ø 22 H 6 cm and Ø 26 H 8 cm.** – Manico legno, cesti in metallo nero Ø 22 H 6 cm e Ø 26 H 8 cm.



**Orange juicer, chromed**  
Spremiagrumi manuale, cromato  
Orangenpresse, verchromt  
Presse-agrumes, chromé  
Exprimidor de cítricos, cromado

| art.     | dim. cm. |
|----------|----------|
| 41456-02 | 18x13x46 |



SS

**Lemon squeezer**  
Spremilimone  
Zitronenpresse  
Presse citron  
Exprime limones

| art.     | dim. cm. |
|----------|----------|
| 41606-00 | 12,5x6,5 |



SS

**Lemon squeezer**  
Spremilimone  
Zitronenpresse  
Presse citron  
Exprime limones

| art.     | dim. cm. |
|----------|----------|
| 41606-01 | 7x8,5    |



**Lemon squeezer, aluminum**  
Spremilimone, alluminio  
Zitronenpresse, aluminum  
Presse citron, alu  
Exprime limones, aluminio

| art.     | l. cm. |
|----------|--------|
| 41606-02 | 20     |



**Lemon/lime squeezer, aluminum**  
Spremilimone/lime, alluminio  
Zitronen-/Limettenpresse, aluminum  
Presse citron, alu  
Exprimidor de limón/lima, aluminio

| art.     | dim. cm. |
|----------|----------|
| 41606-22 | 22x7,5   |

**3 pieces, powder coated yellow and green.**  
3 pezzi, verniciati a polvere giallo e verde.





**Soda siphon**

Sifone soda  
Soda Siphon  
Siphon à eau de seltz  
Sifón agua de seltz

art. lt.  
41453-11 1



**Soda siphon**

Sifone soda  
Soda Siphon  
Siphon à eau de seltz  
Sifón agua de seltz

art. lt.  
41465-10 1



**Soda siphon**

Sifone soda  
Soda Siphon  
Siphon à eau de seltz  
Sifón agua de seltz

art. lt.  
41454-01 1



**2 Bottles Twist&Sparkle**

2 Bottiglie Twist&Sparkle  
2 Flaschen Twist&Sparkle  
2 Bouteilles Twist&Sparkle  
2 Botellas Twist&Sparkle

art. lt.  
41454-99 1



**Soda chargers, 10-pcs set**

Ricariche soda, 10 pezzi  
10-Stk. Sodakapseln-Packung  
Capsules à eau de seltz, set 10 pcs  
Cápsulas para agua de seltz, 10 pz

art.  
41453-AA

**Content: 8 g of CO2. – Contenuto: 8 gr di CO2.**



**Ice pick**

Rompighiaccio  
Eisstößel  
Casse-glace  
Pico para hielo

art. l. cm.  
44105-00 23

**Wooden handle. – Manico legno.**



**Muddler, plastic**

Pestaghiaccio, plastica  
Eiszerstosser, Kunststoff  
Pic à glace, plastique  
Pico para hielo, plástico

art. l. cm.  
41503-22 22,5



SS

**Muddler**

Pestaghiaccio  
Eiszerstosser  
Pic à glace  
Pico para hielo

art. l. cm.  
41503-21 20



**Ice crusher, chromed**

Tritaghiaccio, cromato  
Eiswolf, verchromt  
Broyer à glace, chromé  
Trituradora de hielo, cromada

art. dim. cm.  
41457-00 15x12x26



SS

**Ice scoop**

Sessola per ghiaccio  
Eisschaufel  
Pelle à glace  
Librador para hielo

art. ml.  
41503-00 100



PC

**Ice scoop**

Sessola per ghiaccio  
Eisschaufel  
Pelle à glace  
Librador para hielo

art. ml.  
14958-01 100  
14958-02 250



SS

**Ice spoon**

Cucchiaio ghiaccio  
Eislöffel  
Cuillère à glace  
Cuchara hielo

art. l. cm.  
12550-04 22





**Mold for ice-balls**

Stampo sfere di ghiaccio  
Eis-Kugel-Former  
Moule pour boules de glace  
Molde bolas de hielo

art. dim. cm.  
41515-03 24x8,5

**For 3 balls ø 5,5 cm, 100 ml.**  
Per 3 sfere ø 5,5 cm da 100 ml.



**Mold for ice-ball, silicone**

Stampo sfera di ghiaccio, silicone  
Eis-Kugel-Former, Silikon  
Moule à boule de glace, silicone  
Molde bola de hielo, silicona

art. dim. cm.  
41515-10 6,8x7,5

**For 1 ball ø 6 cm. – Per 1 sfera ø 6 cm.**



**Mold for ice-balls, silicone**

Stampo sfere di ghiaccio, silicone  
Eis-Kugel-Former, Silikon  
Moule à boules de glace, silicone  
Molde bolas de hielo, silicona

art. dim. cm.  
41515-08 12x12x5

**For 4 balls ø 4,5 cm. – Per 4 sfere ø 4,5 cm.**



**Mold for ice-balls, silicone**

Stampo sfere di ghiaccio, silicone  
Eis-Kugel-Former, Silikon  
Moule à boules de glace, silicone  
Molde bolas de hielo, silicona

art. dim. cm.  
41515-09 23,5x12,8x5

**For 8 balls ø 4 cm. – Per 8 sfere ø 4 cm.**



**Mold for ice-skulls, silicone**

Stampo teschi ghiaccio, silicone  
Eis-Schädel-Former, Silikon  
Moule à crânes de glace, silicone  
Molde de crâneos de hielo, silicona

art. dim. cm.  
41515-05 11x8



**Mold for ice-cubes, silicone**

Stampo cubetti ghiaccio, silicone  
Eiswürfel-Former, Silikon  
Moule à glaçons, silicone  
Molde cubitos de hielo, silicona

art. dim. cm.  
41515-20 27x14x3,5

**For 21 cubes 3 cm. – Per 21 cubetti 3 cm.**



**Mold for ice-cubes, silicone**

Stampo cubetti ghiaccio, silicone  
Eiswürfel-Former, Silikon  
Moule à glaçons, silicone  
Molde cubitos de hielo, silicona

art. dim. cm.  
41515-21 25x12x3

**For 32 cubes 2,5 cm. – Per 32 cubetti 2,5 cm.**



**Mold for ice-diamonds, silicone**

Stampo diamanti ghiaccio, silicone  
Eis-Diamant-Former, Silikon  
Moule à diamants de glace, silicone  
Molde de diamante de hielo, silicona

art. dim. cm.  
41515-07 12x12



**Mold for ice-balls, silicone**

Stampo sfere di ghiaccio, silicone  
Eis-Kugel-Former, Silikon  
Moule à boules de glace, silicone  
Molde bolas de hielo, silicona

art. dim. cm.  
41515-22 24x13x2

**For 40 balls ø 1 cm. – Per 40 sfere ø 1 cm.**





SS

**Ice tongs**

Molla ghiaccio  
Eiszange  
Pince à glace  
Pinza hielo

| art.     | l. cm. | col. |
|----------|--------|------|
| 41518G12 | 16     | ●    |
| 41518C12 | 16     | ●    |
| 41518B12 | 16     | ●    |



**Ice bucket with tongs**

Secchio ghiaccio e pinza  
Eiseimer mit Eiszange  
Seau à glace avec pince  
Cubo hielo con pinza

| art.     | Ø mm. | h. cm. | lt. |
|----------|-------|--------|-----|
| 41513-13 | 14    | 22     | 1,3 |

**Noble plastic jacket highly chrome plated with special insulated plastic insert.**

Camicia in materiale plastico, finitura cromata lucida con speciale inserto termico.



**Ice bucket, plastic**

Secchio ghiaccio, plastica  
Eiseimer, Kunststoff  
Seau à glace, plastique  
Cubo hielo, plástico

| art.     | Ø mm. | h. cm. | lt. |
|----------|-------|--------|-----|
| 41512-15 | 15    | 15     | 1,5 |
| 41512-30 | 20    | 18     | 3,0 |

**Satin metal look with highly polished edge.**

**Special insulated plastic insert.**

Finitura effetto metallo satinato, bordo lucido. Speciale inserto termico.



PP

SAN

**Ice box**

Secchio ghiaccio  
Eisbox  
Seau à glace  
Cubitera

| art.     | dim. cm. | lt. |
|----------|----------|-----|
| 41512-50 | 27x27x15 | 5,4 |

**With drainer. – Con griglia.**



SS

**Ice bucket**

Secchio ghiaccio  
Eisbehälter  
Seau à glace  
Cubitera hielo

| art.     | Ø cm. | h. cm. |
|----------|-------|--------|
| 46116-15 | 12,5  | 13     |



SS

**Ice bucket**

Secchio ghiaccio  
Eisbehälter  
Seau à glace  
Cubitera hielo

| art.     | Ø cm. | h. cm. | lt. | col. |
|----------|-------|--------|-----|------|
| 41513G20 | 15    | 14     | 2   | ●    |
| 41513C20 | 15    | 14     | 2   | ●    |
| 41513B20 | 15    | 14     | 2   | ●    |



**Bar organizer**

Porta oggetti da bar  
Bar-Behälter  
Présentoir de bar  
Dispensador bar

| art.     | dim. cm.   |
|----------|------------|
| 44102-24 | 24x14,5x11 |



**Flair bottle**

Flair bottle  
Flair bottle  
Flair bottle  
Flair bottle

| art.     | lt.  | col. |
|----------|------|------|
| 44108-01 | 0,75 | ○    |
| 44108-02 | 0,75 | ●    |



ABS

**Smoking gun**

Affumicatore  
Räuchergerät  
Pistolet à fumer  
Ahumador aromatizador

| art.     | dim. cm.      |
|----------|---------------|
| 49923-00 | 16,2x5,5x12,5 |

**DC6V - 3,0L/min. Ideal for flavoring and smoking liquid and solid products, such as: cocktails, vegetables, meat and fish. – Ideale per aromatizzare e affumicare prodotti liquidi e solidi, come: cocktail, verdure, carne e pesce.**



**NEW**

**Smoking chips**

Segatura aromatizzata  
Aromatisiertes Sägemehl  
Sciure aromatisée  
Serrín aromatizado

art. ml.  
49923-99 4x250

**Mesquite/Hickory/Oak/Cherry.**  
Mesquite/Hickory/Rovere/Ciliegio.



**Cocktail cover**

Cloche per affumicatore  
Cocktail Räucherglocke  
Cloche à fumée  
Campana para ahumado

art. Ø cm. h. cm.  
49923-01 12 11  
49923-02 12 16

**Glass cover, wood base ø 15 cm.**  
Cloche vetro, base legno ø 15 cm.



**NEW**

**PC**

**Cocktail cover**

Cloche per affumicatore  
Cocktail Räucherglocke  
Cloche à fumée  
Campana para ahumado

art. Ø cm. h. cm.  
49924-21 21 17  
49924-31 30 22  
49924-36 36 27



**Skull dash bottle**

Bottiglia angostura teschio  
Schädel Dash Bottle  
Dash bottle crâne  
Dash bottle cráneo

art. ml.  
41680-03 30  
41680-06 60  
41680-12 120



**Atomizer dash bottle**

Bottiglia angostura spray  
Bitter Flasche Atomizer  
Vaporisateur d'angostura  
Botella angostrura spray

art. ml.  
41681-10 100



**Atomizer dash bottle**  
Bottiglia angostura spray  
Bitter Flasche Atomizer  
Vaporisateur d'angostura  
Botella angostrura spray

| art.     | h. cm. | ml. |
|----------|--------|-----|
| 41681-11 | 15     | 50  |



**Atomizer dash bottle**  
Bottiglia angostura spray  
Bitter Flasche Atomizer  
Vaporisateur d'angostura  
Botella angostrura spray

| art.     | Ø cm. | h. cm. | ml. | col. |
|----------|-------|--------|-----|------|
| 41681-12 | 7     | 10     | 100 | ●    |



**Dash bottle**  
Bottiglia angostura  
Bitter Flasche  
Dash bottle  
Botella angostrura

| art.     | ml. |
|----------|-----|
| 41681-06 | 150 |



**Dash Bottle**  
Bottiglia angostura  
Bitter Flasche  
Dash Bottle  
Botella Angostrura

| art.     | dim. cm.   | ml. |
|----------|------------|-----|
| 41681-01 | 6,5x6,5x10 | 100 |



**Dash Bottle**  
Bottiglia angostura  
Bitter Flasche  
Dash Bottle  
Botella Angostrura

| art.     | Ø cm. | h. cm. | ml. |
|----------|-------|--------|-----|
| 41681-03 | 8,5   | 15     | 280 |



**Dash Bottle**  
Bottiglia angostura  
Bitter Flasche  
Dash Bottle  
Botella Angostrura

| art.     | dim. cm. | ml. |
|----------|----------|-----|
| 41681-02 | 6x5x15   | 200 |

Without pourer. – Senza dosatore.



**Dash Bottle**  
Bottiglia angostura  
Bitter Flasche  
Dash Bottle  
Botella Angostrura

| art.     | Ø cm. | h. cm. | ml. |
|----------|-------|--------|-----|
| 41681-04 | 6,2   | 10     | 100 |

Without pourer. – Senza dosatore.



**Bottle pourer**  
Tappo versatore  
Ausgiesser  
Bouchon verseur  
Tapón vertedor

| art.     |
|----------|
| 41681-99 |



PE

**Store & pour container**  
Contentitore versatore  
Dosier-Vorratsbehälter, komplett  
Bouteille verseuse  
Recipiente vertedor

| art.     | Ø cm. | h. cm. | lt. | col. |
|----------|-------|--------|-----|------|
| 44106W05 | 9,0   | 26     | 0,5 | ○    |
| 44106W10 | 9,0   | 33     | 1,0 | ○    |
| 44106W20 | 12,5  | 35     | 2,0 | ○    |
| 44106W25 | 12,5  | 39     | 2,5 | ○    |



PE

**Store & pour container**  
Contentitore versatore  
Dosier-Vorratsbehälter, komplett  
Bouteille verseuse  
Recipiente vertedor

| art.     | Ø cm. | h. cm. | lt. | col. |
|----------|-------|--------|-----|------|
| 44106G05 | 9,0   | 26     | 0,5 | ●    |
| 44106G10 | 9,0   | 33     | 1,0 | ●    |
| 44106G20 | 12,5  | 35     | 2,0 | ●    |
| 44106G25 | 12,5  | 39     | 2,5 | ●    |



PE

**Store & pour container**  
Contentitore versatore  
Dosier-Vorratsbehälter, komplett  
Bouteille verseuse  
Recipiente vertedor

| art.     | Ø cm. | h. cm. | lt. | col. |
|----------|-------|--------|-----|------|
| 44106Y05 | 9,0   | 26     | 0,5 | ●    |
| 44106Y10 | 9,0   | 33     | 1,0 | ●    |
| 44106Y20 | 12,5  | 35     | 2,0 | ●    |
| 44106Y25 | 12,5  | 39     | 2,5 | ●    |





PE

**Store & pour container**

Contentitore versatore  
Dosier-Vorratsbehälter, komplett  
Bouteille verseuse  
Recipiente vertedor

| art.     | Ø cm. | h. cm. | lt. | col. |
|----------|-------|--------|-----|------|
| 44106R05 | 9,0   | 26     | 0,5 | ●    |
| 44106R10 | 9,0   | 33     | 1,0 | ●    |
| 44106R20 | 12,5  | 35     | 2,0 | ●    |
| 44106R25 | 12,5  | 39     | 2,5 | ●    |



PE

**Store & pour container**

Contentitore versatore  
Dosier-Vorratsbehälter, komplett  
Bouteille verseuse  
Recipiente vertedor

| art.     | Ø cm. | h. cm. | lt. | col. |
|----------|-------|--------|-----|------|
| 44106O05 | 9,0   | 26     | 0,5 | ●    |
| 44106O10 | 9,0   | 33     | 1,0 | ●    |
| 44106O20 | 12,5  | 35     | 2,0 | ●    |
| 44106O25 | 12,5  | 39     | 2,5 | ●    |



PE

**Store & pour container**

Contentitore versatore  
Dosier-Vorratsbehälter, komplett  
Bouteille verseuse  
Recipiente vertedor

| art.     | Ø cm. | h. cm. | lt. | col. |
|----------|-------|--------|-----|------|
| 44106B05 | 9,0   | 26     | 0,5 | ●    |
| 44106B10 | 9,0   | 33     | 1,0 | ●    |
| 44106B20 | 12,5  | 35     | 2,0 | ●    |
| 44106B25 | 12,5  | 39     | 2,5 | ●    |



PE

**Storage canister**

Contentitore di riserva  
Vorratsbehälter  
Réipient réserve  
Recipiente reserva

| art.     | Ø cm. | h. cm. | lt. | col. |
|----------|-------|--------|-----|------|
| 44107W05 | 9,0   | 9,5    | 0,5 | ○    |
| 44107W10 | 9,0   | 16     | 1,0 | ○    |
| 44107W20 | 12,5  | 20     | 2,0 | ○    |
| 44107W25 | 12,5  | 23     | 2,5 | ○    |



PE

**Storage canister**

Contentitore di riserva  
Vorratsbehälter  
Réipient réserve  
Recipiente reserva

| art.     | Ø cm. | h. cm. | lt. | col. |
|----------|-------|--------|-----|------|
| 44107G05 | 9,0   | 9,5    | 0,5 | ●    |
| 44107G10 | 9,0   | 16     | 1,0 | ●    |
| 44107G20 | 12,5  | 20     | 2,0 | ●    |
| 44107G25 | 12,5  | 23     | 2,5 | ●    |



PE

**Storage canister**

Contentitore di riserva  
Vorratsbehälter  
Réipient réserve  
Recipiente reserva

| art.     | Ø cm. | h. cm. | lt. | col. |
|----------|-------|--------|-----|------|
| 44107Y05 | 9,0   | 9,5    | 0,5 | ●    |
| 44107Y10 | 9,0   | 16     | 1,0 | ●    |
| 44107Y20 | 12,5  | 20     | 2,0 | ●    |
| 44107Y25 | 12,5  | 23     | 2,5 | ●    |



PE

**Storage canister**

Contentitore di riserva  
Vorratsbehälter  
Réipient réserve  
Recipiente reserva

| art.     | Ø cm. | h. cm. | lt. | col. |
|----------|-------|--------|-----|------|
| 44107R05 | 9,0   | 9,5    | 0,5 | ●    |
| 44107R10 | 9,0   | 16     | 1,0 | ●    |
| 44107R20 | 12,5  | 20     | 2,0 | ●    |
| 44107R25 | 12,5  | 23     | 2,5 | ●    |



PE

**Storage canister**

Contentitore di riserva  
Vorratsbehälter  
Réipient réserve  
Recipiente reserva

| art.     | Ø cm. | h. cm. | lt. | col. |
|----------|-------|--------|-----|------|
| 44107O05 | 9,0   | 9,5    | 0,5 | ●    |
| 44107O10 | 9,0   | 16     | 1,0 | ●    |
| 44107O20 | 12,5  | 20     | 2,0 | ●    |
| 44107O25 | 12,5  | 23     | 2,5 | ●    |



PE

**Storage canister**

Contentitore di riserva  
Vorratsbehälter  
Réipient réserve  
Recipiente reserva

| art.     | Ø cm. | h. cm. | lt. | col. |
|----------|-------|--------|-----|------|
| 44107B05 | 9,0   | 9,5    | 0,5 | ●    |
| 44107B10 | 9,0   | 16     | 1,0 | ●    |
| 44107B20 | 12,5  | 20     | 2,0 | ●    |
| 44107B25 | 12,5  | 23     | 2,5 | ●    |



PS

**Pouring container cap**

Tappo per versatore  
Dosier-Behälterstopfen  
Bouchon à bouteille verseuse  
Tapón para recipiente vertedor

| art.     | pcs/pz |
|----------|--------|
| 44106-12 | 12     |



PS

PP

**Condiment holder**

Portacondimenti  
Bar-Beilagenbehälter  
Boîte à condiments  
Caja condimentos

| art.     | dim. cm. | comp. |
|----------|----------|-------|
| 44103-03 | 49x15x9  | 3     |
| 44103-04 | 49x15x9  | 4     |
| 44103-06 | 49x15x9  | 6     |



SS

**Condiment holder**

Portacondimenti  
Bar-Beilagenbehälter  
Boîte à condiments  
Caja condimentos

| art.     | dim. cm. | comp. |
|----------|----------|-------|
| 41782-04 | 32x16x10 | 4     |
| 41782-05 | 39x16x10 | 5     |
| 41782-06 | 47x16x10 | 6     |



**Glass rimmer**

Bordatore bicchieri  
Bar-Kombination Salz-/Zuckerumranden  
Système de givrage de verres  
Ribeteador de vasos

| art.     | Ø cm. |
|----------|-------|
| 44101-03 | 15,5  |



PE

**Bar liner**

Tappeto sottobicchieri  
Gläsermatte  
Revêtement de bar  
Tapete para vasos

| art.     | dim. cm. |
|----------|----------|
| 44099-03 | 60x1300  |



**Bar mat, non-slip**

Tappeto antiscivolo componibile  
Gläserabstellmatte, rutschfest  
Tapis antidérapant, composable  
Alfombra antiderrapante, componible

| art.     | dim. cm. |
|----------|----------|
| 44100-04 | 30x30    |



**Bar runner**

Tappetino bar  
Gläserabstellmatte  
Tapis à verres  
Tapete para vasos

| art.     | dim. cm. |
|----------|----------|
| 44100-01 | 68x8     |
| 44100-02 | 45x30    |





**Barman's set, 20 pcs**

Valigia Barman, 20 pz  
Barman-Koffer, 20 Stk.  
Mallette de barman, 20 pièces  
Alfombra, 20 piezas

art.  
14480-20

**Incl. –** Comprende: 41479-05 boston shaker, 41480-05 shaker, 41503-22 pestello/ice beater, 41595-20 cucchiaino magico/magic spoon, 41603-00 colino/strainer, 41604-00 misurino/measuring cup, 41605-00 miscelatore/mixing spoon, 41606-00 & 41606-01 spremilimone/lemon squeezer, 41606-02 spremi lime/lime squeezer, 41608-04 tappo/champagne stopper, 41699-06 cavatappi/corkscrew, 44058-10 tappo dosatore/dispenser plug 10ml, 48280-02 levacapsule/bottle opener, 48280-97 coltello barman/barman knife, 48280-92 rigalimoni/lemon striper, 48280-96 pelarance/orange peeler, 12550-04 cucchiaino ghiaccio/ice spoon, 12550-36 cucchiaino bibita/cocktail spoon, 12550-55 molla ghiaccio/ice tong.



**Barman apron**  
Grembiule barman  
Barman Schurz  
Tablier barman  
Mandil barman

art. dim. cm.  
48543-01 70x40

**65% polyester/poliestere. – 35% cotton/cotone. 195 g/mq.**



**Barman apron**  
Grembiule barman  
Barman Schurz  
Tablier barman  
Mandil barman

art. dim. cm.  
48543-02 70x40

**65% polyester/poliestere. – 35% cotton/cotone. 195 g/mq.**



SS

**Speed rack**  
Rastrelliera  
Flaschenregal  
Rack à bouteilles  
Estantería bar para botellas

| art.     | dim. cm.      | bot. |
|----------|---------------|------|
| 44060-50 | 56x10,5x15,5  | 6    |
| 44060-80 | 81x10,5x15,5  | 8    |
| 44060-99 | 107x10,5x15,5 | 10   |



SS

**Speed rack**  
Rastrelliera  
Flaschenregal  
Rack à bouteilles  
Estantería bar para botellas

| art.     | dim. cm.   | bot. |
|----------|------------|------|
| 44060-51 | 56x21x15,5 | 2x 6 |



SS

**Glass shelf rack**  
Rastrelliera, fissaggio sospeso  
Gläserhalter Regalmontage  
Rack à verres fixation suspendue  
Rack de copas, fijación techo

| art.     | dim. cm.    |
|----------|-------------|
| 44060-01 | 45x31,6x5,5 |



SS

**Glass wall rack**  
Rastrelliera, fissaggio murale  
Gläserhalter Wandmontage  
Rack à verres fixation murale  
Rack de copas, fijación mural

| art.     | dim. cm.    |
|----------|-------------|
| 44060-02 | 45x31,6x5,6 |



SS

**Glass cleaning brush**  
Lavabicchieri  
Gläserpüler  
Brosse lave-verres  
Cepillo lavavasos

| art.     | dim. cm. |
|----------|----------|
| 44135-02 | 38x18x29 |



**Glass cleaning brush, nylon**  
Spazzole lavabicchieri, nylon  
Bierglasbürstenständer, nylon  
Brosse lave-verres, nylon  
Cepillo lavavasos, nilón

| art.     | h. cm. |
|----------|--------|
| 44130-02 | 16,5   |
| 44130-03 | 21,5   |



**Glass cleaning brush, nylon-aluminum**  
Spazzola lavabicchieri, nylon-alluminio  
Bierglasbürstenständer, Nylon-Aluminium  
Brosse lave-verres, nylon-alu  
Cepillo lavavasos, nilón-aluminio

| art.     | Ø cm. | h. cm. |
|----------|-------|--------|
| 44130-01 | 15    | 19     |



**Aluminum wall mounter bottle rack**  
Supporto a parete, alluminio  
Alu-Wandständer  
Support pour bouteilles en aluminium  
Soporte mural, aluminio

| art.     | l. cm. | bot. |
|----------|--------|------|
| 44056-04 | 41     | 4    |
| 44056-06 | 67     | 6    |

Dispensers not included. – Dosatori non inclusi.



**Revolving bottle rack**  
Supporto rotante da banco  
Theken-Drehständer vollständig  
Support rotatif de comptoir  
Soporte giratorio

| art.     | h. cm. | bot. |
|----------|--------|------|
| 44057-04 | 70     | 4    |
| 44057-06 | 70     | 6    |

Dispensers not included. – Dosatori non inclusi.







**Standard aluminum support**

Supporto bottiglia, alluminio  
Alu-Standard Ständer,  
Support en aluminium  
Soporte de botella, aluminio

| art.     | col. |
|----------|------|
| 44056-01 | ●    |
| 44056-11 | ●    |
| 44056-21 | ●    |

**Universal fitting, shelf or wall mounting.**

Fissaggio universale, a ripiano o parete.



**Chrome plated dispenser**

Dosatore cromato  
Verchromter Dosierer  
Doseur chromé  
Dosificador cromado

| art.     | ml. |
|----------|-----|
| 44055-10 | 10  |
| 44055-50 | 50  |



**Chrome plated dispenser**

Dosatore cromato  
Verchromter Dosierer  
Doseur chromé  
Dosificador cromado

| art.     | ml. |
|----------|-----|
| 44055-20 | 20  |
| 44055-25 | 25  |
| 44055-30 | 30  |
| 44055-35 | 35  |
| 44055-40 | 40  |



**Dispenser**

Dosatore  
Dosierer  
Doseur  
Dosificador

| art.     | ml. | col. |
|----------|-----|------|
| 44055G30 | 30  | ●    |
| 44055G40 | 40  | ●    |
| 44055C30 | 30  | ●    |
| 44055C40 | 40  | ●    |



**Automatic dispenser plug**

Tappo dosatore automatico  
Automatischer Portionierer  
Bouchon doseur automatique  
Bola dosificadora

| art.     | ml. |
|----------|-----|
| 44058-20 | 20  |
| 44058-25 | 25  |
| 44058-30 | 30  |



**Automatic dispenser plug**

Tappo dosatore automatico  
Automatischer Portionierer  
Bouchon doseur automatique  
Bola dosificadora

| art.     | ml. |
|----------|-----|
| 44058-10 | 10  |
| 44058-40 | 40  |
| 44058-50 | 50  |



**Bottle pourer with stopper**

Tappo versatore con chiusura  
Ausgießer mit Kappe  
Bouchon avec clapet  
Tapón vertedor con cierre

| art.     | pcs/pz |
|----------|--------|
| 44111-02 | 2      |

SS



**Free flow pourer**

Tappo versatore continuo  
Permanentausgießer  
Bouchon verseur continu  
Vertedor continuo

| art.     | pcs/pz | col. |
|----------|--------|------|
| 44110-01 | 12     | ●    |
| 44110-02 | 12     | ●    |
| 44110-03 | 12     | ●    |



**Free flow pourer**

Tappo versatore continuo  
Permanentausgießer  
Bouchon verseur continu  
Vertedor continuo

| art.     | pcs/pz | col. |
|----------|--------|------|
| 44110-04 | 12     | ●    |
| 44110-05 | 12     | ○    |
| 44110-06 | 12     | ●    |



**Free flow pourer**

Tappo versatore continuo  
Permanentausgiesser  
Bouchon verseur continu  
Vertedor continuo

art. pcs/pz

44110-00 12



**Measuring pourer**

Tappo versatore dosatore  
Dosierausgiesser  
Bouchon verseur doseur  
Tapón vertedor dosificador

art. U. Pack col.

|          |   |   |
|----------|---|---|
| 44119-01 | 6 | ● |
| 44119-02 | 6 | ● |
| 44119-03 | 6 | ● |
| 44119-04 | 6 | ● |
| 44119-06 | 6 | ● |



**Measuring pourer**

Tappo versatore dosatore  
Dosierausgiesser  
Bouchon verseur doseur  
Tapón vertedor dosificador

art.

44114-01  
44114-02  
44114-03

SS



**Measured pourer**

Tappo metrico  
Portioniererausgiesser  
Bouchon doseur  
Caños dosificador

art. ml. U. Pack col.

|          |    |   |   |
|----------|----|---|---|
| 44118-10 | 10 | 6 | ● |
| 44118-20 | 20 | 6 | ● |
| 44118-25 | 25 | 6 | ● |
| 44118-30 | 30 | 6 | ● |



**Measured pourer**

Tappo metrico  
Portioniererausgiesser  
Bouchon doseur  
Caños dosificador

art. ml. U. Pack col.

|          |    |   |   |
|----------|----|---|---|
| 44118-35 | 35 | 6 | ● |
| 44118-40 | 40 | 6 | ● |
| 44118-50 | 50 | 6 | ○ |



**Whiskey pourer**

Tappo versatore  
Ausgiesser  
Bouchon verseur  
Vertedor

art. pcs/pz col.

|          |    |   |
|----------|----|---|
| 44112-01 | 12 | ● |
| 44112-02 | 12 | ○ |



**Champagne stopper**

Tappo spumante  
Sektflaschenstopfen  
Bouchon à champagne  
Tapón Champaña

art.

41608-20



**Champagne stopper**

Tappo spumante  
Sektflaschenstopfen  
Bouchon à champagne  
Tapón Champaña

art.

41608-04

SS



**Champagne stopper**

Tappo spumante  
Sektflaschenstopfen  
Bouchon à champagne  
Tapón Champaña

art.

41608-08

SS



**Champagne stopper**

Tappo spumante  
Sektflaschenstopfen  
Bouchon à champagne  
Tapón Champaña

art.

41608-00

SS



**Champagne stopper**

Tappo spumante  
Sektflaschenstopfen  
Bouchon à champagne  
Tapón Champaña

art.

46796-00

SS



**Wine stopper**

Tappo vino  
Weinflaschenstopfen  
Bouchon à vin  
Tapón vino

art.

41608-03

SS





SS  
ABS

**Vacuum pump wine preserver + 2 stoppers**

Pompa sottovuoto per vino + 2 tappi

Wein-Vakuum-Pumpe + 2 Stopfen

Pompe à vide d'air + 2 bouchons

Bomba vacío vino + 2 tapones

art.

41500-00



**Set 2 stoppers**

Set 2 tappi

Satz 2 Stopfen

Jeu 2 bouchons

Juego 2 tapones

art.

41500-AA



**Foil cutter**

Taglia capsula

Folienchneider

Coupe-capsules

Cortacápsulas

art.

49858-07



**Winged corkscrew**

Cavatappi a doppia leva

Korkenzieher mit Doppelhebel

Tire-bouchon à double levier

Sacacorchos a doble palanca

art.

41699-10



**Waiter's corkscrew**

Cavatappi cameriere

Kellner Korkenzieher

Tire-bouchon sommelier

Sacacorchos camarero

art.

41699-20



**Waiter's corkscrew**

Cavatappi cameriere

Kellner Korkenzieher

Tire-bouchon sommelier

Sacacorchos camarero

art.

41699-06



**Lever corkscrew**

Cavatappi a leva

Korkenzieher

Tire-bouchon

Sacacorchos

art.

49858-01



**Lever corkscrew**

Cavatappi a leva

Korkenzieher

Tire-bouchon

Sacacorchos

art.

49858-00



**Waiter's corkscrew case**

Valigetta cameriere  
Kellner Korkenzieher-Koffer  
Mallette tire-bouchon sommelier  
Maletín sacacorchos sumiller

art. 49858-06



**Bottle opener with collector box**

Levacapsule con contenitore di raccolta  
Flaschenöffner mit Sammelbehälter  
Décapsuleur avec récipient de récupération  
Abridor de botellas + caja de recuperación

art. 48223-00 dim. cm. 12x7x30



SS

**Bottle opener**

Levacapsule  
Flaschenöffner  
Décapsuleur  
Abrebotellas

| art.     | dim. cm. | col. |
|----------|----------|------|
| 41699-18 | 18x4     | ●    |
| 41699G18 | 18x4     | ●    |
| 41699C18 | 18x4     | ●    |
| 41699B18 | 18x4     | ●    |



SS

**Bottle opener**

Levacapsule  
Flaschenöffner  
Décapsuleur  
Abrebotellas

art. 41699-12 dim. cm. 11x4



SS

**Bottle opener**

Levacapsule  
Flaschenöffner  
Décapsuleur  
Abrebotellas

art. 41699-04 dim. cm. 11x4



**Bar blade holster with belt clip**

Fondina per levacapsule  
Flaschenöffner-Halter  
Etui pour décapsuleur  
Funda para abrebotellas

art. 41699-13 dim. cm. 11x4



**Bottle opener, nickelplated**

Levacapsule nichelato  
Flaschenöffner, vernickelt  
Décapsuleur, nickelé  
Abrebotellas, niquelado

art. 41699-03



SS

E<sup>o</sup>dlund

**Can punch and bottle opener**

Apriscatole/levacapsule  
Dosen-/Flaschenöffner  
Ouvre-boîte/décapsuleur  
Abrelatas/botellas

art. 49860-00



B

**Tepokushi skewers**

Spiedini tepokushi  
Tepokushi Spieße  
Brochettes tepokushi  
Pinchos tepokushi

| art.     | l. cm. | pcs/pz |
|----------|--------|--------|
| 48300-43 | 9      | 100    |
| 48300-33 | 15     | 100    |



B

**Noshikushi skewers**

Spiedini noshikushi  
Noshikushi Spieße  
Brochettes noshikushi  
Pinchos noshikushi

art. 48300-42 l. cm. 10,5 pcs/pz 100







**W**

**Toothpicks**  
Stuzzicadenti  
Zahnstocher  
Cure-dents  
Palillos

| art.     | l. cm. | pcs/pz |
|----------|--------|--------|
| 48306-01 | 9      | 1000   |

**Birch, double pointed, individually wrapped.**  
Betulla, 2 punte, imbustati singolarmente.

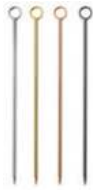

**SS**

**Cocktail picks, 4 pcs**  
Spiedini cocktail, 4 pz  
Cocktailspiese, 4 Stk  
Brochettes, 4 pièces  
Palos, 4 piezas

| art.     | l. cm. | col. |
|----------|--------|------|
| 41492-00 | 10     | ●    |
| 41492G00 | 10     | ●    |
| 41492C00 | 10     | ●    |
| 41492B00 | 10     | ●    |



**PC**

**Glass clip holder**  
Clip reggibicchiere  
Glashalter  
Clip porte-verre  
Soporte para vidrio

| art.     | U. Pack |
|----------|---------|
| 44048-99 | 100     |



**PS**

**Spits, disposable**  
Spiedini, monouso  
Fleischspieße, einweg  
Brochettes, usage unique  
Palos, desechables

| art.     | l. cm. | pcs/pz |
|----------|--------|--------|
| 48364-09 | 9      | 500    |
| 48364-12 | 12     | 500    |



**PS**

**Forks, disposable**  
Forchettine monouso  
Gabeln, einweg  
Fourchettes, usage unique  
Tenedores, desechables

| art.     | l. cm. | pcs/pz |
|----------|--------|--------|
| 48362-01 | 8,5    | 500    |



**PS**

**Spoons, disposable**  
Cucchiaini monouso  
Löffel, einweg  
Cuillères, usage unique  
Cucharitas, desechables

| art.     | l. cm. | pcs/pz |
|----------|--------|--------|
| 48363-01 | 8,5    | 500    |



# BAR HAPPY HOUR

APPETIZERS  
AMUSE-BOUCHE



SS

**Snack holder**  
Porta snack  
Snack-Behälter  
Conteneur à snack  
Contenedor para snack

| art.     | Ø cm. | h. cm. | lt.  |
|----------|-------|--------|------|
| 41524-09 | 9     | 8,5    | 0,33 |



SS

**Snack holder, 4 pcs**  
Porta snack, 4 pz  
Snack-Behälter, 4 Stk  
Conteneur à snack, 4 pcs  
Contenedor para snack, 4 pz

| art.     | Ø cm. | h. cm. | lt.  |
|----------|-------|--------|------|
| 41524-04 | 7     | 6,5    | 0,15 |



SS

**Snack holder**  
Porta snack  
Snack-Behälter  
Conteneur à snack  
Contenedor para snack

| art.     | dim. cm.   |
|----------|------------|
| 41527-12 | 10x8,5x6,5 |
| 41527-13 | 13x10,5x9  |



SS

**Snack holder**  
Porta snack  
Snack-Behälter  
Conteneur à snack  
Contenedor para snack

| art.     | dim. cm.      |
|----------|---------------|
| 41527-10 | 21,5x10,5x4,5 |
| 41527-11 | 26x13x5       |



SS

**Snack holder**  
Porta snack  
Snack-Behälter  
Conteneur à snack  
Contenedor para snack

| art.     | Ø cm. | h. cm. |
|----------|-------|--------|
| 41523-08 | 8     | 7,5    |
| 41523-09 | 9     | 8,5    |



SS

**Snack holder**  
Mini tegame  
Mini-Servierfanne  
Conteneur à snack  
Contenedor para snack

| art.     | dim. cm.     | lt. |
|----------|--------------|-----|
| 41522-14 | 14,5x9,5x4,5 | 0,5 |



SS  
PVD

**Snack holder**

Porta snack  
Snack-Behälter  
Conteneur à snack  
Contenedor para snack

| art.     | dim. cm.      | col. |
|----------|---------------|------|
| 41527G10 | 21,5x10,5x4,5 | ●    |
| 41527G11 | 26x13x5       | ●    |



SS  
PVD

**Snack holder**

Porta snack  
Snack-Behälter  
Conteneur à snack  
Contenedor para snack

| art.     | dim. cm.   | col. |
|----------|------------|------|
| 41527G12 | 10x8,5x6,5 | ●    |
| 41527G13 | 13x10,5x9  | ●    |



SS  
PVD

**Snack holder**

Porta snack  
Snack-Behälter  
Conteneur à snack  
Contenedor para snack

| art.     | Ø cm. | h. cm. | col. |
|----------|-------|--------|------|
| 41523G08 | 8     | 7,5    | ●    |
| 41523G09 | 9     | 8,5    | ●    |



SS

**Snack holder**

Porta snack  
Snack-Behälter  
Conteneur à snack  
Contenedor para snack

| art.     | Ø cm. | h. cm. | lt.  |
|----------|-------|--------|------|
| 41524-10 | 9,5   | 11,5   | 0,45 |



SS

**Snack holder**

Porta snack  
Snack-Behälter  
Conteneur à snack  
Contenedor para snack

| art.     | Ø cm. | h. cm. | lt.  |
|----------|-------|--------|------|
| 41524-11 | 8,5   | 8,5    | 0,35 |



SS

**Snack holder**

Porta snack  
Snack-Behälter  
Conteneur à snack  
Contenedor para snack

| art.     | Ø cm. | h. cm. | lt.  |
|----------|-------|--------|------|
| 41524-12 | 8,5   | 8,5    | 0,35 |



SS  
PVD

**Snack holder**

Porta snack  
Snack-Behälter  
Conteneur à snack  
Contenedor para snack

| art.     | Ø cm. | h. cm. | lt.  | col. |
|----------|-------|--------|------|------|
| 41524C10 | 9,5   | 11,5   | 0,45 | ●    |



SS  
PVD

**Snack holder**

Porta snack  
Snack-Behälter  
Conteneur à snack  
Contenedor para snack

| art.     | Ø cm. | h. cm. | lt.  | col. |
|----------|-------|--------|------|------|
| 41524C11 | 8,5   | 8,5    | 0,35 | ●    |



SS  
PVD

**Snack holder**

Porta snack  
Snack-Behälter  
Conteneur à snack  
Contenedor para snack

| art.     | Ø cm. | h. cm. | lt.  | col. |
|----------|-------|--------|------|------|
| 41524C12 | 8,5   | 8,5    | 0,35 | ●    |



W

**5 pcs tasting/dessert set**

Set 5 pz aperitivo/degustazione  
5 Stück Verkostung/Dessert Set  
Set 5 pcs dégustation/dessert  
Juego de degustación/postre 5 pz

| art.     | dim. cm.      | ml. |
|----------|---------------|-----|
| 41205-07 | 42x9x1,8 4x68 |     |



W

**4 pcs canning jar set**

Set 4 pz barattoli degustazione  
4 Stück Verkostung-Gläser Set  
Set 4 pcs dégustation/dessert  
Juego de degustación/postre 4 pz

| art.     | dim. cm.        | ml. |
|----------|-----------------|-----|
| 41205-08 | 27,5x11x4 3x200 |     |



W

**7 pcs canning jar set**

Set 7 pz barattoli degustazione  
5 Stück Verkostung-Gläser Set  
Set 7 pcs dégustation/dessert  
Juego de degustación/postre 5 pz

| art.     | dim. cm.      | ml. |
|----------|---------------|-----|
| 41205-09 | 43x10x3 6x100 |     |



**BAR HAPPY HOUR  
APPETIZERS AMUSE-BOUCHE**



**AR**

**5 pcs tasting/dessert set**

Set 5 pz aperitivo/degustazione

5 Stück Verkostung/Dessert Set

Set 5 pcs dégustation/dessert

Juego de degustación/postre 5 pz

art. dim. cm. ml.  
41205-01 35x10 4x43



**AR**

**5 pcs tasting/dessert set**

Set 5 pz aperitivo/degustazione

5 Stück Verkostung/Dessert Set

Set 5 pcs dégustation/dessert

Juego de degustación/postre 5 pz

art. dim. cm. ml.  
41205-02 35x10 4x110



**W**

**5 pcs tasting/dessert set**

Set 5 pz aperitivo/degustazione

5 Stück Verkostung/Dessert Set

Set 5 pcs dégustation/dessert

Juego de degustación/postre 5 pz

art. dim. cm. ml.  
41205-03 49x9,7x1,8 4x176



**W**

**4 pcs tasting/dessert set**

Set 4 pz aperitivo/degustazione

4 Stück Verkostung/Dessert Set

Set 4 pcs dégustation/dessert

Juego de degustación/postre 4 pz

art. dim. cm. ml.  
41205-04 35x11x1,8 3x147



**W**

**4 pcs tasting/dessert set**

Set 4 pz aperitivo/degustazione

4 Stück Verkostung/Dessert Set

Set 4 pcs dégustation/dessert

Juego de degustación/postre 4 pz

art. dim. cm. ml.  
41205-05 45x11x1,8 3x147



**W**

**5 pcs tasting/dessert set**

Set 5 pz aperitivo/degustazione

5 Stück Verkostung/Dessert Set

Set 5 pcs dégustation/dessert

Juego de degustación/postre 5 pz

art. dim. cm.  
41205-06 45x9x1,8



**W**

**4 pcs tasting/dessert set**

Set 4 pz aperitivo/degustazione

4 Stück Verkostung/Dessert Set

Set 4 pcs dégustation/dessert

Juego de degustación/postre 4 pz

art. dim. cm.  
41205-10 35x11x2



**W**

**7 pcs tasting/dessert set**

Set 7 pz aperitivo/degustazione

7 Stück Verkostung/Dessert Set

Set 7 pcs dégustation/dessert

Juego de degustación/postre 7 pz

art. dim. cm.  
41206-04 38x12x1





TRAYS  
VASSOI PLANK



In reinforced polyester, suitable for food contact, dishwasher safe. Natural rough finish and elegant at the same time. They can be used as showplate and as presentation tray as well. Available in 3 colors. Non-slip foot available on request item 41323-AA.

Plance in poliestere rinforzato, idoneo al contatto alimentare, lavabile in lavastoviglie. Finitura ruvida naturale ed elegante al tempo stesso. Possono essere utilizzate come piatto presentazione e come vassoi espositivi. Disponibili in 3 colorazioni. Piedini antiscivolo in opzione art. 41323-AA.



**Tray, rectangular**  
Plancia rettangolare  
Platte, rechteckig  
Plateau rectangulaire  
Placa rectangular

| art.     | dim. cm.  | col. |
|----------|-----------|------|
| 41323-11 | 30x20x0,5 | ●    |
| 41323-12 | 40x20x0,5 | ●    |
| 41323-13 | 40x30x0,5 | ●    |
| 41323-14 | 60x40x0,5 | ●    |



**Tray, rectangular**  
Plancia rettangolare  
Platte, rechteckig  
Plateau rectangulaire  
Placa rectangular

| art.     | dim. cm.  | col. |
|----------|-----------|------|
| 41323-21 | 30x20x0,5 | ●    |
| 41323-22 | 40x20x0,5 | ●    |
| 41323-23 | 40x30x0,5 | ●    |
| 41323-24 | 60x40x0,5 | ●    |



**Tray, rectangular**  
Plancia rettangolare  
Platte, rechteckig  
Plateau rectangulaire  
Placa rectangular

| art.     | dim. cm.  | col. |
|----------|-----------|------|
| 41323-01 | 30x20x0,5 | ●    |
| 41323-02 | 40x20x0,5 | ●    |
| 41323-03 | 40x30x0,5 | ●    |
| 41323-04 | 60x40x0,5 | ●    |



HDPE



**Tray support**  
Supporto per vassoi  
Tablett Unterstützung  
Support pour plateaux  
Soporte para bandejas

| art.     | dim. cm. | U. Pack |
|----------|----------|---------|
| 41323-99 | 5x5x6    | 24      |



TRAYS WOOD EFFECT  
VASSOI EFFETTO LEGNO



**Rectangular platter**  
Vassoio rettangolare  
Tablett, Rechteckig  
Plateau rectangulaire  
Bandeja rectangular

| art.     | dim. cm.      |
|----------|---------------|
| 44473-31 | 53x32,5x0,8   |
| 44473-32 | 32,5x26,5x0,8 |
| 44473-34 | 26x16x0,8     |
| 44473-33 | 32,5x17,5x0,8 |



**Round platter**  
Vassoio rotondo  
Tablett, Rund  
Plateau rond  
Bandeja redonda

| art.     | Ø cm. | h. cm. |
|----------|-------|--------|
| 44473-02 | 33    | 0,8    |
| 44473-03 | 43    | 0,8    |



**Round platter with handle**  
Vassoio rotondo con manico  
Tablett, Rund mit Griff  
Plateau rond avec manche  
Bandeja redonda con mango

| art.     | Ø cm. | h. cm. |
|----------|-------|--------|
| 44473-05 | 38    | 1,5    |



**Rectangular platter with handle**  
Vassoio rettangolare con manico  
Tablett Rechteckig mit Griff  
Plateau rectangulaire avec manche  
Bandeja rectangular con mango

| art.     | dim. cm.  |
|----------|-----------|
| 44473-07 | 53x20x1,5 |



**Rectangular platter with handle**  
Vassoio rettangolare con manico  
Tablett Rechteckig mit Griff  
Plateau rectangulaire avec manche  
Bandeja rectangular con mango

| art.     | dim. cm.  |
|----------|-----------|
| 44473-08 | 61x20x1,5 |



**Tray, rectangular**  
Plancia rettangolare  
Platte, rechteckig  
Plateau rectangulaire  
Placa rectangular

| art.     | dim. cm.      |
|----------|---------------|
| 44471-11 | 53x32,5x1,5   |
| 44471-12 | 32,5x26,5x1,5 |
| 44471-13 | 32,5x17,6x1,5 |
| 44471-14 | 26,5x16,2x1,5 |
| 44471-24 | 53x16,2x1,5   |





WOODEN SERVING BOARDS  
TAGLIERI IN LEGNO



Each piece is carefully handcrafted therefore size, shape and finish may vary from piece to piece. Wash by hand with warm soapy water, do not to soak.

Ogni pezzo è realizzato a mano quindi dimensioni, forma e finitura variano da pezzo a pezzo. Lavare a mano con acqua tiepida e sapone. Non mettere in ammollo.



Serving board  
Tagliere  
Servier-Brett  
Planche de service  
Tabla

| art.     | dim. cm. |
|----------|----------|
| 41327-01 | 45,5x20  |

Acacia wood. – Acacia.



Bowl  
Ciotola  
Schüssel  
Bol  
Bol

| art.     | Ø cm. |
|----------|-------|
| 41327-02 | 25,5  |

Acacia wood. – Acacia.



Serving board  
Tagliere  
Servier-Brett  
Planche de service  
Tabla

| art.     | Ø cm. |
|----------|-------|
| 41327-03 | 20,0  |
| 41327-04 | 25,5  |
| 41327-05 | 30,5  |

Acacia wood. – Acacia.



Serving board  
Tagliere  
Servier-Brett  
Planche de service  
Tabla

| art.     | Ø cm. |
|----------|-------|
| 41327-06 | 19,5  |
| 41327-07 | 24,0  |
| 41327-08 | 29,5  |

Acacia wood. – Acacia.



Serving board  
Tagliere  
Servier-Brett  
Planche de service  
Tabla

| art.     | Ø cm. |
|----------|-------|
| 41327-09 | 24    |
| 41327-10 | 30    |

Acacia wood. – Acacia.



Serving board  
Tagliere  
Servier-Brett  
Planche de service  
Tabla

| art.     | dim. cm.  |
|----------|-----------|
| 41320-25 | 25x17x1,5 |
| 41320-30 | 30x20,5x2 |
| 41320-35 | 35x24x2   |

Olive wood. – Ulivo.



W

**Serving board**  
Tagliere  
Servier-Brett  
Planche de service  
Tabla

| art.     | dim. cm.  | l.    |
|----------|-----------|-------|
| 41321-40 | 40x15x1,5 | 40+11 |
| 41321-44 | 44x20x2   | 44+12 |

Olive wood. – Ulivo.



W

**Serving board**  
Tagliere  
Servier-Brett  
Planche de service  
Tabla

| art.     | dim. cm.    | l.   |
|----------|-------------|------|
| 41322-19 | 19x12,2x1,5 | 19+6 |
| 41322-25 | 25x16x1,5   | 25+8 |
| 41322-31 | 31x20x1,5   | 31+9 |

Olive wood. – Ulivo.



W

**Serving board**  
Tagliere  
Servier-Brett  
Planche de service  
Tabla

| art.     | dim. cm. |
|----------|----------|
| 41325-20 | 20x12x3  |

Birch wood. – Betulla.



W

**Serving board**  
Tagliere  
Servier-Brett  
Planche de service  
Tabla

| art.     | dim. cm. |
|----------|----------|
| 41325-30 | 30x20x3  |

Birch wood. – Betulla.



W

**Serving board**  
Tagliere  
Servier-Brett  
Planche de service  
Tabla

| art.     | dim. cm. |
|----------|----------|
| 41325-40 | 40x15x3  |

Birch wood. – Betulla.



W

AR

**Serving board set 4 pieces**  
Tagliere set 4 pezzi  
Servier-Brett, 4-tlg  
Planche de service, set 4 pièces  
Tabla juego 4 piezas

| art.     | dim. cm.  |
|----------|-----------|
| 41206-01 | 35x23x1,5 |

Pine wood. – Pino.



W

AR

**Serving board set 3 pieces**  
Tagliere set 3 pezzi  
Servier-Brett, 3-tlg  
Planche de service, set 3 pièces  
Tabla juego 3 piezas

| art.     | dim. cm.  |
|----------|-----------|
| 41206-02 | 37x17x1,8 |

Pine wood. – Pino.



W

**Coffee set 4 pieces**  
Servizio caffè 4 pezzi  
Kaffeaset 4 Stk  
Service à café 4 pièces  
Servicio de café 4 piezas

| art.     | dim. cm.    |
|----------|-------------|
| 41206-03 | 25x18,7x2,5 |

Acacia wood. – Acacia.



AR

W

**Serving board**  
Tagliere  
Servier-Brett  
Planche de service  
Tabla

| art.     | dim. cm.    |
|----------|-------------|
| 41326-30 | 30,5x13x1,5 |

Acacia wood. – Acacia.



AR

W

**Serving board**  
Tagliere  
Servier-Brett  
Planche de service  
Tabla

| art.     | dim. cm.    |
|----------|-------------|
| 41326-36 | 36,5x15x1,5 |

Acacia wood. – Acacia.



AR

W

**Serving board**  
Tagliere  
Servier-Brett  
Planche de service  
Tabla

| art.     | dim. cm.  |
|----------|-----------|
| 41326-42 | 42x18x1,5 |

Acacia wood. – Acacia.





**W**  
**AR**

**Serving stand 2-tier**

Alzata 2 piani  
Servierstand 2-stufig  
Support 2 niveaux  
Soporte 2 pisos

art. dim. cm.  
41207-02 25x4,5x34,5

**Beech. Slate cm. 31x13 - 41x18.**  
Faggio. Ardesia cm. 31x13 - 41x18.



**W**  
**AR**

**Serving stand 3-tier**

Alzata 3 piani  
Servierstand 3-stufig  
Support 3 niveaux  
Soporte 3 pisos

art. dim. cm.  
41207-03 25x4,5x54

**Beech. Slate cm. 21x8 - 31x13 - 41x18.**  
Faggio. Ardesia cm. 21x8 - 31x13 - 41x18.



**W**

**Serving board with cast iron surface**

Tagliere con inserto ghisa  
Servierplatte mit Gusseiseneinsatz  
Planche à servir avec insert en fonte  
Tabla con inserto de hierro fundido

art. Ø cm. Por.  
44250S30 30 1-2

**Iroko wood.** – Iroko.



**W**

**Serving board with cast iron surface**

Tagliere con inserto ghisa  
Servierplatte mit Gusseiseneinsatz  
Planche à servir avec insert en fonte  
Tabla con inserto de hierro fundido

art. dim. cm. Por.  
44248S60 60x15x2,5 4

**Iroko wood.** – Iroko.



**W**

**Serving board with cast iron surface**

Tagliere con inserto ghisa  
Servierplatte mit Gusseiseneinsatz  
Planche à servir avec insert en fonte  
Tabla con inserto de hierro fundido

art. Ø cm. h. cm. Por.  
44254-30 31 2,5 1

**Iroko wood.** – Iroko.



**W**

**Wooden service platter**

Tagliere legno  
Holzbrett  
Planche à servir en bois  
Tabla madera

art. dim. cm. Por.  
44258-60 60x15 4-6

**Iroko wood.** – Iroko.



**W**

**Wooden service platter**

Tagliere legno  
Holzbrett  
Planche à servir en bois  
Tabla madera

art. dim. cm. Por.  
44264-35 25x35x1,8 1-2

**Iroko wood.** – Iroko.



**W**

**Wooden service platter**

Tagliere legno  
Holzbrett  
Planche à servir en bois  
Tabla madera

art. dim. cm. Por.  
44265-35 25x35x1,8 1-2

**Iroko wood.** – Iroko.



**W**

**Twice sauce pot wooden platter**

Porta coppette doppio  
Schale-Träger doppel  
Support à bol double  
Soporte copa doble

art. Ø cm. dim. cm.  
44256-02 5,5 8x20x1,8

**Beechwood.** – Faggio.



**W**

**Triple sauce pot wooden platter**

Porta coppette triplo  
Schale-Träger dreifach  
Support à bol triple  
Soporte copa triple

art. Ø cm. dim. cm.  
44256-03 5,5 8x28x1,8

**Beechwood.** – Faggio.



**W**

**Quartet sauce pot wooden platter**

Porta coppette quadruplo  
Schale-Träger vierfach  
Support à bol quadruple  
Soporte copa cuatro veces

art. Ø cm. dim. cm.  
44256-04 5,5 8x36x1,8

**Beechwood.** – Faggio.



MF

**Bowl**  
Ciotola  
Schale  
Bol  
Bol

| art.     | Ø cm. | h. cm. | lt.  |
|----------|-------|--------|------|
| 44846B05 | 5,5   | 4      | 0,02 |



MF

**Bowl**  
Ciotola  
Schale  
Bol  
Bol

| art.     | dim. cm.  | lt.  |
|----------|-----------|------|
| 44466-11 | 7,5x7x4,5 | 0,05 |



MF

**Bowl**  
Ciotola  
Schale  
Bol  
Bol

| art.     | dim. cm.   | lt.  |
|----------|------------|------|
| 44466-12 | 11,5x7,5x3 | 0,06 |



MF

**Bowl**  
Ciotola  
Schale  
Bol  
Bol

| art.     | dim. cm.   | lt.  |
|----------|------------|------|
| 44466-13 | 11,5x6x5,5 | 0,04 |



MF

**Bowl**  
Ciotola  
Schale  
Bol  
Bol

| art.     | dim. cm. | lt.  |
|----------|----------|------|
| 44466-14 | 8,5x7x6  | 0,07 |



MF

**Bowl**  
Ciotola  
Schale  
Bol  
Bol

| art.     | dim. cm. | lt. |
|----------|----------|-----|
| 44466-15 | 8x8x4    | 0,1 |

NATURAL ELEGANT



A valid alternative to glass. Elegant and unbreakable ideal for HORECA pastry and ice cream sector. Made with high quality material that confers beside resistance also glossiness and perfect transparency. Bisphenol free. Thermal tolerance -18°C +70°C. 100% recyclable material. Dishwasher safe: up to 50 washes. Made in Italy.

La valida alternativa al vetro. Eleganti ed infrangibili ideali per il settore HORECA della pasticceria e gelateria. Realizzati con materiale di alta qualità che gli conferisce oltre alla resistenza anche lucidità e trasparenza. Privi di Bisfenolo. Tolleranza termica -18°C +70°C. Materiale riciclabile al 100%. Lavabili in lavastoviglie: fino a 50 lavaggi. Prodotti made in Italy.



PS

**Tasting glass**  
Bicchierino degustazione  
Verkostung Glas  
Verrine dégustation  
Vaso degustación

| art.     | dim. cm. | h. cm. | ml. |
|----------|----------|--------|-----|
| 48368-05 | 6,4x4,6  | 5,3    | 50  |
| 48368-12 | 8,5x6    | 7,0    | 120 |
| 48368-20 | 10x7     | 8,2    | 200 |

Set 100 pcs. – Conf. 100 pz.



PS

**Tasting glass**  
Bicchierino degustazione  
Verkostung Glas  
Verrine dégustation  
Vaso degustación

| art.     | dim. cm. | h. cm. | ml. |
|----------|----------|--------|-----|
| 48369-08 | 6,3x6,9  | 5,7    | 85  |
| 48369-14 | 7,3x8,1  | 6,7    | 140 |
| 48369-20 | 9x8,3    | 7,4    | 200 |

Set 100 pcs. – Conf. 100 pz.



PS

**Tasting dish**

Piattino degustazione  
Verkostung Teller  
Assiette dégustation  
Platillo degustación

art. Ø cm.

48372-08 8

**Set 100 pcs. – Conf. 100 pz.**



PS

**Tasting bowl**

Ciotolina degustazione  
Verkostung Schale  
Bol dégustation  
Bol degustación

art. Ø cm. ml.

48359-01 6,5 15

**Set 100 pcs. – Conf. 100 pz.**



PS

**Tasting glass**

Bicchierino degustazione  
Verkostung Glas  
Verrine dégustation  
Vaso degustación

art. Ø cm. h. cm. ml.

48354-01 4 8,5 70

**Set 100 pcs. – Conf. 100 pz.**



PS

**Tasting bowl**

Ciotolina degustazione  
Verkostung Schale  
Bol dégustation  
Bol degustación

art. Ø cm. ml.

48357-01 7,5 50

**Set 100 pcs. – Conf. 100 pz.**



PS

**Tasting glass**

Bicchierino degustazione  
Verkostung Glas  
Verrine dégustation  
Vaso degustación

art. Ø cm. h. cm. ml.

48353-01 8,5 6,5 120

**Set 100 pcs. – Conf. 100 pz.**



PS

**Tasting dish**

Piattino degustazione  
Verkostung Teller  
Assiette dégustation  
Platillo degustación

art. Ø cm. h. cm. ml.

48355-01 9 1,5 20

**Set 100 pcs. – Conf. 100 pz.**



PS

**Tasting bowl**

Ciotolina degustazione  
Verkostung Schale  
Bol dégustation  
Bol degustación

art. dim. cm. ml.

48358-01 10,5x5x3 11

**Set 100 pcs. – Conf. 100 pz.**



PS

**Tasting bowl**

Ciotolina degustazione  
Verkostung Schale  
Bol dégustation  
Bol degustación

art. Ø cm. ml.

48356-01 8,5 30

**Set 100 pcs. – Conf. 100 pz.**

FINGERFOOD



**Oval tweested dish**  
Ovalina goccia

art. dim. cm.  
41200-01 9x5x3



**Eye dish**  
Ovalina occhio

art. dim. cm.  
41200-02 8,1x5,6x3



**Egg dish**  
Tegamino 2/m

art. dim. cm.  
41200-03 8,5x6,8x2



**Oval dish**  
Ovalina

art. dim. cm.  
41200-04 10x5,5x2,7



**Soya sauce dish**  
Rettangolare

art. dim. cm.  
41200-05 8x5,5x1,8



**Square dish**  
Piattino quadro

art. dim. cm.  
41200-06 8x8x2,4



**Oriental square dish**  
Quadrato orientale

art. dim. cm.  
41200-07 7,5x7,5x3



**Dye dish**  
Cubo

art. dim. cm.  
41200-08 5,2x5,2x4



**Chao dish**  
Quadrato punte

art. dim. cm.  
41200-09 8x8x5



**Tear dish**  
Foglia

art. dim. cm.  
41200-10 8x7x3,4



**Nem dish**  
Tronchetto

art. dim. cm.  
41200-11 5,5x4,5x6,5



**Rectangular w/lid**  
Rettangolare c/cop

art. dim. cm.  
41200-13 10x5,5x4,5



**Square pan with lid**  
Quadra c/cop

art. dim. cm.  
41200-14 9x3,6x4,5



**Oval pan with lid**  
Ovale c/cop

art. dim. cm.  
41200-15 10,5x7x4,5



**Rectangular pan**  
Casseruola rett.

art. dim. cm.  
41200-16 10x5,5x4,5



**Square pan**  
Casseruola quadra

art. dim. cm.  
41200-17 9x3,6x4,5







**Oval pan**  
Casseruola ovale

art. dim. cm.  
41200-18 10,5x7x4,5



**Footed square dish**  
Quadrato

art. dim. cm.  
41200-32 10x10x1,2



**Fish dish**  
Piattino pesce

art. dim. cm.  
41200-33 10,5x5x1,6



**Small pan**  
Tegamino

art. dim. cm.  
41200-34 9,7x6x2,6



**Mini pasta bowl**  
Mini ciotola pasta

art. dim. cm.  
41200-36 10x2,5x1,6



**Square dish**  
Coppetta quadra

art. dim. cm.  
41200-40 7x7x3,5



**Round bowl**  
Bolo tondo

art. Ø cm. h. cm.  
41200-41 7 4,5



**Small pot**  
Mini pentola

art. dim. cm.  
41200-49 5x5x5



**Small bucket**  
Secchiello

art. dim. cm.  
41200-50 6x6x4,5



**Colander**  
Colapasta

art. dim. cm.  
41200-51 7x7x4,5



**Fruit case**  
Cassetta frutta

art. dim. cm.  
41200-52 8x5,5x2,3



**Tin with lid**  
Scatoletta c/cop

art. dim. cm.  
41200-53 13,5x5,5x5



**Tin with lid**  
Scatoletta c/cop

art. Ø cm. h. cm.  
41200-54 13,5 4



**French fries bowl**  
Vaschetta patatine

art. dim. cm.  
41200-58 13x10x4



**Rectangular w/handles**  
Rettangolare c/m

art. dim. cm.  
41200-59 14x10x3,5



**Rectangular lid**  
Coperchio rett.

art. dim. cm.  
41200-60 14x10



**Oval w/handles**  
Ovale c/m

art. dim. cm.  
41200-61 14x9,5x3,5



**Oval lid**  
Coperchio ovale

art. dim. cm.  
41200-62 14x9,5



**Round w/handles**  
Tonda c/m

art. Ø cm. h. cm.  
41200-63 13 5,5



**Round lid**  
Coperchio tondo

art. Ø cm.  
41200-64 13



**Ramequin**  
Ramequin

art. Ø cm. h. cm.  
41200-46 10 5,0  
41200-47 9 5,0  
41200-48 8 4,5



**Vintage tray**  
Vassoietto vintage

art. dim. cm.  
41200-55 15x10x1,7



**Vintage tray**  
Vassoietto vintage

art. dim. cm.  
41200-56 22,3x14x2



**Vintage tray**  
Vassoietto vintage

art. dim. cm.  
41200-57 29,5x20,5x2

# TABLE TOP TAVOLA

SERVING ITEMS  
COMPLEMENTI

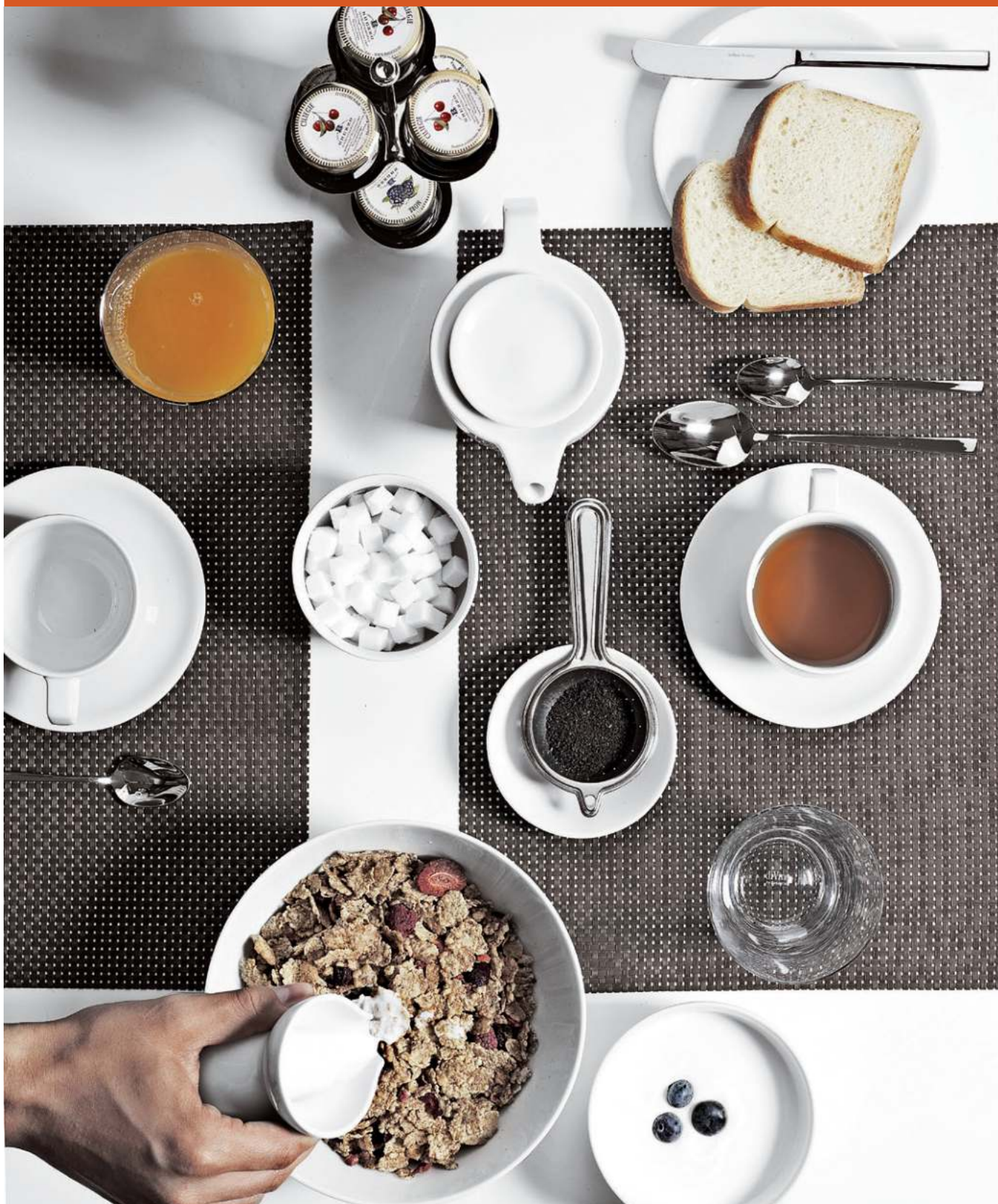



TABLE MATS & RUNNERS



Material: 50% polyester - 50% Polyvinyl chloride

Materiale: 50% Poliестere - 50% Cloruro di polivinile



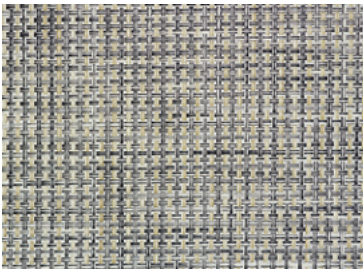

**Table mat - Light melange**

Tovaglietta - Melange chiaro

| art.     | dim. cm. | pcs/pz |
|----------|----------|--------|
| 42950-01 | 42x33    | 6      |



**Table mat - Brown**

Tovaglietta - Marrone

| art.     | dim. cm. | pcs/pz |
|----------|----------|--------|
| 42950-04 | 42x33    | 6      |

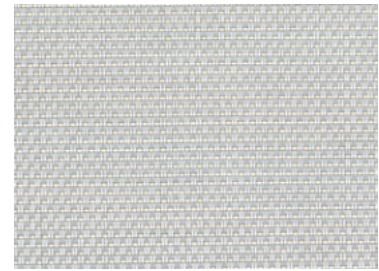

**Table mat - Crispy**

Tovaglietta - Croccante

| art.     | dim. cm. | pcs/pz |
|----------|----------|--------|
| 42950-07 | 42x33    | 6      |

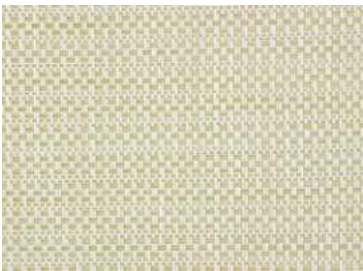

**Table mat - Sandy**

Tovaglietta - Beige

| art.     | dim. cm. | pcs/pz |
|----------|----------|--------|
| 42950-02 | 42x33    | 6      |



**Table mat - Beige-Grey**

Tovaglietta - Beige-Grigio

| art.     | dim. cm. | pcs/pz |
|----------|----------|--------|
| 42950-05 | 42x33    | 6      |



**Table mat - Coral**

Tovaglietta - Corallo

| art.     | dim. cm. | pcs/pz |
|----------|----------|--------|
| 42950-08 | 42x33    | 6      |

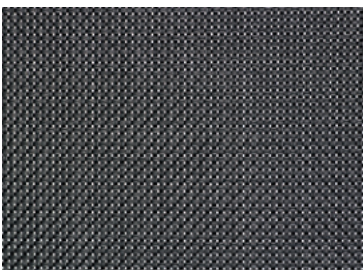

**Table mat - Black**

Tovaglietta - Nero

| art.     | dim. cm. | pcs/pz |
|----------|----------|--------|
| 42950-03 | 42x33    | 6      |

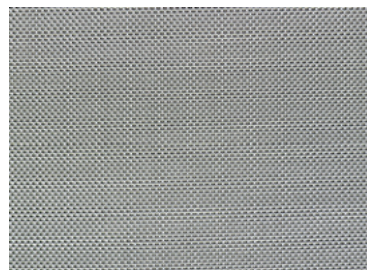

**Table mat - Grey**

Tovaglietta - Grigio

| art.     | dim. cm. | pcs/pz |
|----------|----------|--------|
| 42950-06 | 42x33    | 6      |

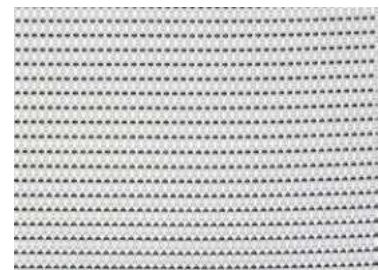

**Table mat - White pin-striped**

Tovaglietta - Gessato bianco

| art.     | dim. cm. | pcs/pz |
|----------|----------|--------|
| 42950-09 | 42x33    | 6      |

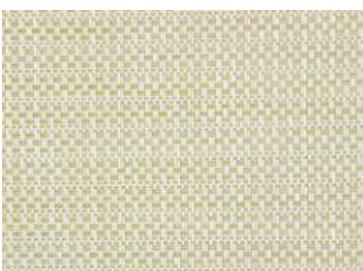

**RUNNER - Sandy  
Beige**

| art.     | dim. cm. |
|----------|----------|
| 42950-92 | 42x180   |

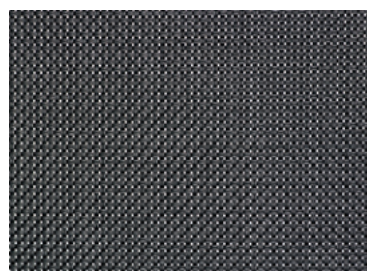

**RUNNER - Black  
Nero**

| art.     | dim. cm. |
|----------|----------|
| 42950-93 | 42x180   |



**RUNNER - Brown  
Marrone**

| art.     | dim. cm. |
|----------|----------|
| 42950-94 | 42x180   |





NATURAL SLATE  
ARDESIA NATURALE



Excellent coldness retention, food safe. The edges of the trays are broken to show the typical structure of the natural material. With anti-slip feet. No dishwasher proof. Material thickness: 4-7 mm.

Eccellente immagazzinamento del freddo, idonei al contatto alimentare. Gli angoli dei piani sono spezzati per evidenziare la tipica struttura del materiale. Con piedini antiscivolo. Non idonei al lavaggio in lavastoviglie. Spessore: 4-7 mm.



**Tray**  
Vassoio  
Platte  
Plateau  
Placa

| art.     | dim. cm. |
|----------|----------|
| 41585-37 | 20x10    |



**Tray**  
Plancia  
Platte  
Plateau  
Placa

| art.     | GN  | dim. cm.  |
|----------|-----|-----------|
| 41585-11 | 1/1 | 53x32,2   |
| 41585-12 | 1/2 | 32,5x26,5 |
| 41585-13 | 1/3 | 32,5x17,5 |
| 41585-24 | 1/4 | 26,5x16,5 |
| 41585-23 | 2/4 | 53x16,2   |



**Square tray**  
Plancia quadra  
Platte, viereckig  
Plateau carré  
Placa cuadrada

| art.     | dim. cm. |
|----------|----------|
| 41585-25 | 25x25    |
| 41585-30 | 30x30    |



**Rectangulat tray**

Plancia rettangolare  
Platte, rechteckig  
Plateau rectangulaire  
Placa rectangular

| art.     | dim. cm. |
|----------|----------|
| 41585-45 | 45x30    |



**Round tray**

Plancia tonda  
Platte, rund  
Plaque ronde  
Placa redonda

| art.     | Ø cm. |
|----------|-------|
| 41586-22 | 22    |
| 41586-28 | 28    |
| 41586-33 | 33    |
| 41586-38 | 38    |



**Square tray, 4 pcs set**

Plancia quadra, set 4 pz  
Platte, viereckig, Satz 4 Stk  
Plateau carré, set 4 pcs  
Placa cuadrada, juego 4 pz

| art.     | dim. cm. |
|----------|----------|
| 41585-10 | 10x10    |



**Tray with holes**

Vassoio con fori  
Platte mit Absätze  
Plat avec trous  
Placa con agujeros

| art.     | Ø cm. | dim. cm. |
|----------|-------|----------|
| 41585-01 | 6     | 25x12    |



**Tray with holes**

Vassoio con fori  
Platte mit Absätze  
Plat avec trous  
Placa con agujeros

| art.     | Ø cm. | dim. cm. |
|----------|-------|----------|
| 41585-02 | 6     | 15x8     |



**Tray with holes**

Vassoio con fori  
Platte mit Absätze  
Plat avec trous  
Placa con agujeros

| art.     | Ø cm. | dim. cm. |
|----------|-------|----------|
| 41585-03 | 6     | 28x10    |



**Tray with dome**

Piatto con campana  
Platte mit Glashaube  
Plat avec cloche  
Bandeja y campana

| art.     | Ø cm. | h. cm. |
|----------|-------|--------|
| 41585-00 | 10,5  | 8      |



**Tray 2-tier**

Alzata 2 piani  
Etagère 2-stufig  
Présentoir 2 niveaux  
Bandeja 2 niveles

| art.     | Ø cm. | h. cm. |
|----------|-------|--------|
| 41587-25 | 20-25 | 24     |



**Revolving platter**

Supporto girevole  
Servierplatt, drehbar  
Présentoir tournant  
Soporte rotatorio

| art.     | Ø cm. | h. cm. |
|----------|-------|--------|
| 41587-32 | 32    | 2,5    |



**Tray**

Plancia  
Platte  
Plateau  
Placa

| art.     | dim. cm.  | fits/per |
|----------|-----------|----------|
| 41585-51 | 24x15     | 44842-30 |
| 41585-52 | 47x10     | 44843-24 |
| 41585-53 | 26,5x20,5 | 44843-12 |
| 41585-54 | 32x12     | 44842-35 |

41585-52 + 44843-24



41585-54 + 44842-35



41585-53 + 44843-12



41585-51 + 44842-30



BLACK & BROWN  
NERO & MARRONE



The rough surface structure creates a natural appearance. The black bowls and trays with brown border stage your dishes in a very stylish way.

La struttura superficiale ruvida crea un aspetto naturale. Le ciotole e i vassoi neri con bordo marrone mettono in scena le pietanze in modo molto elegante.



**Bowl**  
Ciotola  
Schüssel  
Bol  
Bol

| art.     | Ø cm. | h. cm. | lt. |
|----------|-------|--------|-----|
| 44480-10 | 14    | 6,0    | 0,3 |
| 44480-11 | 19    | 8,0    | 0,8 |
| 44480-12 | 21    | 8,5    | 1,0 |
| 44480-13 | 24    | 9,5    | 1,4 |



**Bowl**  
Ciotola  
Schüssel  
Bol  
Bol

| art.     | Ø cm. | h. cm. | lt.  |
|----------|-------|--------|------|
| 44480-15 | 11    | 3,5    | 0,13 |
| 44480-16 | 14    | 4,0    | 0,20 |
| 44480-20 | 30,5  | 8,5    | 2,00 |



**Bowl**  
Ciotola  
Schüssel  
Bol  
Bol

| art.     | dim. cm.      | lt. |
|----------|---------------|-----|
| 44480-14 | 23,5x23,5x6,5 | 0,7 |



**Tray**  
Vassoio  
Tablett  
Plateau  
Bandeja

| art.     | dim. cm.    |
|----------|-------------|
| 44480-03 | 14,5x14,5x2 |



**Tray**  
Vassoio  
Tablett  
Plateau  
Bandeja

| art.     | dim. cm.    |
|----------|-------------|
| 44480-06 | 26,5x16,5x4 |



**Bowl**  
Ciotola  
Schüssel  
Bol  
Bol

| art.     | Ø cm. | h. cm. | lt.  |
|----------|-------|--------|------|
| 44480-07 | 8,5   | 2,5    | 0,05 |



**Bowl**  
Ciotola  
Schüssel  
Bol  
Bol

| art.     | Ø cm. | h. cm. | lt.  |
|----------|-------|--------|------|
| 44480-08 | 11,5  | 3      | 0,04 |



**Bowl**  
Ciotola  
Schüssel  
Bol  
Bol

| art.     | Ø cm. | h. cm. | lt. |
|----------|-------|--------|-----|
| 44480-09 | 11    | 5,5    | 0,2 |



**Tray**  
Vassoio  
Tablett  
Plateau  
Bandeja

| art.     | dim. cm.      |
|----------|---------------|
| 44480-19 | 32,5x23,5x4,5 |



**Bowl**

Ciotola  
Schüssel  
Bol

| art.     | dim. cm.    | lt. |
|----------|-------------|-----|
| 44480-00 | 25,5x14x5,5 | 0,4 |
| 44480-01 | 36x19x8     | 0,9 |

**Tray**

Vassoio  
Tablett  
Plateau  
Bandeja

| art.     | dim. cm.  |
|----------|-----------|
| 44480-04 | 22,5x15x3 |
| 44480-05 | 27,5x11x2 |

**Tray**

Vassoio  
Tablett  
Plateau  
Bandeja

| art.     | dim. cm.   |
|----------|------------|
| 44480-17 | 19,5x9,5x2 |
| 44480-18 | 39x16x3    |

## CLAY ARGILLA



Serving and buffet items, an imitation of clay, either white with brown border or dark brown with terracotta border. The surface is inside and outside fine-matt. Feels like real clay.

Piatti da servizio e buffet, un'imitazione dell'argilla, sia bianchi con bordo marrone o moro con bordo terracotta. La superficie interna ed esterna è finemente opaca. Effetto argilla anche al tatto.

**Soup plate**

Piatto fondo  
Teller tief  
Assiette creuse  
Plato hondo

| art.     | Ø cm. | h. cm. | lt. | col. |
|----------|-------|--------|-----|------|
| 44478-20 | 20,5  | 3      | 0,5 | ●    |

**Soup plate**

Piatto fondo  
Teller tief  
Assiette creuse  
Plato hondo

| art.     | Ø cm. | h. cm. | lt. | col. |
|----------|-------|--------|-----|------|
| 44478-21 | 20,5  | 3      | 0,5 | ●    |

**Flat plate**

Piatto piano  
Teller flach  
Assiette plate  
Plato llano

| art.     | dim. cm.  | col. |
|----------|-----------|------|
| 44478-22 | 14x13x2,5 | ●    |





**Flat plate**  
Piatto piano  
Teller flach  
Assiette plate  
Plato llano

| art.     | dim. cm.  | col. |
|----------|-----------|------|
| 44478-23 | 14x13x2,5 | ●    |



**Bowl**  
Ciotola  
Schüssel  
Bol

| art.     | Ø cm. | h. cm. | lt.  | col. |
|----------|-------|--------|------|------|
| 44478-24 | 12,5  | 6      | 0,37 | ●    |
| 44478-26 | 16    | 7      | 0,70 | ●    |



**Bowl**  
Ciotola  
Schüssel  
Bol

| art.     | Ø cm. | h. cm. | lt.  | col. |
|----------|-------|--------|------|------|
| 44478-25 | 12,5  | 6      | 0,37 | ●    |
| 44478-27 | 16    | 7      | 0,70 | ●    |



**Bowl**  
Ciotola  
Schüssel  
Bol  
Bol

| art.     | Ø cm. | h. cm. | lt. | col. |
|----------|-------|--------|-----|------|
| 44478-28 | 16,5  | 4      | 0,5 | ●    |



**Bowl**  
Ciotola  
Schüssel  
Bol  
Bol

| art.     | Ø cm. | h. cm. | lt. | col. |
|----------|-------|--------|-----|------|
| 44478-29 | 16,5  | 4      | 0,5 | ●    |



**Bowl**  
Ciotola  
Schüssel  
Bol  
Bol

| art.     | Ø cm. | h. cm. | lt.  | col. |
|----------|-------|--------|------|------|
| 44478-30 | 21    | 8      | 1,45 | ●    |



**Bowl**  
Ciotola  
Schüssel  
Bol  
Bol

| art.     | Ø cm. | h. cm. | lt.  | col. |
|----------|-------|--------|------|------|
| 44478-31 | 21    | 8      | 1,45 | ●    |



**Bowl**  
Ciotola  
Schüssel  
Bol  
Bol

| art.     | dim. cm.    | lt.  | col. |
|----------|-------------|------|------|
| 44478-32 | 30,5x10x7,5 | 0,17 | ●    |
| 44478-34 | 42x14x9,5   | 0,65 | ●    |



**Bowl**  
Ciotola  
Schüssel  
Bol  
Bol

| art.     | dim. cm.    | lt.  | col. |
|----------|-------------|------|------|
| 44478-33 | 30,5x10x7,5 | 0,17 | ●    |
| 44478-35 | 42x14x9,5   | 0,65 | ●    |



**Serving box 7 pieces**

Servizio pranzo 7 pezzi  
Servierbox 7 Stück  
Boîte repas 7 pièces  
Caja comida 7 piezas

| art.     | dim. cm. |
|----------|----------|
| 44357-07 | 30x25x8  |

**For indoor & outdoor use. Perfect for room, pool and beach service. Set consisting of 1 box + 1 cover, 1 large bowl cm 23x14x6 Lt 1,4 - 1 medium bowl cm 14x11,5x6 Lt 0,6 - 2 small bowls cm 11,5x7x6 Lt 0,25 - 1 non-slip mat cm 26x21. Cover and box in wooden look, inside white.**

Per uso interno ed esterno. Perfetto per servizio in camera, piscina e spiaggia. Set composto da 1 box + 1 coperchio, 1 ciotola grande cm 23x14x6 Lt 1,4 - 1 ciotola media cm 14x11,5x6 Lt 0,6 - 2 ciotole piccole cm 11,5x7x6 Lt 0,25 - 1 tappetino antiscivolo cm 26x21. Coperchio e box effetto legno, interno bianco.

**NEW**

**MF**



GLASS JARS  
VASETTI WECK

Perfect for the sterilization and pasteurization of any product, fruit, vegetables, but also meat, fish, foie gras or delicatessen products. They are suitable for serving jams and sauces: they also look beautiful on the table. They are perfect for cooking and serving on the table. They are 100% pure glass, so they do not release harmful substances into food, they resist very high temperatures (up to 200°C in the oven), they can be washed in the dishwasher (including seal).

Perfetti per la sterilizzazione e la pastorizzazione di qualsiasi prodotto, di frutta verdura ma anche di carne, pesce, foie gras o prodotti di salumeria. Sono indicati per servire marmellate e salse di accompagnamento: inoltre belli da vedere sulla tavola. Sono i vasetti perfetti per la vasocottura e per servire in tavola. Sono al 100% in puro vetro, quindi non rilasciano sostanze nocive nel cibo, resistono a temperature elevatissime (fino a 200°C in forno), si possono lavare in lavastoviglie (guarnizione compresa).



**Glasses with cover, 12 pcs**  
Vasetti con coperchio, 12 pz  
Gläser mit Deckel, 12er Set  
Verres avec couvercle, 12 pcs  
Vasos con tapa, 12 pz

| art.     | Ø cm. | h. cm. | ml. |
|----------|-------|--------|-----|
| 41589-08 | 6     | 5,5    | 80  |
| 41589-14 | 6     | 7,0    | 140 |



**Glasses with cover, 12 pcs**  
Vasetti con coperchio, 12 pz  
Gläser mit Deckel, 12er Set  
Verres avec couvercle, 12 pcs  
Vasos con tapa, 12 pz

| art.     | Ø cm. | h. cm. | ml. |
|----------|-------|--------|-----|
| 41589-16 | 6     | 8      | 160 |



**Glasses with cover, 12 pcs**  
Vasetti con coperchio, 12 pz  
Gläser mit Deckel, 12er Set  
Verres avec couvercle, 12 pcs  
Vasos con tapa, 12 pz

| art.     | Ø cm. | h. cm. | ml. |
|----------|-------|--------|-----|
| 41589-20 | 9     | 6      | 200 |



**Glasses with cover, 12 pcs**  
Vasetti con coperchio, 12 pz  
Gläser mit Deckel, 12er Set  
Verres avec couvercle, 12 pcs  
Vasos con tapa, 12 pz

| art.     | Ø cm. | h. cm. | ml. |
|----------|-------|--------|-----|
| 41589-22 | 7     | 8      | 220 |



**NEW**

**Glasses with cover, 12 pcs**  
Vasetti con coperchio, 12 pz  
Gläser mit Deckel, 12er Set  
Verres avec couvercle, 12 pcs  
Vasos con tapa, 12 pz

| art.     | Ø cm. | h. cm. | ml. |
|----------|-------|--------|-----|
| 41589-07 | 5,5   | 6      | 75  |



**NEW**

**Glasses with cover, 12 pcs**  
Vasetti con coperchio, 12 pz  
Gläser mit Deckel, 12er Set  
Verres avec couvercle, 12 pcs  
Vasos con tapa, 12 pz

| art.     | Ø cm. | h. cm. | ml. |
|----------|-------|--------|-----|
| 41589-15 | 5,5   | 9      | 145 |



**NEW**

**Glasses with cover, 6 pcs**  
Vasetti con coperchio, 6 pz  
Gläser mit Deckel, 6er Set  
Verres avec couvercle, 6 pcs  
Vasos con tapa, 6 pz

| art.     | Ø cm. | h. cm. | ml. |
|----------|-------|--------|-----|
| 41589-29 | 9     | 9      | 290 |



**NEW**

**Glasses with cover, 6 pcs**  
Vasetti con coperchio, 6 pz  
Gläser mit Deckel, 6er Set  
Verres avec couvercle, 6 pcs  
Vasos con tapa, 6 pz

| art.     | Ø cm. | h. cm. | ml. |
|----------|-------|--------|-----|
| 41589-59 | 11    | 9      | 580 |



**Glasses with cover, 2 pcs**  
Vasetti con coperchio, 2 pz  
Gläser mit Deckel, 2er Set  
Verres avec couvercle, 2 pcs  
Vasos con tapa, 2 pz

| art.     | Ø cm. | h. cm. | ml. |
|----------|-------|--------|-----|
| 41589-58 | 11    | 11     | 580 |



**Glasses with cover, 3 pcs**  
Vasetti con coperchio, 3 pz  
Gläser mit Deckel, 3er Set  
Verres avec couvercle, 3 pcs  
Vasos con tapa, 3 pz

| art.     | Ø cm. | h. cm. | ml. |
|----------|-------|--------|-----|
| 41589-37 | 11    | 7,5    | 370 |



**Bottles with cover, 6 pcs**  
Bottigliette con coperchio, 6 pz  
Flaschen mit Deckel, 6er Set  
Bouteilles avec couvercle, 6 pcs  
Botellas con tapa, 6 pz

| art.     | Ø cm. | h. cm. | ml. |
|----------|-------|--------|-----|
| 41589-25 | 6,5   | 14,5   | 250 |



**Bottles with cover, 6 pcs**  
Bottigliette con coperchio, 6 pz  
Flaschen mit Deckel, 6er Set  
Bouteilles avec couvercle, 6 pcs  
Botellas con tapa, 6 pz

| art.     | Ø cm. | h. cm. | ml. |
|----------|-------|--------|-----|
| 41589-50 | 6,5   | 19     | 500 |



**Bottles with cover, 6 pcs**  
Bottigliette con coperchio, 6 pz  
Flaschen mit Deckel, 6er Set  
Bouteilles avec couvercle, 6 pcs  
Botellas con tapa, 6 pz

| art.     | Ø cm. | h. cm. | ml.  |
|----------|-------|--------|------|
| 41589-99 | 6,5   | 25,5   | 1000 |





**Rubber rings, 10 pcs**

Guarnizioni, 10 pz  
Gummidichtringe, 10er Set  
Joints, 10 pièces  
Juntas, 10 piezas

| art.     | Ø cm. | fits/per |
|----------|-------|----------|
| 41589-AA | 6     | 08/14/16 |
| 41589-BB | 9     | 20/29    |
| 41589-CC | 11    | 37/58/59 |



**Airtight covers, 5 pcs**

Coperchi ermetici, 5 pz  
Frischhaltedeckel, 5er Set  
Couvercles hermétiques, 5 pz  
Tapas herméticas, 5 pz

| art.     | fits/per             |
|----------|----------------------|
| 41589-AC | 08/14/16<br>25/50/99 |



**Cover clamps, 8 pcs**

Clip, 8 pezzi  
Deckel-Klammer, 8er Set  
Clips crochets, 8 pcs  
Abrazaderas, 8 pz

| art.     |
|----------|
| 41589-AB |

SS



**Glasses (without lid), 12 pcs**

Vasetti (senza coperchi), 12 pz  
Gläser (ohne Deckel), 12er Set  
Verres (sans couvercle), 12 pcs  
Vasos (sin tapa), 12 pz

| art.     | Ø cm. | h. cm. | ml. |
|----------|-------|--------|-----|
| 41589C08 | 6     | 5,5    | 80  |
| 41589C16 | 6     | 8      | 160 |



**Serving stand, chrome plated**

Supporto cromato  
Serviergestell, hartverchromt  
Présentoir, acier chromé  
Soporte, acero cromado

| art.     | Ø cm. | h. | fits/per |
|----------|-------|----|----------|
| 44840-28 | 22    | 33 | 41589-08 |

Without glasses. – Senza vasetti.



**Serving stand, chrome plated**

Supporto cromato  
Serviergestell, hartverchromt  
Présentoir, acier chromé  
Soporte, acero cromado

| art.     | Ø cm. | h. | fits/per       |
|----------|-------|----|----------------|
| 44840-27 | 22    | 59 | 41589-08/14/16 |

Without glasses. – Senza vasetti.



SS

**Insulated beverage server**

Caraffa termica  
Thermokanne  
Pot isotherme  
Jarra térmica

| art.     | lt. |
|----------|-----|
| 41650-06 | 0,6 |
| 41650-10 | 1,0 |
| 41650-13 | 1,5 |



SS

**Insulated beverage server**

Caraffa termica  
Thermokanne  
Pot isotherme  
Jarra térmica

| art.     | lt.  |
|----------|------|
| 41646-06 | 0,75 |
| 41646-10 | 1,00 |
| 41646-15 | 1,50 |
| 41646-20 | 2,00 |



SS

**Insulated beverage server**

Caraffa termica  
Thermokanne  
Pot isotherme  
Jarra térmica

| art.     | lt. |
|----------|-----|
| 42401-10 | 1,0 |
| 42401-15 | 1,5 |
| 42401-20 | 2,0 |





SS

**Insulated beverage server**

Caraffa termica  
Thermokanne  
Pot isotherme  
Jarra térmica

| art.     | lt. |
|----------|-----|
| 42405-10 | 1   |
| 42405-20 | 2   |



SS

PP

**Insulated beverage server**

Caraffa termica  
Thermokanne  
Pot isotherme  
Jarra térmica

| art.     | Ø cm. | h. cm. | lt. |
|----------|-------|--------|-----|
| 42403-01 | 16    | 20     | 1   |

8 cups. – 8 tazze.



SS

PP

**Insulated beverage server**

Caraffa termica  
Thermokanne  
Pot isotherme  
Jarra térmica

| art.     | Ø cm. | h. cm. | lt. |
|----------|-------|--------|-----|
| 42403B01 | 16    | 20     | 1   |

8 cups. – 8 tazze.



SS

**French press**

Caffettiera pressa filtro  
Kaffeebereiter  
Cafetière à piston  
Jarra para infusiones

| art.     | ml. | col. |
|----------|-----|------|
| 42407-03 | 350 | ●    |
| 42407-06 | 600 | ●    |



NEW

SS

**French press**

Caffettiera pressa filtro  
Kaffeebereiter  
Cafetière à piston  
Jarra para infusiones

| art.     | ml. |
|----------|-----|
| 42408-03 | 350 |
| 42408-06 | 600 |
| 42408-08 | 800 |



PC

**Water jug**

Caraffa  
Wasserkrug  
Crûche à eau  
Jarra agua

| art.     | Ø cm. | h. cm. | lt. |
|----------|-------|--------|-----|
| 44999-09 | 10    | 15     | 0,9 |
| 44999-16 | 12    | 20     | 1,6 |



**Water jug**

Caraffa  
Wasserkrug  
Crûche à eau  
Jarra agua

| art.     | Ø cm. | h. cm. | lt. |
|----------|-------|--------|-----|
| 44992-03 | 26    | 29     | 3   |



**Water jug**

Caraffa  
Wasserkrug  
Crûche à eau  
Jarra agua

| art.     | Ø cm. | h. cm. | lt. |
|----------|-------|--------|-----|
| 44994-00 | 14    | 29     | 2,5 |



**Water jug**

Caraffa  
Wasserkrug  
Crûche à eau  
Jarra agua

| art.     | Ø cm. | h. cm. | lt. |
|----------|-------|--------|-----|
| 44992-02 | 16,5  | 26     | 2   |



PC

**Water jug**

Caraffa  
Wasserkrug  
Crûche à eau  
Jarra agua

| art.     | dim. cm.  | lt. |
|----------|-----------|-----|
| 44871-28 | 12x13,8   | 0,5 |
| 44871-30 | 17,4x17   | 1,0 |
| 44871-32 | 18,7x19,8 | 1,5 |
| 44871-34 | 21,6x18,8 | 2,0 |

**Withstands temperatures/Termoresistenti**  
da: -30° +120°C.



PP

**Lid**

Coperchio  
Deckel  
Couvercle  
Tapa

| art.     | dim. cm. | fits/per | U. Pack |
|----------|----------|----------|---------|
| 44871-29 | 9,9x1,4  | l. 0,5   | 10      |
| 44871-31 | 11,2x1,9 | l. 1,0   | 10      |
| 44871-33 | 14x2,4   | l. 1,5   | 10      |
| 44871-35 | 15,9x2,2 | l. 2,0   | 10      |

**Withstands temperatures/Termoresistenti**  
da: -40° +100°C.



**Juice pitcher, glass**

Caraffa vetro  
Saftkanne, Glas  
Carafe à jus, verre  
Jarra zumo, vidrio

| art.     | Ø cm. | h. cm. | lt. |
|----------|-------|--------|-----|
| 44995-15 | 9,5   | 27     | 1,5 |

**Stainless steel lid. – Coperchio inox. -10°C/+110°C**



**Juice pitcher, glass**

Caraffa vetro  
Saftkanne, Glas  
Carafe à jus, verre  
Jarra zumo, vidrio

| art.     | Ø cm. | h. cm. | lt. |
|----------|-------|--------|-----|
| 44995-14 | 16    | 27     | 1,4 |

**Spout opens and closes automatically. Chromed foot with cooler, keep drinks chilled up to 4 hours. – Tappo apre e chiude automaticamente. Piede cromato con eutettico, mantiene le bevande refrigerate fino a 4 ore.**



**Juice pitcher, glass**

Caraffa vetro  
Saftkanne, Glas  
Carafe à jus, verre  
Jarra zumo, vidrio

| art.     | Ø cm. | h. cm. | lt. |
|----------|-------|--------|-----|
| 44995-10 | 9,5   | 29     | 1   |

**Spout opens and closes automatically while serving. – Tappo versatore apre e chiude automaticamente.**



PC

PP

**Juice pitcher with lid**

Caraffa con coperchio  
Saftkanne mit Deckel  
Carafe à jus avec couvercle  
Jarra zumo con tapa

| art.     | Ø cm. | h. cm. | lt. |
|----------|-------|--------|-----|
| 44993-01 | 11    | 30     | 1,6 |

**Screwed lid, aroma-tight. Coperchio avvitato, a tenuta di aroma.**



SS

**Tea strainer**

Passathé  
Teesieb  
Passoire à thé  
Colador de tè

art. Ø cm.  
41529-05 5



SS

**Tea strainer**

Passathé  
Teesieb  
Passoire à thé  
Colador de tè

art. Ø cm.  
41530-05 5



SS

**Tea strainer**

Passathé  
Teesieb  
Passoire à thé  
Colador de tè

art. Ø cm.  
41530-11 5



SS

**Tea strainer**

Passathé  
Teesieb  
Passoire à thé  
Colador de tè

art. Ø cm.  
41530-07 7,5



SS

**Tea strainer**

Passathé  
Teesieb  
Passoire à thé  
Colador de tè

art. Ø cm.  
42617-04 4,5  
42617-05 5,0  
42617-06 6,5  
42617-07 7,5



SS

**Toast rack**

Portatoast  
Toastständer  
Support pour toast  
Porta tostadas

art. dim. cm.  
41599-08 20x11x5,7



SS

**Egg cup**

Portauovo  
Eierbecher  
Coquetier  
Soporte huevos

art. Ø cm.  
41598-00 8,5



MF

**Egg cup, 4 pcs set**

Portauovo, set 4 pz  
Eierbecher, 4 Stk  
Coquetier, set 4 pcs  
Soporte huevos, set 4 pz

art. Ø cm.  
41597-04 8,5



SS

PR

**Mustard cup**

Senapiera  
Senfschale  
Moutardier  
Mostacero

art. Ø cm.  
41564-07 7



SS

PR

**Butter cup**

Coppa burro  
Butterservierer  
Coupe à beurre  
Copa mantequilla

art. Ø cm.  
41563-07 7



SS

PR

**Butter cup**

Coppa burro  
Butterservierer  
Coupe à beurre  
Copa mantequilla

art. Ø cm.  
41561-09 9



SS

**Insulated sauce boat**

Salsiera termica  
Thermo-Sauciere, doppelwandig  
Saucière isotherme  
Salsera termica

art. dim. cm. lt.  
41620-04 19x12,5x13 0,4



SS

**Gravy boat with foot**

Salsiera con piede  
Saucière mit Fuss  
Saucière sur pied  
Salsera con pie

| art.     | lt.  |
|----------|------|
| 41615-01 | 0,15 |
| 41615-03 | 0,25 |
| 41615-05 | 0,45 |



PR

**Soup bowl, lion-headed**

Ciotola testa di leone  
Suppentasse Löwenkopf  
Soupière tête de lion  
Tazón cabeza de león

| art.     | Ø cm. | lt. |
|----------|-------|-----|
| 44379-05 | 17    | 0,5 |



PC

**Salad bowl**

Insalatiera  
Salatschüssel  
Saladier  
Bol para ensalada

| art.     | Ø cm. | h. cm. | lt.  |
|----------|-------|--------|------|
| 44950-15 | 15,2  | 5,0    | 0,6  |
| 44950-20 | 20,3  | 6,5    | 1,7  |
| 44950-25 | 25,4  | 8,0    | 3,0  |
| 44950-30 | 30,5  | 10,0   | 5,5  |
| 44950-38 | 38,1  | 12,5   | 10,6 |



PC

**Salad bowl**

Insalatiera  
Salatschüssel  
Saladier  
Bol para ensalada

| art.     | dim. cm. |
|----------|----------|
| 44357-10 | 24x24x10 |
| 44357-15 | 24x24x15 |



PC

**Salad bowl**

Insalatiera  
Salatschüssel  
Saladier  
Bol para ensalada

| art.     | dim. cm. |
|----------|----------|
| 44357B10 | 24x24x10 |
| 44357B15 | 24x24x15 |



SS

**Fruit basket, oval**

Cesto frutta, ovale  
Obstschale, oval  
Panier à fruits, ovale  
Cesta fruta, oval

| art.     | dim. cm. |
|----------|----------|
| 42956-19 | 19x15    |
| 42956-24 | 24,5x18  |
| 42956-28 | 28x21    |



SS

**Fruit basket, round**

Cesto frutta, tondo  
Obstschale, rund  
Panier à fruits, rond  
Cesta fruta, redonda

| art.     | Ø cm. |
|----------|-------|
| 41629-17 | 17,0  |
| 41629-20 | 20,0  |
| 41629-25 | 25,5  |



**Wire basket, cotton linen**

Cesto in filo, fodera cotone  
Drahtkorb, Baumwollfutter  
Panier métallique, doublure en coton  
Cesta de alambre, forro de algodón

| art.     | dim. cm.   |
|----------|------------|
| 42878-17 | 17x12,5x8  |
| 42878-25 | 25x15,5x12 |



**Wire basket, cotton linen**

Cesto in filo, fodera cotone  
Drahtkorb, Baumwollfutter  
Panier métallique, doublure en coton  
Cesta de alambre, forro de algodón

| art.     | dim. cm.  |
|----------|-----------|
| 42877-17 | 17x12,5x8 |
| 42877-25 | 25x17x12  |



**Kraft paper bag, washable**

Cesto pane di carta kraft lavabile  
Kraftpapierbrottasche, waschbar  
Panier en papier kraft lavable  
Cesta pan de papel kraft lavable

| art.     | Ø cm. | h. cm. |
|----------|-------|--------|
| 42879M12 | 12    | 12     |
| 42879M15 | 15    | 10     |
| 42879M22 | 22    | 13     |
| 42879M25 | 25    | 18     |



**Kraft paper bag, washable**

Cesto pane di carta kraft lavabile  
Kraftpapierbrottasche, waschbar  
Panier en papier kraft lavable  
Cesta pan de papel kraft lavable

| art.     | Ø cm. | h. cm. |
|----------|-------|--------|
| 42879K12 | 12    | 12     |
| 42879K15 | 15    | 10     |
| 42879K22 | 22    | 13     |
| 42879K25 | 25    | 18     |





**Bread basket**

Cesto pane  
Brotkorb  
Corbeille à pain  
Cesta pan

| art.     | Ø cm. | h. cm. |
|----------|-------|--------|
| 42948-18 | 10    | 7      |
| 42948-20 | 20    | 7      |
| 42948-25 | 25    | 7      |



**Bread basket**

Cesto pane  
Brotkorb  
Corbeille à pain  
Cesta pan

| art.     | dim. cm.  |
|----------|-----------|
| 42948-23 | 23x15x6,5 |



**Bread basket**

Cesto pane  
Brotkorb  
Corbeille à pain  
Cesta pan

| art.     | Ø cm. | h. cm. |
|----------|-------|--------|
| 42935-19 | 19    | 9      |
| 42935-26 | 26    | 9      |



**Bread basket**

Cesto pane  
Brotkorb  
Corbeille à pain  
Cesta pan

| art.     | Ø cm. | h. cm. |
|----------|-------|--------|
| 42944-23 | 23    | 7      |



**Bread basket**

Cesto pane  
Brotkorb  
Corbeille à pain  
Cesta pan

| art.     | dim. cm. |
|----------|----------|
| 42945-27 | 27x20x10 |



**Bread basket**

Cesto pane  
Brotkorb  
Corbeille à pain  
Cesta pan

| art.     | dim. cm.  |
|----------|-----------|
| 42945-18 | 18x13x6,5 |
| 42945-23 | 23x15x6,5 |



**Bread basket**

Cesto pane  
Brotkorb  
Corbeille à pain  
Cesta pan

| art.     | Ø cm. | h. cm. | col. |
|----------|-------|--------|------|
| 42974C13 | 13    | 10     | ●    |
| 42974B13 | 13    | 10     | ●    |
| 42974M13 | 13    | 10     | ●    |
| 42974N13 | 13    | 10     | ●    |



**Canvas bag, round**

Cesto cotone, rotondo  
Brottasche, rund, Baumwolle  
Panier à pain rond, coton  
Cesta pan redonda, algodón

| art.     | Ø cm. | h. cm. |
|----------|-------|--------|
| 42875-17 | 17    | 8      |
| 42875-20 | 20    | 9      |

**Cotton, machine-washable up to 30° C.**  
Cotone, lavabile a macchina fino a 30° C.



**Canvas bag, round**

Cesto cotone, rotondo  
Brottasche, rund, Baumwolle  
Panier à pain rond, coton  
Cesta pan redonda, algodón

| art.     | Ø cm. | h. cm. |
|----------|-------|--------|
| 42875B17 | 17    | 8      |
| 42875B20 | 20    | 9      |

**Cotton, machine-washable up to 30° C.**  
Cotone, lavabile a macchina fino a 30° C.



**Canvas bag, oval**

Cesto cotone, ovale  
Brottasche, oval, Baumwolle  
Panier à pain ovale, coton  
Cesta pan , algodón

| art.     | dim. cm. |
|----------|----------|
| 42876-20 | 20x15x7  |
| 42876-25 | 25x18x9  |

**Cotton, machine-washable up to 30° C.**  
Cotone, lavabile a macchina fino a 30° C.



**Canvas bag, oval**

Cesto cotone, ovale  
Brottasche, oval, Baumwolle  
Panier à pain ovale, coton  
Cesta pan , algodón

| art.     | dim. cm. |
|----------|----------|
| 42876B20 | 20x15x7  |
| 42876B25 | 25x18x9  |

**Cotton, machine-washable up to 30° C.**  
Cotone, lavabile a macchina fino a 30° C.



**Canvas bag, round**

Cesto cotone, rotondo  
Brottasche, rund, Baumwolle  
Panier à pain, coton  
Cesta pan, algodón

| art.     | Ø cm. | h. cm. | col. |
|----------|-------|--------|------|
| 42873-01 | 20    | 23,5   | ●    |

**Ceramic stone pillow included. Easy to heat up in microwave for 90 sec. at 500 Watt.**  
Cuscino con sfere ceramica incluso. Scaldare in microonde per 90 secondi a 500 Watt.



W

**Bowl, oval**  
Ciotola ovale  
Schüssel, oval  
Bassine ovale  
Bol oval

| art.     | dim. cm. |
|----------|----------|
| 42931-19 | 19,5x17  |



SS

**Truffle-slicer**  
Tagliatartufi  
Trüffelschneider  
Coupe-truffes  
Corta trufa

| art.     | dim. cm. | des.     |
|----------|----------|----------|
| 48237-00 | 21x8,5   | plain    |
| 48237-01 | 21x8,5   | serrated |



SS

**Truffle-slicer**  
Tagliatartufi  
Trüffelschneider  
Coupe-truffes  
Corta trufa

| art.     | dim. cm. | des.     |
|----------|----------|----------|
| 48236-00 | 21x8,5   | plain    |
| 48236-01 | 21x8,5   | serrated |

Rosewood handle. – Manico in palissandro.



PC

**Truffle jar**  
Contentore tartufi  
Trüffel-Verpackung  
Réceptif à truffes  
Envasado para trufa

| art.     | Ø cm. | h. cm. |
|----------|-------|--------|
| 48237-99 | 6     | 4,5    |

For transport and storage, prevents weight loss.  
Per trasporto e conservazione, previene il calo di peso.



**Truffle server**  
Servitartufi  
Trüffel-Service  
Service à truffes  
Servidor de trufas

| art.     | dim. cm. |
|----------|----------|
| 48237-35 | 30x20x9  |

Chesnut wood. – Castagno.



NEW

**Tray with dome cover**  
Vassoio con campana  
Tablett mit Haube  
Plat avec cloche  
Bandeja con campana

| art.     | Ø cm. | h. cm. |
|----------|-------|--------|
| 41416-18 | 18,5  | 24,5   |

Beech wood tray with glass cover Ø 16 H 22,5 cm. – Vassoio in legno di faggio con coperchio in vetro Ø 16 H 22,5 cm.



SS

**Salt/pepper shaker set**  
Set spargisale/pepe  
Salz- und Pfefferstreuer-Set  
Set salière et poivrier  
Juego salero y pimentero

| art.     | Ø cm. | h. cm. |
|----------|-------|--------|
| 42924-02 | 5     | 6,5    |



SS

**Salt/pepper shaker, set 12 pcs**  
Spargisale/pepe, set 12 pz  
Salz-/Pfefferstreuer, 12 Stk  
Salière/poivrier, set 12 pcs  
Salero/pimentero, juego 12 pz

| art.     | Ø cm. | h. cm. |
|----------|-------|--------|
| 42926-12 | 3     | 9      |



SS

**Condiment set, 2 pcs**  
Set 2 pz sale e pepe  
Menage, 2-teilig  
Ménagère, 2 pièces  
Servicio de mesa, 2 piezas

| art.     | dim. cm. |
|----------|----------|
| 42927-02 | 3x3x5    |



**Salt/pepper shaker, chrome top**  
Spargisale/pepe cromato  
Salz-/Pfefferstreuer, verchromt  
Salière/poivrier, chromé  
Salero/pimentero, cromado

| art.     | ml. |
|----------|-----|
| 42928-00 | 45  |



SS

**Condiment set, 2 pcs**  
Sale e pepe, 2 pezzi  
Menage, 2-teilig  
Ménagère, 2 pièces  
Servicio de mesa, 2 piezas

| art.     | dim. cm.    |
|----------|-------------|
| 42929-01 | 11,5x5,5x17 |

Wood base, satin polished handle.  
Base legno, manico satinato.



SS

**Condiment set, 2 pcs**

Servizio oliera, 2 pezzi  
Menage, 2-teilig  
Ménagère, 2 pièces  
Servicio de mesa, 2 piezas

art. dim. cm.

42929-02 16x7,5x24,5

**Wood base, satin polished handle.**

Base legno, manico satinato.



SS

**Condiment set, 4 pcs**

Servizio oliera, 4 pezzi  
Menage, 4-teilig  
Ménagère, 4 pièces  
Servicio de mesa, 4 piezas

art. dim. cm.

42929-03 15,5x12x24,5

**Wood base, satin polished handle.**

Base legno, manico satinato.



SS

**Oil and winegar stand**

Porta olio/acetato  
Essig u. Öl-Stand  
Porte huile et vinaigre  
Soporte para aceite y vinagre

art. dim. cm.

66362-02 12,5x6x27



SS

**Oil/vinegar sprayer, 2 pcs**

Nebulizzatore olio/acetato, 2 pz  
Öl-/Essigsprühflasche, 2 Stück  
Nébuliseur huile vinaigre, 2 pièces  
Nebulizador aceite/vinagre, 2 pz

art. Ø cm. h. cm. ml.

41635-02 4 18 110



SS

**Oil and winegar stand**

Porta olio/acetato  
Essig u. Öl-Stand  
Porte huile et vinaigre  
Soporte para aceite y vinagre

art. dim. cm.

41636-25 13x7x30



SS

**Condiment set, 4 pcs**

Servizio oliera, 4 pezzi  
Menage, 4-teilig  
Ménagère, 4 pièces  
Servicio de mesa, 4 piezas

art. dim. cm.

41638-04 17,5x10,5x23



SS

**Condiment set, 2 pcs**

Servizio oliera, 2 pezzi  
Menage, 2-teilig  
Ménagère, 2 pièces  
Servicio de mesa, 2 piezas

art. dim. cm.

41638-02 14,5x8,5x23



SS

**Condiment set, 2 pcs**

Sale e pepe, 2 pezzi  
Menage, 2-teilig  
Ménagère, 2 pièces  
Servicio de mesa, 2 piezas

art. dim. cm.

41638-12 10,5x6,5x16



SS

**Condiment set, 3 pcs**

Set sale, pepe, stecchi  
Menage, 3-teilig  
Ménagère, 3 pièces  
Servicio de mesa, 3 piezas

| art.     | Ø cm. | h. cm. |
|----------|-------|--------|
| 41638-13 | 10,5  | 16     |



SS

**Cheese jar**

Formaggiera  
Käsedose  
Fromagère  
Quesera

| art.     | Ø cm. | h. cm. |
|----------|-------|--------|
| 41638-01 | 10,5  | 7      |



SS

**Cheese shaker**

Spargiformaggio  
Käsestreuer  
Poudreuse à fromage  
Colteler de queso

| art.     | ml. |
|----------|-----|
| 42921-00 | 360 |



PP

**Cutlery/breadstick basket**

Portaposate/grissini  
Besteck-/Salzstangenkorb  
Panier à couverts/gressins  
Cesta cubiertos/palitos de pan

| art.     | Ø cm. | h. cm. |
|----------|-------|--------|
| 42584-01 | 12    | 15     |



PP

**Cutlery dispenser**

Portaposate  
Besteck-Ablage  
Panier à couverts  
Cesta portacubiertos

| art.     | dim. cm.  |
|----------|-----------|
| 42584-02 | 27x10x4,5 |



PP

**Cutlery dispenser**

Portaposate  
Besteck-Ablage  
Panier à couverts  
Cesta portacubiertos

| art.     | dim. cm.   |
|----------|------------|
| 42584-04 | 53x32,5x10 |



PP

**Cutlery dispenser**

Portaposate  
Besteck-Ablage  
Panier à couverts  
Cesta portacubiertos

| art.     | dim. cm.  |
|----------|-----------|
| 42584-05 | 53x32,5x9 |



PP

**Cutlery dispenser**

Portaposate  
Besteck-Ablage  
Panier à couverts  
Cesta portacubiertos

| art.     | dim. cm. | col. |
|----------|----------|------|
| 42584-06 | 26x18x15 | ●    |
| 42584-07 | 26x18x15 | ●    |



W

**Table caddy**

Portacondimenti  
Tisch-Caddy  
Caddy de table  
Caddy de mesa

| art.     | Ø cm. | h. cm. |
|----------|-------|--------|
| 41639-17 | 17,5  | 8,5    |



W

**Cutlery dispenser**

Portaposate  
Besteck-Ablage  
Panier à couverts  
Cesta portacubiertos

| art.     | Ø cm. | h. cm. |
|----------|-------|--------|
| 41639-11 | 11,5  | 14     |



W

**Table caddy 4 compartments**

Portacondimenti 4 comparti  
Tisch-Caddy 4-Fächer  
Caddy de table 4 compartiments  
Caddy de mesa 4 compartimentos

| art.     | dim. cm. | col. |
|----------|----------|------|
| 41639-30 | 17x17x10 | ○    |
| 41639-31 | 17x17x10 | ●    |
| 41639-32 | 17x17x10 | ●    |

Compartments/Scomparti 7x7 cm.





W

**Table caddy 6 compartments**

Portacondimenti 6 compart

Tisch-Caddy 6-Fächer

Caddy de table 6 compartiments

Caddy de mesa 6 compartimentos

art. dim. cm. col.

41639-40 27x17x10 ○

41639-41 27x17x10 ●

41639-42 27x17x10 ●

**Compartments/Scomparti 7,5x7,5 cm.**



SS

**Table-cloth clips, 4 pcs set**

Fermatovaglia, set 4 pz

Tischtuch Klammer, 4 Stk

Pinces à nappe, 4 pièces

Pinzas para mantel, 4 piezas

art.

42953-04

**For table/Per tavoli h 3 cm.**



SS

**Napkin holder**

Legatovagliolo

Serviettenring

Porteserviette

Servilletero

art.

42955-00



SS

**Dome cover**

Cloche

Speiseglocke

Cloche

Cubreplatos

art. Ø cm. h. cm.

41560-28 29 18



SS

ABS

**Pocket crumbler**

Raccoglibriciole tascabile

Krümelsammler taschenformat

Ramasse miettes de poche

Recogemigas de bolsillo

art. dim. cm.

42593-00 14x2,7



SS

**Table crumbler**

Raccoglibriciole a tubo

Krümelsammler

Ramasse miettes

Pala recogemigas

art. dim. cm.

41679-23 23,5



**Raclette maker, 4 pans**

Macchina per raclette, 4 padelle

Raclette Tischgerät, 4 Pfannen

Appareil à raclette, 4 poêlons

Máquina raclette

art. dim. cm. W

41318-00 51x10x12 600

**Non-stick upper plate for all cooking (vegetables, meats, etc.). – Piastra superiore antiaderente per tutte le cotture (verdure, carne, ecc.).**



**Raclette maker**

Macchina per raclette  
Raclette Tischgerät  
Appareil à raclette  
Máquina raclette

| art.     | dim. cm.     | W   |
|----------|--------------|-----|
| 42420-06 | 44,5x21,5x30 | 850 |

**Foldable model with transport hook. 2 heating ramps, adjustable height. Suitable for cheese size 1/6 to 1/3 of a wheel. In stainless steel and painted steel.** – Modello pieghevole con gancio di trasporto. 2 rampe di riscaldamento, altezza regolabile. Adatto per formaggi da 1/6 a 1/3 di una forma. In acciaio inossidabile e acciaio verniciato.



**Raclette maker**

Macchina per raclette  
Raclette Tischgerät  
Appareil à raclette  
Máquina raclette

| art.     | dim. cm.   | W   |
|----------|------------|-----|
| 42420-08 | 46x26,5x40 | 850 |

**Tiltable and easily removable cheese holder. Heating block adjustable height. Ideal for 6-8 people, 1/2 shape. Cheese holder in stainless steel and epoxy painted steel structure.** – Porta formaggio inclinabile e facilmente rimovibile. Blocco riscaldante regolabile in altezza. Ideale per 6-8 persone, 1/2 forma. Porta formaggio in acciaio inossidabile e struttura in acciaio verniciato epossidico.



**Fondue set, copper**

Set fonduta, rame  
Fondue-Service, Kupfer  
Service à fondue, cuivre  
Servicio para fondues, cobre

| art.     | Ø cm. | h. cm. |
|----------|-------|--------|
| 15430-11 | 16    | 26     |



**Cheese fondue set**

Set fonduta formaggio  
Käsefondue-Service  
Service à fondue fromage  
Servicio para fondues queso

| art.     | Ø cm. | h. cm. |
|----------|-------|--------|
| 41311-00 | 20    | 18     |



**Bourguignonne fondue set**

Set fonduta bourguignonne  
Bourguignonefondue-Service  
Service à fondue bourguignonne  
Servicio para fondues bourguignonne

| art.     | Ø cm. | h. cm. |
|----------|-------|--------|
| 41312-00 | 20    | 18     |



**Dipping forks, 6 pcs**

Set forchette, 6 pz  
Fonduegabeln, 6 Stk  
Curettes à fondue, 6 pièces  
Tenedores para fondue, 6 pz

| art.     | l. cm. |
|----------|--------|
| 15428-06 | 24     |



**Stand with grill stone**

Supporto con pietra ollare  
Träger mit Kochstein  
Pierre à cuire avec support  
Soporte con piedra

| art.     | dim. cm. |
|----------|----------|
| 41315-02 | 17x20x12 |



**Stand with grill stone**

Supporto con pietra ollare  
Träger mit Kochstein  
Pierre à cuire avec support  
Soporte con piedra

| art.     | dim. cm. |
|----------|----------|
| 41315-04 | 44x20x12 |



SS

**Table barbecue, 1 closed side**

Barbecue da tavola, da esterno  
Tischgrill, 1 geschlossene Seite  
Barbecue de table 1 foyer fermé  
Barbacoa de mesa, 1 lado cerrado

art. dim. cm. Kg.

41313-00 33x22x20 7,3

**Also for outdoor use. Solid beech board. Can be put in the dishwasher once disassembled.**

Anche per uso all'esterno. Tagliere in faggio massiccio. Può essere lavato in lavastoviglie una volta smontato.



SS

**Table barbecue, 2 open sides**

Barbecue da tavola, da interno  
Tischgrill, 2 offene Seiten  
Barbecue de table 2 foyers ouverts  
Barbacoa de mesa, 2 lados abiertos

art. dim. cm. Kg.

41314-00 33x22x20 7,3

**2 open sides for indoor use. Solid beech board. Can be put in the dishwasher once disassembled.**

**Supplied with 1 steel pan Ø cm 18 and 1 spatula**  
2 lati aperti per uso interno. Tagliere in faggio massiccio. Può essere lavato in lavastoviglie una volta smontato. Fornito con 1 padella di ferro Ø cm 18 e 1 spatola.



SS

**Plate warmer**

Rechaud  
Speisenwärmer  
Chaufe-plats  
Calentador de platos

art. Ø cm. h. cm.

41317-20 20 11

**Burning time 2 hours with an average flame.**  
Tempo di combustione 2 ore a fiamma media.



SS

**Plate warmer**

Rechaud  
Speisenwärmer  
Chaufe-plats  
Calentador de platos

art. dim. cm.

41569-33 33x18x6,5

**Aluminum plate. – Piastra in alluminio.**



**Mussel pot, enamel cast-iron**

Cocotte per molluschi, ferro smaltato  
Muscheltopf, emaillierts Stahlblech  
Casserole coquillage, émaillée  
Cacerola para mejillones, esmaltada

art. Ø cm. h. cm. lt.

42414-05 13,5 9,0 0,8

42414-10 18,0 12,0 2,0

42414-15 20,0 13,0 3,0

42414-20 24,0 13,5 4,0



**Trivet, cork**

Sottopentola, sughero  
Korkuntersetzer  
Sous-plat, liège  
Posavasos de corcho

art. Ø cm.

42413-24 24



SS

**Stand with 4 skewers**

Supporto con 4 spiedini  
Träger mit 4 Fleischspiesen  
Support avec 4 brochettes  
Soporte con 4 brochetas

art. Ø cm. h. cm.

42417-22 22 46



SAN

**Swing table top waste bin**

Portarifiuti da tavola  
Tischeimer  
Poubelle dé table  
Papelera sobremesa, plástico

| art.     | Ø cm. | h. cm. |
|----------|-------|--------|
| 42959-13 | 12    | 18     |



SS

**Swing table top waste bin**

Portarifiuti da tavola  
Tischeimer  
Poubelle dé table  
Papelera sobremesa

| art.     | Ø cm. | h. cm. |
|----------|-------|--------|
| 42959-12 | 12    | 17     |



**Nut-cracker**

Schiaccianoci  
Nussknacker  
Casse-noix  
Cascanueces

| art.     |
|----------|
| 48211-00 |



SS

**Nut-cracker**

Schiaccianoci  
Nussknacker  
Casse-noix  
Cascanueces

| art.     | l. cm. |
|----------|--------|
| 48210-00 | 15,3   |



SS

**Lobster cracker**

Pinza aragosta  
Hummerzange  
Pince à homard  
Pinza bogavante

| art.     | l. cm. |
|----------|--------|
| 48239-00 | 20     |



**Lobster cracker, aluminum**

Pinza aragosta, alluminio  
Hummerzange, Aluminum  
Pince à homard, alu  
Pinza bogavante, alluminio

| art.     | dim. cm. |
|----------|----------|
| 48240-00 | 14,5x6,5 |



SS

**Sea urchin cutter**

Taglia ricci di mare  
Seeigel-Messer  
Coupe oursin  
Cortador de erizo de mar

| art.     | dim. cm. |
|----------|----------|
| 48286-68 | 6x22     |



SS

**Lobster pick**

Stiletto aragosta  
Hummergabel  
Curette à homard  
Tenedor bogavante

| art.     | l. cm. |
|----------|--------|
| 48238-00 | 20     |



SS

**Lobster forks**

Forchettine per aragosta  
Hummergäbelchen  
Curettes à homard  
Tenedores bogavante

| art.     | dim. cm. | U. Pack |
|----------|----------|---------|
| 41594-18 | 18       | 5       |



SS

**Picks, set 12 pcs**

Spilloncini, set 12 pz  
Stoher, 12 Stk.  
Pic-bigorneaux, set 12 pcs  
Pico-caracoles, juego 12 pz

| art.     |
|----------|
| 41594-12 |



SS

**Escargot picks, chromed, set 12 pcs**

Forchettine lumache, cromate, set 12 pz  
Schnecken-gabel, verchromed, 12 Stk.  
Pic-escargots, chromés, set 12 pcs  
Pico-caracoles, cromados, juego 12 pz

| art.     | l. cm. |
|----------|--------|
| 41686-12 | 8      |



SS

**Escargot dish**

Piatto lumache  
Schneckenplatte  
Plat à escargots  
Plato caracoles

| art.     | Ø cm.     | comp. |
|----------|-----------|-------|
| 41687-06 | 15,5/17,5 | 6     |
| 41687-12 | 19/22,5   | 12    |





SS

**Caviar cooler**

Coppa caviale  
Kaviarkühler  
Rafraîchisseur à caviar  
Copa caviar

| art.     | Ø cm. | h. cm. |
|----------|-------|--------|
| 41562-18 | 18    | 5      |



**Caviar flatware, mother of pearl**

Posate caviale, madreperla  
Kaviar-Bestecke, Perlmuttern  
Couverts à caviar, nacre  
Cubeteria caviar, nácar

| art.     | dim. cm. | des.  |
|----------|----------|-------|
| 41518-00 | 10       | spoon |
| 41518-01 | 10       | knife |
| 41518-02 | 10       | fork  |



SS

**Oyster tray**

Vassoio frutti di mare  
Austernplatte  
Plat à huîtres  
Fuente de mariscos

| art.     | Ø cm. | h. cm. |
|----------|-------|--------|
| 41592-36 | 36    | 4,0    |
| 41592-45 | 45    | 5,5    |



SS

**Oyster tray**

Vassoio frutti di mare  
Austernplatte  
Plat à huîtres  
Fuente de mariscos

| art.     | Ø cm. |
|----------|-------|
| 41591-90 | 45-36 |



**Seafood display rack, chromed**

Supporto acciaio cromato  
Unterteil für Austernplatte, verchromt  
Support en fil chromé  
Soporte cromado para fuente mariscos

| art.     | Ø cm. | h. cm. |
|----------|-------|--------|
| 41593-20 | 19-25 | 20     |



**Oyster tray, aluminum**

Vassoio frutti di mare, alluminio  
Austernplatte, Aluminum  
Plat à huîtres, alu  
Fuente de mariscos, aluminio

| art.     | Ø cm. | h. cm. |
|----------|-------|--------|
| 41591-32 | 32    | 6      |
| 41591-36 | 36    | 6      |
| 41591-40 | 40    | 6      |
| 41591-45 | 45    | 6      |



SS

**Oyster/fruit stand**

Alzata Royale  
Austern-/Obstständer  
Etagère Royale  
Expositor de mariscos/frutas

| art.     | Ø cm.    | h. cm. |
|----------|----------|--------|
| 41820-03 | 24-33-42 | 50     |





SS

**Table bag holder**  
Gancio appendi borsa  
Handtaschentischhänger  
Crochet de table  
Colgador de bolso  
art.  
41559-04



**Wine bucket table clip, chrome**  
Supporto secchio vino tavola, cromato  
Weinkühler-Tischbefestigung, verchromt  
Porte-seau à vin, chromé  
Soporte de mesa cubo vino, cromado  
art.  
41558-00

Per/For: 41501-20, 41502-20.



SS

**Wine bucket**  
Secchiello vino  
Weinkühler  
Seau à vin  
Cubo vino  
art.      Ø cm.    h. cm.  
41502-20    20      20



**Wine bucket, aluminum**  
Secchiello vino, alluminio  
Weinkühler, Aluminium  
Seau à vin, alu  
Cubo vino, aluminio  
art.      Ø cm.    h. cm.  
41501-20    20      21



SS

**Wine cooler**  
Secchiello vino  
Weinkühler  
Seau à vin  
Cubo vino  
art.      Ø cm.    h. cm.    bot.  
46120-18    17,0    16      1/2  
46120-22    21,5    21      1  
46120-24    24,0    22      2



SS

**White wine cooler**  
Secchio vino bianco  
Weissweinkühler  
Seau à vin blanc  
Cubo vino blanco  
art.      Ø cm.    h. cm.  
46118-20    20      25



SS

**Wine cooler stand**  
Colonna portasecchiello  
Ständer für Weinkühler  
Support seau à champagne  
Soporte para cubo  
art.      Ø cm.    h. cm.  
41505-20    20      70,5



SS

**Wine cooler stand**  
Colonna portasecchiello  
Ständer für Weinkühler  
Support seau à champagne  
Soporte para cubo  
art.      Ø cm.    h. cm.  
41505-17    17,5    64  
41505-19    19,5    64



SS

**Bottle cooler**  
Glacette termica  
Flaschenkühler  
Rafraichisseur à bouteille  
Enfriador isotémico  
art.      Ø cm.    h. cm.  
41508C12    12/10    20



**Bottle cooler, concrete**  
Glacette, cemento  
Flaschenkühler, Beton  
Rafraîchisseur à bouteille, béton  
Enfriador, cemento

art. Ø cm. h. cm.  
41504-19 12/10 19



**Bottle cooler**  
Glacette termica  
Flaschenkühler  
Rafraîchisseur à bouteille  
Enfriador isotérmico

art. Ø cm. h. cm.  
41504-09 9,5 22,5



**Bottle cooler**  
Glacette termica  
Flaschenkühler  
Rafraîchisseur à bouteille  
Enfriador isotérmico

art. Ø cm. h. cm.  
41504-10 10 21



**Bottle cooler**  
Glacette termica  
Flaschenkühler  
Rafraîchisseur à bouteille  
Enfriador isotérmico

art. Ø cm. h. cm.  
41508-10 10 30



**Bottle cooler**  
Glacette termica  
Flaschenkühler  
Rafraîchisseur à bouteille  
Enfriador isotérmico

art. Ø cm. h. cm.  
41504-12 12,5/10 22



**Bottle cooler**  
Glacette termica  
Flaschenkühler  
Rafraîchisseur à bouteille  
Enfriador isotérmico

art. Ø cm. h. cm.  
41504-11 10 22



**Bottle cooler**  
Glacette termica  
Flaschenkühler  
Rafraîchisseur à bouteille  
Enfriador isotérmico

art. Ø cm. h. cm.  
41507-01 11,5/9,5 23



**Wine holder**  
Versavino a molla  
Weingestell  
Porte-Bouteille  
Soporte para botella

art. Ø cm.  
41510-08 8



**Wine holder**  
Versavino reversibile  
Weingestell  
Porte-Bouteille  
Soporte para botella

art. l. cm.  
46123-00 17



**Wine collar, chromed**

Collare salvagoccia, cromato  
Tropfenfänger, verchromt  
Collier anti-gouttes, chromé  
Anillo anti-goteo, cromado

art.

41511-00



SS

**Wine taster with ring and cord**

Tastevin con anello e cordino  
Weinprobenschale mit Ring und Schnur  
Tastevin avec anneau et cordon  
Catador del vino con anillo y cordón

art. Ø cm.

41499-08 8,5



**Cognac warmer, palladium**

Scaldacognac, palladio  
Cognacwärmer, Palladium  
Réchaud à cognac, palladium  
Calentador brandy, paladio

art. h. cm.

41678-14 14,5



**Champagne saber**

Sciabola per Sommelier  
Champagnersäbel  
Sabra à champagne  
Sable para Champán

art. l. cm.

41496-40 40



**Champagne tongs, chromed**

Pinza champagne, cromata  
Champagner-Zange, verchromed  
Pince à champagne, chromée  
Pinza Champaña, cromada

art.

41511-30



SS

**Pourer**

Versatore  
Ausgießer  
Verseur  
Vertedor

art.

41511-20



**Flower vase, nickel plated**

Vaso fiori, nichelato  
Blumenvase, vernickelt  
Vase à fleurs, nickelé  
Florero, zinc-niquel

art. Ø cm. h. cm.

42942-16 4 16,5



SS

**Flower vase**

Vaso fiori  
Blumenvase  
Vase à fleurs  
Florero

art. h. cm.

41628-15 15



AG

**Candlestick**

Candelieri  
Kerzenleuchter  
Chandelier  
Candelabro una vela

art. Ø cm. h. cm.

32931-02 10 20,5



AG

**Candelabra 3 lights**

Candelabro 3 luci  
Kerzenleuchter, 3-flammig  
Chandelier, 3 branches  
Candelabro, 3 brazos

art. Ø cm. h. cm.

32931-03 10 22,5



AG

**Candelabra 5 lights**

Candelabro 5 luci  
Kerzenleuchter, 5-flammig  
Chandelier, 5 branches  
Candelabro, 5 brazos

art. Ø cm. h. cm.

32931-05 10 24





AG

**Candlestick**

Candeliere  
Kerzenleuchter  
Chandelier

Candelabro una vela

| art.     | Ø cm. | h. cm. |
|----------|-------|--------|
| 32935-10 | 10    | 10     |
| 32935-22 | 10    | 22     |



**Candelabra 5 lights, nickel-plated**

Candelabro 5 luci, nichelato  
Kerzenleuchter, 5-flammig, vernickelt  
Chandelier, 5 branches, nickelé  
Candelabro, 5 brazos, niquelado

| art.     | Ø cm. | h. cm. |
|----------|-------|--------|
| 42443-06 | 17    | 56     |
| 42443-08 | 24    | 78     |



AG

**Candelabra 3 lights**

Candelabro 3 luci  
Kerzenleuchter, 3-flammig  
Chandelier, 3 branches  
Candelabro, 3 brazos

| art.     | Ø cm. | h. cm. |
|----------|-------|--------|
| 32935-03 | 11    | 25     |



AG

**Candelabra 5 lights**

Candelabro 5 luci  
Kerzenleuchter, 5-flammig  
Chandelier, 5 branches  
Candelabro, 5 brazos

| art.     | Ø cm. | h. cm. |
|----------|-------|--------|
| 32935-05 | 11    | 25     |



AG

**Candelabra 3 lights**

Candelabro 3 luci  
Kerzenleuchter, 3-flammig  
Chandelier, 3 branches  
Candelabro, 3 brazos

| art.     | Ø cm. | h. cm. |
|----------|-------|--------|
| 32936-03 | 13    | 39     |



AG

**Candelabra 5 lights**

Candelabro 5 luci  
Kerzenleuchter, 5-flammig  
Chandelier, 5 branches  
Candelabro, 5 brazos

| art.     | Ø cm. | h. cm. |
|----------|-------|--------|
| 32936-05 | 13    | 39     |



SS

**Candleholder satin finish, set 2 pcs**

Portacandela satinato, set 2 pz  
Windlicht, mattiert, 2er Set  
Bougeoir satin mat, set 2 pcs  
Portavela satinado, set 2 pz

| art.     | Ø cm. | h. cm. |
|----------|-------|--------|
| 42939-15 | 5     | 15     |



**Candleholder, chromed**

Portacandela, cromato  
Windlicht, verchromt  
Bougeoir, chromé  
Portavela, cromado

| art.     | Ø cm. | h. cm. |
|----------|-------|--------|
| 42941-22 | 11    | 22     |





**Set 4 tea light candles**

Set 4 candele tea light  
Kunstteelichter, 4er Set  
Set 4 bougies chauffeplat  
Set 4 velas de tè

art. Ø cm. h. cm.

42446-04 3,65 3,53

**Resin. Timer function 5 hours ON/19 OFF. Powered by one CR2450 alkaline battery (not incl.). Working time >50 hours. Flameless moving wick.** – Resina. Funzione timer 5 ore ON/19 OFF. 1 batteria alcalina CR2450 (non incl.). Durata > 50 ore. Stoppino mobile senza fiamma.



**Set 3 candele**

Set 3 candles  
Kunstkerzen, 3er Set  
Set 3 bougies  
Set 3 velas

art. Ø cm. h. cm.

42445-03 9 12,5  
9 18,0  
9 23,0

**Resin. Timer function 5 hours ON/19 OFF. Powered by 2D alkaline batteries (not incl.). Working time >800 hours. Flameless moving wick.** – Resina. Funzione timer 5 ore ON/19 OFF. 2 batterie alcaline D (non include). Durata > 800 ore. Stoppino mobile senza fiamma.



**Sign holders, chromed**

Clip flessibili, cromate  
Schildhalter, verchromt  
Porte-étiquettes, chromés  
Porta etichetas con clip, cromate

art. l. cm. pcs/pz

41394-02 12 2



**Menu stand**

Porta menù  
Speisekartenhalter  
Porte-menu  
Portamenús

art. dim. cm.

42951-08 8x7x2



**Table number stand, 4 pcs set**

Supporto numero tavola, set 4 pz  
Tischnummerständer, Satz 4 Stk  
Support numéro de table, set 4 pcs  
Soporte número de mesa, set 4 pz

art. Ø cm. h. cm.

42954-04 4 10



**Table number stand**

Supporto numero tavola  
Tischnummerständer  
Support numéro de table  
Soporte número de mesa

art. Ø cm. h. cm.

42954-18 7,5 18,5  
42954-29 7,5 29,0  
42954-46 7,5 46,0



**Card holder**

Supporto targhetta  
Kartenhalter  
Porte-cartes  
Portatarjetas

art. dim. cm.

42952-05 6x5x3



**Table sign, 2 pcs set**

Targhetta tavola, set 2 pz  
Tischaufsteller, Satz 2 Stk  
Plaque de table, set 2 pcs  
Placa de mesa, set 2 pz

art. dim. cm.

42951-57 5,5x5x3,5



**Table sign, 2 pcs set**

Targhetta tavola, set 2 pz  
Tischaufsteller, Satz 2 Stk  
Plaque de table, set 2 pcs  
Placa de mesa, set 2 pz

art. dim. cm.

42951-59 5,5x5x3,5



SS

**Reception bell**  
Campanella reception  
Receptionsschell  
Sonette de réception  
Timbre recepción

| art.     | Ø cm. | h. cm. |
|----------|-------|--------|
| 41390-00 | 8,5   | 6      |

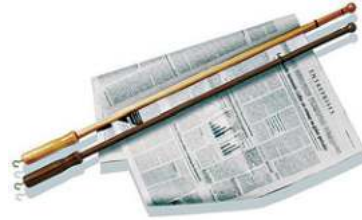

W

**Newspaper stick**  
Portagiornale  
Zeitungshalter  
Canne à journaux  
Varilla portaperiodico

| art.     | l. cm. | col. |
|----------|--------|------|
| 48287-18 | 75     | ●    |
| 48287-19 | 75     | ●    |



**Chalkmarker**  
Penna a gesso liquido  
Kreidestifte  
Stylo à craie liquide  
Rotulador de tiza líquida

| art.     | Ø mm. | col. |
|----------|-------|------|
| 47832-00 | 5     | ○    |
| 47832-01 | 5     | ●    |
| 47832-02 | 5     | ●    |
| 47832-03 | 5     | ●    |
| 47832-04 | 5     | ●    |
| 47832-05 | 5     | ●    |

**Clean with water. Writes on all non porous surfaces. – Pulire con acqua. Scrive su tutte le superfici non porose.**



**Chalkmarker**  
Penna a gesso liquido  
Kreidestifte  
Stylo à craie liquide  
Rotulador de tiza líquida

| art.     | Ø mm. | col. |
|----------|-------|------|
| 47832-10 | 15    | ○    |
| 47832-11 | 15    | ●    |
| 47832-12 | 15    | ●    |
| 47832-13 | 15    | ●    |
| 47832-14 | 15    | ●    |
| 47832-15 | 15    | ●    |



NEW

**Sandwich board**  
Lavagna cavalletto bifacciale  
Gehwegtafel  
Tableau chevalet 2 faces  
Pizarra en ángulo

| art.     | dim. cm. | h. cm. |
|----------|----------|--------|
| 44185-50 | 50x72    | 85     |
| 44185-70 | 69x100   | 120    |

**MDF surface with wooden frame.**  
Lavagna in MDF con cornice in legno.

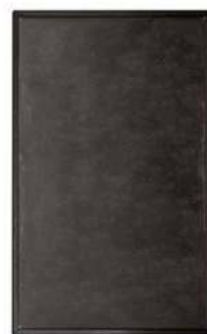

NEW

**Wall board**  
Lavagna da muro  
Wandtafel  
Tableau mural  
Pizarra murale

| art.     | dim. cm. |
|----------|----------|
| 44187-40 | 40x60    |
| 44187-60 | 60x80    |

**MDF surface. – Lavagna in MDF.**





**Ashtray**  
Posacenere  
Aschenbecher  
Cendrier  
Cenicero

| art.     | Ø cm. |
|----------|-------|
| 48247-10 | 10    |



**Ashtray**  
Posacenere  
Aschenbecher  
Cendrier  
Cenicero

| art.     | Ø cm. | h. cm. |
|----------|-------|--------|
| 48250-10 | 10    | 4,5    |
| 48250-12 | 12    | 4,5    |



**Ashtray**  
Posacenere  
Aschenbecher  
Cendrier  
Cenicero

| art.     | Ø cm. |
|----------|-------|
| 44366-10 | 10    |



**Ashtray, chrome plated**  
Posacenere, cromato  
Aschenbecher, Metall hartverchromt  
Cendrier, chromé  
Cenicero, cromado

| art.     | Ø cm. | h. cm. |
|----------|-------|--------|
| 48249-13 | 13    | 10,5   |



**Ashtray, 3 pcs set**  
Posacenere, set 3 pz  
Aschenbecher, 3 Stk  
Cendrier, set 3 pièces  
Cenicero, 3 pz

| art.     | Ø cm. | h. cm. | col. |
|----------|-------|--------|------|
| 48251-03 | 8     | 3      | ●    |



**Ashtray**  
Posacenere  
Aschenbecher  
Cendrier  
Cenicero

| art.     | Ø cm. | h. cm. | col. |
|----------|-------|--------|------|
| 48253B09 | 9,5   | 4,5    | ●    |



**Ashtray**  
Posacenere  
Aschenbecher  
Cendrier  
Cenicero

| art.     | Ø cm. | h. cm. | col. |
|----------|-------|--------|------|
| 48253-09 | 9,5   | 4,5    | ○    |



**Ashtray**  
Posacenere  
Aschenbecher  
Cendrier  
Cenicero

| art.     | Ø cm. | h. cm. | col. |
|----------|-------|--------|------|
| 48252-10 | 10    | 4,0    | ○    |
| 48252-12 | 12    | 4,5    | ○    |



**Ashtray**  
Posacenere  
Aschenbecher  
Cendrier  
Cenicero

| art.     | Ø cm. | h. cm. | col. |
|----------|-------|--------|------|
| 48252B10 | 10    | 4,0    | ●    |
| 48252B12 | 12    | 4,5    | ●    |



**Table cigar cutter**  
Tagliasigari da tavola  
Zigarrenscheider  
Coupe-cigares  
Guillotina para puros

| art.     | dim. cm. |
|----------|----------|
| 48244-07 | 9x4      |



**Table cigar cutter**  
Tagliasigari da tavola  
Zigarrenscheider  
Coupe-cigares  
Guillotina para puros

| art.     | dim. cm. |
|----------|----------|
| 48244-04 | 4x4      |



**Table cigar cutter**  
Tagliasigari da tavola  
Zigarrenscheider  
Coupe-cigares  
Guillotina para puros

| art.     | dim. cm. |
|----------|----------|
| 48242-09 | 9x4      |

Double blad. Assorted models. – Doppia lama.  
Modelli assortiti.





SS

**Cigar scissors**

Forbice sigari  
Zigarrenscher  
Ciseaux à cigares  
Cortador para puros

| art.     | dim. cm. |
|----------|----------|
| 48245-10 | 10x5     |



PMMA

W

**Cigar humidor**

Vetrina sigari  
Zigarren-Vitrine  
Vitrine à cigares  
Vitrina para puros

| art.     | dim. cm. |
|----------|----------|
| 48245-75 | 30x24x13 |

**With an incorporated hygrometre a small humidifier and liquid. Plexiglass window, cedar wood interior with two removable dividers. Can contain between 50 and 70 cigars according to the cigar ring. – Dotato di igrometro incorporato e un piccolo umidificatore oltre al liquido. Finestra in plexiglass interno di cedro con due divisori removibili. Capienza da 50 a 75 sigari in relazione al ring del sigaro.**



SS

**Cigar ashtray**

Portasigaro con piattino  
Aschenbecher mit Zigarrenhalter  
Cendrier à cigares  
Cenicero para puros

| art.     | Ø cm. |
|----------|-------|
| 48241-14 | 14,5  |



# PEUGEOT MILLS MACINE



TABLE TOP  
TAVOLA





MECHANISMS  
MECCANISMI



PEPPER



SALT



WET SEA SALT



LONG PEPPER



CHILI PEPPER



NUTMEG



CINNAMON



FLAX SEED

**PEPPER**

Made of case-hardened steel for higher, more consistent output with fewer turns. Equipped with a helix-shaped double row of teeth that guide and hold the peppercorns for a perfect grind. The grind is essential for unlocking the full flavour of your pepper. To get the best out of your pepper grinding mechanism, we recommend to use peppercorns with a diameter of 6 mm or less. Black, white and dry green peppercorns can be ground in Peugeot pepper mills. The pink berries can be ground only if in a blend (max 15% pink) with one of these peppercorns. Dried coriander is also suitable for the pepper mechanism.

**DRY SALT**

The Peugeot salt mechanism is designed to grind cooking salt (rock salt). It is made of a special stainless steel that resists corrosion. Its shape is specifically adapted to transform dry salt crystals to a fine powder. To get the best out of your Peugeot salt grinding mechanism, you should use salt with a size of 4 mm max.

**WET SEA SALT**

For wet sea salt, a specially designed mechanism has been created because the natural consistency and moisture content do not allow the use of an ordinary salt mill. An innovative patented system enables a high-performance grind without blockage even with very humid or compressed salt. This specific mechanism is composed of 3 fins ensuring both resistance and constant output, and of an spiral that mixes the salt and guides it, ensuring a constant flow. Exclusive ceramic mechanism.

**NUTMEG**

The Peugeot nutmeg mill is equipped with a double stainless steel blade/grater and a strong claw which enables the nutmeg to be very finely ground.

**CHILI PEPPER**

The chili pepper mechanism is a Peugeot exclusive product. This patented model has a pre-cutting system and a mechanism that grinds dry chili pepper. Like the pepper grinder it has a patented treatment that protects the steel from corrosion while maintaining its sharpness and wear resistance.

**PEPE**

Realizzato in acciaio, beneficia di un trattamento che lo protegge dalla corrosione, conserva il potere tranciante e lo rende resistente all'usura. Dotato di una doppia fila di denti elicoidali che guidano i grani di pepe verso il basso. Trancia e non schiaccia i grani, per sprigionarne sottilmente sapore e profumo. Consigliamo di utilizzare grani di pepe con un diametro di 6 mm o meno. I grani di pepe neri, bianchi e verdi secchi possono essere macinati nei macinapepe Peugeot. Le bacche rosa possono essere macinate solo se in miscela (max 15% rosa). Il meccanismo del pepe è adatto anche al coriandolo essiccato.

**SALE SECCO**

Il meccanismo del sale è progettato per macinare il sale da cucina (sale grosso). È fatto di un speciale acciaio inossidabile resistente alla corrosione. La sua forma è specificamente adattata per trasformare cristalli di sale secco in una polvere fine. Per un risultato ottimale si consiglia di usare sale con una dimensione di 4 mm max.

**SALE MARINO UMIDO**

Per il sale marino umido, è stato creato un meccanismo apposito. Un innovativo sistema brevettato consente una macinatura ad alte prestazioni senza ostruzioni anche con sale molto umido o compresso. Il meccanismo è composto da 3 alette che ne garantiscono sia la resistenza sia un rendimento costante, e di una spirale che mescola il sale e lo guida assicurandone un flusso costante. Meccanismo esclusivo in ceramica.

**NOCE MOSCATA**

La macina è dotata di una doppia lama per grattugiare in acciaio inox e di un robusto dischetto uncinato che permette di grattugiare l'intera noce molto finemente.

**PEPERONCINO**

Questo meccanismo è un prodotto esclusivo Peugeot. Il modello brevettato ha un sistema di pre-taglio e un meccanismo che permettono di macinare il peperoncino essiccato. Come il macinapepe, il meccanismo subisce un trattamento brevettato che protegge l'acciaio dalla corrosione pur mantenendo la sua affilatura e resistenza all'usura.





**ADJUSTABLE GRINDING SYSTEM**

For electric or manual mills.

Patented precision system that enables precise grind adjustment settings. 6 pre-defined levels of grind for pepper and 6 for salt. Rotate the ring at the base of the mill and select one of the positions, each corresponding to a specific grain.

**REGOLAZIONE DELLA MACINA**

Per macine manuali ed elettriche.

Sistema brevettato che permette una regolazione predefinita della macinatura. 6 Livelli per il pepe e 6 Livelli per il sale. Ruotare l'anello alla base della macina e selezionare una delle posizioni, ognuna corrisponde ad una determinata grana.



**CLASSIC ADJUSTABLE SYSTEM**

Thumbwheel grind adjustment on electric grinders is found below the grinding mechanism. Grind adjustment nut on manual mills, turn the nut. Clockwise to obtain a finger grind, counter-clockwise to obtain a coarser grind.

**REGOLAZIONE CLASSICA**

Negli apparecchi elettrici la rotella di regolazione si trova sotto il meccanismo di macinatura. Negli apparecchi manuali la regolazione si effettua ruotando il dado/pomolino. Ruotare in senso orario per ottenere una macinatura più fine, in senso antiorario per ottenere una macinatura più grossa.



PEPPER



SALT







W

SS

SELECT  
MOUTURE SUR MESURE

**PARIS ICÔNE Pepper/salt mill**

Macina pepe/sale  
Pfeffer-/Salzmühle  
Moulin à poivre/sel  
Molinillo pimienta/sal

| art.-P   | art.-S   | h. cm. |
|----------|----------|--------|
| 42687P18 | 42687S18 | 18     |
| 42687P22 | 42687S22 | 22     |

**Walnut. – Noce**



W

SS

SELECT  
MOUTURE SUR MESURE

**PARIS ICÔNE Pepper/salt mill**

Macina pepe/sale  
Pfeffer-/Salzmühle  
Moulin à poivre/sel  
Molinillo pimienta/sal

| art.-P   | art.-S   | h. cm. |
|----------|----------|--------|
| 42688P18 | 42688S18 | 18     |
| 42688P22 | 42688S22 | 22     |
| 42688P30 | 42688S30 | 30     |

**Laquered black. – Laccato nero.**



W

**PARIS ANTIQUE Pepper/salt mill**

Macina pepe/sale  
Pfeffer-/Salzmühle  
Moulin à poivre/sel  
Molinillo pimienta/sal

| art.-P   | art.-S   | h. cm. |
|----------|----------|--------|
| 42749P18 | 42749S18 | 18     |
| 42749P22 | 42749S22 | 22     |

**Beech wood antique. – Faggio anticato.**



W

SELECT  
MOUTURE SUR MESURE

**PARIS Pepper/salt mill**

Macina pepe/sale  
Pfeffer-/Salzmühle  
Moulin à poivre/sel  
Molinillo pimienta/sal

| art.-P   | art.-S   | h. cm. |
|----------|----------|--------|
| 42665P12 | 42665S12 | 12     |
| 42665P18 | 42665S18 | 18     |
| 42665P22 | 42665S22 | 22     |
| 42665P30 | 42665S30 | 30     |
| 42665P40 | 42665S40 | 40     |

**Beech wood, natural. – Faggio naturale.**



W

**PARIS Pepper/salt mill**  
Macina pepe/sale  
Pfeffer-/Salzmühle  
Moulin à poivre/sel  
Molinillo pimienta/sal

| art.-P   | art.-S   | h. cm. |
|----------|----------|--------|
| 42746P12 | -        | 12     |
| 42746P18 | 42746S18 | 18     |
| 42746P22 | 42746S22 | 22     |
| 42746P30 | 42746S30 | 30     |

**Beech wood, chocolate.** – Faggio cioccolato.



W

**PARIS Pepper/salt mill**  
Macina pepe/sale  
Pfeffer-/Salzmühle  
Moulin à poivre/sel  
Molinillo pimienta/sal

| art.-P   | art.-S | h. cm. |
|----------|--------|--------|
| 42746P40 | -      | 40     |
| 42746P50 | -      | 50     |
| 42746P80 | -      | 80     |

**Beech wood, chocolate.** – Faggio cioccolato.



W

**PARIS Pepper/salt mill**  
Macina pepe/sale  
Pfeffer-/Salzmühle  
Moulin à poivre/sel  
Molinillo pimienta/sal

| art.-P   | art.-S   | h. cm. |
|----------|----------|--------|
| 42747P12 | 42747S12 | 12     |
| 42747P18 | 42747S18 | 18     |

**Beech wood, black lacquered.**  
Faggio laccato nero.







NEW  
W

**PARIS OLIVE Pepper/salt mill**

Macina pepe/sale  
Pfeffer-/Salzmühle  
Moulin à poivre/sel  
Molinillo pimienta/sal

| art.-P   | art.-S   | h. cm. |
|----------|----------|--------|
| 42718P18 | 42718S18 | 18     |
| 42718P22 | 42718S22 | 22     |

Olive wood. – Ulivo.



W  
SELECT  
MOUTURE SUR MESURE

**PARIS Pepper/salt mill**

Macina pepe/sale  
Pfeffer-/Salzmühle  
Moulin à poivre/sel  
Molinillo pimienta/sal

| art.-P   | art.-S   | h. cm. |
|----------|----------|--------|
| 42666P12 | 42666S12 | 12     |
| 42666P18 | 42666S18 | 18     |
| 42666P22 | 42666S22 | 22     |
| 42666P27 | 42666S27 | 27     |
| 42666P30 | 42666S30 | 30     |
| 42666P40 | 42666S40 | 40     |

Beech wood, chocolate. – Faggio cioccolato.



W  
SELECT  
MOUTURE SUR MESURE

**PARIS Pepper/salt mill**

Macina pepe/sale  
Pfeffer-/Salzmühle  
Moulin à poivre/sel  
Molinillo pimienta/sal

| art.-P   | art.-S   | h. cm. |
|----------|----------|--------|
| 42668P12 | 42668S12 | 12     |
| 42668P18 | 42668S18 | 18     |
| 42668P22 | 42668S22 | 22     |
| 42668P30 | 42668S30 | 30     |
| 42668P40 | -        | 40     |

Beech wood, red lacquered.  
Faggio laccato rosso.



**PARIS GRAPHITE Pepper/salt mill**

Macina pepe/sale  
Pfeffer-/Salzmühle  
Moulin à poivre/sel  
Molinillo pimienta/sal

| art.-P   | art.-S   | h. cm. |
|----------|----------|--------|
| 42721P18 | 42721S18 | 18     |
| 42721P22 | 42721S22 | 22     |
| 42721P30 | 42721S30 | 30     |

**Beech wood graphite.** – Faggio grafite.



**PARIS Pepper/salt mill**

Macina pepe/sale  
Pfeffer-/Salzmühle  
Moulin à poivre/sel  
Molinillo pimienta/sal

| art.-P   | art.-S   | h. cm. |
|----------|----------|--------|
| 42667P12 | 42667S12 | 12     |
| 42667P18 | 42667S18 | 18     |
| 42667P22 | 42667S22 | 22     |
| 42667P30 | 42667S30 | 30     |

**Beech wood, black lacquered.**  
Faggio laccato nero.



**PARIS Pepper/salt mill**

Macina pepe/sale  
Pfeffer-/Salzmühle  
Moulin à poivre/sel  
Molinillo pimienta/sal

| art.-P   | art.-S   | h. cm. |
|----------|----------|--------|
| 42664P12 | 42664S12 | 12     |
| 42664P18 | 42664S18 | 18     |
| 42664P22 | 42664S22 | 22     |
| 42664P30 | 42664S30 | 30     |
| 42664P40 | -        | 40     |

**Beech wood, white lacquered.**  
Faggio laccato bianco.



**PARIS CHEF Pepper/salt mill**

Macina pepe/sale  
Pfeffer-/Salzmühle  
Moulin à poivre/sel  
Molinillo pimienta/sal

| art.-P   | art.-S   | h. cm. |
|----------|----------|--------|
| 42674P18 | 42674S18 | 18     |
| 42674P22 | 42674S22 | 22     |
| 42674P30 | 42674S30 | 30     |



**BISTRO CHEF Pepper/salt mill**

Macina pepe/sale  
Pfeffer-/Salzmühle  
Moulin à poivre/sel  
Molinillo pimienta/sal

| art.-P   | art.-S   | h. cm. |
|----------|----------|--------|
| 42624P10 | 42624S10 | 10     |



**BISTRO Pepper/salt mill**

Macina pepe/sale  
Pfeffer-/Salzmühle  
Moulin à poivre/sel  
Molinillo pimienta/sal

| art.-P   | art.-S   | h. cm. |
|----------|----------|--------|
| 42701-10 | 42703-10 | 10     |

**Beech wood, natural.** – Faggio naturale.



**BISTRO Pepper/salt mill**

Macina pepe/sale  
Pfeffer-/Salzmühle  
Moulin à poivre/sel  
Molinillo pimienta/sal

| art.-P   | art.-S   | h. cm. |
|----------|----------|--------|
| 42701P10 | 42703S10 | 10     |

**Beech wood, white matt.** – Faggio bianco opaco.







W

**BISTRO Pepper/salt mill**

Macina pepe/sale  
Pfeffer-/Salzmühle  
Moulin à poivre/sel  
Molinillo pimienta/sal

| art.-P   | art.-S   | h. cm. |
|----------|----------|--------|
| 42702-10 | 42704-10 | 10     |

**Beech wood, chocolate.** – Faggio cioccolato.



W

**BISTRO Pepper/salt mill**

Macina pepe/sale  
Pfeffer-/Salzmühle  
Moulin à poivre/sel  
Molinillo pimienta/sal

| art.-P   | art.-S   | h. cm. |
|----------|----------|--------|
| 42702P10 | 42704S10 | 10     |

**Beech wood, black matt.** – Faggio nero opaco.



W

**BISTRO ANTIQUE Pepper/salt mill**

Macina pepe/sale  
Pfeffer-/Salzmühle  
Moulin à poivre/sel  
Molinillo pimienta/sal

| art.-P   | art.-S   | h. cm. |
|----------|----------|--------|
| 42705P10 | 42705S10 | 10     |

**Beech wood antique.** – Faggio anticato.



NEW

W

**BISTRO GRAPHITE Pepper/salt mill**

Macina pepe/sale  
Pfeffer-/Salzmühle  
Moulin à poivre/sel  
Molinillo pimienta/sal

| art.-P   | art.-S   | h. cm. |
|----------|----------|--------|
| 42713P10 | 42713S10 | 10     |

**Beech wood graphite.** – Faggio grafite.



NEW

W

**BISTRO OLIVE Pepper/salt mill**

Macina pepe/sale  
Pfeffer-/Salzmühle  
Moulin à poivre/sel  
Molinillo pimienta/sal

| art.-P   | art.-S   | h. cm. |
|----------|----------|--------|
| 42714P10 | 42714S10 | 10     |

**Olive wood.** – Ulivo.



W

**CHÂTEL Pepper/salt mill**

Macina pepe/sale  
Pfeffer-/Salzmühle  
Moulin à poivre/sel  
Molinillo pimienta/sal

| art.-P   | art.-S   | h. cm. |
|----------|----------|--------|
| 42707P21 | 42707S21 | 21     |

**Walnut.** – Noce.



W

**HOSTELLERIE Pepper mill**

Macina pepe  
Pfeffermühle  
Moulin à poivre  
Molinillo pimienta

| art.     | h. cm. | col. |
|----------|--------|------|
| 42741-22 | 22     | ●    |
| 42742-22 | 22     | ●    |

**Natural & chocolate.** – Naturale & cioccolato.



W

SS

**ISEN Pepper mill/salt mill**

Macina pepe/sale  
Pfeffer-/Salzmühle  
Moulin à poivre/sel  
Molinillo pimienta/sal

| art.-P   | art.-S   | h. cm. |
|----------|----------|--------|
| 42682P18 | 42682S18 | 18     |

**Beech wood, black matt.** – Faggio nero opaco.



W  
SS

**ISEN Pepper mill/salt mill**

Macina pepe/sale  
Pfeffer-/Salzmühle  
Moulin à poivre/sel  
Molinillo pimienta/sal

art.-P art.-S h. cm.  
42683P18 42683S18 18

**Beech wood, natural.** – Faggio naturale.



W  
SS

**ROYAN Pepper/salt mill**

Macina pepe/sale  
Pfeffer-/Salzmühle  
Moulin à poivre/sel  
Molinillo pimienta/sal

art.-P art.-S h. cm.  
42677P14 42677S14 14

**Beech wood. Metallic finish that reveals the wood's grains.** – Faggio. Finitura metallica che rivela le venature del legno.



W

**MERIBEL Pepper mill**

Macina pepe  
Pfeffermühle  
Moulin à poivre  
Molinillo pimienta

art.-P art.-S h. cm.  
42685P14 42685S14 14

**Walnut. Cap highly matt finish, body brilliant finish in an acrylic envelope protecting the wood against humidity.** – Noce. Testa finitura opaca, corpo finitura brillante racchiuso in acrilico che protegge il legno dall'umidità.



NEW  
W  
SS

**FIDJI GRAPHITE Pepper/salt mill**

Macina pepe/sale  
Pfeffer-/Salzmühle  
Moulin à poivre/sel  
Molinillo pimienta/sal

art.-P art.-S h. cm.  
42655P15 42655S15 15

**Beech wood graphite.** – Faggio grafite.



W  
SS

**FIDJI OLIVE Pepper/salt mill**

Macina pepe/sale  
Pfeffer-/Salzmühle  
Moulin à poivre/sel  
Molinillo pimienta/sal

art.-P art.-S h. cm.  
42676P15 42676S15 15  
42676P20 42676S20 20

**Olive wood.** – Ulivo.



W  
SS

**FIDJI Pepper/salt mill**

Macina pepe/sale  
Pfeffer-/Salzmühle  
Moulin à poivre/sel  
Molinillo pimienta/sal

art.-P art.-S h. cm.  
42676P12 42676S12 12  
42676P15 42676S15 15  
42676P20 42676S20 20

**Beech wood, black matt.** – Faggio nero opaco.





**BALI FONTE Pepper mill**

Macina pepe  
Pfeffermühle  
Moulin à poivre  
Molinillo pimienta

| art.     | h. cm. | col. |
|----------|--------|------|
| 42620P03 | 8      | ●    |
| 42620P01 | 8      | ●    |
| 42620P02 | 8      | ●    |

Cast iron. – Ghisa.



W

**BAYA Pepper/salt mill**

Macina pepe/sale  
Pfeffer-/Salzmühle  
Moulin à poivre/sel  
Molinillo pimienta/sal

| art.-P   | art.-S   | h. cm. |
|----------|----------|--------|
| 42684P08 | 42684S08 | 8      |

Chocolate & natural. – Cioccolato & naturale.



ABS  
AY

**BALI Pepper mill**

Macina pepe  
Pfeffermühle  
Moulin à poivre  
Molinillo pimienta

| art.     | h. cm. | col. |
|----------|--------|------|
| 42661-02 | 8      | ●    |
| 42661-03 | 8      | ●    |



ABS  
AY

**BALI Salt mill**

Macina sale  
Salzmühle  
Moulin à sel  
Molinillo sal

| art.     | h. cm. | col. |
|----------|--------|------|
| 42661-06 | 8      | ○    |



ABS  
AY

**BRASSERIE Duo, pepper/salt mill**

Duo, macinapepe/sale  
Duo, Pfeffer-/Salzmühle  
Duo, moulin à poivre/sel  
Duo, molinillo pimienta/sal

| art.     | h. cm. |
|----------|--------|
| 42710-11 | 11     |

Chromed. – Cromato.



AY  
SS

**DAMAN Pepper/salt mill**

Macina pepe/sale  
Pfeffer-/Salzmühle  
Moulin à poivre/sel  
Molinillo pimienta/sal

| art.-P   | art.-S   | h. cm. |
|----------|----------|--------|
| 42764P16 | 42764S16 | 16     |
| 42764P21 | 42764S21 | 21     |

SELECT  
MOÛTURE SUR MESURE



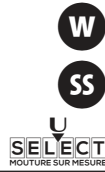

**MADRAS Pepper/salt mill**

Macina pepe/sale  
Pfeffer-/Salzmühle  
Moulin à poivre/sel  
Molinillo pimienta/sal

art.-P art.-S h. cm.  
42705P16 42705S16 16  
42705P21 42705S21 21

**Beech wood chocolate.** – Faggio cioccolato.



**MADRAS GRAPHITE Pepper/salt mill**

Macina pepe/sale  
Pfeffer-/Salzmühle  
Moulin à poivre/sel  
Molinillo pimienta/sal

art.-P art.-S h. cm.  
42717P16 42717S16 16

**Beech wood graphite.** – Faggio grafite.



**CHAUMONT Pepper/salt mill**

Macina pepe/sale  
Pfeffer-/Salzmühle  
Moulin à poivre/sel  
Molinillo pimienta/sal

art.-P art.-S h. cm.  
42798P11 42798S11 11



**VITTEL Pepper/salt mill**

Macina pepe/sale  
Pfeffer-/Salzmühle  
Moulin à poivre/sel  
Molinillo pimienta/sal

art.-P art.-S h. cm.  
42796P16 42796S16 16  
42796P23 42796S23 23



**NANCY Wet sea salt mill**

Macina per sale umido  
Mühle für Feuchtes Meersalz  
Moulin à sel humide  
Molinillo sal húmeda

art. h. cm.  
42728S18 18



**NANCY Pepper/salt mill**

Macina pepe/sale  
Pfeffer-/Salzmühle  
Moulin à poivre/sel  
Molinillo pimienta/sal

art.-P art.-S h. cm.  
42727-09 42728-09 9  
42727-12 42728-12 12  
42727-18 42728-18 18



**NANCY Pepper/salt mill**

Macina pepe/sale  
Pfeffer-/Salzmühle  
Moulin à poivre/sel  
Molinillo pimienta/sal

art.-P art.-S h. cm.  
42727-22 42728-22 22  
42727-30 42728-30 30  
42727-38 42728-38 38







AY  
W

**OLERON Wet sea salt mill**  
Macina per sale umido  
Mühle für Feuchtes Meersalz  
Moulin à sel humide  
Molinillo sal húmeda

art. h. cm.  
42670N14 14

**Beech wood.** – Faggio.



AY  
W

**OLERON Wet sea salt mill**  
Macina per sale umido  
Mühle für Feuchtes Meersalz  
Moulin à sel humide  
Molinillo sal húmeda

art. h. cm.  
42670B14 14

**Beech wood.** – Faggio.



AY

**MOLENE Wet sea salt mill**  
Macina per sale umido  
Mühle für Feuchtes Meersalz  
Moulin à sel humide  
Molinillo sal húmeda

art. h. cm.  
42670W14 14

**White.** – Bianco.



AY  
SS

**OSLO Wet sea salt mill**  
Macina per sale umido  
Mühle für Feuchtes Meersalz  
Moulin à sel humide  
Molinillo sal húmeda

art. h. cm.  
42678W14 14



AY  
SS

**OSLO Pepper/salt mill**  
Macina pepe/sale  
Pfeffer-/Salzmühle  
Moulin à poivre/sel  
Molinillo pimienta/sal

art.-P art.-S h. cm.  
42678P14 42678S14 14



NEW

AY  
W

**OSLO GRAPHITE Pepper/salt mill**  
Macina pepe/sale  
Pfeffer-/Salzmühle  
Moulin à poivre/sel  
Molinillo pimienta/sal

art.-P art.-S h. cm.  
42679P12 42679S12 12

**Beech wood graphite.** – Faggio grafite.





AY  
W

**OLERON Pepper/salt mill**

Macina pepe/sale  
Pfeffer-/Salzmühle  
Moulin à poivre/sel  
Molinillo pimienta/sal

art.-P art.-S h. cm.  
42662P14 42662S14 14

**Beech wood.** – Faggio.



AY  
W

**OLERON Herbs/chili mill**

Macina erbe/peperoncino  
Kräuter-/Paprikamühle  
Moulin à herbes/piment  
Molinillo hierbas/chile

art. h. cm.  
42662C14 14

**Beech wood.** – Faggio.



AY  
SS

**OUESSANT Pepper/salt mill**

Macina pepe/sale  
Pfeffer-/Salzmühle  
Moulin à poivre/sel  
Molinillo pimienta/sal

art.-P art.-S h. cm.  
42669P14 42669S14 14



AY  
SS

**OUESSANT Herbs/chili mill**

Macina erbe/peperoncino  
Kräuter-/Paprikamühle  
Moulin à herbes/piment  
Molinillo hierbas/chile

art. h. cm.  
42669C14 14



AY  
W

**OLERON Pepper/salt mill**

Macina pepe/sale  
Pfeffer-/Salzmühle  
Moulin à poivre/sel  
Molinillo pimienta/sal

art.-P art.-S h. cm.  
42663P14 42663S14 14

**Beech wood.** – Faggio.



AY  
W

**OLERON Herbs/chili mill**

Macina erbe/peperoncino  
Kräuter-/Paprikamühle  
Moulin à herbes/piment  
Molinillo hierbas/chile

art. h. cm.  
42663C14 14

**Beech wood.** – Faggio.



NEW  
W

**ISEN Nutmeg mill**

Macina noce moscata  
Muskatmühle  
Moulin à mouscade  
Molinillo nuez moscada

art. h. cm. col.  
42689-15 15 ●  
42690-15 15 ●

**Natural & black matt.** – Naturale & nero opaco.





SS  
AY

**DAMAN Nutmeg mill**  
Macina noce moscata  
Muskatmühle  
Moulin à mouscade  
Molinillo nuez moscada

art. h. cm.  
42764M15 15

**Magnetic stopper. Compartment for 3 nutmegs.**  
Tappo magnetico. Scompartimento per 3 noci.



W  
AY

**MADRAS Nutmeg mill**  
Macina noce moscata  
Muskatmühle  
Moulin à mouscade  
Molinillo nuez moscada

art. h. cm.  
42705M15 15

**Beech wood chocolate. Magnetic stopper. Compartment for 3 nutmegs.** – Faggio cioccolato. Tappo magnetico. Scompartimento per 3 noci.



AY  
ABS

**TERNATE Nutmeg mill**  
Macina noce moscata  
Muskatmühle  
Moulin à mouscade  
Molinillo nuez moscada

art. h. cm.  
42720-01 11

**Chromed. Compartment for 7/8 nutmegs.**  
Cromata. Serbatoio per 7/8 noci.



AG  
W

**PALACE Pepper/salt mill**  
Macina pepe/sale  
Pfeffer-/Salzmühle  
Moulin à poivre/sel  
Molinillo pimienta/sal

art.-P art.-S h. cm.  
42725P10 42725S10 10



AG

**MIGNONNETTE Pepper/salt mill**  
Macina pepe/sale  
Pfeffer-/Salzmühle  
Moulin à poivre/sel  
Molinillo pimienta/sal

art.-P art.-S h. cm.  
42723P10 42723S10 10



AY  
PC  
  

**ALASKA Duo, electric pepper/salt mill**  
Duo, macina pepe/sale, elettrici  
Duo, Pfeffer-/Salzmühle  
Duo, moulin à poivre/sel  
Duo, molinillo pimienta/sal

art. h. cm.  
42660-02 17



ABS  
  

**ZELI Pepper/salt mill**  
Macina pepe/sale  
Pfeffer-/Salzmühle  
Moulin à poivre/sel  
Molinillo pimienta/sal

art.-P art.-S h. cm.  
42801P14 42801S14 14

**Stainless steel look.** – Imitazione inox.



SS  
  
  
  
**SELECT**  
MOUTURE SUR MESURE

**ELIS SENSE Pepper/salt mill**  
Macina pepe/sale  
Pfeffer-/Salzmühle  
Moulin à poivre/sel  
Molinillo pimienta/sal

art.-P art.-S h. cm.  
42785S20 42786S20 20

**With small dish and spice vial with funnel.**  
Con vassoietto e fiala dosatrice con imbuto.





SS

**LANKA Cinnamon shaker/mill**

Macina & spargi cannella  
Zimt Shaker-/Mühle  
Shaker et moulin à cannelle  
Especiero y molinillo de canela

art. h. cm.

42685-22 22-7

**To grind cinnamon sticks (6 cm max). Shaker and mill function.** – Per macinare bastoncini di cannella (max 6 cm). Funzione shaker e macina.



W

SS

**ISEN Flax seeds mill**

Macina semi lino/sesamo  
Leinsamen-Mühle  
Moulin à graines de lin  
Molino de semillas de lino

art. h. cm.

42680-13 13

**Supplied with spoon of 5 g. and brush.**  
Fornito con un cucchiaino da 5 g. e scovolino.



W

SS

**ISEN Long pepper mill**

Macina pepe lungo  
Langer Pfeffermühle  
Moulin à poivres longs  
Molinillo de pimienta larga

art. h. cm.

42681-16 16

**To grind long pepper and very large peppercorns. Adjustable grinding. Comes with cleaning brush. Also works for cardamom, star anise, tonka beans, cloves, coriander.** – Per macinare pepe lungo e grani di pepe molto grandi. Regolabile. Fornito con scovolino. Funziona anche con cardamomo, anice stellato, fave tonka, chiodi di garofano, coriandolo.





# PEUGEOT APPOLIA



NEW

TABLE TOP  
TAVOLA



## ENAMELLED STONEWARE GRES SMALTATO



FACILE DA PULIRE

With the range of Appolia vitrified enamel ceramics, Peugeot demonstrates its know-how and expertise in the field of oven dishes.



COLORE E BRILLANTEZZA  
DI LUNGA DURATA

It is in France, in the heart of Brittany, in its ceramic factory founded more than 80 years ago, that Peugeot produces Appolia products. The workshop has awarded the EPV label "Entreprise du Patrimoine Vivant" - a sign of recognition by the State that distinguishes French companies with excellent craftsmanship and industrial know-how.



SUPERFICIE ULTRA  
LISCIA ANTIABRASIONE

A noble material, Peugeot ceramic guarantees regular and homogeneous cooking for a healthy and tasty cuisine. A well-kept secret, the recipe for ceramic paste, a mix of clay, kaolin and feldspar, gives the product a remarkable resistance to mechanical shocks.

Simple and contemporary lines, Appolia has been designed to offer practicality and express flavors.

Con la gamma di ceramiche smaltate Appolia, Peugeot dimostra il suo know-how e la sua competenza nel campo delle pirofile da forno.

È in Francia, nel cuore della Bretagna, nella sua manifattura di ceramica fondata da più di 80 anni, che Peugeot produce i prodotti Appolia. L'officina è stata premiata con l'etichetta EPV "Entreprise du Patrimoine Vivant" - un segno di riconoscimento da parte dello Stato che distingue le aziende francesi con un'eccellente know-how artigianale e industriale.

Un materiale nobile, la ceramica Peugeot garantisce una cottura regolare e omogenea per una cucina sana e gustosa. Un segreto ben custodito, la ricetta della pasta ceramica, un mix di argilla, caolino e feldspato, conferisce al prodotto una notevole resistenza agli urti meccanici.

Linee pulite e contemporanee, Appolia è stata progettata per offrire praticità ed esprimere i sapori.



Appolia dishes are suitable for use in the oven (250°C), microwave, freezer (-20°C). Dishwasher safe. Produced with 100% natural ingredients (mixture of clays, kaolin, silica, feldspar), 100% recyclable. They guarantee a delicate and tasty, healthy and homogeneous cooking. They have exceptional thermal inertia: they retain heat for up to 30 minutes - they help keep food hot or cold. The material is not porous, does not absorb odors, greases or liquids. The hardness of the final product gives the oven dishes a high mechanical resistance to shocks, scratches and acids. The resistance of Peugeot vitrified enamel has been tested by an independent laboratory. Easy to clean with a simple sponge. Long-lasting color and shine. Comfortable and easy to use, wide and striped handles for a secure grip; rounded corners, facilitate service and cleaning; deep, they offer more volume; allow the retention of cooking juices in order to preserve all the flavors, they are stackable one inside the other to save space. A collection for every day, beautiful, durable and versatile from the kitchen to the table. Available in 6 colors: red, ecru, blue - timeless and essential shades; slate, eggplant, terracotta - contemporary and chic shades

Le pirofile Appolia sono idonee all'uso in forno (250°C), microonde, congelatore (-20°C). Lavabili in lavastoviglie. Prodotte con ingredienti naturali al 100% (miscela di argille, caolino, silice, feldspato), 100% riciclabili. Garantiscono una cottura delicata e gustosa, sana e omogenea. Hanno eccezionale inerzia termica: trattengono il calore fino a 30 minuti - aiutano a mantenere il cibo caldo o freddo. Il materiale non è poroso, non assorbe odori, grassi o liquidi. La durezza del prodotto finale conferisce alle pirofile un'elevata resistenza meccanica agli urti, graffi e acidi. La resistenza dello smalto vetrificato di Peugeot è stata testata da un laboratorio indipendente. Facile da pulire con una semplice spugna. Colore e brillantezza di lunga durata. Comode e facili da usare, maniglie larghe e striate per una presa sicura; angoli arrotondati, facilitano il servizio e la pulizia; profonde, offrono più volume; consentono la ritenzione dei succhi di cottura in modo da preservare tutti i sapori, sono impilabili l'una nell'altra per un risparmio di spazio. Una collezione per tutti i giorni, bella, durevole e versatile dalla cucina alla tavola. Disponibile in 6 colori: rosso, ecru, blu - tonalità senza tempo ed essenziali; ardesia, melanzana, terracotta - tonalità contemporanee e chic.





**Rectangular baker**

Pirofila Rettangolare  
Rechteckige Ofenschale  
Plat four rectangulaire  
Plato horno rectangular

| art.     | cm. int.    | cm. est.    | lt. | Kg. |
|----------|-------------|-------------|-----|-----|
| 44701B25 | 20x15,5x5,5 | 25x16,8x6,2 | 1,4 | 0,9 |
| 44701B32 | 26x20x6,5   | 32x21,7x7,2 | 2,7 | 1,7 |
| 44701B40 | 33x25,7x7,5 | 40x27,2x8,3 | 5,2 | 2,8 |



**Rectangular baker**

Pirofila Rettangolare  
Rechteckige Ofenschale  
Plat four rectangulaire  
Plato horno rectangular

| art.     | cm. int.    | cm. est.    | lt. | Kg. |
|----------|-------------|-------------|-----|-----|
| 44701C25 | 20x15,5x5,5 | 25x16,8x6,2 | 1,4 | 0,9 |
| 44701C32 | 26x20x6,5   | 32x21,7x7,2 | 2,7 | 1,7 |
| 44701C40 | 33x25,7x7,5 | 40x27,2x8,3 | 5,2 | 2,8 |



**Rectangular baker**

Pirofila Rettangolare  
Rechteckige Ofenschale  
Plat four rectangulaire  
Plato horno rectangular

| art.     | cm. int.    | cm. est.    | lt. | Kg. |
|----------|-------------|-------------|-----|-----|
| 44701M25 | 20x15,5x5,5 | 25x16,8x6,2 | 1,4 | 0,9 |
| 44701M32 | 26x20x6,5   | 32x21,7x7,2 | 2,7 | 1,7 |
| 44701M40 | 33x25,7x7,5 | 40x27,2x8,3 | 5,2 | 2,8 |



**Rectangular baker**

Pirofila Rettangolare  
Rechteckige Ofenschale  
Plat four rectangulaire  
Plato horno rectangular

| art.     | cm. int.    | cm. est.    | lt. | Kg. |
|----------|-------------|-------------|-----|-----|
| 44701R25 | 20x15,5x5,5 | 25x16,8x6,2 | 1,4 | 0,9 |
| 44701R32 | 26x20x6,5   | 32x21,7x7,2 | 2,7 | 1,7 |
| 44701R40 | 33x25,7x7,5 | 40x27,2x8,3 | 5,2 | 2,8 |





**Rectangular baker**  
Pirofila Rettangolare  
Rechteckige Ofenschale  
Plat four rectangulaire  
Plato horno rectangular

| art.     | cm. int.    | cm. est.    | lt. | Kg. |
|----------|-------------|-------------|-----|-----|
| 44701S25 | 20x15,5x5,5 | 25x16,8x6,2 | 1,4 | 0,9 |
| 44701S32 | 26x20x6,5   | 32x21,7x7,2 | 2,7 | 1,7 |
| 44701S40 | 33x25,7x7,5 | 40x27,2x8,3 | 5,2 | 2,8 |



**Rectangular baker**  
Pirofila Rettangolare  
Rechteckige Ofenschale  
Plat four rectangulaire  
Plato horno rectangular

| art.     | cm. int.    | cm. est.    | lt. | Kg. |
|----------|-------------|-------------|-----|-----|
| 44701T25 | 20x15,5x5,5 | 25x16,8x6,2 | 1,4 | 0,9 |
| 44701T32 | 26x20x6,5   | 32x21,7x7,2 | 2,7 | 1,7 |
| 44701T40 | 33x25,7x7,5 | 40x27,2x8,3 | 5,2 | 2,8 |



**Square baker**  
Pirofila Quadra  
Quadratische Ofenschale  
Plat four carré  
Plato horno cuadrado

| art.     | cm. int.      | cm. est.    | lt. | Kg. |
|----------|---------------|-------------|-----|-----|
| 44702B21 | 16,3x16,3x5,4 | 21x17,5x6   | 1,1 | 0,8 |
| 44702B28 | 22,5x22,5x6,5 | 28x23,7x7,2 | 2,7 | 1,6 |
| 44702B36 | 29,5x29,5x7,5 | 36x31x8,2   | 5,4 | 2,8 |



**Square baker**  
Pirofila Quadra  
Quadratische Ofenschale  
Plat four carré  
Plato horno cuadrado

| art.     | cm. int.      | cm. est.    | lt. | Kg. |
|----------|---------------|-------------|-----|-----|
| 44702C21 | 16,3x16,3x5,4 | 21x17,5x6   | 1,1 | 0,8 |
| 44702C28 | 22,5x22,5x6,5 | 28x23,7x7,2 | 2,7 | 1,6 |
| 44702C36 | 29,5x29,5x7,5 | 36x31x8,2   | 5,4 | 2,8 |







**Square baker**

Pirofila Quadra  
Quadratische Ofenschale  
Plat four carré  
Plato horno cuadrado

| art.     | cm. int.      | cm. est.    | lt. | Kg. |
|----------|---------------|-------------|-----|-----|
| 44702M21 | 16,3x16,3x5,4 | 21x17,5x6   | 1,1 | 0,8 |
| 44702M28 | 22,5x22,5x6,5 | 28x23,7x7,2 | 2,7 | 1,6 |
| 44702M36 | 29,5x29,5x7,5 | 36x31x8,2   | 5,4 | 2,8 |

**Square baker**

Pirofila Quadra  
Quadratische Ofenschale  
Plat four carré  
Plato horno cuadrado

| art.     | cm. int.      | cm. est.    | lt. | Kg. |
|----------|---------------|-------------|-----|-----|
| 44702R21 | 16,3x16,3x5,4 | 21x17,5x6   | 1,1 | 0,8 |
| 44702R28 | 22,5x22,5x6,5 | 28x23,7x7,2 | 2,7 | 1,6 |
| 44702R36 | 29,5x29,5x7,5 | 36x31x8,2   | 5,4 | 2,8 |



**Square baker**

Pirofila Quadra  
Quadratische Ofenschale  
Plat four carré  
Plato horno cuadrado

| art.     | cm. int.      | cm. est.    | lt. | Kg. |
|----------|---------------|-------------|-----|-----|
| 44702S21 | 16,3x16,3x5,4 | 21x17,5x6   | 1,1 | 0,8 |
| 44702S28 | 22,5x22,5x6,5 | 28x23,7x7,2 | 2,7 | 1,6 |
| 44702S36 | 29,5x29,5x7,5 | 36x31x8,2   | 5,4 | 2,8 |

**Square baker**

Pirofila Quadra  
Quadratische Ofenschale  
Plat four carré  
Plato horno cuadrado

| art.     | cm. int.      | cm. est.    | lt. | Kg. |
|----------|---------------|-------------|-----|-----|
| 44702T21 | 16,3x16,3x5,4 | 21x17,5x6   | 1,1 | 0,8 |
| 44702T28 | 22,5x22,5x6,5 | 28x23,7x7,2 | 2,7 | 1,6 |
| 44702T36 | 29,5x29,5x7,5 | 36x31x8,2   | 5,4 | 2,8 |



**Round baker**  
Pirofila Tonda  
Runde Ofenschale  
Plat four rond  
Plato horno redondo

| art.     | Ø cm. | h. cm. | cm. est.    | lt. | Kg.  |
|----------|-------|--------|-------------|-----|------|
| 44703B27 | 23    | 6      | 27x23,4x6,7 | 2,1 | 1,15 |
| 44703B34 | 30    | 7      | 34x29,5x7,7 | 3,8 | 2,1  |

**Round baker**  
Pirofila Tonda  
Runde Ofenschale  
Plat four rond  
Plato horno redondo

| art.     | Ø cm. | h. cm. | cm. est.    | lt. | Kg.  |
|----------|-------|--------|-------------|-----|------|
| 44703C27 | 23    | 6      | 27x23,4x6,7 | 2,1 | 1,15 |
| 44703C34 | 30    | 7      | 34x29,5x7,7 | 3,8 | 2,1  |







**Round baker**

Pirofila Tonda  
Runde Ofenschale  
Plat four rond  
Plato horno redondo

| art.     | Ø cm. | h. cm. | cm. est.    | lt. | Kg.  |
|----------|-------|--------|-------------|-----|------|
| 44703R27 | 23    | 6      | 27x23,4x6,7 | 2,1 | 1,15 |
| 44703R34 | 30    | 7      | 34x29,5x7,7 | 3,8 | 2,1  |



**Round baker**

Pirofila Tonda  
Runde Ofenschale  
Plat four rond  
Plato horno redondo

| art.     | Ø cm. | h. cm. | cm. est.    | lt. | Kg.  |
|----------|-------|--------|-------------|-----|------|
| 44703S27 | 23    | 6      | 27x23,4x6,7 | 2,1 | 1,15 |
| 44703S34 | 30    | 7      | 34x29,5x7,7 | 3,8 | 2,1  |



**Bread pan with lid**

Stampo Pane Con Coperchio  
Brotform Mit Deckel  
Plaque multipains avec couvercle  
Plato panadero con tapa

| art.     | cm. int. | cm. est.      | Kg. |
|----------|----------|---------------|-----|
| 44705C37 | 31,5x21  | 37,5x22,7x7,5 | 3   |



**Oval baker**

Pirofila Ovale  
Ovale Ofenschale  
Plat four ovale  
Plato horno ovalado

| art.     | cm. int.      | cm. est.    | lt. | Kg. |
|----------|---------------|-------------|-----|-----|
| 44706B31 | 27x20x6       | 31x21,5x7   | 2,2 | 1,4 |
| 44706B40 | 34,5x25,5x7,5 | 40x27,2x8,2 | 4,5 | 2,4 |



**Oval baker**

Pirofila Ovale  
Ovale Ofenschale  
Plat four ovale  
Plato horno ovalado

| art.     | cm. int.      | cm. est.    | lt. | Kg. |
|----------|---------------|-------------|-----|-----|
| 44706C31 | 27x20x6       | 31x21,5x7   | 2,2 | 1,4 |
| 44706C40 | 34,5x25,5x7,5 | 40x27,2x8,2 | 4,5 | 2,4 |







**Oval baker**

Pirofila Ovale  
Ovale Ofenschale  
Plat four ovale  
Plato horno ovalado

| art.     | cm. int.      | cm. est.    | lt. | Kg. |
|----------|---------------|-------------|-----|-----|
| 44706R31 | 27x20x6       | 31x21,5x7   | 2,2 | 1,4 |
| 44706R40 | 34,5x25,5x7,5 | 40x27,2x8,2 | 4,5 | 2,4 |

**Oval baker**

Pirofila Ovale  
Ovale Ofenschale  
Plat four ovale  
Plato horno ovalado

| art.     | cm. int.      | cm. est.    | lt. | Kg. |
|----------|---------------|-------------|-----|-----|
| 44706S31 | 27x20x6       | 31x21,5x7   | 2,2 | 1,4 |
| 44706S40 | 34,5x25,5x7,5 | 40x27,2x8,2 | 4,5 | 2,4 |



**Meat pie dish**

Pirofila Tonda  
Fleischpastete Ofenschale  
Plat four rond  
Plato horno redondo

| art.     | Ø cm. | h. cm. | cm. est.    | lt. | Kg. |
|----------|-------|--------|-------------|-----|-----|
| 44708B28 | 28    | 4,5    | 33x28,3x5,4 | 2,2 | 1,5 |

**Meat pie dish**

Pirofila Tonda  
Fleischpastete Ofenschale  
Plat four rond  
Plato horno redondo

| art.     | Ø cm. | h. cm. | cm. est.    | lt. | Kg. |
|----------|-------|--------|-------------|-----|-----|
| 44708C28 | 28    | 4,5    | 33x28,3x5,4 | 2,2 | 1,5 |

**Meat pie dish**

Pirofila Tonda  
Fleischpastete Ofenschale  
Plat four rond  
Plato horno redondo

| art.     | Ø cm. | h. cm. | cm. est.    | lt. | Kg. |
|----------|-------|--------|-------------|-----|-----|
| 44708R28 | 28    | 4,5    | 33x28,3x5,4 | 2,2 | 1,5 |

**Meat pie dish**

Pirofila Tonda  
Fleischpastete Ofenschale  
Plat four rond  
Plato horno redondo

| art.     | Ø cm. | h. cm. | cm. est.    | lt. | Kg. |
|----------|-------|--------|-------------|-----|-----|
| 44708S28 | 28    | 4,5    | 33x28,3x5,4 | 2,2 | 1,5 |

## PACKAGING IMBALLO



All dishes are packed with a cardboard tie that highlights the design, color and shine of the product. Protects when nested and allows for creative in-store merchandising. A tasty mood picture to inspire the final customer and a precise diagram of inner and outer dimensions, icons of use and safety and a reminder of the entire Appolia range.

Tutte le pirofile sono confezionate con una cravatta di cartone che lascia in evidenza il design, il colore e la lucentezza del prodotto. Proteggere quando impilate e consente un merchandising creativo in negozio. Riporta un'immagine ambientata per ispirare il cliente finale, un diagramma preciso delle dimensioni interne ed esterne per assistere il cliente nella scelta, icone di utilizzo e sicurezza e un promemoria dell'intera gamma Appolia.



# SERIES LIVING

TABLE TOP  
TAVOLA



A complete stainless steel line, that is able to join assortment, beauty, strenght and functionality. Quality items that can be used in order to set the most charming tables and buffets, but also in order to have a well-equipped kitchen. The easiest way to serve with charm any kind of dishes: from spaghetti to meat, fish, bread, vegetables, cheese and fruit. It is also indicated for tiny preparations such as sweets, olives and pickles. Nothing will unintentionally escape!

Una linea completa capace di coniugare assortimento, bellezza, robustezza e funzionalità, realizzata in acciaio inox. Oggetti di qualità per apparecchiare le tavole ed i buffet più raffinati, ma anche per disporre quotidianamente di una cucina super-attrezzata. Il modo più pratico per servire con eleganza e facilità ogni tipo di pietanza dagli spaghetti alla carne, pesce, pane, verdure, formaggi e frutta ma anche piccoli alimenti come dolciumi, olive e sottaceti. Niente potrà sfuggire inavvertitamente!



**Vegetables serving plier**

Forbice per verdure  
Salad-/Gemüsezange  
Pince à légumes  
Pinza verduras

| art.     | dim. cm. |
|----------|----------|
| 12550-81 | 24       |



**Serving plier**

Forbice tutto servire  
Servierzange  
Pince à servir  
Pinza servir

| art.     | dim. cm. |
|----------|----------|
| 12550-83 | 21,0     |
| 12550-84 | 26,5     |
| 12550-85 | 24,0     |



**Pie plier**

Forbice per torta  
Kuchenzange  
Pince à tarte  
Pinza pasteles

| art.     | dim. cm. |
|----------|----------|
| 12550-80 | 28       |



**Hors-d'oeuvres and pastry plier**

Forbice per antipasti e dolci  
Vorspeisen-/Pâtisseriezange  
Pince à hors-d'oeuvres et pâtisserie  
Pinza entremeses y pasteles

| art.     | dim. cm. |
|----------|----------|
| 12550-87 | 15       |
| 12550-89 | 20       |



**Pastry plier**

Forbice per dolci  
Gebäckzange  
Pince à pâtisserie  
Pinza pasteles

| art.     | dim. cm. |
|----------|----------|
| 12550-88 | 18       |



**Fruit tongs**

Molla per frutta  
Fruchtzange  
Pince à fruits  
Pinza frutas

| art.     | dim. cm. |
|----------|----------|
| 12550-50 | 23,5     |



**Spaghetti tongs**

Molla per spaghetti  
Spaghettizange  
Pince à spaghetti  
Pinza espaguetti

| art.     | dim. cm. |
|----------|----------|
| 12550-73 | 21       |
| 12550-74 | 30       |



**Toast and pastry tongs**

Molla per toast e dolci  
Toast-/Gebäckzange  
Pince à toast et tarte  
Pinza pasteles y tostadas

| art.     | dim. cm. |
|----------|----------|
| 12550-77 | 21       |
| 12550-78 | 24       |



**Multipurpose tongs**

Molla universale  
Universalzange  
Pince universelle  
Pinza universal

| art.     | dim. cm. |
|----------|----------|
| 12550-58 | 30       |



**Serving tongs**

Molla tutto servire  
Servierzange  
Pince à servir  
Pinza asados y verduras

| art.     | dim. cm. |
|----------|----------|
| 12550-68 | 21       |
| 12550-69 | 26       |
| 12550-70 | 30       |



**Bread and pastry tongs**

Molla per pane e pasticceria  
Brot-/Gebäckzange  
Pince à pain et pâtisserie  
Pinza pan y pasteles

| art.     | dim. cm. |
|----------|----------|
| 12550-62 | 18       |
| 12550-63 | 23       |
| 12550-64 | 26       |







**Snail tongs**

Molla per lumache  
Schneckenzange  
Pince à escargots  
Pinza caracoles

art. dim. cm.  
12550-60 17



**Asparagus tongs**

Molla per asparagi  
Spargelzange  
Pince à asperges  
Pinza espárragos

art. dim. cm.  
12550-66 23



**Ice tongs**

Molla per ghiaccio  
Eiszange  
Pince à glace  
Pinza hielo

art. dim. cm.  
12550-56 17,5



**Sugar tongs**

Molla per zucchero  
Zuckerzange  
Pince à sucre  
Pinza azúcar

art. dim. cm.  
12550-53 12



**Sugar tongs**

Molla per zucchero  
Zuckerzange  
Pince à sucre  
Pinza azúcar

art. dim. cm.  
12550-54 12,5



**Ice tongs**

Molla per ghiaccio  
Eiszange  
Pince à glace  
Pinza hielo

art. dim. cm.  
12550-55 18,5



**Panettone knife**

Coltello panettone  
Tortenmesser  
Couteau à gâteau  
Cuchillo tarta

art. dim. cm.  
12550-34 32



**Cake server**

Pala torta  
Tortenheber  
Pelle à gâteau  
Pala tarta

art. dim. cm.  
12550-02 30



**Serving fork**

Forchetta a servire  
Serviergabel  
Fourchette à servir  
Tenedor servir

art. dim. cm.  
12550-11 29,5  
12550-12 26,0



**Serving spoon**

Cucchiaio a servire  
Servierlöffel  
Cuiller à servir  
Cuchara servir

art. dim. cm.  
12550-13 30,0  
12550-14 25,5  
12550-22 39,0



**Serving spoon perforated**

Cucchiaio a servire forato  
Servierlöffel, perforiert  
Cuiller à servir perforée  
Cuchara servir, perforada

| art.     | dim. cm. |
|----------|----------|
| 12550-25 | 25,5     |
| 12550-26 | 30,0     |



**Ladle**

Mestolo  
Schöpfer  
Louche  
Cazo

| art.     | dim. cm. |
|----------|----------|
| 12550-01 | 25,5     |



**Sauce ladle**

Coppino salsa  
Dressingschöpfer  
Louche à sauce  
Cazillo salsas

| art.     | dim. cm. |
|----------|----------|
| 12550-20 | 16       |



**Perforated sauce ladle**

Coppino forato  
Dressingschöpfer, gelocht  
Louche à sauce percée  
Cazillo, perforado

| art.     | dim. cm. |
|----------|----------|
| 12550-21 | 16,5     |



**Spaghetti serving fork**

Forchettone spaghetti  
Spaghettivorlegegabel  
Fourchette à servir spaghetti  
Tenedor servir espagueti

| art.     | dim. cm. |
|----------|----------|
| 12550-15 | 28,5     |



**Rice ladle**

Cucchiaio risotto  
Reislöffel  
Cuiller à risotto  
Cuchara arroz

| art.     | dim. cm. |
|----------|----------|
| 12550-16 | 28       |



**Meat fork**

Forchettone  
Tranchiergabel  
Fourchette  
Tenedor

| art.     | dim. cm. |
|----------|----------|
| 12550-30 | 32       |



**Roast beef knife**

Coltello arrosto  
Tranchiermesser  
Couteau à rôtis  
Cuchillo roastbeef

| art.     | dim. cm. |
|----------|----------|
| 12550-33 | 32       |



**Salt spoon**

Cucchiaino sale  
Salzlöffel  
Cuiller à sel  
Cucharita para sal

| art.     | dim. cm. | U. Pack |
|----------|----------|---------|
| 12550-17 | 6,5      | 6       |



**Ice tea spoon**

Cucchiaio bibita  
Limonadenlöffel  
Cuillère à soda  
Cuchara refresco

| art.     | dim. cm. | U. Pack |
|----------|----------|---------|
| 12550-36 | 19,5     | 6       |



**Oyster fork**

Forchettina ostriche  
Austerngabel  
Fourchette à huîtres  
Tenedor ostras

| art.     | dim. cm. | U. Pack |
|----------|----------|---------|
| 12550-43 | 14       | 6       |





**Escargot fork**

Forchetta per lumache  
Schneckengabel  
Fourchette à escargots  
Tenedor caracoles

| art.     | dim. cm. | U. Pack |
|----------|----------|---------|
| 12550-19 | 14       | 6       |



**Ice spoon**

Cucchiaio ghiaccio  
Eislöffel  
Cuillère à glace  
Cuchara hielo

| art.     | dim. cm. |
|----------|----------|
| 12550-04 | 22       |



**Dressing spoon**

Cucchiaio salsa  
Saucenlöffel  
Cuillère à sauce  
Cuchara salsa

| art.     | dim. cm. |
|----------|----------|
| 12550-06 | 22       |



**Monoportion spoon**

Cucchiaio monoporzion  
Monoporzion-Löffel  
Cuillère monoportion  
Cuchara monoporción

| art.     | dim. cm. | U. Pack |
|----------|----------|---------|
| 12550-03 | 9,5      | 6       |
| 12550-07 | 12,0     | 6       |



**Monoportion fork**

Forchetta monoporzion  
Monoporzion-Gabel  
Fourchette monoportion  
Tenedor monoporción

| art.     | dim. cm. | U. Pack |
|----------|----------|---------|
| 12550-05 | 9,5      | 6       |



**Monoportion fork**

Forchetta monoporzion  
Monoporzion-Gabel  
Fourchette monoportion  
Tenedor monoporción

| art.     | dim. cm. | U. Pack |
|----------|----------|---------|
| 12550-09 | 12       | 6       |





# DISPLAY & PRESENTATION

BUFFET







**Serving stand, chrome plated**  
Supporto cromato  
Serviergestell, hartverchromt  
Présentoir, acier chromé  
Soporte platos pastre, acero cromado  
.....  
art. dim. cm.  
44840-01 29x17x41

**For 3 plates cm. 18x18 or 21x21.**  
Per 3 piatti cm. 18x18 oppure 21x21.



**Serving stand, chrome plated**  
Supporto cromato  
Serviergestell, hartverchromt  
Présentoir, acier chromé  
Soporte platos pastre, acero cromado  
.....  
art. dim. cm.  
44840-02 33x21x44

**For 3 plates cm. 21x21 or 26,5x26,5.**  
Per 3 piatti cm. 21x21 oppure 26,5x26,5.



**Serving stand, chrome plated**  
Supporto cromato  
Serviergestell, hartverchromt  
Présentoir, acier chromé  
Soporte platos pastre, acero cromado  
.....  
art. dim. cm.  
44840-03 37x21x44

**For 3 plates cm. 30x21. – Per 3 piatti cm. 30x21.**



**Serving stand, chrome plated**  
Supporto cromato  
Serviergestell, hartverchromt  
Présentoir, acier chromé  
Soporte platos pastre, acero cromado  
.....  
art. dim. cm.  
44840-04 63x27x44,5

**For 2 plates cm. 53x32,5 or 4 plates cm. 53x16,2.**  
Per 2 piatti cm. 53x32,5 oppure 4 piatti cm. 53x16,2.



**Serving stand, chrome plated**  
Supporto cromato  
Serviergestell, hartverchromt  
Présentoir, acier chromé  
Soporte platos pastre, acero cromado  
.....  
art. dim. cm.  
44840-05 37,5x37,5x50

**For plates in 3 different sizes: cm. 21x21-26,5x26,5-37x37. – Per piatti di 3 diverse misure: cm. 21x21-26,5x26,5-37x37.**



**Serving stand, chrome plated**  
Supporto cromato  
Serviergestell, hartverchromt  
Présentoir, acier chromé  
Soporte, acero cromado  
.....  
art. Ø cm. h. cm.  
44840-27 22 59

**Suitable glasses/Vasetti idonei: 41589C08, 41589C16, 41589-08, 41589-14, 41589-16.**



**Serving stand, chrome plated**  
Supporto cromato  
Serviergestell, hartverchromt  
Présentoir, acier chromé  
Soporte, acero cromado  
.....  
art. Ø cm. h. cm.  
44840-28 22 33

**Suitable glasses/Vasetti idonei: 41589C08, 41589C16, 41589-08, 41589-14, 41589-16.**



**Square bowl**  
Ciotola quadra  
Schüssel, quadratisch  
Bol carré  
Bol cuadrado  
.....  
art. dim. cm.  
44847B09 9x9x4  
44847B13 12,5x12,5x6,5  
44847B20 19x19x9

**MF**



MF

**Square bowl**

Ciotola quadra  
Schüssel, quadratisch  
Bol carré  
Bol cuadrado

| art.     | dim. cm.      |
|----------|---------------|
| 44847-09 | 9x9x4         |
| 44847-13 | 12,5x12,5x6,5 |
| 44847-20 | 19x19x9       |



MF

**Round bowl**

Ciotola tonda  
Schüssel, rund  
Bol ronde  
Bol redondo

| art.     | Ø cm. | h. cm. |
|----------|-------|--------|
| 44846B05 | 5,5   | 4,0    |
| 44846B09 | 9,0   | 4,5    |
| 44846B13 | 13,0  | 6,5    |
| 44846B15 | 15,0  | 7,5    |



MF

**Round bowl**

Ciotola tonda  
Schüssel, rund  
Bol ronde  
Bol redondo

| art.     | Ø cm. | h. cm. |
|----------|-------|--------|
| 44846-05 | 5,5   | 4,0    |
| 44846-09 | 9,0   | 4,5    |
| 44846-13 | 13,0  | 6,5    |
| 44846-15 | 15,0  | 7,5    |



MF

**Party plate**

Piattino fingerfood  
Fingerfood-Teller  
Petit assiette  
Platillo

| art.     | dim. cm.    | col. |
|----------|-------------|------|
| 44844-01 | 9,5x9,5x1,5 | ○    |
| 44844B01 | 9,5x9,5x1,5 | ●    |



GN

MF

**Tray**

Vassoio  
Tablett  
Plateau  
Bandeja

| art.     | dim. cm.    | GN  |
|----------|-------------|-----|
| 44844-11 | 53x32,5x2,5 | 1/1 |



MF

**Tray, square**

Vassoio quadro  
Tablett, quadratisch  
Plateau carré  
Bandeja, cuadrada

| art.     | dim. cm.  |
|----------|-----------|
| 44841-18 | 18x18     |
| 44841-21 | 21x21     |
| 44841-26 | 26,5x26,5 |
| 44841-37 | 37x37     |
| 44841-51 | 51x51     |



MF

**Tray, square**

Vassoio quadro  
Tablett, quadratisch  
Plateau carré  
Bandeja, cuadrada

| art.     | dim. cm. |
|----------|----------|
| 44841B51 | 51x51    |





MF

**Sushi tray**

Vassoio sushi  
Sushiplatte  
Plateau sushi  
Bandeja sushi

| art.     | dim. cm. |
|----------|----------|
| 44842B31 | 31x10,5  |
| 44842B53 | 53x18    |



MF

**Sushi tray**

Vassoio sushi  
Sushiplatte  
Plateau sushi  
Bandeja sushi

| art.     | dim. cm. |
|----------|----------|
| 44842-31 | 31x10,5  |
| 44842-35 | 35,5x18  |
| 44842-30 | 30x21    |
| 44842-53 | 53x18    |



GN

MF

**Tray**

Vassoio  
Tablett  
Plateau  
Bandeja

| art.     | dim. cm.  | GN  |
|----------|-----------|-----|
| 44843-11 | 53x32,5   | 1/1 |
| 44843-12 | 32,5x26,5 | 1/2 |
| 44843-24 | 53x16,2   | 2/4 |
| 44843-13 | 32,5x17,5 | 1/3 |
| 44843-14 | 26,5x16,2 | 1/4 |



GN

MF

**Tray**

Vassoio  
Tablett  
Plateau  
Bandeja

| art.     | dim. cm.  | GN  |
|----------|-----------|-----|
| 44843B11 | 53x32,5   | 1/1 |
| 44843B12 | 32,5x26,5 | 1/2 |
| 44843B24 | 53x16,2   | 2/4 |
| 44843B13 | 32,5x17,5 | 1/3 |
| 44843B14 | 26,5x16,2 | 1/4 |



MF

**Round dish**

Piatto tondo  
Platte, rund  
Plat rond  
Bandeja redonda

| art.     | Ø cm. |
|----------|-------|
| 44845-51 | 51    |
| 44845-30 | 30    |
| 44845-41 | 41    |



MF

**Bowl**

Ciotola  
Schale  
Bol  
Bol

| art.     | Ø cm. | h. cm. | ml. |
|----------|-------|--------|-----|
| 44466-07 | 7     | 6      | 50  |



MF

**Bowl**

Ciotola  
Schale  
Bol  
Bol

| art.     | dim. cm.  | lt.  |
|----------|-----------|------|
| 44466-11 | 7,5x7x4,5 | 0,05 |



MF

**Bowl**

Ciotola  
Schale  
Bol  
Bol

| art.     | dim. cm.   | lt.  |
|----------|------------|------|
| 44466-12 | 11,5x7,5x3 | 0,06 |



MF

**Bowl**

Ciotola  
Schale  
Bol  
Bol

| art.     | dim. cm.   | lt.  |
|----------|------------|------|
| 44466-13 | 11,5x6x5,5 | 0,04 |



MF

**Bowl**

Ciotola  
Schale  
Bol  
Bol

| art.     | dim. cm. | lt.  |
|----------|----------|------|
| 44466-14 | 8,5x7x6  | 0,07 |



MF

**Bowl**

Ciotola  
Schale  
Bol  
Bol

| art.     | dim. cm. | lt. |
|----------|----------|-----|
| 44466-15 | 8x8x4    | 0,1 |



MF

**Bowl**

Ciotola  
Schale  
Bol  
Bol

| art.     | dim. cm. | lt. |
|----------|----------|-----|
| 44466-16 | 35x4,5x3 | 0,2 |



MF

**Party spoon**

Cucchiaio finger-food  
Finger-food-Löffel  
Cuiller  
Cucharita

| art.     | dim. cm. | col. |
|----------|----------|------|
| 44850-11 | 11x4,3   | ○    |
| 44850B11 | 10x4,5   | ●    |



MF

**Party spoon**

Cucchiaio finger-food  
Finger-food-Löffel  
Cuiller  
Cucharita

| art.     | dim. cm. | col. |
|----------|----------|------|
| 44850-13 | 13,5x4,5 | ○    |
| 44850B13 | 13,5x4,5 | ●    |



MF

**Party spoon**

Cucchiaio finger-food  
Finger-food-Löffel  
Cuiller  
Cucharita

| art.     | dim. cm. | col. |
|----------|----------|------|
| 44850-12 | 10x4,5x1 | ○    |
| 44850B12 | 10x4,5x1 | ●    |
| 44850G12 | 10x4,5x1 | ●    |



MF

**Party spoon**

Cucchiaio finger-food  
Finger-food-Löffel  
Cuiller  
Cucharita

| art.     | dim. cm. |
|----------|----------|
| 44851-01 | 14,5x4,5 |



MF

**Party spoon**

Cucchiaio finger-food  
Finger-food-Löffel  
Cuiller  
Cucharita

| art.     | dim. cm. | col. |
|----------|----------|------|
| 44851-02 | 14,5x4,5 | ○    |
| 44851-03 | 14,5x4,5 | ●    |



MF

**Spoon, set 6 pcs**

Cucchiaio, set 6 pz  
Löffel, 6er Set  
Cuiller, set 6 pcs  
Cuchara, set 6 pz

| art.     | dim. cm. | col. |
|----------|----------|------|
| 44850-00 | 6x23     | ○    |



PVD

SS

**Party spoon**

Cucchiaio gourmet  
Gourmet-Löffel  
Cuiller gourmet  
Cuchara gourmet

| art.     | l. cm. | col. |
|----------|--------|------|
| 42988-99 | 13,5   | ●    |
| 42988C99 | 12,0   | ●    |
| 42988G99 | 12,0   | ●    |



MF

**Bowl oval**

Pirofila ovale  
Schale, oval  
Plat oval  
Fuente ovale

| art.     | dim. cm.  | lt. |
|----------|-----------|-----|
| 44849-27 | 27x17x4   | 0,8 |
| 44849-34 | 34x21x4,5 | 1,3 |
| 44849-47 | 47x29x5   | 3,2 |







MF

**Bowl**  
Insalatiera  
Schüssel  
Saladier  
Bol

| art.     | Ø cm. | h. cm. |
|----------|-------|--------|
| 44836-30 | 30    | 10     |



MF

**Bowl**  
Insalatiera  
Schüssel  
Saladier  
Bol

| art.     | dim. cm.   |
|----------|------------|
| 44834-03 | 40x18,5x10 |



MF

**Plate**  
Piatto  
Platte  
Plaque  
Plato

| art.     | dim. cm.  |
|----------|-----------|
| 44835-36 | 36x16x3   |
| 44835-45 | 45x24x3   |
| 44835-53 | 53x29x3,5 |



MF

**Plate**  
Piatto  
Platte  
Plaque  
Plato

| art.     | dim. cm.   |
|----------|------------|
| 44834-00 | 34,5x8x2,5 |



MF

**Plate**  
Piatto  
Platte  
Plaque  
Plato

| art.     | dim. cm.    |
|----------|-------------|
| 44834-01 | 40x18,5x3,5 |
| 44834-02 | 52x25x4     |



MF

**Bowl**  
Insalatiera  
Schüssel  
Saladier  
Bol

| art.     | dim. cm.   |
|----------|------------|
| 44834G03 | 40x18,5x10 |



MF

**Bowl**  
Insalatiera  
Schüssel  
Saladier  
Bol

| art.     | Ø cm. | h. cm. |
|----------|-------|--------|
| 44836G30 | 30    | 10     |



MF

**Plate**  
Piatto  
Platte  
Plaque  
Plato

| art.     | dim. cm.  |
|----------|-----------|
| 44835G36 | 36x16x3   |
| 44835G45 | 45x24x3   |
| 44835G53 | 53x29x3,5 |



MF

**Plate**  
Piatto  
Platte  
Plaque  
Plato

| art.     | dim. cm.   |
|----------|------------|
| 44834G00 | 34,5x8x2,5 |



MF

**Plate**  
Piatto  
Platte  
Plaque  
Plato

| art.     | dim. cm.    |
|----------|-------------|
| 44834G01 | 40x18,5x3,5 |
| 44834G02 | 52x25x4     |

TAO MELAMINE



Mirror shiny inside, outside matt.

Interno lucido, esterno satinato.



**Bowl**  
Ciotola  
Schale  
Bol  
Bol

| art.     | dim. cm.     | lt. | col. |
|----------|--------------|-----|------|
| 44449-32 | 32,5x17,5x10 | 1,8 | ○    |
| 44449B32 | 32,5x17,5x10 | 1,8 | ●    |



**Bowl**  
Ciotola  
Schale  
Bol  
Bol

| art.     | dim. cm.     | lt. | col. |
|----------|--------------|-----|------|
| 44449-30 | 30,5x30,5x10 | 3,3 | ○    |
| 44449B30 | 30,5x30,5x10 | 3,3 | ●    |



**Bowl**  
Ciotola  
Schale  
Bol  
Bol

| art.     | dim. cm.      | col. |
|----------|---------------|------|
| 44446-10 | 10,5x10x6,5   | ○    |
| 44446-14 | 13,5x12,5x8,5 | ○    |
| 44446-18 | 17x16x10,5    | ○    |



**Bowl**  
Ciotola  
Schale  
Bol  
Bol

| art.     | dim. cm.      | col. |
|----------|---------------|------|
| 44446B10 | 10,5x10x6,5   | ●    |
| 44446B14 | 13,5x12,5x8,5 | ●    |
| 44446B18 | 17x16x10,5    | ●    |



**Tray**  
Vassoio  
Tablett  
Plateau  
Bandeja

| art.     | dim. cm.  | col. |
|----------|-----------|------|
| 44842-31 | 31x10,5x2 | ○    |
| 44842B31 | 31x10,5x2 | ●    |







Withstands temperatures from -20°C to +70°C.

Termoresistenti da -20°C a +70°C.



**Serving board**

Tagliere  
Servier-Brett  
Planche

**Tabla**

| art.     | Ø cm. | h. cm. |
|----------|-------|--------|
| 44470-30 | 30    | 1      |
| 44470-40 | 40    | 1      |



**Platter**

Plancia  
Tablett  
Plateau  
Bandeja

| art.     | dim. cm.    | GN  |
|----------|-------------|-----|
| 44470-11 | 53,0x32,5x1 | 1/1 |
| 44470-24 | 53,0x16,2x1 | 2/4 |
| 44470-12 | 32,5x26,5x1 | 1/2 |
| 44470-13 | 32,5x17,5x1 | 1/3 |
| 44470-14 | 26,5x16,5x1 | 1/4 |



**Platter**

Plancia  
Tablett  
Plateau  
Bandeja

| art.     | dim. cm. |
|----------|----------|
| 44470-73 | 20x10x2  |
| 44470-74 | 30x10x2  |
| 44470-75 | 30x15x2  |



**Bowl**

Ciotola  
Schüssel  
Bol  
Bol Ensalada

| art.     | dim. cm. | lt. |
|----------|----------|-----|
| 44470-03 | 19x19x9  | 1,5 |
| 44470-04 | 25x25x12 | 3,8 |



NEW

**Cake/cheese tray**  
Piatto torta/formaggi  
Kuchen/Käseplatte  
Plat gâteau/fromage  
Bandeja pasteles/queso

| art.     | Ø cm. | h. cm. |
|----------|-------|--------|
| 44470-22 | 21,5  | 2,5    |
| 44470-31 | 30,5  | 3,5    |
| 44470-38 | 37,5  | 4,0    |

**With non-slip feet. With carved edge fixing the cover.** – Con piedini antiscivolo. Con bordo fissa-coperchio.



NEW

PC

**Dome cover**  
Campana  
Haube  
Cloche  
Campana

| art.     | dim. cm. | fits/per |
|----------|----------|----------|
| 41414-21 | 21x17    | 44470-22 |
| 41414-31 | 30x22    | 44470-31 |
| 41414-36 | 36x27    | 44470-38 |

GLOBAL MELAMINE



**Bowl**  
Ciotola  
Schale  
Bol  
Bol

| art.     | dim. cm.     |
|----------|--------------|
| 44889-32 | 32,5x32,5x12 |
| 44889-35 | 35x35x12,5   |
| 44889-40 | 40x40x14     |



**Bowl**  
Ciotola  
Schale  
Bol  
Bol

| art.     | Ø cm. | h. cm. |
|----------|-------|--------|
| 44888-32 | 32    | 16,5   |
| 44888-35 | 35    | 17,0   |
| 44888-40 | 40    | 17,5   |



**Bowl**  
Ciotola  
Schale  
Bol  
Bol

| art.     | dim. cm.     | lt. |
|----------|--------------|-----|
| 44882-35 | 35,5x31,5x14 | 2,5 |
| 44882-46 | 46x40x18,5   | 5,5 |





**BUFFET**



**Plate**  
Piatto  
Teller  
Assiette  
Plato

| art.     | Ø cm. | h. cm. |
|----------|-------|--------|
| 44477-24 | 11,0  | 2      |
| 44477-25 | 16,0  | 2      |
| 44477-26 | 19,5  | 2      |
| 44477-27 | 24,0  | 2      |
| 44477-28 | 28,0  | 2      |



**Bowl**  
Ciotola  
Schüssel  
Bol  
Bol

| art.     | Ø cm. | h. cm. | lt.  |
|----------|-------|--------|------|
| 44477-40 | 7,5   | 3,0    | 0,04 |
| 44477-41 | 7,5   | 6,5    | 0,13 |
| 44477-44 | 23,0  | 3,0    | 0,40 |

**Picture/Foto: 44477-24 + 44477-41.**



**Bowl**  
Ciotola  
Schüssel  
Bol  
Bol

| art.     | dim. cm.      | lt.  |
|----------|---------------|------|
| 44477-52 | 7,5x7,5x3     | 0,05 |
| 44477-53 | 7,5x7,5x6,5   | 0,16 |
| 44477-54 | 15,5x15,5x3   | 0,19 |
| 44477-55 | 15,5x15,5x6,5 | 0,85 |



**Bowl**  
Ciotola  
Schüssel  
Bol  
Bol

| art.     | dim. cm.     | lt.  |
|----------|--------------|------|
| 44477-64 | 15,5x7,5x3   | 0,10 |
| 44477-65 | 15,5x7,5x6,5 | 0,40 |
| 44477-66 | 15,5x9,5x3   | 0,15 |
| 44477-67 | 15,5x9,5x6,5 | 0,50 |
| 44477-68 | 25x15,5x3    | 0,30 |
| 44477-69 | 25x15,5x6,5  | 1,40 |



**GN**

**Tray**  
Vassoio  
Tablett  
Plateau  
Bandeja

| art.     | dim. cm.    | GN  |
|----------|-------------|-----|
| 44477-76 | 53x32,5x3   | 1/1 |
| 44477-77 | 32,5x26,5x3 | 1/2 |
| 44477-78 | 32,5x17,6x3 | 1/3 |
| 44477-79 | 26,5x16,2x3 | 1/4 |
| 44477-80 | 35,4x32,5x3 | 2/3 |
| 44477-81 | 53x16,2x3   | 2/4 |

**Picture/Foto: 44477-52, -53, -66, -77.**



**Bowl**  
Ciotola  
Schüssel  
Bol  
Bol

| art.     | Ø cm. | h. cm. | lt. |
|----------|-------|--------|-----|
| 41446-18 | 18    | 9,5    | 1,0 |
| 41446-23 | 23    | 12,5   | 2,2 |

**Concrete. – Cemento.**



## BUFFET DISPLAY & PRESENTATION



### Bowl

Ciotola  
Schüssel  
Bol  
Bol

| art.     | Ø cm. | h. cm. | lt. |
|----------|-------|--------|-----|
| 41445-22 | 22,0  | 10,5   | 1,1 |
| 41445-26 | 26,0  | 13,0   | 1,7 |
| 41445-30 | 29,5  | 14,5   | 2,5 |

**Concrete. – Cemento.**



### Stand chromed

Alzata cromata  
Ständer, verchromt  
Support chromé  
Soporte cromado

| art.     | dim. cm.            |
|----------|---------------------|
| 44840-50 | 53x32,5-53x16,5     |
| 44840-51 | 32,5x26,5-26,5x16,2 |
| 44840-52 | 32,5x17,5-35,4x32,5 |



### Stand

Alzata  
Ständer  
Support  
Soporte

| art.     | dim. cm.            |
|----------|---------------------|
| 44840-55 | 53x32,5-53x16,5     |
| 44840-56 | 32,5x26,5-26,5x16,2 |
| 44840-57 | 32,5x17,5-35,4x32,5 |

**Black coating. – Rivestimento nero.**



### Cutting board

Tagliere  
Schneidebrett  
Planche à découper  
Table de corte

| art.     | dim. cm.      |
|----------|---------------|
| 44840-54 | 35,4x32,5x3,5 |

**Walnut/Noce. Fits stands/Per supporti 44840-52 & 44840-57.**



### Drawer with black handle

Cassetto con pomolo nero  
Schublade, schwarzer Griff  
Tiroir poignée noire  
Cajón con pomo negro

| art.     | dim. cm.   |
|----------|------------|
| 44840-58 | 34x32x17,5 |

**Fits stand 44840-57. – Per supporto 44840-57.**



### Drawer with chrome handle

Cassetto con pomolo cromato  
Schublade, Chromgriff  
Tiroir poignée chromée  
Cajón con pomo cromado

| art.     | dim. cm.   |
|----------|------------|
| 44840-53 | 34x32x17,5 |

**Fits stand 44840-52. – Per supporto 44840-52.**



### Stand chromed

Alzata cromata  
Ständer, verchromt  
Support chromé  
Soporte cromado

| art.     | Ø cm. | h. cm. |
|----------|-------|--------|
| 44478-77 | 38,0  | 16,5   |
| 44478-79 | 48,5  | 16,5   |



### Stand chromed

Alzata cromata  
Ständer, verchromt  
Support chromé  
Soporte cromado

| art.     | Ø cm. | h. cm. |
|----------|-------|--------|
| 44478-78 | 38,0  | 27     |
| 44478-80 | 48,5  | 27     |



**BUFFET**



**Tray**  
Vassoio  
Tablett  
Plateau  
Bandeja

| art.     | Ø cm. | h. cm. |
|----------|-------|--------|
| 44478-70 | 30,0  | 3      |
| 44478-71 | 38,0  | 3      |
| 44478-72 | 48,5  | 3      |



**Tray**  
Vassoio  
Tablett  
Plateau  
Bandeja

| art.     | Ø cm. | h. cm. |
|----------|-------|--------|
| 44478-73 | 38,0  | 2,5    |
| 44478-74 | 48,5  | 2,5    |



**Intermediate tray**  
Vassoio intermedio  
Zwischenplatte  
Plateau intermédiaire  
Bandeja intermedia

| art.     | Ø cm. | h. cm. |
|----------|-------|--------|
| 44478-75 | 38,0  | 2,5    |
| 44478-76 | 48,5  | 2,5    |



**Stand**  
Alzata  
Ständer  
Support  
Soporte

| art.     | h. cm. |
|----------|--------|
| 44840-30 | 8      |
| 44840-31 | 12     |
| 44840-32 | 18     |

**Black anti-slide coating.**  
Rivestimento antiscivolo nero.



**Stand**  
Alzata  
Ständer  
Support  
Soporte

| art.     | Ø cm.   | h. cm. |
|----------|---------|--------|
| 44840-40 | 15,5-18 | 8      |
| 44840-41 | 15,5-18 | 10     |
| 44840-42 | 15,5-18 | 18     |

**Black anti-slide coating.**  
Rivestimento antiscivolo nero.





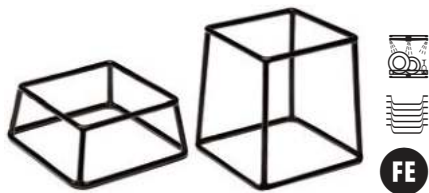

FE

**Stand**  
Alzata  
Ständer  
Support  
Soporte

| art.     | dim. cm. |
|----------|----------|
| 44840-08 | 18x18x8  |
| 44840-10 | 18x18x10 |
| 44840-18 | 18x18x18 |

**Black anti-slide coating.**  
Rivestimento antiscivolo nero.



FE

**Basket**  
Cesto  
Korb  
Panier  
Cesta

| art.     | Ø cm.   | h. cm. |
|----------|---------|--------|
| 44476-20 | 21-16,5 | 21     |



SS

**Stand/basket**  
Alzata/cesto  
Ständer/Korb  
Support/panier  
Soporte/cesta

| art.     | Ø cm. | h. cm. |
|----------|-------|--------|
| 44476-26 | 21    | 10,5   |
| 44476-28 | 21    | 20,0   |



SS

**Stand/basket**  
Alzata/cesto  
Ständer/Korb  
Support/panier  
Soporte/cesta

| art.     | Ø cm. | h. cm. | col. |
|----------|-------|--------|------|
| 44476-27 | 21    | 10,5   | ●    |
| 44476-29 | 21    | 20,0   | ●    |



FE

**Stand/basket**  
Alzata/cesto  
Ständer/Korb  
Support/panier  
Soporte/cesta

| art.     | Ø cm.  | h. cm. | col. |
|----------|--------|--------|------|
| 44476-51 | 10,5-8 | 8      | ●    |



FE

**Stand/basket**  
Alzata/cesto  
Ständer/Korb  
Support/panier  
Soporte/cesta

| art.     | Ø cm.  | h. cm. | col. |
|----------|--------|--------|------|
| 44476-52 | 10,5-8 | 8      | ●    |



FE

**Stand/basket**  
Alzata/cesto  
Ständer/Korb  
Support/panier  
Soporte/cesta

| art.     | Ø cm.  | h. cm. | col. |
|----------|--------|--------|------|
| 44476-53 | 10,5-8 | 8      | ●    |



FE

**Stand/basket chromed**  
Alzata/cesto cromato  
Ständer/Korb, verchromt  
Support/panier, chromé  
Soporte/cesta cromado

| art.     | Ø cm. | h. cm. |
|----------|-------|--------|
| 44476-30 | 15    | 10,5   |
| 44476-31 | 21    | 20,0   |



FE

**Stand/basket**  
Alzata/cesto  
Ständer/Korb  
Support/panier  
Soporte/cesta

| art.     | Ø cm. | h. cm. | col. |
|----------|-------|--------|------|
| 44476-32 | 15    | 10,5   | ●    |
| 44476-33 | 21    | 20,0   | ●    |



PMMA

**Buffet display, 3 pcs set**  
Display per buffet, set 3 pz  
Buffetgestell, 3er Set  
Etagère à buffet, set 3 pcs  
Expositor para buffet, set 3 pz

| art.     | dim. cm. |
|----------|----------|
| 41919-03 | 40x18x4  |
| 41919-03 | 40x20x8  |
| 41919-03 | 40x22x12 |





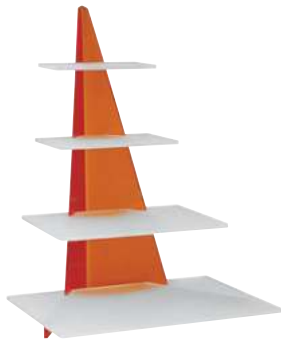

**Buffet display**

Display per buffet  
Büffetgestell  
Etagère à buffet  
Expositor para buffet

art. dim. cm.  
41870-01 54x47x63

**Shelves/Ripiani: 47x34 - 37x25 - 27x17 - 23x13 cm.**



**Buffet display**

Display per buffet  
Büffetgestell  
Etagère à buffet  
Expositor para buffet

art. Ø cm. h. cm.  
41870-03 28 29

**Shelves/Ripiani: 38x30x21 - 38x30x13 - 38x30x5 cm.**

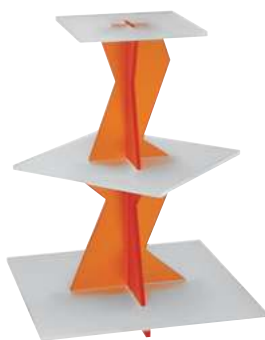

**Buffet display**

Display per buffet  
Büffetgestell  
Etagère à buffet  
Expositor para buffet

art. dim. cm.  
41870-02 40x40x53

**Shelves/Ripiani: 40x40 - 30x30 - 22x22 - 27x17 - 23x13 cm.**



**Buffet display**

Display per buffet  
Büffetgestell  
Etagère à buffet  
Expositor para buffet

art. dim. cm.  
41870-04 40x27x29

**Shelves/Ripiani: 40x27x21 - 40x27x13 - 40x27x5 cm.**





SS

**Fruit stand, 3 tiers**

Alzata frutta, 3 piani  
Obstständer, 3-stöckig  
Etagère à fruits, 3 étages  
Frutero 3 pisos

| art.     | Ø cm.    | h. cm. |
|----------|----------|--------|
| 42940-03 | 32-38-48 | 50     |



**Wedding cake stand, aluminum**

Alzata per torte, alluminio  
Hochzeitstortenständer, Aluminium  
Support pour tourte de mariage, alu  
Pedestal para tartas, aluminio

| art.     | Ø cm.          |
|----------|----------------|
| 47100-03 | 20-26-32       |
| 47100-04 | 20-26-32-40    |
| 47100-05 | 20-26-32-40-45 |

**Distance between tiers 16,5 cm.**  
Distanziali h. 16,5 cm.



**Wedding cake stand, aluminum**

Alzata per torte, alluminio  
Hochzeitstortenständer, Aluminium  
Support pour tourte de mariage, alu  
Pedestal para tartas, aluminio

| art.     | Ø cm.                   |
|----------|-------------------------|
| 47100-06 | 20-26-32-40-45-50       |
| 47100-07 | 16-20-26-32-40-45-50    |
| 47100-08 | 16-20-26-32-40-45-50-55 |

**Distance between tiers 16,5 cm.**  
Distanziali h. 16,5 cm.



SS

**Lightning column**

Colonna luminosa  
Lichtsäule  
Socle lumineux  
Columna luminosa

| art.     | Ø cm. | h. cm. |
|----------|-------|--------|
| 42979-00 | 30    | 21     |

**Stainless steel base plate ø30 cm., PMMA column, LED-light box and remote control.**  
Base inox ø cm 30, colonna PMMA, scatola luci-LED con telecomando.



SS

**Oyster plate**

Piatto frutti di mare  
Austernplatte  
Plat à huîtres  
Fuente de mariscos

| art.     | Ø cm. | h. cm. |
|----------|-------|--------|
| 42979-36 | 36    | 4,5    |

**The plate has a centering element which keeps it anchored to the column.**



SS

**Oyster plate**

Piatto frutti di mare  
Austernplatte  
Plat à huîtres  
Fuente de mariscos

| art.     | Ø cm. | h. cm. |
|----------|-------|--------|
| 42979-45 | 45    | 5,5    |

**Sotto il piatto è fissato un elemento di centraggio che lo mantiene ancorato alla colonna luminosa.**



SS

**Chocolate fountain**

Fontana cioccolato  
Schokoladenbrunnen  
Fontaine à chocolat  
Fuente para chocolate

| art.     | Ø cm. | h. cm. | lt. | W   |
|----------|-------|--------|-----|-----|
| 42982-08 | 38    | 80     | 3,5 | 370 |

**230V-50Hz-Amps 1,6A. Minimum quantity of chocolate necessary for operation is about 3.5 kg, the maximum is 8 kg. –** Quantità minima di cioccolato richiesta per funzionare è di circa 3,5 kg e può contenerne fino a 8 kg.



SS

**Cocktail fountain**

Fontana cocktails  
Cocktails-Laufbrunnen  
Fontaine à cocktails  
Fuente cocktail

| art.     | Ø cm. | h. cm. | lt. |
|----------|-------|--------|-----|
| 42981-73 | 42    | 56     | 15  |

**10W 220V. NOT recommend for use with fizzy drinks or champagne. –** Prodotto NON consigliato per liquidi gasati o champagne.





**Champagne Waterfall**

Cascata champagne  
Sekt Wasserfall  
Cascade à champagne  
Cascada champán

| art.     | Ø cm. | h. cm. |
|----------|-------|--------|
| 42980-01 | 45    | 64     |

**LED lighting multicolor cycle. For 42 champagne cups.** – Illuminazione led a ciclo multicolore. Per 42 coppe champagne.



**Champagne Waterfall**

Cascata champagne  
Sekt Wasserfall  
Cascade à champagne  
Cascada champán

| art.     | Ø cm. | h. cm. |
|----------|-------|--------|
| 42980-02 | 45    | 107    |

**LED lighting multicolor cycle. For 73 champagne cups.** – Illuminazione led a ciclo multicolore. Per 73 coppe champagne.



**Punch bowl**

Coppa punch  
Punchbowle  
Rafraîchisseur  
Cubitera para champán

| art.     | Ø cm. | lt. |
|----------|-------|-----|
| 41541-44 | 44    | 15  |

**Stainless steel bottom ring.** – Piede inox.



**Punch bowl**

Coppa punch  
Punchbowle  
Rafraîchisseur  
Cubitera para champán

| art.     | Ø cm. | lt.  |
|----------|-------|------|
| 11956-37 | 36    | 9,5  |
| 11956-42 | 42    | 15,0 |



**Big party tub**

Secchio portabottiglie  
Flaschenkühler-Bowle  
Rafraîchisseur à bouteilles  
Cubitera enfriador de botellas

| art.     | dim. cm. |
|----------|----------|
| 44946-04 | 40x28x23 |



**Big party tub**

Secchio portabottiglie  
Flaschenkühler-Bowle  
Rafraîchisseur à bouteilles  
Cubitera enfriador de botellas

| art.     | dim. cm. |
|----------|----------|
| 44946B05 | 35x35x20 |





ACRYLIC MIRRORS  
SPECCHI ACRILICI PMMA



**Mirror, square**

Specchio quadrato  
Spiegel, quadratisch  
Miroir carré  
Espejo cuadrado

| art.     | dim. cm. |
|----------|----------|
| 41885-30 | 30x30    |
| 41885-40 | 40x40    |
| 41885-45 | 45x45    |
| 41885-50 | 50x50    |
| 41885-60 | 60x60    |



**Mirror, oval**

Specchio ovale  
Spiegel, oval  
Miroir ovale  
Espejo oval

| art.     | dim. cm. |
|----------|----------|
| 41877-45 | 45x30    |
| 41877-61 | 61x45,5  |
| 41877-81 | 81x61    |
| 41877-99 | 100x70   |



**Mirror, rectangular**

Specchio rettangolare  
Spiegel, rechteckig  
Miroir rectangulaire  
Espejo rectangular

| art.     | dim. cm. |
|----------|----------|
| 41878-45 | 45x30    |
| 41878-61 | 61x46    |
| 41878-81 | 81x58,5  |
| 41878-99 | 100x70   |



**Mirror, octagon**

Specchio ottagonale  
Spiegel, achteckig  
Miroir octogonal  
Espejo octogonal

| art.     | Ø cm. |
|----------|-------|
| 41879-30 | 30    |
| 41879-40 | 40    |
| 41879-50 | 50    |
| 41879-61 | 61    |



**Mirror, hexagon**

Specchio esagono  
Spiegel, Sechseck  
Miroir hexagon  
Espejo hexágono

| art.     | Ø cm. |
|----------|-------|
| 41880-38 | 38    |
| 41880-61 | 61    |



**Mirror, comma**

Specchio virgola  
Spiegel, Komma  
Miroir virgule  
Espejo vírgula

| art.     | Ø cm. |
|----------|-------|
| 41875-40 | 40,6  |
| 41875-61 | 61,0  |



**Mirror, segment**

Specchio spicchio  
Spiegel, Segment  
Miroir quartier  
Espejo segmento

| art.     | Ø cm. |
|----------|-------|
| 41881-30 | 30,5  |
| 41881-40 | 40,5  |



**Mirror, circle**

Specchio cerchio  
Spiegel, Kreis  
Miroir cercle  
Espejo aro

| art.     | Ø cm. |
|----------|-------|
| 41876-30 | 30,5  |
| 41876-38 | 38,0  |
| 41876-45 | 45,0  |
| 41876-58 | 58,0  |



**Mirror, cube**

Specchio cubo  
Spiegel, Würfel  
Miroir cube  
Espejo cubo

| art.     | dim. cm. |
|----------|----------|
| 41882-15 | 15x15x15 |
| 41882-20 | 20x20x20 |
| 41882-25 | 25x25x25 |
| 41882-30 | 30x30x30 |







**W**  
**FE**

**Set 2 lanterns**

Set 2 lanternne  
Set 2 laternen  
Set 2 lanternes  
Set 2 linternas

| art.     | dim. cm.             |
|----------|----------------------|
| 42440-30 | 22x20x52<br>30x26x71 |



**W**  
**FE**

**Set 2 lanterns**

Set 2 lanternne  
Set 2 laternen  
Set 2 lanternes  
Set 2 linternas

| art.     | dim. cm.             |
|----------|----------------------|
| 42441-25 | 17x17x44<br>25x25x62 |



**W**  
**FE**

**Set 2 lanterns**

Set 2 lanternne  
Set 2 laternen  
Set 2 lanternes  
Set 2 linternas

| art.     | dim. cm.             |
|----------|----------------------|
| 42442-24 | 17x17x45<br>24x24x67 |



**Set 3 candles**

Set 3 candele  
Kunstkerzen, 3er Set  
Set 3 bougies  
Set 3 velas

| art.     | Ø cm. | h. cm. |
|----------|-------|--------|
| 42445-03 | 9     | 12,5   |
|          | 9     | 18     |
|          | 9     | 23     |

**Resin. Timer function 5 hours ON/19 OFF. Powered by 2D alkaline batteries (not incl.). Working time >800 hours. Flameless moving wick.** – Resina. Funzione timer 5 ore ON/19 OFF. 2 batterie alcaline D (non incluse). Durata > 800 ore. Stoppino mobile senza fiamma.



**Tray stand, chromed**

Stand per vassoi, cromato  
Tablett-Träger, verchromt  
Porte plateaux, chromé  
Soporte para bandejas, cromado

| art.     | dim. cm. |
|----------|----------|
| 44093-00 | 38x48x74 |



**Tray stand**

Stand per vassoi  
Tablett-Träger  
Porte plateaux  
Soporte para bandejas

| art.     | dim. cm. |
|----------|----------|
| 44093-01 | 42x43x82 |

**W**



**GN**  
**SS**

**Tray**

Vassoio  
Tablett  
Plateau  
Bandeja

| art.     | dim. cm.  | GN  |
|----------|-----------|-----|
| 41430-11 | 53x32,5x5 | 1/1 |

**Chrome plated handles. Useful height 4 cm.**  
Maniglie cromate. Altezza utile 4 cm.



**Tray**  
Vassoio  
Tablett  
Plateau  
Bandeja

| art.     | dim. cm.  | GN  |
|----------|-----------|-----|
| 41436-11 | 53x32,5   | 1/1 |
| 41436-12 | 32,5x26,5 | 1/2 |



**Fish tray**  
Vassoio pesce  
Fischplatte  
Plat à poisson  
Salmonera

| art.     | dim. cm. |
|----------|----------|
| 66345-55 | 55x23    |
| 66345-65 | 65x27    |
| 66345-74 | 74x29    |



**Fish tray**  
Vassoio pesce  
Fischplatte  
Plat à poisson  
Salmonera

| art.     | dim. cm. |
|----------|----------|
| 41654-80 | 80x31    |
| 41654-99 | 100x35   |



**Tray, oval**  
Vassoio ovale  
Tablett, oval  
Plateau ovale  
Bandeja oval

| art.     | dim. cm. |
|----------|----------|
| 41651-20 | 20x14    |
| 41651-25 | 25x18    |
| 41651-30 | 30x22    |
| 41651-35 | 35x22    |
| 41651-40 | 40x26    |



**Tray, oval**  
Vassoio ovale  
Tablett, oval  
Plateau ovale  
Bandeja oval

| art.     | dim. cm. |
|----------|----------|
| 41651-45 | 45x29    |
| 41651-50 | 50x35    |
| 41651-55 | 55x38    |
| 41651-60 | 60x42    |
| 41651-65 | 65x45    |



**Tray, round**  
Vassoio tondo  
Tablett, rund  
Plateau rond  
Bandeja redonda

| art.     | Ø cm. |
|----------|-------|
| 66326-30 | 30    |
| 66326-35 | 35    |
| 66326-40 | 40    |
| 66326-60 | 60    |
| 66326-80 | 80    |



**Tray, oval**  
Vassoio ovale  
Tablett, oval  
Plateau ovale  
Bandeja oval

| art.     | dim. cm. |
|----------|----------|
| 66325-30 | 30x19    |
| 66325-35 | 35x22    |
| 66325-41 | 41x26    |
| 66325-46 | 46x29    |
| 66325-54 | 54x37    |
| 66325-85 | 85x58    |
| 66325-99 | 100x68   |



**Tray, rectangular**  
Vassoio rettangolare  
Servierblett, rechteckig  
Plateau rectangulaire  
Bandeja rectangular

| art.     | dim. cm. |
|----------|----------|
| 66320-28 | 28x20    |
| 66320-35 | 35x30    |
| 66320-40 | 40x26    |
| 66320-50 | 50x38    |
| 66320-65 | 65x50    |
| 66320-85 | 85x50    |
| 66320-99 | 100x50   |



**Tray, rectangular**  
Vassoio rettangolare  
Servierblett, rechteckig  
Plateau rectangulaire  
Bandeja rectangular

| art.     | dim. cm. |
|----------|----------|
| 66324-40 | 40x26    |
| 66324-50 | 50x38    |
| 66324-65 | 65x50    |
| 66324-85 | 85x50    |
| 66324-99 | 100x50   |





ACACIA WOOD for a multifunctional buffet system that adapts in height and width to all space requirements. The stackable and non-slip reversible boxes can be used individually or connected with flat GN trays.

LEGNO DI ACACIA per un sistema multifunzionale che si adatta in altezza e larghezza a tutte le esigenze di spazio. Le scatole reversibili, impilabili e antiscivolo possono essere utilizzate singolarmente o collegate con i piani GN.



**Box**  
Scatola  
Wendebox  
Boîte  
Caja

| art.     | dim. cm.     | GN  |
|----------|--------------|-----|
| 42463A02 | 55,5x35x10,5 | 1/1 |



**Box**  
Scatola  
Wendebox  
Boîte  
Caja

| art.     | dim. cm.       | GN  |
|----------|----------------|-----|
| 42463A04 | 55,5x18,5x10,5 | 2/4 |



**Box**  
Scatola  
Wendebox  
Boîte

| art.     | dim. cm.   | GN  |
|----------|------------|-----|
| 42463A05 | 35x29x10,5 | 1/2 |



**Box**  
Scatola  
Wendebox  
Boîte  
Caja

| art.     | dim. cm.     | GN  |
|----------|--------------|-----|
| 42463A08 | 29x18,5x10,5 | 1/4 |



**Box**  
Scatola  
Wendebox  
Boîte  
Caja

| art.     | dim. cm.     | GN  |
|----------|--------------|-----|
| 42463B02 | 55,5x35x10,5 | 1/1 |



**Box**  
Scatola  
Wendebox  
Boîte  
Caja

| art.     | dim. cm.       | GN  |
|----------|----------------|-----|
| 42463B04 | 55,5x18,5x10,5 | 2/4 |





**Box**  
Scatola  
Wendebox  
Boîte  
Caja

art. dim. cm. GN  
42463B05 35x29x10,5 1/2



**Box**  
Scatola  
Wendebox  
Boîte  
Caja

art. dim. cm. GN  
42463B08 29x18,5x10,5 1/4



W

**Bread slicer**  
Taglia pane  
Brottschneidergerät  
Coupe-pain  
Corta-pan

art. dim. cm.  
49833-00 41x15x10



W

**Bread box**  
Cesto pane  
Brotkiste  
Caisse à pain  
Cajón para pan

art. dim. cm.  
42874-01 34x26x12,5  
42874-02 34x26x20

Beech wood. – Faggio.



W

**Bread cutting board**  
Tagliere  
Brottschneidbrett  
Planche à découper  
Tabla de corte

art. dim. cm.  
42874-03 52x34x2

Beech wood. – Faggio.



MF

**Cutting board tray**  
Vassoio per tagliere  
Schneidbrett-Tablett  
Plateau pour planche à découper  
Bandeja para tabla de corte

art. dim. cm.  
42874-04 60x35,5x3,5





**W**

**Pretzel stand**  
Porta Brezel  
Brezel-ständer  
Support à brezel  
Soporte para brezel

art.      Ø cm.    h. cm.  
42870-50    22      50

**Beechwood.** – Faggio.



**AY**

**Hygienic cover**  
Copertura igienica  
Hygieneschutz  
Couverture d'hygiène  
Cobertura d'higiene

art.      dim. cm.  
42870-51    20x20x50



**AY**

**SS**

**Bread roll-dispenser**  
Distributore panini  
Brötchen-Spender  
Distributeur à pain  
Dispensador de pan

art.      dim. cm.  
42963-55    32x22x55

**For/Per: 65-70 pcs.**



**PP**

**Bread basket**  
Cesto pane  
Brotkorb  
Corbeille à pain  
Cesta pan

| art.     | dim. cm.      | GN  | col. |
|----------|---------------|-----|------|
| 42462-11 | 53x32,5x6,5   | 1/1 | ●    |
| 42462-12 | 32,5x26,5x6,5 | 1/2 | ●    |
| 42462-13 | 32,5x17,5x6,5 | 1/3 | ●    |
| 42462-14 | 26,4x16,2x6,5 | 1/4 | ●    |
| 42462-16 | 17,6x16,2x6,5 | 1/6 | ●    |
| 42462-23 | 32,5x35,4x6,5 | 2/3 | ●    |



**PP**

**Bread basket**  
Cesto pane  
Brotkorb  
Corbeille à pain  
Cesta pan

| art.     | dim. cm.     | GN  | col. |
|----------|--------------|-----|------|
| 42463-11 | 53x32,5x10   | 1/1 | ●    |
| 42463-12 | 32,5x26,5x10 | 1/2 | ●    |
| 42463-13 | 32,5x17,5x10 | 1/3 | ●    |
| 42463-14 | 26,4x16,2x10 | 1/4 | ●    |
| 42463-16 | 17,6x16,2x10 | 1/6 | ●    |
| 42463-23 | 32,5x35,4x10 | 2/3 | ●    |



**PP**

**Bread basket**  
Cesto pane  
Brotkorb  
Corbeille à pain  
Cesta pan

| art.     | dim. cm.      | GN  | col. |
|----------|---------------|-----|------|
| 42967-63 | 53x32,5x6,5   | 1/1 | ●    |
| 42967-64 | 32,5x26,5x6,5 | 1/2 | ●    |
| 42967-65 | 32,5x17,5x6,5 | 1/3 | ●    |
| 42967-66 | 26,4x16,2x6,5 | 1/4 | ●    |
| 42967-67 | 17,6x16,2x6,5 | 1/6 | ●    |
| 42967-68 | 32,5x35,4x6,5 | 2/3 | ●    |



**PP**

**Bread basket**  
Cesto pane  
Brotkorb  
Corbeille à pain  
Cesta pan

| art.     | dim. cm.     | GN  | col. |
|----------|--------------|-----|------|
| 42967-73 | 53x32,5x10   | 1/1 | ●    |
| 42967-74 | 32,5x26,5x10 | 1/2 | ●    |
| 42967-75 | 32,5x17,5x10 | 1/3 | ●    |
| 42967-76 | 26,4x16,2x10 | 1/4 | ●    |
| 42967-77 | 17,6x16,2x10 | 1/6 | ●    |
| 42967-78 | 32,5x35,4x10 | 2/3 | ●    |



**Bread basket**

Cesto pane  
Brotkorb  
Corbeille à pain  
Cesta pan

| art.     | dim. cm.      | GN  | col. |
|----------|---------------|-----|------|
| 42967-03 | 53x32,5x6,5   | 1/1 | ●    |
| 42967-04 | 32,5x26,5x6,5 | 1/2 | ●    |
| 42967-05 | 32,5x17,5x6,5 | 1/3 | ●    |
| 42967-06 | 26,4x16,2x6,5 | 1/4 | ●    |
| 42967-07 | 17,6x16,2x6,5 | 1/6 | ●    |
| 42967-08 | 32,5x35,4x6,5 | 2/3 | ●    |

**Bread basket**

Cesto pane  
Brotkorb  
Corbeille à pain  
Cesta pan

| art.     | dim. cm.     | GN  | col. |
|----------|--------------|-----|------|
| 42967-13 | 53x32,5x10   | 1/1 | ●    |
| 42967-14 | 32,5x26,5x10 | 1/2 | ●    |
| 42967-15 | 32,5x17,5x10 | 1/3 | ●    |
| 42967-16 | 26,4x16,2x10 | 1/4 | ●    |
| 42967-17 | 17,6x16,2x10 | 1/6 | ●    |
| 42967-18 | 32,5x35,4x10 | 2/3 | ●    |



42973-61



**Bread basket**

Cesto pane  
Brot-Korb  
Corbeille à pain  
Cesta pan

| art.     | dim. cm. | h. cm. |
|----------|----------|--------|
| 42973-30 | 30x40    | 16/27  |

**Bread basket**

Cesto pane  
Brot-Korb  
Corbeille à pain  
Cesta pan

| art.     | dim. cm. | h. cm. |
|----------|----------|--------|
| 42973-45 | 45x40    | 16/27  |
| 42973-61 | divider  |        |

**Bread basket**

Cesto pane  
Brot-Korb  
Corbeille à pain  
Cesta pan

| art.     | dim. cm. | h. cm. |
|----------|----------|--------|
| 42973-60 | 60x40    | 16/27  |



**French stick bread basket**

Cesta baguettes  
Brotkorb für Baguette  
Corbeille à baguettes  
Cesta pan francés

| art.     | Ø cm. | h. cm. |
|----------|-------|--------|
| 42967-35 | 35    | 25/42  |

**French stick bread basket**

Cesta baguettes  
Brotkorb für Baguette  
Corbeille à baguettes  
Cesta pan francés

| art.     | Ø cm. | h. cm. |
|----------|-------|--------|
| 42972-28 | 30    | 38     |

**Bread basket**

Cesto pane  
Brotkorb  
Corbeille à pain  
Cesta pan

| art.     | Ø cm. | h. cm. |
|----------|-------|--------|
| 42968-38 | 38    | 10     |





PP

**Bread basket**

Cesto pane  
Brotkorb  
Corbeille à pain  
Cesta pan

| art.     | Ø cm. | h. cm. |
|----------|-------|--------|
| 42968-42 | 42    | 12     |



PP

**Bread basket**

Cesto pane  
Brotkorb  
Corbeille à pain  
Cesta pan

| art.     | Ø cm. | h. cm. |
|----------|-------|--------|
| 42969-31 | 31/37 | 6/12   |



PP

**Bread basket**

Cesto pane  
Brotkorb  
Corbeille à pain  
Cesta pan

| art.     | Ø cm. | h. cm. |
|----------|-------|--------|
| 42969-36 | 36,5  | 12     |



PP

**Bread basket**

Cesto pane  
Brotkorb  
Corbeille à pain  
Cesta pan

| art.     | dim. cm. | h. cm. |
|----------|----------|--------|
| 42967-43 | 45x42    | 17/24  |



PP

**Bread basket**

Cesto pane  
Brotkorb  
Corbeille à pain  
Cesta pan

| art.     | dim. cm. |
|----------|----------|
| 42972-01 | 40x20x5  |
| 42972-02 | 40x30x5  |
| 42972-03 | 60x20x5  |
| 42972-04 | 60x40x5  |



PP

**Bread basket**

Cesto pane  
Brotkorb  
Corbeille à pain  
Cesta pan

| art.     | dim. cm.     |
|----------|--------------|
| 42967-53 | 53x32,5x15,5 |



PP

**Bread basket**

Cesto pane  
Brotkorb  
Corbeille à pain  
Cesta pan

| art.     | dim. cm. |
|----------|----------|
| 42936-23 | 23x19x9  |



PP

**Bread basket**

Cesto pane  
Brotkorb  
Corbeille à pain  
Cesta pan

| art.     | dim. cm.  |
|----------|-----------|
| 42936-24 | 24x17x8   |
| 42936-28 | 28x16x8,5 |



PP

**Bread basket**

Cesto pane  
Brotkorb  
Corbeille à pain  
Cesta pan

| art.     | dim. cm.  |
|----------|-----------|
| 42946-23 | 23x10x6   |
| 42946-37 | 37,5x15x7 |



PP

**Bread basket**

Cesto pane  
Brotkorb  
Corbeille à pain  
Cesta pan

| art.     | dim. cm. |
|----------|----------|
| 42947-23 | 23x15x7  |
| 42947-30 | 30x22x7  |
| 42947-40 | 41x29x7  |



PP

**Bread basket**

Cesto pane  
Brotkorb  
Corbeille à pain  
Cesta pan

| art.     | dim. cm.      | GN  |
|----------|---------------|-----|
| 42969-11 | 53,5x32,5x9,5 | 1/1 |



PP

**Bread basket**

Cesto pane  
Brotkorb  
Corbeille à pain  
Cesta pan

| art.     | dim. cm.    | GN  |
|----------|-------------|-----|
| 42965-12 | 32,5x26,5x8 | 1/2 |



**Bread basket**

Cesto pane  
Brotkorb  
Corbeille à pain  
Cesta pan

art. dim. cm. GN  
42967-11 56,5x36x10 1/1

**With frame to fix the cover.**  
Con telaio per fissare il coperchio.



**Roll-top cover**

Coperchio roll-top  
Rolltophaube  
Couvercle roll-top  
Tapa roll-top

art. dim. cm. GN  
41415-11 53x32,5x17 1/1

**Chrome knob. – Pomolo cromato.**



**Bread basket**

Cesto pane  
Brotkorb  
Corbeille à pain  
Cesta pan

art. dim. cm. GN  
42461-11 56,5x36x10 1/1

**With frame to fix the cover.**  
Con telaio per fissare il coperchio.



**Roll-top cover**

Coperchio roll-top  
Rolltophaube  
Couvercle roll-top  
Tapa roll-top

art. dim. cm. GN  
42452-53 53x32,5x17 1/1

**Chrome knob. – Pomolo cromato.**



**Bread basket**

Cesto pane  
Brotkorb  
Corbeille à pain  
Cesta pan

art. Ø cm. h. cm.  
42461-35 35 20

**With frame to fix the cover.**  
Con telaio per fissare il coperchio.



**Roll-top cover**

Coperchio roll-top  
Rolltophaube  
Couvercle roll-top  
Campana roll-top

art. Ø cm. h. cm.  
42452-35 38 20



**Cover**

Coperchio  
Kuppelhaube  
Couvercle  
Campana

art. dim. cm. GN  
41419-12 33x28x17 1/2

**One front cut. – Con apertura frontale.**



**Cover**

Coperchio  
Kuppelhaube  
Couvercle  
Campana

art. dim. cm. GN  
41418-11 54x33x20 1/1

**One front cut. – Con apertura frontale.**



**Cover**

Coperchio  
Kuppelhaube  
Couvercle  
Campana

art. dim. cm. GN  
41418-12 54x33x20 1/1

**Totally closed. – Chiuso.**



**Bread basket**

Cesto pane  
Brotkorb  
Corbeille à pain  
Cesta pan

art. dim. cm. col.  
42991-25 25x19x6,5 ●  
42991-32 32x23x7 ●



**Bread basket**

Cesto pane  
Brotkorb  
Corbeille à pain  
Cesta pan

art. dim. cm. col.  
42991M25 25x19x6,5 ●  
42991M32 32x23x7 ●



**Bread basket**

Cesto pane  
Brotkorb  
Corbeille à pain  
Cesta pan

art. dim. cm. col.  
42991N25 25x19x6,5 ●  
42991N32 32x23x7 ●







**Bread basket**

Cesto pane  
Brotkorb  
Corbeille à pain  
Cesta pan

| art.     | dim. cm. | col. |
|----------|----------|------|
| 42993-40 | 40X30X10 | ●    |
| 42993M40 | 40X30X10 | ●    |
| 42993N40 | 40X30X10 | ●    |



**Bread basket**

Cesto pane  
Brotkorb  
Corbeille à pain  
Cesta pan

| art.     | Ø cm. | h. cm. | col. |
|----------|-------|--------|------|
| 42990-16 | 16    | 8      | ●    |
| 42990-20 | 20    | 8      | ●    |
| 42990-29 | 29    | 7      | ●    |



**Bread basket**

Cesto pane  
Brotkorb  
Corbeille à pain  
Cesta pan

| art.     | Ø cm. | h. cm. | col. |
|----------|-------|--------|------|
| 42990M16 | 16    | 8      | ●    |
| 42990M20 | 20    | 8      | ●    |
| 42990M29 | 29    | 7      | ●    |



**Bread basket**

Cesto pane  
Brotkorb  
Corbeille à pain  
Cesta pan

| art.     | Ø cm. | h. cm. | col. |
|----------|-------|--------|------|
| 42990N16 | 16    | 8      | ●    |
| 42990N20 | 20    | 8      | ●    |
| 42990N29 | 29    | 7      | ●    |



**Bread basket stand**

Alzata ceste  
Körbe-Gestell  
Étagère à corbeilles  
Soporte ceste pan

| art.     | dim. cm.   |
|----------|------------|
| 42870-59 | 30,5x59x58 |

**For baskets 42968-38 and 42967-13.**  
Per cesti 42968-38 e 42967-13.



**Wire stand chrome plated, 2 tiers**

Supporto filo cromato, 2 piani  
Brotkorb-Drahtgestell, Doppeldecker  
Support en fil chromé, 2 étages  
Estructura alambre cromado, 2 alturas

| art.     | dim. cm. | GN  |
|----------|----------|-----|
| 42872-02 | 46x24x21 | 1/2 |

**For baskets/Per cesti:**  
**42965-12, 42967- 04-14-64-74.**



**Wire stand black, 2 tiers**

Supporto filo nero, 2 piani  
Brotkorb-Drahtgestell, Doppeldecker  
Support en fil noir, 2 étages  
Estructura alambre negro, 2 alturas

| art.     | dim. cm.   | GN  |
|----------|------------|-----|
| 41220-06 | 44,5x26x22 | 1/2 |



**Basket with black wire stand**

Cesto con supporto filo nero  
Korbdrahtgestell, schwarz  
Panier support en fil noir  
Cesta estructura alambre negro

| art.     | dim. cm. |
|----------|----------|
| 41220-02 | 40x30    |
| 41220-03 | 60x40    |

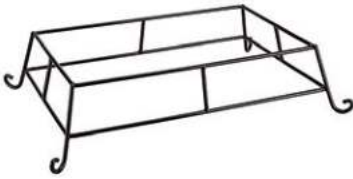

**Wire stand black**

Supporto filo nero  
Drahtgestell, schwarz  
Support en fil noir

Estructura alambre negro

| art.     | dim. cm.     | GN  |
|----------|--------------|-----|
| 41220-07 | 49,5x30x13,5 | 1/1 |



PP

**Basket with black wire stand**

Cesto con supporto filo nero  
Korbdrahtgestell, schwarz  
Panier support en fil noir  
Cesta estructura alambre negro

| art.     | Ø cm. | h. cm. |
|----------|-------|--------|
| 41220-01 | 38    | 15,5   |



PP

**Basket with black wire stand**

Cesto con supporto filo nero  
Korbdrahtgestell, schwarz  
Panier support en fil noir  
Cesta estructura alambre negro

| art.     | Ø cm. | h. cm. |
|----------|-------|--------|
| 41220-04 | 33    | 15,5   |



PP

**Basket with black wire stand**

Cesto con supporto filo nero  
Korbdrahtgestell, schwarz  
Panier support en fil noir  
Cesta estructura alambre negro

| art.     | Ø cm. | h. cm. |
|----------|-------|--------|
| 41220-05 | 43    | 15,5   |



**Round canvas bag**

Cesto cotone, rotondo  
Brottasche, rund, Baumwolle  
Panier à pain, coton  
Cesta pan, algodón

| art.     | Ø cm. | h. cm. | col. |
|----------|-------|--------|------|
| 42873-02 | 20    | 23,5   | ●    |

**Stone pillow included. Easy to heat up in microwave for 90 sec. at 500 Watt. Machine washable up to 30°C (except pillow).**

Cuscino noccioli di ceramica incluso. Scaldare in microonde per 90 secondi a 500 Watt. Lavabile in lavatrice max 30°C (escluso cuscino).



R

**Egg basket, keeps warm**

Cesto uova, imbottito  
Eier-Korb, hält warm  
Panier à oeufs, fourré  
Cesta para huevos

| art.     | Ø cm. | h. cm. |
|----------|-------|--------|
| 42949-26 | 26    | 17     |

For around 20 eggs. – Per c.ca 20 uova.



**Sign holders, chromed**

Clip flessibili, cromate  
Schildhalter, verchromt  
Porte-étiquettes, chromés  
Porta etiquetas con clip, cromate

| art.     | l. cm. | pcs/pz |
|----------|--------|--------|
| 41394-02 | 12     | 2      |



**Chalkmarker**

Penna a gesso liquido  
Kreidestifte  
Stylo à craie liquide  
Rotulador de tiza líquida

| art.     | Ø mm. | col. |
|----------|-------|------|
| 47832-00 | 5     | ○    |
| 47832-01 | 5     | ●    |
| 47832-02 | 5     | ●    |
| 47832-03 | 5     | ●    |
| 47832-04 | 5     | ●    |
| 47832-05 | 5     | ●    |

**Clean with water. Writes on all non porous surfaces. – Pulire con acqua. Scrive su tutte le superfici non porose.**





**Chalkmarker**

Penna a gesso liquido

Kreidestifte

Stylo à craie liquide

Rotulador de tiza líquida

| art.     | Ø mm. | col. |
|----------|-------|------|
| 47832-10 | 15    | ○    |
| 47832-11 | 15    | ●    |
| 47832-12 | 15    | ●    |
| 47832-13 | 15    | ●    |
| 47832-14 | 15    | ●    |
| 47832-15 | 15    | ●    |



W  
SAN  
SS

**Showplate, 3-pcs set**

Vetrina, set 3 pezzi

Buffetvitrine, 3-teilig

Etagère, set 3 pièces

Vitrina, 3 elementos

| art.     | Ø cm. | h. cm. |
|----------|-------|--------|
| 41429-04 | 45    | 24     |



SAN

**Roll-top cover**

Coperchio roll-top

Rolltophaube

Couvercle roll-top

Campana roll-top

| art.     | Ø cm. | h. cm. |
|----------|-------|--------|
| 41447-38 | 38    | 20     |

Chrome knob. – Pomolo cromato.



SAN  
SS

**Showplate, 2-pcs set**

Vetrina, set 2 pezzi

Buffetvitrine, 2-teilig

Etagère, set 2 pièces

Vitrina, 2 elementos

| art.     | Ø cm. | h. cm. |
|----------|-------|--------|
| 41447-02 | 38    | 21     |



SN  
SAN  
SS

**Showplate, 5-pcs set**

Vetrina, set 5 pezzi

Buffetvitrine, 5-teilig

Etagère, set 5 pièces

Vitrina, 5 elementos

| art.     | Ø cm. | h. cm. |
|----------|-------|--------|
| 41447-05 | 38    | 24     |



SN  
W  
SAN  
SS

**Showplate, 3-pcs set**

Vetrina, set 3 pezzi

Buffetvitrine, 3-teilig

Etagère, set 3 pièces

Vitrina, 3 elementos

| art.     | Ø cm. | h. cm. |
|----------|-------|--------|
| 41905-38 | 43    | 4,5    |

Roll-top 41447-38 not included.

Coperchio 41447-38 non incl.



SN  
SN  
SS

**Showcase, 3-pcs set**

Vetrina, set 3 pezzi

Buffetvitrine, 3-teilig

Etagère, set 3 pièces

Vitrina, 3 elementos

| art.     | Ø cm. | h. cm. | col. |
|----------|-------|--------|------|
| 41944-06 | 38    | 6      | ○    |
| 41944B06 | 38    | 6      | ●    |



SAN

**Roll-top cover**

Coperchio roll-top

Rolltophaube

Couvercle roll-top

Campana roll-top

| art.     | Ø cm. | h. cm. |
|----------|-------|--------|
| 41945-38 | 38    | 20     |



PC

**Roll-top cover**  
Coperchio roll-top  
Rolltophaube  
Couvercle roll-top  
Campana roll-top

art. dim. cm. GN  
41415-10 53x32,5x17 1/1

**Gold plated knob. – Barretta dorata.**



PC

**Roll-top cover**  
Coperchio roll-top  
Rolltophaube  
Couvercle roll-top  
Campana roll-top

art. dim. cm. GN  
41415-11 53x32,5x17 1/1

**Chrome knob. – Pomolo cromato.**



SS

**Showplate, 4-pcs set**  
Vetrina, set 4 pezzi  
Buffetvitrine, 4-teilig  
Etagère, set 4 pièces  
Vitrina, 4 elementos

art. dim. cm. GN  
41907-56 56,5x36x8,5 1/1

**Box + tray GN 1/1 + 2 cooler, without rolltop cover  
41415-11. – Base + vassoio + 2 eutettici, coperchio  
41415-11 non incl.**



W

**Showplate, 4-pcs set**  
Vetrina, set 4 pezzi  
Buffetvitrine, 4-teilig  
Etagère, set 4 pièces  
Vitrina, 4 elementos

art. dim. cm.  
41906-60 60x41x5

**Box + tray GN 1/1 + 2 cooler, without rolltop cover  
41415-11. – Base + vassoio + 2 eutettici, coperchio  
41415-11 non incl.**



W

PP

PS

**Ice-box, 3 pcs set**  
Box portaghiaccio, set 3 pz  
Eisbox, 3-teilig  
Boîte à glaçons, 3 pièces  
Cubitera, 3 elementos

art. dim. cm.  
41412-11 53x32,5x12,5

**Box wenge + plastic deep tray + drainer plate.  
Base wengé + vasca plastica + griglia.**



SS

**Showplate, 4-pcs set**  
Vetrina, set 4 pezzi  
Buffetvitrine, 4-teilig  
Etagère, set 4 pièces  
Vitrina, 4 elementos

art. dim. cm. col.  
41940-06 43,5x32,5x6 ○  
41940B06 43,5x32,5x6 ●

**Box, tray, 2 coolers.**  
Contenitore, vassoio, 2 eutettici.



SAN

**Roll-top cover**  
Coperchio roll-top  
Rolltophaube  
Couvercle roll-top  
Campana roll-top

art. dim. cm.  
41941-44 44x33,5x17

**For showcases 41940-06, 41940B06.  
Per vetrine 41940-06, 41940B06.**



W

**Cutting board**  
Tagliere  
Schneidebrett  
Planche à découper  
Tabla de corte

art. dim. cm.  
41941-43 43,5x32,5x2

**For showcases 41940-06, 41940B06.  
Per vetrine 41940-06, 41940B06.**



SS

**Cool plate**  
Vetrina refrigerata  
Buffet-Vitrine, kühlbar  
Vitrine réfrigérée  
Vitrina refrigerada

art. dim. cm. GN  
42450-00 53x32,5x8,5 1/1

**GN 1/1 base element, s/s platter, cooler.**  
Base GN 1/1, vassoio inox, eutettico.





**BUFFET**



**Cool plate**

Vetrina refrigerata  
Buffet-Vitrine, kühlbar  
Vitrine réfrigérée  
Vitrina refrigerada

art. dim. cm. GN  
42460-00 53x32,5x8,5 1/1

**GN 1/1 base element, s/s platter, cooler.**  
Base GN 1/1, vassoio inox, eutettico.



**Cool plate**

Vetrina refrigerata  
Buffet-Vitrine, kühlbar  
Vitrine réfrigérée  
Vitrina refrigerada

art. dim. cm. GN  
42470-00 53x32,5x8,5 1/1

**GN 1/1 base element, s/s platter, cooler.**  
Base GN 1/1, vassoio inox, eutettico.



**Eutectic pad**

Accumulatore di freddo  
Kühlakku  
Cartouche eutectique  
Placa eutética

art. dim. cm.  
42450-AD 41x21x2,5



**GN roll-top cover**

Coperchio GN roll-top  
GN-Rolltophaube  
Couvercle roll-top, GN  
Tapa roll-top, GN

art. GN  
42452-53 1/1



**Tray**

Vassoio  
Tablett  
Plateau  
Bandeja

art. GN  
42451-11 1/1  
42451-12 1/2



**Cutting board**

Tagliere  
Tranchierbrett  
Planche à découper  
Plancha para cortar

art. GN  
42470-06 1/1



**Cutting board**

Tagliere  
Tranchierbrett  
Planche à découper  
Plancha para cortar

art. GN  
42460-06 1/1



**Cooled buffet showcase**

Vetrina refrigerata  
Buffet-Vitrine, kühlbar  
Vitrine réfrigérée  
Vitrina refrigerada

art. dim. cm. col.  
42470-63 63,5x42,5x31 ●

**Woodabse with fixed roll-top cover, plastic case, GN 1/1 melamine tray, cooling unit.** – Base legno con coperchio roll-top fisso, vasca plastica, GN 1/1 in melamina, placca eutettica.



**Cooled buffet showcase**

Vetrina refrigerata  
Buffet-Vitrine, kühlbar  
Vitrine réfrigérée  
Vitrina refrigerada

art. dim. cm. col.  
42460-63 63,5x42,5x31 ●

**Woodabse with fixed roll-top cover, plastic case, GN 1/1 melamine tray, cooling unit.** – Base legno con coperchio roll-top fisso, vasca plastica, GN 1/1 in melamina, placca eutettica.



**Cutlery dispenser**

Portaposate  
Besteck-Behälter  
Bac à couverts  
Caja portacubiertos

art. dim. cm. col.  
42470-64 57,5x37x12 ●



**Cutlery dispenser**

Portaposate  
Besteck-Behälter  
Bac à couverts  
Caja portacubiertos

art. dim. cm. col.  
42460-64 57,5x37x12 ●



**Bowl**

Ciotola  
Schüssel  
Bol  
Bol

| art.     | Ø cm. | h. cm. | lt. | col. |
|----------|-------|--------|-----|------|
| 44837B05 | 14    | 6,5    | 0,5 | ●    |
| 44837B20 | 20    | 9,2    | 1,8 | ●    |
| 44837B25 | 23    | 10,0   | 2,5 | ●    |



MF

**Bowl**

Ciotola  
Schüssel  
Bol  
Bol

| art.     | Ø cm. | h. cm. | lt. | col. |
|----------|-------|--------|-----|------|
| 44837-05 | 14    | 6,5    | 0,5 | ○    |
| 44837-20 | 20    | 9,2    | 1,8 | ○    |
| 44837-25 | 23    | 10,0   | 2,5 | ○    |



**Bowl, glass**

Ciotola, vetro  
Glasschüssel  
Bol en verre  
Bol vidrio

| art.     | Ø cm. | h. cm. | lt.  |
|----------|-------|--------|------|
| 41425-AA | 7,5   | 3,5    | 0,09 |
| 41405-AA | 14,0  | 6,5    | 0,5  |
| 41400-AA | 23,0  | 10,0   | 2,5  |



PC

**Airtight cover**

Coperchio ermetico  
Frischhaltedeckel  
Couvercle hermétique  
Tapa hermética

| art.     | Ø cm. |
|----------|-------|
| 42452-14 | 14    |
| 42452-23 | 23    |



PC

**Cover**

Coperchio  
Deckel  
Couvercle  
Tapa

| art.     | Ø cm. |
|----------|-------|
| 42453-23 | 23    |



SAN

**Cover**

Coperchio  
Deckel  
Couvercle  
Tapa

| art.     | Ø cm. |
|----------|-------|
| 44837C20 | 20,5  |

Matches/Per: 44837-20 & 44837B20.



W

W

**Cool bowl**

Ciotola refrigerata  
Kühlschale  
Bol réfrigérée  
Bol refrigerda

| art.     | dim. cm.     | lt. | col. |
|----------|--------------|-----|------|
| 42470-27 | 27,5x27,5x14 | 2,5 | ●    |

Wood base, s/s container, melamine bowl, cooling unit. – Base legno, contenitore inox, ciotola melamina, placca eutettica.



W

W

**Cool bowl**

Ciotola refrigerata  
Kühlschale  
Bol réfrigérée  
Bol refrigerda

| art.     | dim. cm.     | lt. | col. |
|----------|--------------|-----|------|
| 42460-27 | 27,5x27,5x14 | 2,5 | ●    |

Wood base, s/s container, melamine bowl, cooling unit. – Base legno, contenitore inox, ciotola melamina, placca eutettica.





AY

PC

SS

**Cool bowl**

Ciotola refrigerata  
Kühlschale  
Bol réfrigérée  
Bol refrigerda

| art.     | Ø cm. | h. cm. | lt. |
|----------|-------|--------|-----|
| 41448-06 | 14    | 9,0    | 0,6 |
| 41448-10 | 14    | 11,5   | 1,0 |

**Base + cooler + bowl + cover.**

Base + eutettico + ciotola + coperchio.



AY

PC

SS

**Cool bowl**

Ciotola refrigerata  
Kühlschale  
Bol réfrigérée  
Bol refrigerda

| art.     | Ø cm. | h. cm. | lt. |
|----------|-------|--------|-----|
| 41448-25 | 22    | 14     | 2,5 |
| 41448-40 | 22    | 18     | 4,0 |

**Base + cooler + bowl + cover.**

Base + eutettico + ciotola + coperchio.



**Buffet stand, chrome plated**

Alzata, cromata  
Buffet-Gestell, Metall hartverchromt  
Présentoir, chromé  
Soporte, cromado

| art.     | dim. cm. |
|----------|----------|
| 41442-03 | 61x24x35 |

**3 glass bowls ø cm 23 + 3 covers.**

3 ciotole ø cm 23 + covers.



**Serving stand, chrome plated**

Supporto cromato  
Serviergestell, hartverchromt  
Présentoir, acier chromé  
Soporte platos, acero cromado

| art.     | dim. cm. |
|----------|----------|
| 44840-06 | 39x39x17 |

**For bowls/Per ciotole: 12,5x12,5 e 25x25 cm.**



**Serving stand, chrome plated**

Supporto cromato  
Serviergestell, hartverchromt  
Présentoir, acier chromé  
Soporte platos, acero cromado

| art.     | dim. cm.     |
|----------|--------------|
| 44840-07 | 55,5x19x15,5 |

**For bowls 19x19 cm. NOT included.**

Per ciotole 19x19 cm. NON include.



MF

**Bowl**

Ciotola  
Schüssel  
Bol  
Bol

| art.     | dim. cm.    |
|----------|-------------|
| 44884-12 | 12,5x12,5x6 |
| 44884-19 | 19x19x9,5   |
| 44884-25 | 25x25x12    |



MF

**Bowl**

Ciotola  
Schüssel  
Bol  
Bol

| art.     | dim. cm.    |
|----------|-------------|
| 44884B12 | 12,5x12,5x6 |
| 44884B19 | 19x19x9,5   |
| 44884B25 | 25x25x12    |



SAN

**Cover**

Coperchio  
Deckel  
Couvercle  
Tapa

| art.     | dim. cm. |
|----------|----------|
| 44885-19 | 19x19    |
| 44885-25 | 25x25    |



**Buffet stand, chrome plated**

Alzata, cromata  
Buffet-Gestell, Metall hartverchromt  
Présentoir, chromé  
Soporte, cromado

art. dim. cm.

41442-14 30x30x14

**3 glass bowls ø cm 14 + 3 covers.**  
3 ciotole ø cm 14 + covers.



**Buffet stand, chrome plated**

Alzata, cromata  
Buffet-Gestell, Metall hartverchromt  
Présentoir, chromé  
Soporte, cromado

art. dim. cm.

41442-23 50x50x18

**3 glass bowls ø cm 23 + 3 covers.**  
3 ciotole ø cm 23 + covers.



**Bowl holder, chromed**

Portaciotole, cromato  
Schalenhalter, Metall hartverchromt  
Etagère à bols, chromée  
Soporte para bols, cromado

art. Ø cm. h. cm.

41427-40 18 25,5

**For 36 bowls ø cm 7 # 41425-AA.**  
Per 36 ciotoline ø cm 7 # 41425-AA.



**Serving stand, chrome plated**

Alzata, cromata  
Serviergestell, Metall hartverchromt  
Présentoir, chromé  
Soporte platos para buffet, cromado

art. Ø cm. h. cm.

42962-04 34 37

**For 4 plates max. Ø 31 cm, inside Ø 23,5 cm.**



**Serving stand, chrome plated**

Alzata, cromata  
Serviergestell, Metall hartverchromt  
Présentoir, chromé  
Soporte platos, cromado

art. dim. cm. col.

42962C26 18,5x15,5x26 ●

42962C44 29x19,5x43 ●

**26: for 3 plates max. Ø 17 cm, inside Ø 10,5 cm**  
**44: for 3 plates max. Ø 27 cm, inside Ø 18 cm**



**Serving stand**

Alzata  
Serviergestell  
Présentoir  
Soporte platos

art. dim. cm.

42962-26 18,5x15,5x26

42962-30 29x19,5x30

42962-44 29x19,5x43

**26: for 3 plates max. Ø 17 cm, inside Ø 10,5 cm**  
**30: for 2 plates max. Ø 27 cm, inside Ø 18 cm**  
**44: for 3 plates max. Ø 27 cm, inside Ø 18 cm**



**Plate cover**

Copripiatto  
Tellerabdeckhaube  
Cloche  
Cubreplatos

art. Ø cm. h. cm. fits/per  
44991-24 24 7,5 Ø 22,5-23

**NEW**

**SAN**



**Fruit stand**

Espositore porta frutta  
Obstspender  
Etagère à fruits  
Expositor frutas

art. Ø cm. h. cm.  
41449-27 27,5 32

**FE**

**SS**







FE

SS

**Fruit stand**

Espositore porta frutta  
Obstspender  
Etagère à fruits  
Expositor frutas

| art.     | Ø cm. | h. cm. |
|----------|-------|--------|
| 41449-32 | 32    | 53     |



SS

**Fruit stand**

Alzata Royale  
Obständer  
Etagère Royale  
Expositor de frutas

| art.     | Ø cm.    | h. cm. |
|----------|----------|--------|
| 41820-03 | 24-33-42 | 50     |



**Buffet ladder, chrome plated**

Espositore buffet, cromato  
Büffet-Leiter, verchromt  
Escalier à buffet, chromé  
Escalera para buffet, cromada

| art.     | dim. cm. |
|----------|----------|
| 41912-03 | 30x30x48 |

**With 4 bowls ø cm 14 + lids.**  
Con 4 ciotole ø cm 14 + coperchi.



**Buffet ladder, chrome plated**

Espositore buffet, cromato  
Büffet-Leiter, verchromt  
Escalier à buffet, chromé  
Escalera para buffet, cromada

| art.     | dim. cm. |
|----------|----------|
| 41912-04 | 30x30x48 |

**With 6 bowls ø cm 14.** – Con 6 ciotole ø cm 14.



**Buffet ladder, chrome plated**

Espositore buffet, cromato  
Büffet-Leiter, verchromt  
Escalier à buffet, chromé  
Escalera para buffet, cromada

| art.     | dim. cm. |
|----------|----------|
| 41913-03 | 39x31x66 |

**With 4 bowls ø cm 23 + lids.**  
Con 4 ciotole ø cm 23 + coperchi.



**Buffet ladder, chrome plated**

Espositore buffet, cromato  
Büffet-Leiter, verchromt  
Escalier à buffet, chromé  
Escalera para buffet, cromada

| art.     | dim. cm. |
|----------|----------|
| 41913-04 | 39x31x66 |

**With 6 bowls ø cm 23.** – Con 6 ciotole ø cm 23.



**Buffet ladder, chrome plated**

Espositore buffet, cromato  
Büffet-Leiter, verchromt  
Escalier à buffet, chromé  
Escalera para buffet, cromada

| art.     | dim. cm.   | GN  |
|----------|------------|-----|
| 41403-01 | 31,5x32x48 | 1/3 |

**For GN pans see pages 72-73.**  
Per contenitori GN vedi pagg 72-73.



**Buffet ladder, chrome plated**

Espositore buffet, cromato  
Büffet-Leiter, verchromt  
Escalier à buffet, chromé  
Escalera para buffet, cromada

| art.     | dim. cm.     | GN  |
|----------|--------------|-----|
| 41403-02 | 31,5x41,5x48 | 1/2 |

**For baskets see pages 422/423.**  
Per cesti vedi pagg 422-423.



**Buffet ladder, chrome plated**

Espositore buffet, cromato  
Büffet-Leiter, verchromt  
Escalier à buffet, chromé  
Escalera para buffet, cromada

art. dim. cm. GN  
41403-03 31,5x56x66 1/2

**For baskets see pages 422/423.**  
Per cesti vedi pagg 422-423.



**Buffet ladder, chrome plated**

Espositore buffet, cromato  
Büffet-Leiter, verchromt  
Escalier à buffet, chromé  
Escalera para buffet, cromada

art. dim. cm. GN  
41403-04 52x59x66 1/1

**For GN pans see pages 72-73.**  
Per contenitori GN vedi pagg 72-73.



SAN

AY

**Multi rack**

Multi-distributore  
Multi Rack  
Distributeur  
Dispensador

art. dim. cm.  
41908-01 26x18x43



SAN

W

**Multi rack**

Multi-distributore  
Multi Rack  
Distributeur  
Dispensador

art. dim. cm.  
41908-00 26x18x43



SAN

SS

**Multi rack**

Multi-distributore  
Multi Rack  
Distributeur  
Dispensador

art. dim. cm.  
41911-02 19x24x28



SAN

SS

**Multi rack**

Multi-distributore  
Multi Rack  
Distributeur  
Dispensador

art. dim. cm.  
41911-03 19x24x41





**SAN**  
**SS**

**Multi rack**  
Multi-distributore  
Multi Rack  
Distributeur  
Dispensador

art. dim. cm.  
41911-04 19x24x53

**For additional canisters and slide see page 527.**  
Per contenitori supplementari e scivolo vedi pag 527.



**W**

**Buffet stand**  
Espositore buffet  
Buffetgestell  
Présentoir  
Expositor de buffet

art. dim. cm.  
42460-53 53x21x50

**Shelves/Ripiani: 30 x 15 - 40 x 17,5 - 53 x 19 cm.**



**W**

**Buffet stand**  
Espositore buffet  
Buffetgestell  
Présentoir  
Expositor de buffet

art. dim. cm.  
42470-53 53x21x50

**Shelves/Ripiani: 30 x 15 - 40 x 17,5 - 53 x 19 cm.**



**W**  
**AR**

**Serving stand 2-tier**  
Alzata 2 piani  
Servierstand 2-stufig  
Support 2 niveaux  
Soporte 2 pisos

art. dim. cm.  
41207-02 25x4,5x34,5

**Beech. Slate cm. 31x13 - 41x18.**  
Faggio. Ardesia cm. 31x13 - 41x18.



**W**  
**AR**

**Serving stand 3-tier**  
Alzata 3 piani  
Servierstand 3-stufig  
Support 3 niveaux  
Soporte 3 pisos

art. dim. cm.  
41207-03 25x4,5x54

**Beech. Slate cm. 21x8 - 31x13 - 41x18.**  
Faggio. Ardesia cm. 21x8 - 31x13 - 41x18.



**W**

**Stand**  
Alzata  
Ständer  
Support  
Soporte

art. dim. cm.  
42463A00 20x20x17,5

**Acacia wood.**



**W**

**Stand**  
Alzata  
Ständer  
Support  
Soporte

art. dim. cm.  
42463B00 20x20x17,5

**Acacia wood.**





W

**Stand**

Alzata  
Ständer  
Support  
Soporte

| art.     | Ø cm. | h. cm. |
|----------|-------|--------|
| 41445-01 | 15    | 10     |
| 41445-02 | 35    | 15     |

Acacia wood. – Fig. bowls/ciotole 41445.



W

**Cereal-bar**

Espositore cereali  
Cerealien-Buffer-Ständer  
Présentoir à céréales  
Expositor de cereale

| art.     | dim. cm.   | col. |
|----------|------------|------|
| 42470-43 | 43x17x13,5 | ●    |

3 glasses lt. 2 with airtight cover.  
3 vasi lt. 2 con coperchio ermetico.



W

**Cereal-bar**

Espositore cereali  
Cerealienständer  
Présentoir à céréales  
Expositor de cereales

| art.     | dim. cm.   | col. |
|----------|------------|------|
| 42460-43 | 43x17x13,5 | ●    |

3 glasses lt. 2 with airtight cover.  
3 vasi lt. 2 con coperchio ermetico.



**Jam bar**

Espositore marmellate  
Konfitürenständer  
Présentoir à confitures  
Expositor de mermeladas

| art.     | dim. cm.   | ml.   |
|----------|------------|-------|
| 41206-05 | 34,5x9x8,5 | 3x176 |



AY

**Cereal-bar**

Espositore per cereali  
Cerealien-Bar  
Présentoir à céréales  
Expositor de cereales

| art.     | dim. cm.   | lt. |
|----------|------------|-----|
| 41806-03 | 39,5x12x26 | 3x1 |



AY

**Cereal pitcher**

Caraffa cereali  
Cerealienkaraffe  
Pichet à céréales  
Jarra de cereales

| art.     | Ø cm. | dim. cm. | lt. |
|----------|-------|----------|-----|
| 41806-00 | 9     | 25,5     | 1   |



SAN

SS

**Cereal dispenser**

Distributore di cereali  
Müslispender  
Distributeur à céréales  
Dispensador de cereales

| art.     | dim. cm.   | lt. |
|----------|------------|-----|
| 41810-04 | 22x17,5x52 | 4,5 |







SAN  
SS

**Cereal dispenser**

Distributore di cereali  
Müslispender  
Distributeur à céréales  
Dispensador de cereales

art. dim. cm. lt.  
41810-09 22x35x52 2x4,5



PC  
SS

**Cereal dispenser**

Distributore di cereali  
Müslispender  
Distributeur à céréales  
Dispensador de cereales

art. dim. cm. lt.  
41909-08 33x24x64 7



PC  
SS

**Cereal dispenser**

Distributore di cereali  
Müslispender  
Distributeur à céréales  
Dispensador de cereales

art. dim. cm. lt.  
41807-12 30,5x28,5x60,5 3x4



SS

**Juice dispenser**

Distributore di succhi  
Saftdispenser  
Distributeur à jus  
Dispensador de zumos

art. dim. cm. lt.  
41901-08 36x26x55 8



SS

**Juice dispenser duo**

Distributore di succhi duo  
Saftdispenser duo  
Distributeur à jus duo  
Dispensador de zumo, doble

art. dim. cm. lt.  
41901-16 36x54x55 2x8



SS

**Juice dispenser**

Distributore di succhi  
Saftdispenser  
Distributeur à jus  
Dispensador de zumos

art. dim. cm. lt.  
18353-17 22x35x56 7

With 1 cooling unit. – Con 1 eutettico.



SS

**Juice dispenser**

Distributore di succhi  
Saftdispenser  
Distributeur à jus  
Dispensador de zumos

art. dim. cm. lt.  
41800-05 33x22x52 5



SS

**Juice dispenser duo**

Distributore di succhi duo  
Saftdispenser duo  
Distributeur à jus duo  
Dispensador de zumo, doble

art. dim. cm. lt.  
41800-10 42,5x30,5x52 2x5



SS

**Milk dispenser**

Distributore di latte  
Milchkanne  
Distributeur à lait  
Dispensador de leche

art. dim. cm. lt.  
41801-05 33x22x50 5



W

**Cereal dispenser**

Distributore di cereali  
Cerealinenspender  
Distributeur à céréales  
Dispensador de cereales

| art.     | dim. cm.   | lt. | col. |
|----------|------------|-----|------|
| 42470-45 | 21x20x55,5 | 4,5 | ●    |
| 42460-45 | 21x20x55,5 | 4,5 | ●    |

Maple/Wenge. – Acero/Wengè.



W

**Juice dispenser**

Distributore di succhi  
Saftdispenser  
Distributeur à jus de fruit  
Dispensador de zumo

| art.     | dim. cm. | lt. |
|----------|----------|-----|
| 41808-04 | 16x24x35 | 4   |



W

**Juice dispenser**

Distributore di succhi  
Saftdispenser  
Distributeur à jus de fruit  
Dispensador de zumo

| art.     | dim. cm.   | lt. | col. |
|----------|------------|-----|------|
| 42470-74 | 31x20x42   | 4   | ●    |
| 42470-76 | 35,5x22x50 | 6   | ●    |

Maple. With 2 cooling units. elements, top and base. – Acero. Con 2 eutettici, coperchio e base.



W

**Juice dispenser**

Distributore di succhi  
Saftdispenser  
Distributeur à jus de fruit  
Dispensador de zumo

| art.     | dim. cm.   | lt. | col. |
|----------|------------|-----|------|
| 42460-74 | 31x20x42   | 4   | ●    |
| 42460-76 | 35,5x22x50 | 6   | ●    |

Wenge. With 2 cooling units. elements, top and base. – Wengè. Con 2 eutettici, coperchio e base.



W

SS

**Juice dispenser**

Distributore di succhi  
Saftdispenser  
Distributeur à jus  
Dispensador de zumos

| art.     | dim. cm. | lt. |
|----------|----------|-----|
| 41907-04 | 21x31x44 | 4   |
| 41907-06 | 23x35x52 | 6   |

Beechwood. With cooling units.  
Faggio. Con eutettici.



W

PR

SS

**Milk dispenser**

Distributore di latte  
Milchkanne  
Distributeur à lait  
Dispensador de leche

| art.     | dim. cm.   | lt. |
|----------|------------|-----|
| 41900-04 | 23x32x42   | 4   |
| 41900-10 | 27x38,5x45 | 10  |

Beechwood. With cooling units.  
Faggio. Con eutettici.



SS

PP

**Insulated dispenser**

Distributore termico  
Iso-Dispenser  
Distributeur isothermique  
Dispensador térmico

| art.     | Ø cm. | h. cm.  | lt. |
|----------|-------|---------|-----|
| 41904-10 | 24    | 42>46,5 | 9,5 |



SS

**Air pot**

Caraffa termica  
Thermopumpkanne  
Pot à air isothermique  
Jarra térmica

| art.     | lt. |
|----------|-----|
| 42406-35 | 3,5 |
| 42406-40 | 4,0 |



SS

**Air pot**

Caraffa termica  
Thermopumpkanne  
Pot à air isothermique  
Jarra térmica

| art.     | lt. |
|----------|-----|
| 42400-19 | 1,9 |
| 42400-25 | 2,5 |
| 42400-30 | 3,0 |



# SERIES 12300

BUFFET LIVE COOKING

INDUCTION  
READY!



Paderno serie 2300 3-ply is especially designed for use in front of house and live cooking stations. Features super heat-conductive multi-layer construction that distributes heat from bottom to rim quickly and evenly. An attractive, multifunctional and colored line available in white, yellow, green, blue and orange. External finish with special heat-resistant paint (Whitford technology). Ideal for all types of cooking including induction. The lid equipped with a steam release device can be hooked to the side of the pan.

La serie Paderno 2300 3-ply è concepita per l'uso "front of house" e per le "live cooking stations". Costruita in materiale multistrato, assicura una distribuzione rapida ed uniforme del calore su tutta la superficie dell'utensile. Una linea attrattiva, multifunzionale e colorata disponibile nelle varianti bianco, giallo, verde, blu e arancio. Finitura esterna con speciale vernice (tecnologia Whitford) resistente al calore. Ideali per ogni tipo di cottura inclusa l'induzione. Il coperchio dotato di dispositivo di rilascio del vapore, può essere agganciato a lato della casseruola





**Stew pan with lid**

Casseruola con coperchio  
Brattpf mit Deckel  
Sautoir avec couvercle  
Sartén con tapa

| art.     | Ø cm. | h. cm. | lt. |
|----------|-------|--------|-----|
| 12303W16 | 16    | 8      | 1,6 |
| 12303W20 | 20    | 10     | 3,1 |
| 12303W24 | 24    | 12     | 5,4 |



**Stew pan with lid**

Casseruola con coperchio  
Brattpf mit Deckel  
Sautoir avec couvercle  
Sartén con tapa

| art.     | Ø cm. | h. cm. | lt. |
|----------|-------|--------|-----|
| 12303Y16 | 16    | 8      | 1,6 |
| 12303Y20 | 20    | 10     | 3,1 |
| 12303Y24 | 24    | 12     | 5,4 |



**Stew pan with lid**

Casseruola con coperchio  
Brattpf mit Deckel  
Sautoir avec couvercle  
Sartén con tapa

| art.     | Ø cm. | h. cm. | lt. |
|----------|-------|--------|-----|
| 12303G16 | 16    | 8      | 1,6 |
| 12303G20 | 20    | 10     | 3,1 |
| 12303G24 | 24    | 12     | 5,4 |



**Stew pan with lid**

Casseruola con coperchio  
Brattpf mit Deckel  
Sautoir avec couvercle  
Sartén con tapa

| art.     | Ø cm. | h. cm. | lt. |
|----------|-------|--------|-----|
| 12303B16 | 16    | 8      | 1,6 |
| 12303B20 | 20    | 10     | 3,1 |
| 12303B24 | 24    | 12     | 5,4 |



**Stew pan with lid**

Casseruola con coperchio  
Brattpf mit Deckel  
Sautoir avec couvercle  
Sartén con tapa

| art.     | Ø cm. | h. cm. | lt. |
|----------|-------|--------|-----|
| 12303O16 | 16    | 8      | 1,6 |
| 12303O20 | 20    | 10     | 3,1 |
| 12303O24 | 24    | 12     | 5,4 |



**Roasting pan with lid**

Casseruola carrè con coperchio  
Bräter mit Deckel  
Rôtissoire avec couvercle  
Asadera con tapa

| art.     | dim. cm. | h. cm. | lt. |
|----------|----------|--------|-----|
| 12304W26 | 27x27    | 7      | 4   |



**Roasting pan with lid**

Casseruola carrè con coperchio  
Bräter mit Deckel  
Rôtissoire avec couvercle  
Asadera con tapa

| art.     | dim. cm. | h. cm. | lt. |
|----------|----------|--------|-----|
| 12304Y26 | 27x27    | 7      | 4   |



**Roasting pan with lid**

Casseruola carrè con coperchio  
Bräter mit Deckel  
Rôtissoire avec couvercle  
Asadera con tapa

| art.     | dim. cm. | h. cm. | lt. |
|----------|----------|--------|-----|
| 12304G26 | 27x27    | 7      | 4   |



**Roasting pan with lid**

Casseruola carrè con coperchio  
Bräter mit Deckel  
Rôtissoire avec couvercle  
Asadera con tapa

| art.     | dim. cm. | h. cm. | lt. |
|----------|----------|--------|-----|
| 12304B26 | 27x27    | 7      | 4   |



**Roasting pan with lid**

Casseruola carrè con coperchio  
Bräter mit Deckel  
Rôtissoire avec couvercle  
Asadera con tapa

| art.     | dim. cm. | h. cm. | lt. |
|----------|----------|--------|-----|
| 12304O26 | 27x27    | 7      | 4   |







**NEW**

**Induction station**  
Set induzione  
Induktionsstation  
Station d'induction  
Estación inducción

| art.     | Ø cm. | dim. cm.  | h. cm. | V       | W   |
|----------|-------|-----------|--------|---------|-----|
| 49999-04 | 24    | 35,4x32,5 | 19     | 220-240 | 900 |

**Induction plate with temperature regulator 60>140°C. Black metal support, walnut wood insert and stainless steel frame.** – Piastra a induzione con regolatore di temperatura 60>140°C. Supporto in metallo nero, inserto in legno di noce e cornice inox.



**Bowl double wall**  
Ciotola doppia parete  
Schüssel, doppelwandig  
Bol à double paroi  
Tazón doble pared

| art.     | Ø cm. | h. cm. |
|----------|-------|--------|
| 12300-18 | 18    | 14,0   |
| 12300-24 | 24    | 18,2   |



**Bowl double wall**  
Ciotola doppia parete  
Schüssel, doppelwandig  
Bol à double paroi  
Tazón doble pared

| art.     | Ø cm. | h. cm. |
|----------|-------|--------|
| 12300W18 | 18    | 14,0   |
| 12300W24 | 24    | 18,2   |



**Bowl double wall**  
Ciotola doppia parete  
Schüssel, doppelwandig  
Bol à double paroi  
Tazón doble pared

| art.     | Ø cm. | h. cm. |
|----------|-------|--------|
| 12300Y18 | 18    | 14,0   |
| 12300Y24 | 24    | 18,2   |



**Bowl double wall**  
Ciotola doppia parete  
Schüssel, doppelwandig  
Bol à double paroi  
Tazón doble pared

| art.     | Ø cm. | h. cm. |
|----------|-------|--------|
| 12300G18 | 18    | 14,0   |
| 12300G24 | 24    | 18,2   |



**Bowl double wall**  
Ciotola doppia parete  
Schüssel, doppelwandig  
Bol à double paroi  
Tazón doble pared

| art.     | Ø cm. | h. cm. |
|----------|-------|--------|
| 12300B18 | 18    | 14,0   |
| 12300B24 | 24    | 18,2   |



**Bowl double wall**  
Ciotola doppia parete  
Schüssel, doppelwandig  
Bol à double paroi  
Tazón doble pared

| art.     | Ø cm. | h. cm. |
|----------|-------|--------|
| 12300O18 | 18    | 14,0   |
| 12300O24 | 24    | 18,2   |



# ATLANTIC BUFFET SYSTEM

BUFFET & PRESENTATION



Conceived and designed in the round and rectangular versions with different opening systems to meet any need ABS Atlantic Buffet System chafing dishes combine contemporary flexibility and functionality. All the parts of these simple-shaped, stackable, 100% stainless steel hygienic items can be easily taken apart for thorough cleaning.

The line comes from the expertise that only Sambonet Paderno can offer to top catering services. The lid is equipped with a new, transparent window made of unbreakable glass that lets you see the delicacies held in the chafing dishes. The gradual closing mechanism and the special lid removal method make the whole System even more effective.

Pensati e ideati nelle versioni rotonde, rettangolari con aperture differenziate per soddisfare ogni esigenza, gli scaldavivande ABS Atlantic Buffet System interpretano la funzionalità e la flessibilità contemporanea. Semplici nella forma, impilabili, igienici poiché realizzati in acciaio inox, facilmente smontabili in tutte le loro parti per una pulizia impeccabile, gli elementi appartenenti alla linea nascono dall'expertise che solo Sambonet Paderno è in grado di garantire alla ristorazione d'eccellenza. Grazie alla trasparenza del nuovo oblò in vetro temperato, i coperchi offrono visibilità alla prelibatezza dei contenuti degli scaldavivande. Il meccanismo di chiusura graduale e lo speciale metodo di rimozione dei coperchi rende ancora più performante l'intero Sistema.

## ATLANTIC TOP UNITS - DA APPOGGIO



### TOP UNIT - Chafing dish round

Scaldavivande tondo  
Chafing Dish, rund  
Chafing dish rond  
Chafing dish redondo

| art.     | Ø cm. | h. cm. | lt. |
|----------|-------|--------|-----|
| 18176-30 | 30    | 15     | 2,8 |
| 18176-36 | 36    | 15     | 5,0 |
| 18176-40 | 40    | 17     | 7,8 |



### TOP UNIT - Chafing dish round

Scaldavivande tondo  
Chafing Dish, rund  
Chafing dish rond  
Chafing dish redondo

| art.     | Ø cm. | h. cm. | lt. |
|----------|-------|--------|-----|
| 18176I30 | 30    | 15     | 2,8 |
| 18176I36 | 36    | 15     | 5,0 |
| 18176I40 | 40    | 17     | 7,8 |



### TOP UNIT - Chafing dish round

Scaldavivande tondo  
Chafing Dish, rund  
Chafing dish rond  
Chafing dish redondo

| art.     | Ø cm. | h. cm. | lt. |
|----------|-------|--------|-----|
| 18166-24 | 24    | 15     | 2,0 |
| 18166-30 | 30    | 15     | 2,8 |
| 18166-36 | 36    | 15     | 5,0 |
| 18166-40 | 40    | 17     | 7,8 |



### TOP UNIT - Chafing dish round

Scaldavivande tondo  
Chafing Dish, rund  
Chafing dish rond  
Chafing dish redondo

| art.     | Ø cm. | h. cm. | lt. |
|----------|-------|--------|-----|
| 18166I30 | 30    | 15     | 2,8 |
| 18166I36 | 36    | 15     | 5,0 |
| 18166I40 | 40    | 17     | 7,8 |



### TOP UNIT - Chafing dish rectangular

Scaldavivande rettangolare  
Chafing Dish, rechteckig  
Chafing dish rectangulaire  
Chafing dish rectangular

| art.     | dim. cm. | lt. |
|----------|----------|-----|
| 18172-54 | 57x47x18 | 10  |

**Long side opening.** – Apertura lato lungo.



### TOP UNIT - Chafing dish rectangular

Scaldavivande rettangolare  
Chafing Dish, rechteckig  
Chafing dish rectangulaire  
Chafing dish rectangular

| art.     | dim. cm.     | lt. |
|----------|--------------|-----|
| 18172-56 | 68,5x35,5x18 | 10  |

**Short side opening.** – Apertura lato corto.



**TOP UNIT - Chafing dish rectangular**

Scaldavivande rettangolare  
 Chafing Dish, rechteckig  
 Chafing dish rectangulaire  
 Chafing dish rectangular

| art.     | dim. cm. | lt. |
|----------|----------|-----|
| 18162-54 | 57x47x18 | 10  |

**Long side opening.** – Apertura lato lungo.**TOP UNIT - Chafing dish rectangular**

Scaldavivande rettangolare  
 Chafing Dish, rechteckig  
 Chafing dish rectangulaire  
 Chafing dish rectangular

| art.     | dim. cm.     | lt. |
|----------|--------------|-----|
| 18162-56 | 68,5x35,5x18 | 10  |

**Short side opening.** – Apertura lato corto.**ATLANTIC BUILT-IN UNITS - DA INCASSO****BUILT-IN UNIT - Chafing dish rectangular**

Scaldavivande rettangolare  
 Chafing Dish, rechteckig  
 Chafing dish rectangulaire  
 Chafing dish rectangular

| art.     | dim. cm. | lt. | std | V-W     |
|----------|----------|-----|-----|---------|
| 18162A55 | 57x47x18 | 10  |     |         |
| 18162E55 | 57x47x18 | 10  | EU  | 250-360 |
| 18162U55 | 57x47x18 | 10  | US  | 120-450 |

**Long side opening.** – Apertura lato lungo.

| art.     | dim. cm.     | lt. | std | V-W     |
|----------|--------------|-----|-----|---------|
| 18162A57 | 68,5x35,5x18 | 10  |     |         |
| 18162E57 | 68,5x35,5x18 | 10  | EU  | 250-360 |
| 18162U57 | 68,5x35,5x18 | 10  | US  | 120-450 |

**Short side opening.** – Apertura lato corto.

| art.     | dim. cm. | lt. | std | V-W     |
|----------|----------|-----|-----|---------|
| 18172A55 | 57x47x18 | 10  |     |         |
| 18172E55 | 57x47x18 | 10  | EU  | 250-360 |
| 18172U55 | 57x47x18 | 10  | US  | 120-450 |

**Long side opening.** – Apertura lato lungo.

| art.     | dim. cm.     | lt. | std | V-W     |
|----------|--------------|-----|-----|---------|
| 18172A57 | 68,5x35,5x18 | 10  |     |         |
| 18172E57 | 68,5x35,5x18 | 10  | EU  | 250-360 |
| 18172U57 | 68,5x35,5x18 | 10  | US  | 120-450 |

**Short side opening.** – Apertura lato corto.



**ATLANTIC ON STAND UNITS - CON SUPPORTO**



**Chafing dish, solid alcohol heating**  
Scaldavivande a combustibile solido  
Chafing Dish mit Brennstoff beheizt  
Chafing dish chauffage combustible solide  
Chafing dish calefacción combustible sólido

| art.     | Ø cm. | h. cm. | lt. |
|----------|-------|--------|-----|
| 18176A30 | 30    | 27     | 2,8 |
| 18176A36 | 36    | 27     | 5,0 |
| 18176A40 | 40    | 28     | 7,8 |



**Chafing dish, solid alcohol heating**  
Scaldavivande a combustibile solido  
Chafing Dish mit Brennstoff beheizt  
Chafing dish chauffage combustible solide  
Chafing dish calefacción combustible sólido

| art.     | Ø cm. | h. cm. | lt. |
|----------|-------|--------|-----|
| 18166A24 | 24    | 27     | 2,0 |
| 18166A30 | 30    | 27     | 2,8 |
| 18166A36 | 36    | 27     | 5,0 |
| 18166A40 | 40    | 28     | 7,8 |



**Chafing dish, electric heating**  
Scaldavivande, riscaldamento elettrico  
Chafing Dish, elektrisch beheizt  
Chafing dish chauffage électrique  
Chafing dish calefacción eléctrica

| art.     | Ø cm. | h. cm. | lt. | std | V-W     |
|----------|-------|--------|-----|-----|---------|
| 18176E30 | 30    | 27     | 2,8 | EU  | 250-190 |
| 18176E36 | 36    | 27     | 5,0 | EU  | 250-190 |
| 18176E40 | 40    | 28     | 7,8 | EU  | 250-190 |
| 18176U36 | 36    | 27     | 5,0 | US  | 120-240 |
| 18176U40 | 40    | 28     | 7,8 | US  | 120-240 |



**Chafing dish, electric heating**  
Scaldavivande, riscaldamento elettrico  
Chafing Dish, elektrisch beheizt  
Chafing dish chauffage électrique  
Chafing dish calefacción eléctrica

| art.     | Ø cm. | h. cm. | lt. | std | V-W     |
|----------|-------|--------|-----|-----|---------|
| 18166E24 | 24    | 27     | 2,0 | EU  | 250-80  |
| 18166E30 | 30    | 27     | 2,8 | EU  | 250-190 |
| 18166E36 | 36    | 27     | 5,0 | EU  | 250-190 |
| 18166E40 | 40    | 28     | 7,8 | EU  | 250-190 |
| 18166U24 | 24    | 27     | 2,0 | US  | 120-170 |
| 18166U36 | 36    | 27     | 5,0 | US  | 120-240 |
| 18166U40 | 40    | 28     | 7,8 | US  | 120-240 |



**Petite marmite**  
Petite marmite  
Petite marmite  
Petite marmite  
Petite marmite

| art.     | Ø cm. | h. cm. | lt. | std | V-W     |
|----------|-------|--------|-----|-----|---------|
| 18168A24 | 24    | 35     | 7   | -   | -       |
| 18168E24 | 24    | 35     | 7   | EU  | 250-80  |
| 18168U24 | 24    | 35     | 7   | US  | 120-170 |



**Chafing dish rectangular**

Scaldavivande rettangolare

Chafing Dish, rechteckig

Chafing dish rectangulaire

Chafing dish rectangular

| art.     | dim. cm.   | lt. | std | V-W     |
|----------|------------|-----|-----|---------|
| 18172A54 | 57x47x30,5 | 10  | -   | -       |
| 18172E54 | 57x47x30,5 | 10  | EU  | 250-360 |
| 18172U54 | 57x47x30,5 | 10  | US  | 120-450 |

**Long side opening.** – Apertura lato lungo.



**Chafing dish rectangular**

Scaldavivande rettangolare

Chafing Dish, rechteckig

Chafing dish rectangulaire

Chafing dish rectangular

| art.     | dim. cm.       | lt. | std | V-W     |
|----------|----------------|-----|-----|---------|
| 18172A56 | 68,5x35,5x30,5 | 10  | -   | -       |
| 18172E56 | 68,5x35,5x30,5 | 10  | EU  | 250-360 |
| 18172U56 | 68,5x35,5x30,5 | 10  | US  | 120-450 |

**Short side opening.** – Apertura lato corto.



**Chafing dish rectangular**

Scaldavivande rettangolare

Chafing Dish, rechteckig

Chafing dish rectangulaire

Chafing dish rectangular

| art.     | dim. cm.   | lt. | std | V-W     |
|----------|------------|-----|-----|---------|
| 18162A54 | 57x47x30,5 | 10  | -   | -       |
| 18162E54 | 57x47x30,5 | 10  | EU  | 250-360 |
| 18162U54 | 57x47x30,5 | 10  | US  | 120-450 |

**Long side opening.** – Apertura lato lungo.



**Chafing dish rectangular**

Scaldavivande rettangolare

Chafing Dish, rechteckig

Chafing dish rectangulaire

Chafing dish rectangular

| art.     | dim. cm.       | lt. | std | V-W     |
|----------|----------------|-----|-----|---------|
| 18162A56 | 68,5x35,5x30,5 | 10  | -   | -       |
| 18162E56 | 68,5x35,5x30,5 | 10  | EU  | 250-360 |
| 18162U56 | 68,5x35,5x30,5 | 10  | US  | 120-450 |

**Short side opening.** – Apertura lato corto.



**ASIA LINE**



**Chafing dish rectangular**

Scaldavivande rettangolare  
Chafing Dish, rechteckig  
Chafing dish rectangulaire  
Chafing dish rectangular



| art.     | dim. cm.   | lt. | std | V-W     |
|----------|------------|-----|-----|---------|
| 18132A54 | 67,5x44x42 | 10  | -   | -       |
| 18132E54 | 67,5x44x42 | 10  | EU  | 250-360 |
| 18132U54 | 67,5x44x42 | 10  | US  | 120-450 |

**Chafing dish, to be built in**

Scaldavivande da incasso  
Einbau Chafing Dish  
Chafing dish encastrable  
Chafing dish encastrable



| art.     | dim. cm.     | lt. | std | V-W     |
|----------|--------------|-----|-----|---------|
| 18132A55 | 67,5x44x34,5 | 10  | -   | -       |
| 18132E55 | 67,5x44x34,5 | 10  | EU  | 250-360 |
| 18132U55 | 67,5x44x34,5 | 10  | US  | 120-450 |

**Chafing dish round**

Scaldavivande tondo  
Chafing Dish, rund  
Chafing dish rond  
Chafing dish redondo



| art.     | Ø cm. | h. cm. | lt. | std | V-W     |
|----------|-------|--------|-----|-----|---------|
| 18136A33 | 33    | 44     | 3,5 | -   | -       |
| 18136E33 | 33    | 44     | 3,5 | EU  | 250-200 |
| 18136U33 | 33    | 44     | 3,5 | US  | 120-240 |
| 18136A40 | 40    | 58     | 6,0 | -   | -       |
| 18136E40 | 40    | 58     | 6,0 | EU  | 250-360 |
| 18136U40 | 40    | 58     | 6,0 | US  | 120-450 |

**Chafing dish round, to be built in**

Scaldavivande tondo da incasso

Chafing Dish, rund

Chafing dish rond encastrable

Chafing dish redondo encastrable

| art.     | Ø cm. | h. cm. | lt. | std | V-W     |
|----------|-------|--------|-----|-----|---------|
| 18136A34 | 33    | 34,5   | 3,5 | -   | -       |
| 18136E34 | 33    | 34,5   | 3,5 | EU  | 250-200 |
| 18136U34 | 33    | 34,5   | 3,5 | US  | 120-240 |
| 18136A41 | 40    | 43,0   | 6,0 | -   | -       |
| 18136E41 | 40    | 43,0   | 6,0 | EU  | 250-360 |
| 18136U41 | 40    | 43,0   | 6,0 | US  | 120-450 |

**Chafing dish rectangular**

Scaldavivande rettangolare

Chafing Dish, rechteckig

Chafing dish rectangulaire

Chafing dish rectangular

| art.     | dim. cm. | lt. | std | V-W     |
|----------|----------|-----|-----|---------|
| 18152A54 | 67x49x44 | 10  | -   | -       |
| 18152E54 | 67x49x44 | 10  | EU  | 250-360 |
| 18152U54 | 67x49x44 | 10  | US  | 120-450 |

**Chafing dish round**

Scaldavivande tondo

Chafing Dish, rund

Chafing dish rond

Chafing dish redondo

| art.     | Ø cm. | h. cm. | lt. | std | V-W     |
|----------|-------|--------|-----|-----|---------|
| 18156A33 | 33    | 47     | 3,5 | -   | -       |
| 18156E33 | 33    | 47     | 3,5 | EU  | 250-200 |
| 18156U33 | 33    | 47     | 3,5 | US  | 120-240 |
| 18156A40 | 40    | 61     | 6,0 | -   | -       |
| 18156E40 | 40    | 61     | 6,0 | EU  | 250-360 |
| 18156U40 | 40    | 61     | 6,0 | US  | 120-450 |

**Chafing dish rectangular**

Scaldavivande rettangolare

Chafing Dish, rechteckig

Chafing dish rectangulaire

Chafing dish rectangular

| art.     | dim. cm.   | lt. | std | V-W     |
|----------|------------|-----|-----|---------|
| 41690A11 | 63,5x35x32 | 8,5 | -   | -       |
| 41690E11 | 63,5x35x32 | 8,5 | EU  | 250-360 |
| 41690U11 | 63,5x35x32 | 8,5 | US  | 120-450 |

**Chafing dish rectangular**

Scaldavivande rettangolare

Chafing Dish, rechteckig

Chafing dish rectangulaire

Chafing dish rectangular

| art.     | dim. cm.   | lt. | std | V-W     |
|----------|------------|-----|-----|---------|
| 41691A11 | 71,5x52x45 | 8,5 | -   | -       |
| 41691E11 | 71,5x52x45 | 8,5 | EU  | 250-360 |
| 41691U11 | 71,5x52x45 | 8,5 | US  | 120-450 |







**Coffee urn**  
Scaldacaffè  
Kaffeedispenser  
Réchaud à café  
Calentador de café

| art.     | dim. cm.     | lt.  | std | V-W     |
|----------|--------------|------|-----|---------|
| 41903A10 | 31x33,5x54,5 | 10,5 | -   | -       |
| 41903E10 | 31x33,5x54,5 | 10,5 | EU  | 220-80  |
| 41903U10 | 31x33,5x54,5 | 10,5 | US  | 110-170 |



**Samovar**  
Pyramid

| art.     | dim. cm.     | lt. | Tea pot | std | V-W  |
|----------|--------------|-----|---------|-----|------|
| 49856-04 | 35,5x30x45,2 | 4   | Lt 1,2  | EU  | 2500 |

**Teapot with strainer. Cable length approx. 130 cm. With 2 heating elements 2000W and 500W.**  
Teiera con colino. Lunghezza cavo circa 130 cm. Con 2 resistenze 2000W e 500W.



**Samovar**  
2017

| art.     | dim. cm.     | lt. | Tea pot | std | V-W  |
|----------|--------------|-----|---------|-----|------|
| 49854-03 | 31x27,5x48,5 | 3   | Lt 1,2  | EU  | 1500 |

**Teapot with strainer, cable length approx. 130 cm. –** Teiera con colino. Lunghezza cavo circa 130 cm.



**Samovar**  
Romanov

| art.     | dim. cm. | lt. | Tea pot | std | V-W  |
|----------|----------|-----|---------|-----|------|
| 49855-05 | 34x27x59 | 5   | Lt 1,3  | EU  | 1800 |

**Teapot with strainer. Cable length approx. 100 cm. With 2 heating elements 1300W and 500W.**  
Teiera con colino. Lunghezza cavo circa 100 cm. Con 2 resistenze 1300W e 500W.



**Samovar**  
3006C

| art.     | dim. cm.     | lt. | Tea pot | std | V-W  |
|----------|--------------|-----|---------|-----|------|
| 49854-06 | 35,5x30x45,2 | 6   | Lt 1,5  | EU  | 2500 |

Teapot with strainer. With 2 heating elements 2000W and 500W. – Teiera con colino. Con 2 resistenze 2000W e 500W.



**Samovar**  
Soraya

| art.     | dim. cm.     | lt. | Tea pot | std | V-W  |
|----------|--------------|-----|---------|-----|------|
| 49855-10 | 35,2x44,5x69 | 10  | Lt 1,6  | EU  | 3000 |

Teapot with strainer. Cable length approx. 130 cm. With 2 heating elements 2300W and 700W.  
Teiera con colino. Lunghezza cavo circa 130 cm. Con 2 resistenze 2300W e 700W.



**Samovar**  
Katharina

| art.     | dim. cm.       | lt. | Tea pot | std | V-W  |
|----------|----------------|-----|---------|-----|------|
| 49855-15 | 39,5x44,5x74,5 | 15  | Lt 2,0  | EU  | 3000 |

Teapot with strainer. Cable length approx. 130 cm. With 2 heating elements 2300W and 700W.  
Teiera con colino. Lunghezza cavo circa 130 cm. Con 2 resistenze 2300W e 700W.



**Coffee percolator**  
Percolatore per caffè  
Kaffee-Perkolator  
Percolateur à café  
Percolator de café

| art.     | Ø cm. | h. cm. | lt. | std | V-W  |
|----------|-------|--------|-----|-----|------|
| 49846-05 | 28    | 38,5   | 4,5 | EU  | 950  |
| 49846-09 | 28    | 38,5   | 9,2 | EU  | 950  |
| 49846-15 | 33    | 54     | 15  | EU  | 1650 |





**Soup kettle**  
Zuppiera  
Suppenwärmer  
Marmite à soupe  
Olla de sopa

| art.     | Ø cm. | h. cm. | lt. | std | V-W         |
|----------|-------|--------|-----|-----|-------------|
| 49847-38 | 38    | 36,5   | 10  | EU  | 230-450/550 |



**Soup kettle**  
Zuppiera  
Suppenwärmer  
Marmite à soupe  
Olla de sopa

| art.     | Ø cm. | h. cm. | lt. | std | V-W     |
|----------|-------|--------|-----|-----|---------|
| 49847-08 | 33    | 37     | 10  | EU  | 230-400 |



**Soup kettle**  
Zuppiera  
Suppenkessel  
Marmite à soupe  
Olla de sopa

| art.     | Ø cm. | h. cm. | lt. |
|----------|-------|--------|-----|
| 49790-09 | 48    | 32     | 10  |





**Induction cooker, to be built into counter**

Piastra ad induzione, da incasso  
Induktionsplatte, thekeneinbau  
Plaque à induction, montage en comptoir  
Placa a inducción para emportar

| art.     | std | dim. cm.   |
|----------|-----|------------|
| 18162-RB | EU  | 36X38x12,5 |

**Schott ceran hob, timer (0-180 min.), 1-10 power levels, temperature range 60°C-240°C.**

Piano in vetroceramica Schott, timer 0-180 minuti, 1-10 livelli di potenza, temperatura 60-240°C.



**Induction cooker**

Piastra ad induzione  
Induktionsplatte  
Plaque à induction  
Placa a inducción

| art.     | std | dim. cm. |
|----------|-----|----------|
| 18162-RA | EU  | 30X37x10 |

**Stainless steel body, Schott ceran hob, led display, timer (0-180 min.), 1-10 power levels, temperature range 60°C-240°C.**

Corpo inox, piano in vetroceramica Schott, display a led, timer 0-180 minuti, 1-10 livelli di potenza, temperatura 60-240°C.



NEW

**Induction station**

Postazione induzione  
Induktionsstation  
Station d'induction  
Estación inducción

| art.     | std | dim. cm.         |
|----------|-----|------------------|
| 49999-04 | EU  | 35,4x32,5x19 900 |

**Induction plate with temperature regulator 60>140°C. Black metal support, walnut wood insert and stainless steel frame.**

Piastra a induzione con regolatore di temperatura 60>140°C. Supporto in metallo nero, inserto in legno di noce e cornice inox.



**Round stand**

Supporto rotondo  
Gestell, rund  
Support rond  
Soporte redondo

| art.     | Ø cm. |
|----------|-------|
| 18166-AA | 24    |
| 18166-AM | 30    |
| 18166-AB | 36    |
| 18166-AC | 40    |



**Rectangular stand**

Supporto rettangolare  
Gestell, rechteckig  
Support rectangulaire  
Soporte rectangular

| art.     | dim. cm. |
|----------|----------|
| 18162-AA | 57x47    |



**Soup tureen without lid**

Zuppiera senza coperchio  
Suppenschüssel ohne Deckel  
Soupière sans couvercle  
Sopera sin tapa

| art.     | Ø cm. | lt. |
|----------|-------|-----|
| 18168-GA | 24    | 7   |





**Round food pan, stainless steel**  
Portavivande tondo, inox  
Einsatzbehälter, rund, Edelstahl Rostfrei  
Bac rond, inox  
Baño-maria redondo, inox

| art.     | Ø cm. | h. cm. | lt. |
|----------|-------|--------|-----|
| 18136-EA | 33    | 6,0    | 3,5 |
| 18136-EB | 40    | 7,5    | 6,0 |

**For ASIA round chafing dishes.**  
Per scaldavivande ASIA tondi.



**Round food pan, stainless steel**  
Portavivande tondo, inox  
Einsatzbehälter, rund, Edelstahl Rostfrei  
Bac rond, inox  
Baño-maria redondo, inox

| art.     | Ø cm. |
|----------|-------|
| 18166-EG | 24    |
| 18166-EM | 30    |
| 18166-EH | 36    |
| 18166-EI | 40    |

**For ABS round chafing dishes.**  
Per scaldavivande ABS tondi.



**Round porcelain insert**  
Inserto tondo, porcellana  
Porzellaneinsatz, rund  
Bac rond, porcelaine  
Baño-maria redondo, porcelana

| art.     | Ø cm. | h. cm. |
|----------|-------|--------|
| 44352-30 | 33    | 5,7    |
| 44352-40 | 40    | 7,5    |

**For ASIA round chafing dishes.**  
Per scaldavivande ASIA tondi.



**Round porcelain insert, 2 food sections**  
Inserto tondo, porcellana, 2 scomparti  
Porzellaneinsatz 2-tlg., rund  
Bac rond, porcelaine, 2 compartements  
Baño-maria redondo, porcelana 2 compartimentos

| art.     | Ø cm. | h. cm. |
|----------|-------|--------|
| 44355-30 | 33    | 5,7    |
| 44355-40 | 40    | 7,5    |

**For ASIA round chafing dishes.**  
Per scaldavivande ASIA tondi.



**Round porcelain insert**  
Inserto tondo, porcellana  
Porzellaneinsatz, rund  
Bac rond, porcelaine  
Baño-maria redondo, porcelana

| art.     | Ø cm. |
|----------|-------|
| 18166-EL | 30    |
| 18166-EC | 36    |
| 18166-EB | 40    |

**For ABS round chafing dishes.**  
Per scaldavivande ABS tondi.



**Round porcelain insert, 2 food sections**  
Inserto tondo, porcellana, 2 scomparti  
Porzellaneinsatz 2-tlg., rund  
Bac rond, porcelaine, 2 compartements  
Baño-maria redondo, porcelana 2 compartimentos

| art.     | Ø cm. |
|----------|-------|
| 18166-ED | 36    |
| 18166-EJ | 40    |

**For ABS round chafing dishes.**  
Per scaldavivande ABS tondi.



**Food pan GN 1/1, stainless steel**  
Bacinella GN 1/1, inox  
GN-Behälter 1/1, Edelstahl Rostfrei  
Bac GN 1/1, inox  
Baño-maria GN 1/1, inox

| art.     | dim. cm.    |
|----------|-------------|
| 14102-04 | 53x32,5x4   |
| 14102-06 | 53x32,5x6,5 |



**Food pan GN 1/1, porcelain**  
Bacinella GN 1/1, porcellana  
GN-Behälter 1/1, Porzellan  
Bac GN 1/1, porcelaine  
Baño-maria GN 1/1, porcelana

| art.     | dim. cm.    |
|----------|-------------|
| 44332-03 | 53x32,5x2   |
| 44332-06 | 53x32,5x6,5 |



**Fuel Holder, stainless steel**  
Portacombustibile, inox  
Brennstoffhalterung, Edelstahl Rostfrei  
Porte Brûleur, inox  
Contenedor de combustible, inox

| art.     | Ø cm. | h. cm. |
|----------|-------|--------|
| 41809-09 | 9     | 6,5    |

**Suitable for chafing dishes items 41690 and 41691.** – Adatto per gli scaldavivande art. 41690 e 41691.



**Fuel Holder, stainless steel**  
Portacombustibile, inox  
Brennstoffhalterung, Edelstahl Rostfrei  
Porte Brûleur, inox  
Contenedor de combustible, inox

| art.     | Ø cm. | h. cm. |
|----------|-------|--------|
| 18132-FB | 10    | 7,5    |

**Suitable for chafing dishes items 18152 and 18156.** – Adatto per gli scaldavivande art. 18152 e 18156.



**Fuel Holder, stainless steel**  
Portacombustibile, inox  
Brennstoffhalterung, Edelstahl Rostfrei  
Porte Brûleur, inox  
Contenedor de combustible, inox

18136-KA

**Kit for ABS round ø cm 24-30-36.**  
Set per scaldavivande ABS ø cm 24-30-36.



**Fuel Holder, stainless steel**  
Portacombustibile, inox  
Brennstoffhalterung, Edelstahl Rostfrei  
Porte Brûleur, inox  
Contenedor de combustible, inox

18132-KA

**Kit for ABS rectangular and round ø cm 40.**  
Set per scaldavivande ABS rettangolari e ø cm 40.



**Jelly fuel**

Gel combustibile  
Brenngel  
Gel combustible  
Combustible gel

| art.     | lt. | gr. | U. Pack |
|----------|-----|-----|---------|
| 41695-15 | -   | 200 | 2       |
| 41695-10 | 1   | -   | -       |
| 41695-50 | 5   | -   | -       |
| 41695-90 | 10  | -   | -       |



**Thermoregulator**  
Termoregolatore  
Thermoregler  
Thermorégulateur  
Termorregulador

| art.     | std |
|----------|-----|
| 18132-AE | EU  |

**For rectangular and round units ø cm 30-33-36-40.** – Per scaldavivande rettangolari e tondi ø cm 30-33-36-40.



**Thermoregulator**  
Termoregolatore  
Thermoregler  
Thermorégulateur  
Termorregulador

| art.     | std |
|----------|-----|
| 18132-AU | US  |

**For rectangular and round units ø cm 30-33-36-40.** – Per scaldavivande rettangolari e tondi ø cm 30-33-36-40.



**Electric heating units**

Piastre elettriche  
Elektro-Heizelemente  
Corps de chauffe électriques  
Calentadores eléctricos

| art.     | std | V-W     |
|----------|-----|---------|
| 18136-KE | EU  | 220-200 |
| 18136-KU | US  | 110-240 |

**Cm. 20x20 - For ASIA round chafing dishes cm 33.** – Per scaldavivande ASIA tondo cm 33.



**Electric heating units**

Piastre elettriche  
Elektro-Heizelemente  
Corps de chauffe électriques  
Calentadores eléctricos

| art.     | std | V-W     |
|----------|-----|---------|
| 18166-KP | EU  | 220-180 |

**Cm. 20x21 - For ABS round ø cm 30.**  
Per scaldavivande ABS tondo ø cm 30.



**Electric heating units**

Piastre elettriche  
Elektro-Heizelemente  
Corps de chauffe électriques  
Calentadores eléctricos

| art.     | std | V-W     |
|----------|-----|---------|
| 18166-KE | EU  | 220-200 |
| 18166-KU | US  | 110-240 |

**Cm. 20x25 - For ABS round ø cm 36-40.**  
Per scaldavivande ABS tondo ø cm 36-40.



**Electric heating units**

Piastre elettriche  
Elektro-Heizelemente  
Corps de chauffe électriques  
Calentadores eléctricos

| art.     | std | V-W     |
|----------|-----|---------|
| 18132-KE | EU  | 220-380 |
| 18132-KU | US  | 110-450 |

**Cm. 20x25 - For ASIA rectangular and round chafing dishes cm 40.** – Per scaldavivande ASIA rettangolari e tondi cm 40.



**Electric heating units**

Piastre elettriche  
Elektro-Heizelemente  
Corps de chauffe électriques  
Calentadores eléctricos

| art.     | std | V-W     |
|----------|-----|---------|
| 18162-KE | EU  | 220-380 |
| 18162-KU | US  | 110-450 |

**Cm. 20x25 - For ABS rectangular.**  
Per scaldavivande ABS rettangolari.



**Electric heating units**

Piastre elettriche  
Elektro-Heizelemente  
Corps de chauffe électriques  
Calentadores eléctricos

| art.     | std | V-W     |
|----------|-----|---------|
| 18341-KE | EU  | 220-80  |
| 18341-KU | US  | 110-170 |

**Cm. Ø 13,5 - For ABS round ø cm 24.**  
Per scaldavivande ABS tondo ø cm 24.



# SERIES VERSAILLES

DINING ROOM TROLLEYS  
CARRELLI SALA



Main structure and tops in plywood with reinforced edges. Legs in beechwood. Standard finishing rosewood color. Other colors: walnut, mahogany and oak. Standard swivel casters in antistatic rubber, on request polyurethane casters. All trolleys are available equipped with rubber bumper.

Struttura portante, piani di servizio in legno multistrato con bordi massicci. Gambe in massello di faggio. Finitura standard tinta palissandro. Su richiesta colori: noce, mogano e rovere. Ruote standard in gomma antistatica, optional ruote in poliuretano. Tutti i carrelli possono essere dotati di profilo paraurti.





#### Roast beef/stew trolley

Carrello arrostiti/bolliti  
Rinderbrust-/Fleischgerichtewagen  
Chariot à rôtis  
Carro roast beef

| art.     | dim. cm.   | Kg. | V   | W   | color    | col. |
|----------|------------|-----|-----|-----|----------|------|
| 18874-11 | 126x62x109 | 54  | 120 | 600 | rosewood | ●    |
| 18874M11 | 126x62x109 | 54  | 120 | 600 | mahogany | ●    |
| 18874N11 | 126x62x109 | 54  | 120 | 600 | walnut   | ●    |
| 18874R11 | 126x62x109 | 54  | 120 | 600 | oak      | ●    |
| 18874-22 | 126x62x109 | 54  | 230 | 700 | rosewood | ●    |
| 18874M22 | 126x62x109 | 54  | 230 | 700 | mahogany | ●    |
| 18874N22 | 126x62x109 | 54  | 230 | 700 | walnut   | ●    |
| 18874R22 | 126x62x109 | 54  | 230 | 700 | oak      | ●    |

**18-10 s/s revolving top adjustable up to 180°, mirror polish finishing - 4 swivel casters, 2 with brakes, bain-marie tank with 3 GN 1/2 10 litres each - removable wilsonart cutting board mm 354x265 revolving plate rack and removable knife holder in 18-10 s/s - 2 taps for water discharge - 2 heating units 700W each - 1 built in plug, backside - 3 built-in plugs, deck downside - 2 pipe plugs - cable - 3 switches, (1 magneto-thermic).** – Cloche inox 18-10 lucido a specchio, apertura a scomparsa a 180° - 4 ruote pivotanti, 2 con freno – vasca bagnomaria con 3 portavivande GN 1/2 da lt 10 cad. - tagliere mobile in wilsonart, mm 354x265 - portapiatti ribaltabile e portacoltelli estraibile in acciaio inox 18-10 - 2 rubinetti di scarico a sfera - 2 piastre elettriche da 700W cad. - 1 spina ad incasso (posteriore carrello) - 3 prese ad incasso (sotto piano carrello) - 2 spine a pipa - cavo di alimentazione - 3 interruttori di cui 1 magnetotermico.



#### Flambé trolley

Carrello flambé  
Flambierwagen  
Chariot à flamber  
Carro flambé

| art.     | dim. cm.      | Kg.  | color    | col. |
|----------|---------------|------|----------|------|
| 18876-00 | 122x58,5x89,5 | 44,5 | rosewood | ●    |
| 18876M00 | 122x58,5x89,5 | 44,5 | mahogany | ●    |
| 18876N00 | 122x58,5x89,5 | 44,5 | walnut   | ●    |
| 18876R00 | 122x58,5x89,5 | 44,5 | oak      | ●    |

**4 swivel casters, 2 with brakes - upper deck in 18-10 stainless steel mm 540x1042 with bottle holder protection ring - 2 lower wooden decks - cabinet for gas cylinder - gas/burning/lighting unit - piezoelectric lighting device - operating with liquid butan gas, 2,75 kg rechargeable cylinder (lasting for 20 hours about) or 1,8 kg cylinder - trolley supplied without cylinder.** – 4 ruote pivotanti di cui 2 con freno - pianale inox mm 540x1042 completo di barriera portabottiglie - 2 piani d'appoggio inferiori in legno - vano porta bombole con sportello di chiusura - gruppo gas/bruciatore/accenditore - dispositivo di accensione piezoelettrico - funzionamento a gas liquido butano in bombola ricaricabile da kg 2,75 (autonomia 20 ore circa) oppure da kg 1,8 - bombola NON fornita.



#### Standard gueridon trolley

Carrello gueridon, standard  
Gueridonwagen, Standard  
Chariot gueridon, standard  
Carro gueridon estándar

| art.     | dim. cm.     | Kg.  | color    | col. |
|----------|--------------|------|----------|------|
| 18886-00 | 77,5x51x74,5 | 14,5 | rosewood | ●    |
| 18886M00 | 77,5x51x74,5 | 14,5 | mahogany | ●    |
| 18886N00 | 77,5x51x74,5 | 14,5 | walnut   | ●    |
| 18886R00 | 77,5x51x74,5 | 14,5 | oak      | ●    |

**4 swivel casters without brakes. Upon request, the trolley can be supplied equipped with intermediate shelf.** – 4 ruote pivotanti, senza freno. Su richiesta è possibile fornire il carrello dotato di piano intermedio.



#### De luxe gueridon trolley

Carrello gueridon, de luxe  
Gueridonwagen, Luxus-Ausführung  
Chariot gueridon, de luxe  
Carro gueridon, de luxe

| art.     | dim. cm.     | Kg.  | color    | col. |
|----------|--------------|------|----------|------|
| 18887-00 | 77,5x51x74,5 | 16,5 | rosewood | ●    |
| 18887M00 | 77,5x51x74,5 | 16,5 | mahogany | ●    |
| 18887N00 | 77,5x51x74,5 | 16,5 | walnut   | ●    |
| 18887R00 | 77,5x51x74,5 | 16,5 | oak      | ●    |

**4 swivel casters without brakes - 6 compartments drawer - removable upper deck.** – 4 ruote pivotanti, senza freno - cassetteria a sei scomparti - piano d'appoggio estraibile.





**Flambé trolley, electric**

Carrello flambé, elettrico  
Flambierwagen, elektrisch  
Chariot à flamber, électrique  
Carro flambé, eléctrico

| art.     | dim. cm.      | Kg.  | V   | W    | color    | col. |
|----------|---------------|------|-----|------|----------|------|
| 18876-01 | 122x58,5x89,5 | 44,5 | 230 | 2300 | rosewood | ●    |
| 18876M01 | 122x58,5x89,5 | 44,5 | 230 | 2300 | mahogany | ●    |
| 18876N01 | 122x58,5x89,5 | 44,5 | 230 | 2300 | walnut   | ●    |
| 18876R01 | 122x58,5x89,5 | 44,5 | 230 | 2300 | oak      | ●    |

**4 swivel casters, 2 with brakes – upper deck in 18-10 stainless steel mm 540x1042 with protection ring – 2 lower wooden decks - built-in electric heating unit, high-light, ø 32 cm, ceramic heating surface ø 26 cm - 1 built-in plug, backside - cable - adjustable heat control unit and 1 magneto termic switch.** – 4 ruote pivotanti di cui 2 con freno - pianale inox mm 540x1042 completo di barriera perimetrale - 2 piani d'appoggio inferiori in legno - piastra elettrica high-light da incasso ø 32 cm, piano riscaldante in vetroceramica ø 26 cm - 1 spina ad incasso (posteriore carrello) - cavo di alimentazione - regolatore di energia ed interruttore magnetotermico.



**Flambé trolley, 2 burners**

Carrello flambé, 2 fuochi  
Flambierwagen, 2 Brenner  
Chariot à flamber, 2 feux  
Carro flambé, 2 fuegos

| art.     | dim. cm.      | Kg.  | color    | col. |
|----------|---------------|------|----------|------|
| 18877-00 | 122x58,5x89,5 | 46,5 | rosewood | ●    |
| 18877M00 | 122x58,5x89,5 | 46,5 | mahogany | ●    |
| 18877N00 | 122x58,5x89,5 | 46,5 | walnut   | ●    |
| 18877R00 | 122x58,5x89,5 | 46,5 | oak      | ●    |

**4 swivel casters, 2 with brakes - upper deck in 18-10 stainless steel mm 540x1042 with protection ring - 2 lower wooden decks - cabinet for gas cylinder – 2 gas/burning/lighting units - piezoelectric lighting device - operating with liquid butan gas, 2,75 kg rechargeable cylinder (lasting for 20 hours about) or 1,8 kg cylinder - trolley supplied without cylinder.** – 4 ruote pivotanti di cui 2 con freno - pianale inox mm 540x1042 completo di barriera perimetrale – 2 piani d'appoggio inferiori in legno - vano porta bombole con sportello di chiusura- 2 gruppi gas/bruciatore/accenditore - dispositivo di accensione piezoelettrico - funzionamento a gas liquido butano in bombola ricaricabile da kg 2,75 (autonomia 20 ore circa) oppure da kg 1,8 - bombola NON fornita.



**Mini flambé trolley**

Carrello mini-flambé  
Flambierwagen, Mini-Ausführung  
Chariot à flamber, mini  
Mini carro flambé

| art.     | dim. cm.     | Kg. | color    | col. |
|----------|--------------|-----|----------|------|
| 18875-00 | 77,5x51x74,5 | 22  | rosewood | ●    |
| 18875M00 | 77,5x51x74,5 | 22  | mahogany | ●    |
| 18875N00 | 77,5x51x74,5 | 22  | walnut   | ●    |
| 18875R00 | 77,5x51x74,5 | 22  | oak      | ●    |

**4 swivel casters without brakes - upper deck in 18-10 stainless steel, satin finishing - lower deck with bottle holder.** – 4 ruote pivotanti, senza freno - piano superiore in acciaio inox 18-10, satinato - vano inferiore con portabottiglie.



**Hors d'oeuvre trolley**

Carrello antipasti  
Vorspeisewagen  
Chariot à hors d'oeuvres  
Carro entremeses

| art.     | dim. cm.   | Kg. | color    | col. |
|----------|------------|-----|----------|------|
| 18878-00 | 122x62x106 | 38  | rosewood | ●    |
| 18878M00 | 122x62x106 | 38  | mahogany | ●    |
| 18878N00 | 122x62x106 | 38  | walnut   | ●    |
| 18878R00 | 122x62x106 | 38  | oak      | ●    |

**4 swivel casters, 2 with brakes – methacrylate revolving cloche – hors d'oeuvre inserts carrying deck in 18-10 s/s with protection ring - 9 hors d'oeuvre glass inserts, mm 123x203. Upon request, the trolley can be supplied equipped with intermediate shelf.** – 4 ruote pivotanti, 2 con freno - cupola in metacrilato con apertura a scomparsa - piano porta-vaschette antipasti in acciaio inox 18-10 con barriera perimetrale - 9 vaschette antipasti in vetro, dim. mm 123 x 203. Su richiesta è possibile fornire il carrello dotato di piano intermedio.



**Cooled hors d'oeuvre trolley**

Carrello antipasti, refrigerato  
Vorspeisewagen, gekühlt  
Chariot à hors d'oeuvres, réfrigéré  
Carro entremeses, refrigerado

| art.     | dim. cm.   | Kg. | color    | col. |
|----------|------------|-----|----------|------|
| 18879-00 | 122x62x106 | 38  | rosewood | ●    |
| 18879M00 | 122x62x106 | 38  | mahogany | ●    |
| 18879N00 | 122x62x106 | 38  | walnut   | ●    |
| 18879R00 | 122x62x106 | 38  | oak      | ●    |

**4 swivel casters, 2 with brakes - methacrylate revolving cloche – eutectic pads container with 18-10 stainless steel cover - 8 eutectic pads 2,2 lbs each, mm 170x200 - 9 hors d'oeuvre glass inserts, mm 123x203. Upon request, the trolley can be supplied equipped with intermediate shelf. – 4 ruote pivotanti di cui 2 con freno - cupola in metacrilato, con apertura a scomparsa - copertura vasca per contenitori eutettici in acciaio inox 18-10 - 8 contenitori eutettici da kg 1 cadauno, dim. mm 170 x 200 - 9 vaschette antipasti in vetro, dim. mm 123 x 203. Su richiesta è possibile fornire il carrello dotato di piano intermedio.**



**Patisserie trolley**

Carrello pasticceria Omicron  
Kuchen-/Nachspeisewagen  
Chariot à pâtisserie  
Carro postres

| art.     | dim. cm.     | Kg. | color    | col. |
|----------|--------------|-----|----------|------|
| 18880-00 | 113x56,5x104 | 57  | rosewood | ●    |
| 18880M00 | 113x56,5x104 | 57  | mahogany | ●    |
| 18880N00 | 113x56,5x104 | 57  | walnut   | ●    |
| 18880R00 | 113x56,5x104 | 57  | oak      | ●    |

**Methacrylate revolving cloche, bifrontal rotation – 4 swivel casters, 2 with brakes - 1 upper fixed deck in metacrilat mm 200x750 - 1 upper removable deck in metacrilat mm 400x750 – 2 revolving plate racks in 18-10 stainless steel - 2 lower wooden decks. – Cupola tonda in metacrilato, montata su guide laterali, che ne permettono la rotazione nei due sensi - 4 ruote pivotanti di cui 2 con freno - 1 piano fisso in metacrilato mm 200x750 - 1 piano mobile in metacrilato mm 400x750 - 2 portapiatti ribaltabili in acciaio inox 18-10 - 2 piani d'appoggio inferiori in legno.**



**Cake and cheese trolley**

Carrello dolci-formaggi  
Dessert-/Käsewagen  
Chariot à fromages et desserts  
Carro postres/quesos

| art.     | dim. cm.   | Kg. | color    | col. |
|----------|------------|-----|----------|------|
| 18882-00 | 122x62x106 | 38  | rosewood | ●    |
| 18882M00 | 122x62x106 | 38  | mahogany | ●    |
| 18882N00 | 122x62x106 | 38  | walnut   | ●    |
| 18882R00 | 122x62x106 | 38  | oak      | ●    |

**4 swivel casters, 2 with brakes - methacrylate revolving cloche - beech texwood cutting board mm 728x424 - revolving plate rack in 18-10 stainless steel. Upon request, the trolley can be supplied equipped with intermediate shelf. – 4 ruote pivotanti di cui 2 con freno - cupola in metacrilato, con apertura a scomparsa - tagliere in texwood faggio naturale mm 728 x 424 - portapiatti ribaltabile in acciaio inox 18-10. Su richiesta è possibile fornire il carrello dotato di piano intermedio.**



**Cooled cake trolley**

Carrello dolci, refrigerato  
Dessertwagen, gekühlt  
Chariot à desserts, réfrigéré  
Carro postres, refrigerado

| art.     | dim. cm.   | Kg.  | color    | col. |
|----------|------------|------|----------|------|
| 18884-00 | 122x62x106 | 47,5 | rosewood | ●    |
| 18884M00 | 122x62x106 | 47,5 | mahogany | ●    |
| 18884N00 | 122x62x106 | 47,5 | walnut   | ●    |
| 18884R00 | 122x62x106 | 47,5 | oak      | ●    |

**4 swivel casters, 2 with brakes - metacrilat revolving cloche – eutectic pads container with 18-10 stainless steel cover - 8 eutectic pads 2,2 lbs each, mm 170x200 - revolving plate rack in 18-10 stainless steel. Upon request, the trolley can be supplied equipped with intermediate shelf. – 4 ruote pivotanti di cui 2 con freno - cupola in metacrilato, con apertura a scomparsa - vaschetta porta contenitori eutettici con copertura in acciaio inox 18-10 - 8 contenitori eutettici da kg 1 cadauno, mm 170x200 - portapiatti ribaltabile in acciaio inox 18-10. Su richiesta è possibile fornire il carrello dotato di piano intermedio.**





**Cooled mini cheese trolley**

Carrello mini-formaggi, refrigerato  
Käsewagen, gekühlt, Mini-Ausführung  
Chariot à fromages, réfrigéré, mini  
Mini carro quesos, refrigerado

| art.     | dim. cm.   | Kg.  | color    | col. |
|----------|------------|------|----------|------|
| 18895-00 | 77,5x51x94 | 16,5 | rosewood | ●    |
| 18895M00 | 77,5x51x94 | 16,5 | mahogany | ●    |
| 18895N00 | 77,5x51x94 | 16,5 | walnut   | ●    |
| 18895R00 | 77,5x51x94 | 16,5 | oak      | ●    |

**4 swivel casters without brakes - metacrilat roll-top cover, opening at 90° - eutectic pads container with stainless steel cover (eutectic pads incl.) - 1 removable cutting board, GN 1/1 - revolving plate rack in stainless steel. - 4 ruote pivotanti senza freno - cupola in metacrilato, con apertura a 90° - vaschetta porta contenitori eutettici (eutettici inclusi) con copertura in acciaio inox - 1 tagliere mobile, GN 1/1 - portapiatti ribaltabile in acciaio inox.**



**Wine trolley**

Carrello vini  
Weinwagen  
Chariot à vins  
Carro de vinos

| art.     | dim. cm.  | Kg. | color    | col. |
|----------|-----------|-----|----------|------|
| 18897-00 | 122x62x92 | 39  | rosewood | ●    |
| 18897M00 | 122x62x92 | 39  | mahogany | ●    |
| 18897N00 | 122x62x92 | 39  | walnut   | ●    |
| 18897R00 | 122x62x92 | 39  | oak      | ●    |

**4 swivel casters, 2 with brakes - upper deck with stainless steel bottle holder ring - bottle caps and wine card compartment - 6 compartments for bottle coolers (bottle coolers included) - glass rack, deck downside - lower deck with bottle rack, 12 compartments. - 4 ruote pivotanti di cui 2 con freno - barriera porta bottiglie in acciaio inox - contenitore per tappi e carta vini - vano con 6 glacette (glacette incluse) - rastrelliera porta bicchieri, sotto piano carrello - piano inferiore con rastrelliera porta bottiglie, 12 posti.**



**Liqueur trolley**

Carrello liquori  
Aperitif-/Digestivwagen  
Chariot à liqueurs  
Carro licores

| art.     | dim. cm.     | Kg. | color    | col. |
|----------|--------------|-----|----------|------|
| 18889-00 | 124x68,5x104 | 37  | rosewood | ●    |
| 18889M00 | 124x68,5x104 | 37  | mahogany | ●    |
| 18889N00 | 124x68,5x104 | 37  | walnut   | ●    |
| 18889R00 | 124x68,5x104 | 37  | oak      | ●    |

**4 swivel casters, 2 with brakes - bottle holder protection ring in 18-10 stainless steel. - 4 ruote pivotanti di cui 2 con freno - barriera portabottiglie in acciaio inox 18-10.**



**Serving trolley**

Carrello servizio  
Servierwagen  
Chariot à servir  
Carro de servicio

| art.     | dim. cm.      | Kg.  | color    | col. |
|----------|---------------|------|----------|------|
| 18891-00 | 122x58,5x89,5 | 35,5 | rosewood | ●    |
| 18891M00 | 122x58,5x89,5 | 35,5 | mahogany | ●    |
| 18891N00 | 122x58,5x89,5 | 35,5 | walnut   | ●    |
| 18891R00 | 122x58,5x89,5 | 35,5 | oak      | ●    |

**4 swivel casters, 2 with brakes - removable upper deck and wooden drawer. Upon request, the trolley can be supplied equipped with intermediate shelf. - 4 ruote pivotanti di cui 2 con freno - piano estraibile e cassetto in legno. Su richiesta è possibile fornire il carrello dotato di piano intermedio.**



**Sherbet/ice cream trolley**

Carrello sorbetti  
Sorbetwagen  
Chariot à sorbets/glacés  
Carro sorbetes

| art.     | dim. cm.  | Kg. | color    | col. |
|----------|-----------|-----|----------|------|
| 18893-00 | 122x62x93 | 43  | rosewood | ●    |
| 18893M00 | 122x62x93 | 43  | mahogany | ●    |
| 18893N00 | 122x62x93 | 43  | walnut   | ●    |
| 18893R00 | 122x62x93 | 43  | oak      | ●    |

**4 swivel casters, 2 with brakes - 4 18-10 stainless steel insulated sherbet holders (lt 1,2 each) - flatware drawer - revolving plate rack and ice cream scoops holder in stainless steel.** – 4 ruote pivotanti di cui 2 con freno - 4 sorbettiere termiche in acciaio inox 18-10 da lt 1,2 cadauna - cassetto portaposate - portapiatti ribaltabile e portapalette-gelato in acciaio inox 18-10.



**Round trolley**

Carrello tondo  
Servierwagen, rund  
Chariot rond  
Carro redondo

| art.     | Ø cm. | h. cm. | Kg. | color    | col. |
|----------|-------|--------|-----|----------|------|
| 18888-00 | 60    | 89,5   | 23  | rosewood | ●    |
| 18888M00 | 60    | 89,5   | 23  | mahogany | ●    |
| 18888N00 | 60    | 89,5   | 23  | walnut   | ●    |
| 18888R00 | 60    | 89,5   | 23  | oak      | ●    |

**4 swivel casters without brakes – removable upper deck - perimeter barrier.**  
4 ruote pivotanti, senza freno - piano d'appoggio laterale estraibile - barriera perimetrale.



PP

**Serving trolley**

Carrello servizio  
Servierwagen  
Chariot à servir  
Carro de servicio

| art.     | dim. cm. | col. |
|----------|----------|------|
| 49995-04 | 97x51x99 | ●    |

**Swivel casters for easy manoeuvrability. Ergonomic handles, high load capacity 135 kg (45 kg per shelf). Ultra-quiet mark-resistant casters.**  
Maniglie ergonomiche arrotondate, pannelli laterali e bordo paraurti arrotondato. Portata 135 kg (45 kg per ripiano). Ruote girevoli, antitraccia e silenziose.



W

**Breakfast tray with legs**

Vassoio colazione con gambe  
Frühstückstablett mit Beinen  
Plateau petit déjeuner avec jambes  
Bandeja desayuno con patas

| art.     | dim. cm.     | col. |
|----------|--------------|------|
| 19902-38 | 58,5x38,5x30 | ●    |

Wengè.



W

**Room service tray**

Vassoio room service  
Zimmerservice-Tablett  
Plateau room-service  
Bandeja room service

| art.     | dim. cm. | col. |
|----------|----------|------|
| 19901-35 | 52x35    | ●    |
| 19901-40 | 60x40    | ●    |
| 19901-47 | 71x47    | ●    |

Dark walnut. – Noce scuro.





**NEW SERVICE CONCEPT**



**2-tier service trolleys with hygienic plexiglas dome cover double side opening and 4 standard swivel wheels, 2 with brake. A new way of serving food safely and fighting COVID 19 by clearly dividing the kitchen side and the service side to avoid contamination and have the most hygienic service possible.**

Carrelli di servizio a 2 piani dotati di cupola igienica in plexiglas apribile sui 2 lati e 4 ruote girevoli di cui 2 con freno. Un nuovo modo di servire gli alimenti in sicurezza e combattere COVID 19 dividendo chiaramente il lato cucina e il lato servizio per evitare contaminazioni e avere il servizio più igienico possibile.



**Serving trolley**

Carrello servizio  
Servierwagen  
Chariot à servir  
Carro de servicio

art. dim. cm.

49996-00 89x47x103

**Chromed structure, shelves elm color, perimeter barrier lower deck, sliding plate shelf upper deck, wheels Ø 100 mm.**

Struttura cromata, ripiani color olmo, spondine di contenimento piano inferiore, pianetto estraibile, ruote Ø 100 mm.

**Serving trolley**

Carrello servizio  
Servierwagen  
Chariot à servir  
Carro de servicio

art. dim. cm.

49996-01 89x47x103

**Chromed structure, shelves elm color, wheels Ø 100 mm.**

Struttura cromata, ripiani color olmo, ruote Ø 100 mm.



**Serving trolley**

Carrello servizio  
Servierwagen  
Chariot à servir  
Carro de servicio

art. dim. cm.

49996-05 89x47x103

**Painted structure, shelves grey color, wheels Ø 100 mm.**

Struttura verniciata, ripiani colore grigio, ruote Ø 100 mm.





A range of service tables and trolleys designed to allow guests to comfortably and safely receive and consume breakfast or dinner in their room. Hot boxes made of AISI 304 stainless steel with double insulated wall. Analogic thermostat 30-90°C with indicator light. Equipped with two inner height-adjustable grids. Suitable for dishes up to Ø 32 cm. Refrigerated boxes made of AISI 304 stainless steel with double insulated wall with chilling pack -32°C inserted in a condensate collector basket placed on the upper grid. Chill for about 5 hours. Room service tables: chrome tube structure, 2 castors with brake. Top Ø 90 cm made of CDF (Compact Density Fibreboard). Can carry up to 2 boxes.

Una gamma di tavoli e carrelli per il servizio in camera per permettere agli ospiti di ricevere e consumare comodamente e in piena sicurezza la colazione o la cena in stanza. Box termici in acciaio inox AISI 304 a doppia parete coibentata. Termostato analogico 30-90°C con spia luminosa di funzionamento. Forniti con due griglie interne regolabili in altezza. Idonei per piatti fino a Ø 32 cm. Box refrigerati in acciaio inox AISI 304 a doppia parete coibentata. Refrigerazione a mezzo di una piastra eutettica -32°C inserita in un cesto di raccolta posizionato sulla griglia superiore. Raffreddare per c.ca 5 ore. Tavolini: struttura in tubo cromato, 2 ruote con freno. Piano Ø 90 cm in CDF (Compact Density Fibreboard). Possono trasportare fino a 2 box.



**Thermic hot box**

Box termico  
Speisen-Kaste  
Caisson thermique  
Cajón térmico

| art.     | dim. cm.     | W   |
|----------|--------------|-----|
| 44094-00 | 38x40,5x51,2 | 500 |

**Refrigerated box**

Box refrigerato  
Speisen-Kaste  
Caisson réfrigéré  
Cajón refrigerado

| art.     | dim. cm.   |
|----------|------------|
| 44094R00 | 38x40,5x51 |



**Room service table**

Tavolino room service  
Zimmerservice-Tisch  
Table de restauration en chambre  
Carrito de servicio de habitaciones

| art.     | Ø cm.   | h. cm. |
|----------|---------|--------|
| 44094-01 | 90/54,6 | 77     |



**Room service table with hot box**

Tavolino room service con hot box  
Zimmerservice-Tisch mit Hot Box  
Table de restauration en chambre avec hot box  
Carrito de servicio de habitaciones con hot box

| art.     | Ø cm.   | h. cm. | W   |
|----------|---------|--------|-----|
| 44094-02 | 90/54,6 | 77     | 500 |

**44094-00 + 44094-01.**

With fold down flaps for easy crossing of doors and lifts.  
Con flaps pieghevoli per attraversare porte e ascensori.



**Room service table**

Tavolino room service  
Zimmerservice-Tisch  
Table de restauration en chambre  
Carrito de servicio de habitaciones

art. Ø cm. h. cm. closed/chiuso  
44094-03 90/54,6 78,6 74x54x117

**With fold down flaps for easy crossing of doors and lifts. With capsizable top for stacking when not in use.** – Con flaps pieghevoli per attraversare porte e ascensori. Ribaltabile e impilabile quando non in uso.



**Room service table with hot box**

Tavolino room service con hot box  
Zimmerservice-Tisch mit Hot Box  
Table de restauration en chambre avec hot box  
Carrito de servicio de habitaciones con hot box

art. Ø cm. h. cm. W  
44094-04 90/54,6 78,6 500

**44094-00 + 44094-03.**



**Room service table**

Tavolino room service  
Zimmerservice-Tisch  
Table de restauration en chambre  
Carrito de servicio de habitaciones

art. Ø cm. h. cm. closed/chiuso  
44094-05 90/73 76 73x33x98

**With fold down flaps for easy crossing of doors and lifts. Foldable for saving space when not in use.** – Con flaps pieghevoli per attraversare porte e ascensori. Pieghevole per ridurre l'ingombro quando non in uso.



**Room service table with hot box**

Tavolino room service con hot box  
Zimmerservice-Tisch mit Hot Box  
Table de restauration en chambre avec hot box  
Carrito de servicio de habitaciones con hot box

art. Ø cm. h. cm. W  
44094-06 90/73 76 500

**44094-00 + 44094-05.**



**Serving trolley**

Carrello servizio  
Servierwagen  
Chariot à servir  
Carro de servicio

art. des. dim. cm.  
49996-01 trolley 89x47x103  
44094-00 hot box 38x40,5x51,2  
44094R00 cold box 38x40,5x51

**With hygienic plexiglas dome cover double side opening. The trolley can be equipped with 2 hot and/or cold boxes. Ideal for maintaining the temperature of food and for the room service.** – Cupola igienica in plexiglas apribile sui 2 lati. Il carrello è equipaggiabile con 2 box termici caldi e/o freddi. Ideale per mantenere la temperatura delle portate e per il servizio in camera.



**Serving trolley**

Carrello servizio  
Servierwagen  
Chariot à servir  
Carro de servicio

art. des. dim. cm.  
49996-05 trolley 89x47x103  
44094-00 hot box 38x40,5x51,2  
44094R00 cold box 38x40,5x51

**With hygienic plexiglas dome cover double side opening. The trolley can be equipped with 2 hot and/or cold boxes. Ideal for maintaining the temperature of food and for the room service.** – Con cupola igienica in plexiglas apribile sui 2 lati. Il carrello è equipaggiabile con 2 box termici caldi e/o freddi. Ideale per mantenere la temperatura delle portate e per il servizio in camera.



# SERIES 14000

STORAGE & TRANSPORT  
STOCCAGGIO E TRASPORTO



Molded in one-piece with double-wall construction made of polypropylene. Resistant to shock, high temperatures and chemicals. Designed to give optimum protection to glass and chinaware as well as to maximise water circulation and drying in professional dishwasher. Easy and quickly stackable without tools or screws. Base racks have comfortable hand grips on all four sides facilitating handling.

Realizzati in polipropilene, stampati unipezzo a doppio spessore. Resistenti agli urti ed alte temperature, agenti chimici e residui alimentari. Concepiti per assicurare una protezione ottimale a bicchieri e stoviglie, il loro design permette inoltre una perfetta circolazione dell'acqua di lavaggio ed una rapida e perfetta asciugatura. Facili e veloci da impilare. Leggeri e maneggevoli, tutti i cestelli di base sono dotati di maniglie integrali su tutti i lati.







**9-Compartment base**

Cestello 9 bicchieri  
Grundkorb für 9 Gläser  
Panier de base 9 verres  
Cesta 9 compartimentos

art. mm.

14001-09 500x500x103

**Compartments / Scomparti 151x151x42 mm.  
ø max 151 mm.**



**9-Compartment extender**

Estensore per cestello 9 bicchieri  
Aufsatz zum Grundkorb für 9 Gläser  
Réhausse pour panier de base 9 verres  
Extensión 9 compartimentos

art. mm.

14003-09 500x500x45

**Compartments / Scomparti 151x151x88 mm.  
ø max 151 mm.**



**16-Compartment base**

Cestello 16 bicchieri  
Grundkorb für 16 Gläser  
Panier de base 16 verres  
Cesta 16 compartimentos

art. mm.

14001-16 500x500x103

**Compartments / Scomparti 112x112x88 mm.  
ø max 112 mm.**



**16-Compartment extender**

Estensore per cestello 16 bicchieri  
Aufsatz zum Grundkorb für 16 Gläser  
Réhausse pour panier de base 16 verres  
Extensión 16 compartimentos

art. mm.

14003-16 500x500x45

**Compartments / Scomparti 112x112x42 mm.  
ø max 112 mm.**



**25-Compartment base**

Cestello 25 bicchieri  
Grundkorb für 25 Gläser  
Panier de base 25 verres  
Cesta 25 compartimentos

art. mm.

14001-25 500x500x103

**Compartments / Scomparti 88x88x88 mm.  
ø max 88 mm.**



**25-Compartment extender**

Estensore per cestello 25 bicchieri  
Aufsatz zum Grundkorb für 25 Gläser  
Réhausse pour panier de base 25 verres  
Extensión 25 compartimentos

art. mm.

14003-25 500x500x45

**Compartments / Scomparti 88x88x42 mm.  
ø max 88 mm.**



**36-Compartment base**

Cestello 36 bicchieri  
Grundkorb für 36 Gläser  
Panier de base 36 verres  
Cesta 36 compartimentos

art. mm.

14001-36 500x500x103

**Compartments / Scomparti 73x73x88 mm.  
ø max 73 mm.**



**36-Compartment extender**

Estensore per cestello 36 bicchieri  
Aufsatz zum Grundkorb für 36 Gläser  
Réhausse pour panier de base 36 verres  
Extensión 36 compartimentos

art. mm.

14003-36 500x500x45

**Compartments / Scomparti 73x73x42 mm.  
ø max 73 mm.**



**49-Compartment base**

Cestello 49 bicchieri  
Grundkorb für 49 Gläser  
Panier de base 49 verres  
Cesta 49 compartimentos

art. mm.

14001-49 500x500x103

**Compartments / Scomparti 62x62x42 mm.  
ø max 62 mm.**



**49-Compartment extender**

Estensore per cestello 49 bicchieri  
 Aufsatz zum Grundkorb für 49 Gläser  
 Réhausse pour panier de base 49 verres  
 Extensión 49 compartimentos

art. mm.  
 14003-49 500x500x45

**Compartments / Scomparti 62x62x42 mm.  
 ø max 62 mm.**



**Open extender**

Estensore aperto  
 Universalrand ohne Einteilung  
 Réhausse sans cloisons  
 Extensión abierta

art. mm.  
 14004-00 500x500x42



**Rack cover**

Coperchio per cestelli  
 Deckel für Körbe  
 Couvercle à panier  
 Tapa para cestas

art. mm.  
 14011-00 505x505x25



**Open rack**

Cestello universale  
 Universal-Korb  
 Panier universel  
 Cesta universal

art. mm.  
 14010-00 500x500x103



**Cutlery rack**

Cestello per posate  
 Besteckkorb  
 Panier à couverts  
 Cesta para cubiertos

art. mm.  
 14006-00 500x500x103



**Plates & trays rack**

Cestello per piatti e vassoi  
 Tablett- u. Tellerkorb mit Fingern  
 Panier à plateaux et assiettes  
 Cesta para bandejas y platos

art. mm.  
 14008-00 500x500x103

**For 18 flat plates or 9 trays max. 460 mm.**  
 Per 18 piatti piani oppure 9 vassoi max. 460 mm.



**Tray rack, open**

Cestello per vassoi, aperto  
 Tablettkorb mit Fingern, offen  
 Panier à plateaux, ouvert  
 Cesta abierto para bandejas

art. mm.  
 14007-00 500x500x103

**For trays over 460 mm. Capacity 9 pcs.**  
 Per vassoi oltre 460 mm. Cap. 9 pz.



**Clip tags, 10-pcs set**

Etichette di identificazione, set 10 pz  
 Markierungsklipp, 10 Stk.  
 Clips, set 10 pièces  
 Etiquetas, set 10 piezas

art. mm.  
 14013-00 80x40



**Cutlery holder 8 compartments**

Cestello per posate 8 scomparti  
 Besteckkorb, 8 Unterteilungen  
 Panier à couverts 8 compartiments  
 Cesta para cubiertos

art. mm.  
 14015-08 426x206x150

**For 200/250 pcs cutlery. – Per 200/250 posate.**





**SS**

**Cutlery dispenser**  
Porta posate  
Besteckbehälter  
Réceptient à couverts  
Contenedor para cubiertos

art. cm.  
42587-04 26x30x20



**SS**

**Cutlery holder**  
Cestello porta posate  
Besteckbehälter  
Réceptient à couverts  
Cestillo para cubiertos

art. Ø cm. h. cm.  
42586-10 10 14



**PE**

**Cutlery holder**  
Cestello porta posate  
Besteckbehälter  
Réceptient à couverts  
Cestillo para cubiertos

art. Ø cm. h. cm.  
42586-09 9,5 13,5



**PP**

**Cutlery dispenser**  
Porta posate  
Besteckbehälter  
Réceptient à couverts  
Contenedor para cubiertos

art. cm.  
42585-06 54x33x13



**PE**

**Cutlery dispenser**  
Porta posate  
Besteckbehälter  
Réceptient à couverts  
Contenedor para cubiertos

art. cm. GN h. cm.  
42585-04 32,5x53 1/1 10



**PP**

**Cutlery box lid**  
Coperchio per porta posate  
Deckel für Besteckbehälter  
Couvercle pour réceptient à couverts  
Tapa para contenedor cubiertos

art. cm.  
42585-00 32,5x53x2

**Fits/Per: 42585-04.**



**Dolly with handle**  
Carrello con maniglione  
Transportwagen mit Griff  
Chariot avec poignée  
Carretilla con manillar

art. cm. Kg.  
44023-00 54x54x75 10

**Polypropylene base. – Base in PP.**



**Dolly without handle**  
Carrello senza maniglione  
Transportwagen ohne Griff  
Chariot sans poignée  
Carretilla sin manillar

art. cm. Kg.  
44024-00 54x54 8,5

**Polypropylene base. – Base in PP.**



**Dolly, aluminum/ABS**  
Carrello, alluminio/ABS  
Transportwagen, Aluminium/ABS  
Chariot, aluminium/ABS  
Carro, aluminio/ABS

art. cm.  
44975C50 51x51



SS

**Dolly with handle**  
 Carrello con maniglione  
 Transportwagen mit Griff  
 Chariot avec poignée  
 Carretilla con manillar

art. cm.  
 44025-50 55x55x9

**Removable handle, with drip and drain plug. Load 60 kg. –** Manico estraibile, tappo di scarico. Carico 60 kg.



**Dust cover**  
 Copertura protettiva  
 Schutzhülle  
 Housse de protection  
 Cuberta protectora

art. cm.  
 44009-00 55x55x122



SS

**Trolley 3 levels**  
 Carrello 3 livelli  
 3-stöckiger Wagen  
 Chariot à 3 étages  
 Carro 3 pisos

art. cm.  
 44020-21 100x50x178,5

**Suitable for 24 racks.**  
 Carico verticale per 24 cestelli.



PP

**Multipurpose box**  
 Recipiente  
 Behälter  
 Conteneur multiservice  
 Contenedor

art. cm.  
 44031-04 52x39x12,7  
 44031-05 52x39x17,7

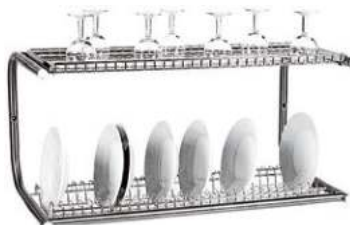

SS

**Wall draining rack**  
 Scolapiatti a muro  
 Wand-Trockengestell  
 Egouttoir au mur  
 Escurridor mural de platos

art. cm.  
 44029-00 87x30x20

**Load/Carico: 70 kg.**



**Wire dish rack**  
 Porta piatti in filo metallo/rilsan  
 Tellergerüst  
 Porte-assiettes

**Porta platos**

| art.     | Ø cm. | h. cm. |
|----------|-------|--------|
| 44047-17 | 17    | 30     |
| 44047-19 | 19    | 30     |
| 44047-22 | 22    | 30     |
| 44047-25 | 25    | 30     |
| 44047-28 | 28    | 30     |



SS

**Dish dolly**  
 Carrello portapiatti  
 Teller-Transportwagen  
 Chariot porte-assiettes  
 Carro porta platos

art. cm.  
 44027-00 74x61x81

**Load/Carico max: 240 kg.**



PE

**Adjustable dish dolly**  
 Carrello portapiatti regolabile  
 Teller-Transportwagen, einstellbar  
 Chariot de stockage d'assiettes réglable  
 Carro ajustable para platos

art. cm. Kg.  
 49304-06 73x73x82 28

**With dust cover and 4 dividers. Dishes Ø cm 18-32,5 capacity 180/480 pcs. 2 wheels with brake.**  
 Con copertura vinilica e 4 divisori. Per piatti Ø cm 18-32, capienza 180/480 pz. 2 ruote con freno.

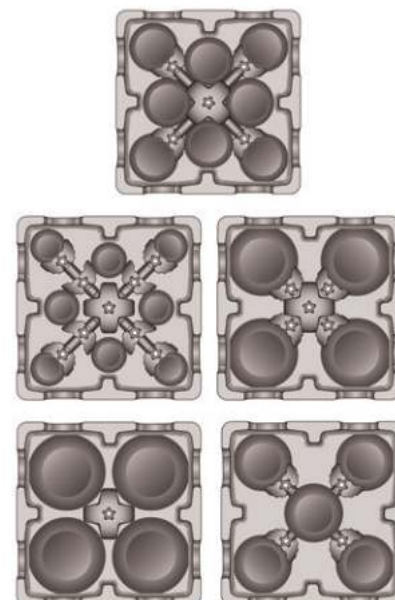



**CROCKERY TRANSPORT BOX**  
CONTENITORE PER IL TRASPORTO DI STOVIGLIE

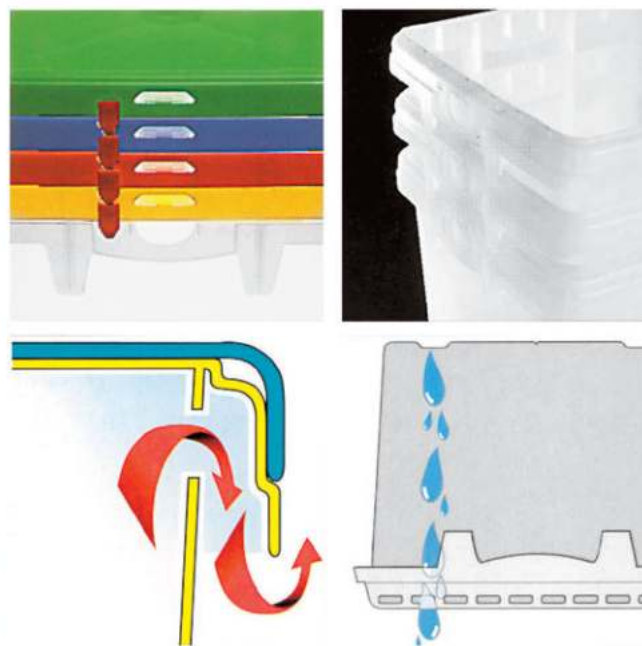

Clear polypropylene construction, full compliance with food contact requirements. A removable tower insert provides total flexibility. Strong, it prevents dish breakage in transport. Dimensions suitable to EURO-pallets. Lids are tightly fitting, hygienic, dish-washer safe. Covers available in different colors, assure easy and quick content identification. Stackable once empty, their strongness provides high loading density once full. Ventilation holes assure constant air circulation. Design studied to enable water flow while washing.

Contenitori in polipropilene trasparente per alimenti. Estremamente resistenti alle sollecitazioni, offrono protezione sicura nel trasporto. Dimensioni adatte a EURO-pallets. Adatti al lavaggio in lavastoviglie, design studiato per consentire il defluire dell'acqua. Coperchi di colore diverso facilitano l'individuazione del contenuto. Impilabili, a pieno la loro robustezza consente un'elevata capacità di sovrapposizione. Fessure di aerazione per un costante ricambio d'aria.



**Storage box**  
Contenitore  
Korb  
Panier  
Contenedor

| art.     | cm.        | lt. |
|----------|------------|-----|
| 44040-40 | 40x40x31,5 | 32  |



**Base insert**  
Fondo piatto  
Flach-Einsatz  
Plateau double fond  
Base plana

| art.     | cm.   |
|----------|-------|
| 44042-00 | 40x40 |



**Cross insert**  
Inserto croce  
Kreuz-Einsatz  
Cloison à croix  
Separador a cruz

| art.     | cm.   |
|----------|-------|
| 44043-00 | 40x40 |



**Cover**  
Coperchio  
Deckel  
Couvercle  
Tapa

| art.     | col. |
|----------|------|
| 44041-00 | ○    |
| 44041-01 | ●    |
| 44041-03 | ●    |



**Cover**  
Coperchio  
Deckel  
Couvercle  
Tapa

| art.     | col. |
|----------|------|
| 44041-04 | ●    |
| 44041-05 | ●    |



**Tower insert**  
Tubo fermapiatti  
Rohr-Einsatz  
Tuyau  
Tubo

| art.     |
|----------|
| 44044-00 |

## SQUARE & ROUND CONTAINERS CONTENITORI QUADRATI & ROTONDI



**Space-saving SQUARE containers.** In transparent anti-breaking material to identify the contents. Graduated measurements: red for US sizes and blue for liters. Resistant handles. Drainage holes. They withstand temperatures between  $-40^{\circ}\text{C}$  and  $100^{\circ}\text{C}$ . Lids with hermetic pressure closure and corner tab for easy removal.

**ROUND stackable containers.** Reinforced rims. Drainage holes. They withstand temperatures between  $-28^{\circ}\text{C}$  and  $65^{\circ}\text{C}$ . Dishwasher safe. Tight-fitting lids with double barrier and opening flap in the corner. Writing area on the cover to specify date and content.

Contenitori QUADRATI salvaspazio. In materiale infrangibile, trasparente per identificare il contenuto. Misurazioni graduate: rosse per le misure USA e blu per i litri. Impugnature resistenti. Fori di drenaggio. Resistono a temperature comprese fra i  $-40^{\circ}\text{C}$  e i  $100^{\circ}\text{C}$ . Coperchi a chiusura ermetica a pressione e linguetta per una rimozione agevole.

Contenitori ROTONDI impilabili. Bordi rinforzati. Fori di drenaggio. Resistono a temperature comprese fra i  $-28^{\circ}\text{C}$  e i  $65^{\circ}\text{C}$ . Lavabili in lavastoviglie. I coperchi sono a chiusura ermetica con doppia barriera e linguetta di apertura nell'angolo. Consentono l'indicazione della data e del contenuto in un'apposita area di scrittura.



### Food container, copolyester

Contenitore per alimenti, copoliestere  
Vorratsdosen, Copoliéster  
Conteneur pour aliments, copolyester  
Contenedor para alimentos, copolyester

| art.     | cm.        | lt. |
|----------|------------|-----|
| 44620-01 | 22x21x7    | 1,9 |
| 44620-02 | 22x21x12   | 3,8 |
| 44620-03 | 22x21x17,5 | 5,7 |
| 44620-04 | 22x21x22   | 7,6 |



### Food container, copolyester

Contenitore per alimenti, copoliestere  
Vorratsdosen, Copoliéster  
Conteneur pour aliments, copolyester  
Contenedor para alimentos, copolyester

| art.     | cm.        | lt.  |
|----------|------------|------|
| 44620-05 | 29x27x19   | 11,4 |
| 44620-06 | 29x27x30   | 17,0 |
| 44620-07 | 29x27x36,5 | 20,8 |



PE

### Square lid

Coperchio quadrato  
Deckel, viereckig  
Couvercle carré  
Tapa cuadrada

| art.     | cm.   |
|----------|-------|
| 44620-14 | 22x21 |
| 44620-17 | 29x27 |



PP

### Food container

Contenitore per alimenti  
Vorratsdosen  
Conteneur pour aliments  
Contenedor para alimentos

| art.     | Ø cm. | h. cm. | lt.  |
|----------|-------|--------|------|
| 44625-03 | 25    | 19,5   | 5,7  |
| 44625-04 | 25    | 27,0   | 7,6  |
| 44625-05 | 33    | 20,5   | 11,4 |
| 44625-06 | 33    | 30,0   | 17,0 |



PP

### Food container

Contenitore per alimenti  
Vorratsdosen  
Conteneur pour aliments  
Contenedor para alimentos

| art.      | Ø cm. | h. cm. | lt.  |
|-----------|-------|--------|------|
| 44625-07  | 33    | 35,5   | 20,8 |
| 44625-08* | 33    | 35,5   | 20,8 |

\*With handle. – Con manico.



PE

### Round lid

Coperchio rotondo  
Deckel, rund  
Couvercle rond  
Tapa redonda

| art.     | Ø cm. | col. |
|----------|-------|------|
| 44625-26 | 25    | ●    |
| 44625-34 | 33    | ●    |





PC

**Food container**

Contentore per alimenti  
Nahrungsmittel-Behälter  
Conteneur pour aliments  
Contenedor para alimentos

| art.     | cm.        | lt.  |
|----------|------------|------|
| 49384-03 | 45,7x30x23 | 19,0 |
| 49384-04 | 45,7x66x9  | 19,0 |
| 49384-05 | 45,7x66x15 | 32,3 |
| 49384-06 | 45,7x66x23 | 47,0 |
| 49384-07 | 45,7x66x38 | 81,5 |



PC

**Drain tray**

Vasca di drenaggio  
Abtropf-Behälter  
Conteneur perforé  
Contenedor para colar

| art.     | cm.        |
|----------|------------|
| 49384-11 | 45,7x66x12 |



PC

**Lid**

Coperchio  
Deckel  
Couvercle  
Tapa

| art.     | cm.     |
|----------|---------|
| 49384-14 | 45,7x30 |
| 49384-15 | 45,7x66 |



PP

**Food container**

Contentore per alimenti  
Nahrungsmittel-Behälter  
Conteneur pour aliments  
Contenedor para alimentos

| art.     | cm.        | lt.  |
|----------|------------|------|
| 49382-10 | 30x38x21,5 | 10,0 |
| 49382-23 | 60x49x43   | 23,5 |
| 49382-47 | 60x29x43   | 47,0 |



PP

**Storage container**

Carrello per derrate alimentari  
Fahrbares Nahrungsmittelbehälter  
Chariot mobile de stockage  
Contenedor para hortalizas

| art.     | cm.          | lt.  |
|----------|--------------|------|
| 49381-01 | 74x33,5x71   | 79,0 |
| 49381-02 | 75x39,5x71   | 97,5 |
| 49381-03 | 75,5x45,5x71 | 116  |



PE

**Container, round**

Contentore tondo  
Behälter, rund  
Conteneur, rond  
Contenedor redondo

| art.     | Ø cm. | h. cm. | lt.   |
|----------|-------|--------|-------|
| 49373-01 | 39,7  | 43,5   | 37,9  |
| 49373-02 | 49,5  | 58,1   | 75,7  |
| 49373-03 | 55,9  | 69,2   | 121,1 |
| 49373-04 | 67,3  | 83,8   | 208,2 |



PE

**Lid, round**

Coperchio tondo  
Deckel, rund  
Couvercle, rond  
Tapa redonda

| art.     | Ø cm. | h. cm. |
|----------|-------|--------|
| 49373-11 | 40,6  | 2,5    |
| 49373-12 | 50,5  | 3,2    |
| 49373-13 | 56,5  | 3,5    |
| 49373-14 | 67,9  | 5,1    |



PE

**Dolly**

Supporto mobile  
Wagen  
Chariot  
Soporte móvil

| art.     | Ø cm. | h. cm. |
|----------|-------|--------|
| 49373-90 | 46,4  | 17     |

**Load/Carico: 113,4 kg.**



SS

**Sink trolley**

Carrello vasca  
Obst/Gemüsewaschwagen  
Chariot à évier  
Carro-cuba lavado verduras

| art.     | cm.      | lt. |
|----------|----------|-----|
| 44028-19 | 80x60x75 | 190 |

**Tub with tap, brushed finish. Stamped bottom watertight, without edges.** – Vasca con rubinetto, finitura spazzolata. Fondo stampato a tenuta stagna, privo di spigoli.





**Bread basket**

Cesto pane  
Brot-Korb  
Corbeille à pain  
Cesta pan

| art.     | cm.      | lt. |
|----------|----------|-----|
| 44982-04 | 57x36x34 | 40  |
| 44982-06 | 66x45x35 | 60  |
| 44982-10 | 78x52x40 | 100 |



**Space saving box with cover**

Contenitore con coperchio  
Behälter mit Deckel  
Récipient avec couvercle  
Contenedor con tapa

| art.     | cm.      |
|----------|----------|
| 44033-23 | 66x45x23 |
| 44033-38 | 67x46x38 |



**Gastronorm basket**

Cesto gastronorm  
Gastronorm-Korb  
Panier gastronorme  
Cesta gastronorm

| art.     | cm.        |
|----------|------------|
| 44034-11 | 59x39x19,5 |

**STACKABLE CONTAINERS**  
CONTENITORI SOVRAPPONIBILI



**Stackable containers, external dimensions 600x400 mm and 400x300 mm, they perfectly fit to 800x1200 mm EUR pallets and to 1000x1200 mm. Available in different heights and versions. High density polyethylene HDPE. A thermoplastic that offers excellent impact resistance at low temperatures (from -30°C to +70°C).**

Contenitori sovrapponibili con dimensioni esterne di mm 600x400 e 400x300 perfettamente pallettizzabili su pallet EUR mm 800x1200 e 1000x1200. Disponibili in diverse altezze e versioni. Polietilene alta densità HDPE. Uno dei materiali termoplastici più dotato di resistenza all'impatto con basse temperature (da -30°C a +70°C).



**Container**

Contenitore  
Behälter  
Conteneur  
Contenedor

| art.     | cm.      | lt. |
|----------|----------|-----|
| 44511E21 | 60x40x10 | 21  |
| 44511E63 | 60x40x32 | 63  |
| 44511E90 | 60x40x45 | 90  |

**Solid bottom and sides. – Fondo e pareti chiuse.**



**Container**

Contenitore  
Behälter  
Conteneur  
Contenedor

| art.     | cm.      | lt. |
|----------|----------|-----|
| 44512E12 | 60x40x7  | 12  |
| 44512E21 | 60x40x10 | 21  |

**Solid bottom and perforated sides.**  
Fondo chiuso e pareti forate.



**Container**

Contenitore  
Behälter  
Conteneur  
Contenedor

| art.     | cm.      | lt. |
|----------|----------|-----|
| 44513E12 | 60x40x7  | 12  |
| 44513E21 | 60x40x10 | 21  |

**Perforated bottom and sides.**  
Fondo e pareti forate.







PP

**Lid**  
Coperchio  
Deckel  
Couvercle  
Tapa

| art.     | cm.     |
|----------|---------|
| 41763-00 | 60x40x2 |



PP

**Lid**  
Coperchio  
Deckel  
Couvercle  
Tapa

| art.     | cm.     |
|----------|---------|
| 41763-30 | 40x30x2 |



**Container**  
Contentitore  
Behälter  
Conteneur  
Contenedor

| art.     | cm.      | lt. |
|----------|----------|-----|
| 44521E10 | 40x30x12 | 10  |

**Solid bottom and sides. – Fondo e pareti chiuse.**



**Container**  
Contentitore  
Behälter  
Conteneur  
Contenedor

| art.     | cm.      | lt. |
|----------|----------|-----|
| 44521-16 | 40x30x17 | 16  |
| 44521-21 | 40x30x22 | 21  |
| 44521-31 | 40x30x32 | 31  |

**Solid bottom and sides. – Fondo e pareti chiuse.**



**Container**  
Contentitore  
Behälter  
Conteneur  
Contenedor

| art.     | cm.      | lt. |
|----------|----------|-----|
| 44511-27 | 60x40x15 | 27  |
| 44511-34 | 60x40x17 | 34  |
| 44511-38 | 60x40x20 | 38  |
| 44511-42 | 60x40x22 | 42  |
| 44511-63 | 60x40x32 | 63  |
| 44511-90 | 60x40x45 | 90  |

**Solid bottom and sides. – Fondo e pareti chiuse.**



**Container**  
Contentitore  
Behälter  
Conteneur  
Contenedor

| art.     | cm.      | lt. |
|----------|----------|-----|
| 44522E10 | 40x30x12 | 10  |

**Solid bottom and perforated sides. – Fondo chiuso e pareti forate.**



**Container**  
Contentitore  
Behälter  
Conteneur  
Contenedor

| art.     | cm.      | lt. |
|----------|----------|-----|
| 44522-16 | 40x30x17 | 16  |
| 44522-21 | 40x30x22 | 21  |
| 44522-31 | 40x30x32 | 31  |

**Solid bottom and perforated sides. – Fondo chiuso e pareti forate.**



**Container**  
Contentitore  
Behälter  
Conteneur  
Contenedor

| art.     | cm.      | lt. |
|----------|----------|-----|
| 44512-34 | 60x40x17 | 34  |
| 44512-42 | 60x40x22 | 42  |
| 44512-63 | 60x40x32 | 63  |
| 44512-90 | 60x40x45 | 90  |

**Solid bottom and perforated sides. – Fondo chiuso e pareti forate.**



**Container**  
Contentitore  
Behälter  
Conteneur  
Contenedor

| art.     | cm.      | lt. |
|----------|----------|-----|
| 44513-34 | 60x40x17 | 34  |
| 44513-38 | 60x40x20 | 38  |
| 44513-54 | 60x40x29 | 54  |
| 44513-63 | 60x40x32 | 63  |
| 44513-90 | 60x40x45 | 90  |

**Perforated bottom and sides. – Fondo e pareti forate.**

## POLYPROPYLENE CONTAINERS CONTENITORI POLIPROPILENE



They do not hand over odours or flavours to foods. Easy to wash and disinfect after use. Light and free of protrusions and sharp edges. Resistant, hygienic, economic, 100% recyclable, without CFC. Suitable for industrial washing and disinfection with detergents and disinfectants, hot water, and wet vapour up to 110°C (HACCP System). Suitable to protect food thermal stresses.

Non cedono odori e sapori agli alimenti, facilmente lavabili e sanificabili. Leggeri e privi di sporgenze e spigoli vivi. Resistenti, igienici, ecologici e riciclabili al 100%, senza CFC. Compatibili al lavaggio e alla disinfezione industriale con detergenti e disinfettanti, acqua calda e vapore umido fino a 110°C (HAACCP System). Idonei a proteggere gli alimenti da sollecitazioni termiche.



### Insulated container POWERBOX

Contentitore isotermico  
Thermobehälter  
Conteneur isotherme  
Contenedor isotérmico

| art.     | cm.          | lt. |
|----------|--------------|-----|
| 44961-05 | 64,5x40x31,5 | 45  |



### Insulated container UNIVERSAL PN

Contentitore isotermico  
Thermobehälter  
Conteneur isotherme  
Contenedor isotérmico

| art.     | cm.        | lt.  |
|----------|------------|------|
| 44986-12 | 61x43x20   | 24,0 |
| 44986-17 | 61x43x25   | 33,8 |
| 44986-21 | 61x43x29,5 | 42,8 |
| 44986-28 | 61x43x36,5 | 56,7 |



### Insulated container GN 1/2

Contentitore isotermico  
Thermobehälter  
Conteneur isotherme  
Contenedor isotérmico

| art.     | cm.          | lt.  |
|----------|--------------|------|
| 44972-20 | 41,5x32x28,5 | 20,3 |
| 44972-25 | 41,5x32x32   | 21,6 |
| 44972-33 | 41,5x32x40   | 31,2 |



### Insulated container GN 1/1

Contentitore isotermico  
Thermobehälter  
Conteneur isotherme  
Contenedor isotérmico

| art.     | cm.        | lt.  |
|----------|------------|------|
| 44970-10 | 60x40x17   | 20,2 |
| 44970-15 | 60x40x23   | 31,2 |
| 44970-20 | 60x40x27   | 38,6 |
| 44970-34 | 60x40x34,5 | 52,3 |



### OPTIONAL 44970 - Sling & dolly

Imbragature e carrello  
Gurt und Wagen  
Sangle et chariot  
Correa y carro

| art.     | cm.   |
|----------|-------|
| 44987C62 | 62x42 |
| 44973-10 | sling |
| 44973-20 | sling |



### Insulated container PLUS GN 1/1

Contentitore isotermico  
Thermobehälter  
Conteneur isotherme  
Contenedor isotérmico

| art.     | cm.        | lt.  |
|----------|------------|------|
| 44978-10 | 68x44,5X20 | 24,9 |
| 44978-20 | 68x44,5X30 | 45,6 |



### Insulated pastry container

Contentitore isotermico pasticceria  
Konditorei-Thermobehälter  
Conteneur isotherme à pâtisserie  
Contenedor isotérmico para pastelería

| art.     | cm.          | lt.  |
|----------|--------------|------|
| 44974-21 | 68,5x48,5x27 | 55,8 |
| 44974-27 | 68,5x48,5x33 | 71,7 |
| 44974-31 | 68,5x48,5x37 | 82,3 |



### Insulated container HANDTOP

Contentitore isotermico  
Thermobehälter  
Conteneur isotherme  
Contenedor isotérmico

| art.     | cm.          | lt. |
|----------|--------------|-----|
| 44961-06 | 71,5x40x31,5 | 45  |

### Incorporated ergonomic handles. For Gastronorm 1/1 or submultiples.

Maniglie ergonomiche incorporate. Trasporta Gastronorm da 1/1 o sottomultipli.



### Insulated container TROLLEYBOX

Contentitore isotermico  
Thermobehälter  
Conteneur isotherme  
Contenedor isotérmico

| art.     | cm.      | lt. |
|----------|----------|-----|
| 44961-04 | 42x42x60 | 60  |





**Insulated container BOXSHOP**

Contentitore isotermico  
Thermobehälter  
Conteneur isotherme  
Contenedor isotérmico

| art.     | cm.        | lt.  |
|----------|------------|------|
| 44961-02 | 41,5x32x40 | 31,2 |



**Insulated container PIZZABOX**

Contentitore isotermico  
Thermobehälter  
Conteneur isotherme  
Contenedor isotérmico

| art.     | cm.        | lt. |
|----------|------------|-----|
| 44961-03 | 42x42x34,5 | 36  |

**With steam release system.**  
Con sistema di rilascio del vapore.



**Insulated container POPTER GN 1/1**

Contentitore isotermico  
Thermobehälter  
Conteneur isotherme  
Contenedor isotérmico

| art.     | cm.      | lt. |
|----------|----------|-----|
| 44987-11 | 65x50x61 | 83  |

**For GN 1/1 or submultiples. 12 guides.**  
Per GN 1/1 o sottomultipli. 12 guide.



**Insulated container PORTER MAXI**

Contentitore isotermico  
Thermobehälter  
Conteneur isotherme  
Contenedor isotérmico

| art.     | cm.      | lt. |
|----------|----------|-----|
| 44987-60 | 72x60x63 | 128 |

**Guides/Guide: 9**



**Insulated container GN CRYSTAL**

Contentitore isotermico  
Thermobehälter  
Conteneur isotherme  
Contenedor isotérmico

| art.     | cm.      | lt.  |
|----------|----------|------|
| 44968-00 | 60x40x30 | 45,4 |

**Inside crystallized and therefore perfectly smooth, rigid and waterproof.**  
Interno cristallizzato perfettamente liscio, rigido e impermeabile.



**Dolly, aluminum/ABS**

Carrello, alluminio/ABS  
Fahrgestell, Aluminium/ABS  
Chariot, aluminium/ABS  
Carro, aluminio/ABS

| art.     | cm.       | for/per  |
|----------|-----------|----------|
| 44975C50 | 58,5x58,5 | 44975-50 |
| 44987C11 | 68x52     | 44987-11 |
| 44987C60 | 75x61     | 44987-60 |
| 44987C62 | 62x42     | 44968-00 |



**Eutectic pad**

Accumulatore di freddo  
Kühlakku  
Cartouche eutectique  
Placa eutética

| art.     | cm.         | GN  |
|----------|-------------|-----|
| 44979-04 | 32,5x26,5x3 | 1/2 |
| 44979-05 | 53x32,5x3   | 1/1 |
| 44979-06 | 60x40x3     | -   |

**0/-21°C.**



**Heat accumulator**

Accumulatore di caldo  
Wärmespeicher  
Accumulateur de chaleur  
Acumulador de calor

| art.     | cm.       | GN  |
|----------|-----------|-----|
| 44979-02 | 53x32,5x3 | 1/1 |

**0/+85°C.**



**Insulated box**

Box isotermico  
Thermobehälter  
Conteneur isotherme  
Contenedor individual isotérmico

| art.     | cm.      |
|----------|----------|
| 44976-04 | 44x38x12 |

**3 sections for dishes ø 12 h 6 cm or 16x16 cm.**  
3 vani per piatti ø 12 h 6 cm o 16x16 cm.



**Insulated box DOMUS**

Box isothermico  
Thermobehälter  
Conteneur isotherme  
Contenedor individual isotérmico

art. cm.  
44976-02 42,5x26,5x16,5

**2 sections for dishes 18x18 cm.**  
2 vani per piatti 18x18 cm.



**Insulated box MONOKING**

Box isothermico  
Thermobehälter  
Conteneur isotherme  
Contenedor individual isotérmico

art. cm.  
44976-01 42,5x35x16

**2 insulated sections for dishes size 18x18 cm.**  
2 vani coibentati per piatti 18x18 cm.



**Insulated box THERMOKING**

Box isothermico  
Thermobehälter  
Conteneur isotherme  
Contenedor individual isotérmico

art. cm.  
44976-03 47x37x18,5

**Release latch lid. Usefull height 11,5 cm.**  
Coperchio a incastro. Altezza utile 11,5 cm.

**MODULAR SYSTEM BASE=LID EXTENSIBLE HEIGHT**  
**SISTEMA MODULARE BASE=COPERCHIO ALTEZZA ESTENSIBILE**



**Modular system, the base and lid are the same element and due to the extender insert it is possible to increase capacity. Equipped with rotation system that allows steam to escape.**

**Sistema modulare, base e coperchio sono lo stesso elemento e grazie all'inserto estensore è possibile aumentare la capacità. Provvisto di sistema rotabile, per la fuoriuscita del vapore.**



**Base and lid**

Base e coperchio  
Basis und Abdeckung  
Base et couvercle  
Base y tapa

art. cm. ext. int.  
44975-35 41x41x7,5 35,2x35,2x4,5  
44975-50 57x57x9,5 51x51x6,3



**Extender**

Estensore  
Aufsatz  
Réhausse  
Extensión

art. cm. ext. int.  
44975H35 41x41x7,5 35,2x35,2x7,5  
44975H50 57x57x9,5 51x51x7,5x9,5







SS

**Insulated container**  
Contentitore isothermico  
Thermobehälter  
Conteneur isotherme  
Contenedor isotérmico

| art.     | Ø cm. | h. cm. | lt. |
|----------|-------|--------|-----|
| 44505-10 | 30    | 22,5   | 10  |
| 44505-15 | 36    | 21,5   | 15  |
| 44505-20 | 36    | 28,5   | 20  |
| 44505-25 | 36    | 35,0   | 25  |



SS

**Insulated container**  
Contentitore isothermico  
Thermobehälter  
Conteneur isotherme  
Contenedor isotérmico

| art.     | Ø cm. | h. cm. | lt. |
|----------|-------|--------|-----|
| 44506-09 | 30    | 34     | 9   |

**Incl. cleaning brush and labels Milk, Coffee and Tea in 5 languages.** – Incl. scovolino, etichette Latte, Caffè e Tè in 5 lingue.



SS

**Food container**  
Pietanziera  
Speisenbehälter  
Porte-manger  
Contenedor comida

| art.     | Ø cm. | h. cm. |
|----------|-------|--------|
| 44977-12 | 12    | 6      |



**Insulated container GN 1/1**  
Contentitore isothermico GN 1/1  
Thermobehälter GN 1/1  
Conteneur isotherme GN 1/1  
Contenedor isotérmico GN 1/1

| art.     | cm.      | lt.  |
|----------|----------|------|
| 44932-15 | 61x41x25 | 24,6 |
| 44932-20 | 61x41x30 | 31,1 |



**Insulated container GN 1/1**  
Contentitore isothermico GN 1/1  
Thermobehälter GN 1/1  
Conteneur isotherme GN 1/1  
Contenedor isotérmico GN 1/1

| art.     | cm.      | lt. |
|----------|----------|-----|
| 44934-30 | 44x64x48 | 63  |



**Insulated beverage dispenser**  
Distributore di bevande isothermico  
Isolierte Getränkebehälter  
Conteneur isotherme avec robinet  
Contenedor isotérmico con grifo

| art.     | cm.      | lt. |
|----------|----------|-----|
| 44930-10 | 24x43x43 | 10  |
| 44930-20 | 30x46x46 | 20  |



PP

**Ice cart**  
Carrello porta ghiaccio  
Eiswagen  
Chariot à glace  
Carro hielo

| art.     | cm.      |
|----------|----------|
| 44936-57 | 72x57x85 |

**Load/Carico: 57 kg.**



PC

**Ice scoop with holder**  
Pala ghiaccio con supporto  
Eisschaufel mit Träger  
Pelle à glace avec support  
Librador hielo con soporte

| art.     | cm.          | lt. |
|----------|--------------|-----|
| 44936-02 | 30,7x20,3x19 | 2   |



PC

**Ice bucket**  
Secchio ghiaccio  
Eiseimer  
Seau à glace  
Cubo hielo

| art.     | cm.      | lt.  |
|----------|----------|------|
| 44936-20 | 34x31x45 | 20,8 |

## JACKSTACK

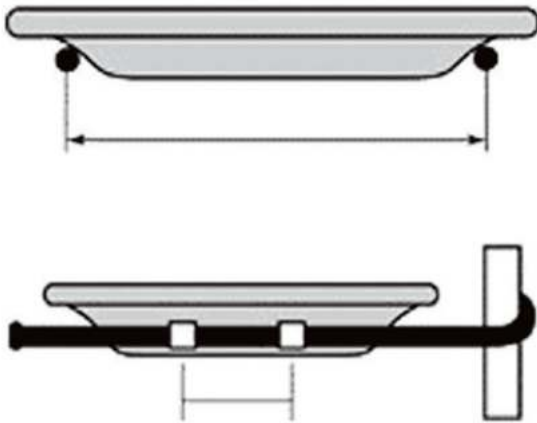

Welded steel construction. Black electrostatic powder coating. Quick set assembly in minutes. Quick-change to any plate size (max ø cm 30, kg 3 each). Length of plate support 17 cm, spacing 5 cm.

Struttura in acciaio saldato. Rivestimento nero elettrostatico. Assemblaggio veloce. Adattabile ad ogni misura di piatto (ø max cm 30, kg 3). Lunghezza bracci 17 cm, distanza 5 cm.



**Mobile plate rack**  
Carrello porta piatti  
Fahrbares Tellergerüst  
Chariot porte-assiettes mobile  
Carrito para almacenaje de platos  
art. cm.  
44830-99 60x60X179

For pcs/Per pz 104

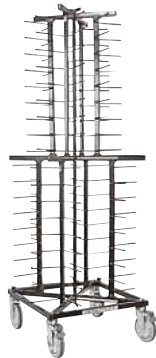

**Mobile plate rack**  
Carrello porta piatti  
Fahrbares Tellergerüst  
Chariot porte-assiettes mobile  
Carrito para almacenaje de platos  
art. cm.  
44830-72 60x60X180

For pcs/Per pz 72



**Mobile plate rack**  
Carrello porta piatti  
Fahrbares Tellergerüst  
Chariot porte-assiettes mobile  
Carrito para almacenaje de platos  
art. cm.  
44830-52 60x60x103

For pcs/Per pz 52



**Swivelling table top rack**  
Porta piatti rotante  
Drehbares Tischgerüst  
Porte-assiettes de table pivotant  
Soporte para almacenaje de platos  
art. cm.  
44831-52 48x48x89

For pcs/Per pz 52



**Zippered plastic cover**  
Copertura in plastica  
Plastik Schutzhülle  
Housse en plastique  
Cubrecarrito, plástico  
art. for/per  
44832-99 44830-72/44830-99



**Thermo cover**  
Copertura termica  
Thermo-Hülle  
Thermo-housse  
Cubrecarrito, térmico  
art. for/per  
44833-99 44830-72/44830-99





**Thermic hot box**

Box termico  
Speisen-Kaste  
Caisson thermique  
Cajón térmico

| art.     | cm.          | W   |
|----------|--------------|-----|
| 44094-00 | 38x40,5x51,2 | 500 |

**Stainless steel box with double insulated wall. Analogic thermostat 30-90°C.**  
Box in acciaio inox a doppia parete coibentata. Termostato analogico 30-90°C.



**Refrigerated box**

Box refrigerato  
Speisen-Kaste  
Caisson réfrigéré  
Cajón refrigerado

| art.     | cm.        |
|----------|------------|
| 44094R00 | 38x40,5x51 |

**Stainless steel box with double insulated wall with chilling pack -32°C.**  
Box in acciaio inox a doppia parete coibentata. Refrigerazione a mezzo di una piastra eutettica -32°C.



**Table with hot box**

Tavolino con box termico  
Tisch mit Hot Box  
Table avec hot box  
Carrito con hot box

| art.     | Ø cm.   | h. cm. | W   |
|----------|---------|--------|-----|
| 44094-02 | 90/54,6 | 77     | 500 |

**Table with fold down flaps. – Tavolo con flaps pieghevoli.**



**Table with hot box**

Tavolino con box termico  
Tisch mit Hot Box  
Table avec hot box  
Carrito con hot box

| art.     | Ø cm.   | h. cm. | W   |
|----------|---------|--------|-----|
| 44094-04 | 90/54,6 | 78,6   | 500 |

**Table with fold down flaps. With capsizable top for stacking when not in use.**  
Tavolo con flaps pieghevoli. Ribaltabile e impilabile quando non in uso.



**Table with hot box**

Tavolino con box termico  
Tisch mit Hot Box  
Table avec hot box  
Carrito con hot box

| art.     | Ø cm. | h. cm. | W   |
|----------|-------|--------|-----|
| 44094-06 | 90/73 | 76     | 500 |

**Table with fold down flaps. Foldable for saving space when not in use. – Tavolo con flaps pieghevoli. Pieghevole per ridurre l'ingombro quando non in uso.**



**Fast food tray**

Vassoio fast food  
Serviertablett, Fast Food  
Plateau fast food  
Bandeja fast food

| art.     | cm.       |
|----------|-----------|
| 41860-36 | 27x36,5   |
| 41860-43 | 30,7x43,5 |
| 41860-47 | 35,5x47   |



PP

**Fast food tray**  
Vassoio fast food  
Serviertablett, Fast Food  
Plateau fast food  
Bandeja fast food

art. cm.  
41861-44 30,7x44



PP

**Gastronorm tray**  
Vassoio Gastronorm  
Serviertablett, Gastronorm  
Plateau Gastronorm  
Bandeja Gastronorm

art. cm. col.  
41862B11 53x32,5x1,6 ●  
41862C11 53x32,5x1,6 ●  
41862G11 53x32,5x1,6 ●



PP

**Euronorm tray**  
Vassoio Euronorm  
Serviertablett, Euronorm  
Plateau Euronorm  
Bandeja Euronorm

art. cm. col.  
41862B53 53x37x1,6 ●  
41862C53 53x37x1,6 ●  
41862G53 53x37x1,6 ●



SS

**Universal tray collector trolley**  
Carrello ritiro vassoi universale  
Tablettabräumwagen Universal  
Chariot débarrassage plateaux universel  
Carro porta bandeja universal

art. cm.  
44803-10 47x55x153  
44803-20 88x55x153

**12 cm between shelves. 4 swivel wheels 100 mm. Chrome-plated steel thread supports 6 mm.**  
Distanza fra piani 12 cm. 4 ruote girevoli 100 mm. Supporti in filetto acciaio cromato 6 mm.



SS

**Universal tray collector trolley**  
Carrello ritiro vassoi universale  
Tablettwagen Universal  
Chariot débarrassage plateaux universel  
Carro porta bandeja universal

art. cm.  
44803-30 129x55x153

**They can hold trays in different sizes (width ranging from 300 to 370 mm) including Euronorm and Gastronorm.** – Possono accogliere vassoi di varia misura (larghezza tra 300 e 370 mm) inclusi Euronorm e Gastronorm.



PP

**Disposable covers, 200 pcs**  
Coperture monouso, 200 pezzi  
Einweg-Schutzhüllen, 200 Stk.  
Housses usage unique, 200 pcs  
Cubrecajitos desechables, 200 pz

art. for/per h. cm.  
42512-91 GN 1/1 180  
42512-92 GN 2/1 180  
60x40 180



SS

**Roll holder**  
Porta rotolo  
Rollenhalter  
Dérouleur mural  
Portarollos

art. cm.  
42512-90 90x23x19



SS

**Utility rack GN 2/1**  
Carrello GN 2/1  
2/1 GN-Behälterwagen  
Chariot GN 2/1  
Carro GN 2/1

art. cm.  
44807-28 60x70x153,5

**Welded structure, 28 rails, 4 wheels, 2 with brakes.** – Struttura saldata, 28 guide, 4 ruote girevoli di cui 2 con freno.



SS

**Utility rack GN 2/1**  
Carrello GN 2/1  
2/1 GN-Behälterwagen  
Chariot GN 2/1  
Carro GN 2/1

art. cm.  
44807-36 73x62x171

**To be assembled, 18 rails, accomodates GN pans height 65 mm. Load max 300 kg.**  
Fornito smontato, 18 guide, accoglie GN di h. 65 mm. Carico max 300 kg.







SS

**Utility rack GN 1/1**

Carrello GN 1/1  
1/1 GN-Behälterwagen  
Chariot GN 1/1  
Carro GN 1/1

art. cm.  
44807-18 38x62x164

**To be assembled, 18 rails, accomodates GN pans height 65 mm. Load max 150 kg.**

Fornito smontato, 18 guide, accoglie GN di h. 65 mm. Carico max 150 kg.



SS

**Utility rack GN 1/1**

Carrello GN 1/1  
1/1 GN-Behälterwagen  
Chariot GN 1/1  
Carro GN 1/1

art. cm.  
44801-09 38x62x94,5

**To be assembled, 9 rails, accomodates GN pans height 65 mm. Load max 75 kg.**

Fornito smontato, 9 guide, accoglie GN di h. 65 mm. Carico max 75 kg.



SS

**Baking sheet trolley**

Carrello porta teglie  
Backbleche-Wagen  
Chariot pour plaques  
Carro porta placas

art. cm.  
44826-00 52x72x85

**Pitch 7,5 cm. For 60x40 cm trays. S/steel top. Swivel castors ø 9.5 cm, 2 with brakes. – Passo 7,5 cm. Per teglie cm 60x40. Piano superiore inox. Ruote piroettanti ø cm 9,5 di cui 2 con freno.**



SS

**Serving trolley**

Carrello di servizio  
Mehrzweckwagen  
Chariot de service  
Carrito para desocupar

art. cm.  
44819-02 91x59x93

**To be assembled, 4 swivel castors, 2 with brakes. Load max 80 kg. – Fornito smontato, 4 ruote girevoli di cui 2 con freno. Carico max 80 kg.**



SS

**Serving trolley**

Carrello di servizio  
Mehrzweckwagen  
Chariot de service  
Carrito para desocupar

art. cm.  
44819-03 91x59x93

**To be assembled, 4 swivel castors, 2 with brakes. Load max 120 kg. – Fornito smontato, 4 ruote girevoli di cui 2 con freno. Carico max 120 kg.**



SS

**Serving trolley**

Carrello di servizio  
Mehrzweckwagen  
Chariot de service  
Carrito para desocupar

art. cm.  
44820-80 80x50x93,5  
44820-99 100x50x93,5

**To be assembled, 4 swivel castors, 2 with brakes. Max load per shelf kg 30.**  
Fornito smontato, 4 ruote girevoli di cui 2 con freno. Portata max. per ripiano kg 30.



SS

**Serving trolley**

Carrello di servizio  
Mehrzweckwagen  
Chariot de service  
Carrito para desocupar

art. cm.  
44822-80 80x50x93,5  
44822-99 100x50x93,5

**To be assembled, 4 swivel castors, 2 with brakes. Max load per shelf kg 30.**  
Fornito smontato, 4 ruote girevoli di cui 2 con freno. Portata max. per ripiano kg 30.



PP

**Serving trolley**

Carrello di servizio  
Mehrzweckwagen  
Chariot de service  
Carrito para desocupar

art. cm.  
44030-03 42x71x90



PP

**Bins and containers**

Cesti e contenitori  
Kasten und Körbe  
Réipients et containers  
Cubos y contenedores

art. cm.  
44031-04 52x39x12,7  
44031-05 52x39x17,7



PE

**Container**  
 Contenitore  
 Kaste  
 Réciptent  
 Contenedor

art. cm.  
 44031-01 33,7x23x56  
 44031-02 33,7x23x18,7



PP

**Serving trolley**  
 Carrello di servizio  
 Mehrzweckwagen  
 Chariot de service  
 Carrito para desocupar

art. cm.  
 49995-04 97x51x99

**Load max 135 kg (45 kg per shelf).**  
 Carico max 135 kg (45 kg per ripiano).



SS

**Minibar restocking cart**  
 Carrello rifornimento frigobar  
 Wagen für Minibar-Versorgung  
 Chariot mini-bar  
 Carro servicio minibar

art. cm.  
 44095-30 73x47x102

**3 PVC boxes with anti-tip cage for 40 bottles ø 6,5 cm max. Castor wheels ø 12,5 cm, 2 with brakes.** – Con 3 cassette in PVC, dotate di gabbia antiribaltamento per 40 bottiglie ø cm 6,5 max. Ruote piroettanti ø cm 12,5 di cui 2 con freno.



**Minibar restocking cart**  
 Carrello rifornimento frigobar  
 Wagen für Minibar-Versorgung  
 Chariot mini-bar  
 Carro servicio minibar

art. cm.  
 44095-32 100x62x119

**Side handle. Key lock. 2 fixed and 2 swivel casters ø 16 cm 2 with brakes.** – Maniglia laterale di spinta. Chiusura con chiave. Ruote ø cm 16, di cui due fisse e due piroettanti con freno.



SS

**Utility rack GN 2/1**  
 Carrello GN 2/1  
 2/1 GN-Behälterwagen  
 Chariot GN 2/1  
 Carro GN 2/1

art. cm.  
 44801-18 73x62x94,5

**To be assembled, 9 rails, accomodates GN pans height 65 mm. Load max 150 kg.**  
 Fornito smontato, 9 guide, accoglie GN di h. 65 mm. Carico max 150 kg.



SS

**Baking sheet trolley**  
 Carrello porta teglie  
 Backbleche-Wagen  
 Chariot pour plaques  
 Carro porta placas

art. cm.  
 44826-20 69x49x187

**20 rails for baking sheets cm 60x40, height clearance 8 cm. Load max 100 kg.**  
 20 guide per teglie cm 60x40, distanza guide 8 cm. Carico max 100 kg.



**Baking sheet trolley, galvanized steel**  
 Carrello porta teglie, zincato  
 Backbleche-Wagen, verzinkt  
 Chariot pour plaques, galvanisé  
 Carro porta placas, galvanizado

art. cm.  
 44825-20 51x50x170

**20 rails, height clearance 8 cm. Load max. 80 kg.**  
 20 guide, distanza guide 8 cm. Carico max 80 kg.



**Baking sheet trolley, galvanized steel**  
 Carrello porta teglie, zincato  
 Backbleche-Wagen, verzinkt  
 Chariot pour plaques, galvanisé  
 Carro porta placas, galvanizado

art. cm.  
 44825-40 51x75x170

**40 rails, height clearance 8 cm. Load max 160 kg.** – 40 guide, distanza guide 8 cm. Carico max 160 kg.



**SS**

**Dolly for cases**

Carrello porta cassette  
Plattformwagen  
Chariot à caisses  
Carretilla de transporte

art. cm.  
44026-60 65x45x12

**Load max 50 kg. – Carico max 50 kg.**



**PE**

**Platform cart**

Carrello trasporto materiali  
Plattformwagen  
Chariot de transport  
Plataforma móvil

art. cm.  
49378-00 82,6x52x98,7

**Three position handle ensures optimum handling whatever the load. Non slip deck, 2 swivel and 2 rigid castors. Load 181 kg. – Maniglia regolabile in 3 posizioni. Superficie antiscivolo. 2 ruote fisse, 2 pivotanti. Carico 181 kg.**



**PP**

**Trolley, convertible**

Carrello convertibile  
Plattformwagen, umwandelbar  
Chariot convertible  
Carretilla convertible

art. cm.  
49379-00 56x53x43,5

**Four non-marking casters (two rear locking), 2 swivel and 2 rigid. – Ruote antitraccia di cui 2 fisse e 2 girevoli, ruote posteriori bloccabili.**





# CLEANING & SAFETY

## PULIZIA & SICUREZZA







PP

**Changing table**

Fasciatoio da parete

Windeln-Tisch

Table à langer

Mesa cambia-pañales

art. cm.

49336-00 91x71x49,6

49336-02 60x88x48

**Rated for continuous use up to 23 kg. – Portata max in uso 23 kg.**



PP

**Sturdy chair**

Seggiolone

Kinderstuhl

Chaise d'enfant

Silla niños

art. cm.

49337-00 60x60x75,5

49337-01 29x47x8,3

**For children up to 3 years old or 18 kg weight. With Microban antimicrobial protection. – Adatto a bambini fino a 3 anni o 18 kg di peso. Con protezione antibatterica in Microban.**



W

**Sturdy chair**

Seggiolone

Kinderstuhl

Chaise d'enfant

Silla niños

art. cm. col.

49335-01 50x50x75 ●

49335-02 50x50x75 ●

**Suitable for children from 6 months to 3 years. Max 20 kg. Solid and sturdy, built with rubber tree wood, respecting the environment. Wide base for greater stability. Easy to assemble. Stackable to save space. Supplied with seat belts and safety buckle. – Adatto ai bambini da 6 mesi a 3 anni. Fino a 20 kg. Solido e robusto, costruito con legno di albero della gomma, in rispetto dell'ambiente. Base larga per una maggiore stabilità. Facile da montare. Impilabile per risparmiare spazio. Fornito con cinture e fibbia di sicurezza.**



**Trolley Quick Cart**

Carrello Quick Cart

Quick Cart-Wagen

Chariot Quick Cart

Carretilla Quick Cart

art. cm. Kg. cap. m3

44178-01 42x36x43 6,5 0,05

44178-02 42x36x53 7,0 0,06

**Versatile compartments allow for multiple configurations and uses. Removable caddy. Adjustable dividers. Teflon fabric protector, repels water, oil and stains. Reinforced rubberised kick plate. – Scomparti versatili consentono molteplici configurazioni e usi. Cestello estraibile. Divisori removibili. Rivestimento in Teflon, respinge acqua, olio e macchie. Scocca rinforzata in gomma.**



**Collapsible frame, powder coated steel**

Telaio pieghevole, acciaio verniciato

Klappbares Gestell, pulverbeschichtete Stahl

Châssis repliable, acier peint

Carre plegable, acero pintado

art. cm. lt.

44178-15 51,5x61x84 150

44178-16 89x61x84 300

**Collapsible frame enables efficient storage. Compact, lightweight design for superior manoeuvrability. Remains collapsible with or without cover. – Telaio pieghevole consente uno stoccaggio efficiente. Design compatto e leggero per una maggiore manovrabilità. Rimane pieghevole con o senza copertura.**





**Vinyl bag, black**

Sacco vinile, nero  
Vinyl-Sack, schwarz  
Sac en vinyle, noir  
Bolsa de vinilo, negro

| art.     | cm.      | lt. |
|----------|----------|-----|
| 44178-17 | 39x57x69 | 150 |
| 44178-18 | 78x57x69 | 300 |

**Durable, high capacity (100 kg) vinyl bag accommodates large loads; easy-to-clean.** – Sacchi in vinile durevoli, ad alta capacità (100 kg); facili da pulire.



**Vinyl bag cover, black**

Copertura vinile, nero  
Vinyl-Sack-deckel, schwarz  
Couvercle à sac en vinyle, noir  
Tapa para bolsa de vinilo, negro

| art.     | cm.      |
|----------|----------|
| 44178-19 | 64x50x23 |
| 44178-20 | 89x66x23 |

**Multiple, built-in storage pockets on each side. Convenient, Quick-Access-Lid provides easy access to contents inside of cart without having to remove cover.** – Con tasche integrate su ogni lato. Comodo, accesso rapido all'interno del carrello, senza dover rimuovere il coperchio.



PP

**Service trolley**

Carrello di servizio  
Servicewagen  
Chariot de service  
Carro de habitaciones

| art.     | cm.        | lt.     | Kg.  |
|----------|------------|---------|------|
| 44174-24 | 177x58x107 | 120+120 | 26,4 |

**Wheels ø 125 mm, 2 bag holders + 2 bags lt 120. Made in PP copolymer.**  
Ruote ø 125 mm, 2 portasacchi pieghevoli + 2 sacchi lt 120. Prodotto in PP copolimero.



PP

**Service trolley**

Carrello di servizio  
Servicewagen  
Chariot de service  
Carro de habitaciones

| art.     | cm.        | lt. | Kg. |
|----------|------------|-----|-----|
| 44177-12 | 104x56x130 | 150 | 26  |

**Frame in tubular steel rilsan coated. Wheels ø 125 mm. 3 wooden shelves 50x46 cm. Bag holder + canvas bag polyester 55x55x94 cm.**  
Montanti in tubolare inox verniciato rilsan. Ruote ø 125 mm. 3 ripiani legno 50x46 cm. Portasacchi+sacchi in tela poliestere 55x55x94 cm.



PP

**Housekeeping cart for linen collection**

Carrello portabiancheria  
Hotelwäschewagen  
Chariot d'étage à linge  
Carro de recogida de ropa

| art.     | cm.        | lt. | Kg.  |
|----------|------------|-----|------|
| 44176-30 | 105x55x105 | 300 | 12,5 |

**Frame in tubular steel rilsan coated. Wheels ø 125 mm. Nylon bag.** – Montanti in tubolare inox verniciato rilsan. Ruote ø 125 mm. Sacco in nylon plastificato.



**Housekeeping cart for linen collection**

Carrello portabiancheria  
Hotelwäschewagen  
Chariot d'étage à linge  
Carro de recogida de ropa

| art.     | cm.       | lt. | Kg.  |
|----------|-----------|-----|------|
| 44175-15 | 62x60x103 | 150 | 6,39 |

**Capacious canvas bag laminated washable at 30°C. Folding frame. Swivel casters ø 80 mm.** – Capiente sacco in tela plastificata lavabile a 30°C. Telaio pieghevole. Ruote piroettanti ø 80 mm.





**Cleaning system, Pulse**

Sistema di pulizia, kit Pulse  
Reinigungssystem Pulse  
Système de nettoyage Pulse  
Sistema de limpieza Pulse

art. cm.  
44151-00 12,4x9,5x142

**Aluminum frame 40 cm and 2 microfibre mops. On-board reservoir 700 ml that allows to clean up to 80 sqm.**

Telaio in alluminio con velcro da 40 cm, 2 mop in microfibra. Dotato di deposito integrato da 700 ml che permette di pulire fino a 80 mq.



**Microfibre mops**

Mop in microfibra  
Microfibr-Mops  
Franges en microfibre  
Fregadoras de microfibra

| art.     | cm.   | des.        | U. Pack |
|----------|-------|-------------|---------|
| 44151-AA | 40x14 | Wet         | 10      |
| 44151-AB | 40x14 | High absorb | 10      |
| 44151-AC | 40x14 | Scrubber    | 10      |

**Wet use, high absorbency, for 80 sqm. Launderable up to 500 times (200 with bleach) at high water temperature.** – Uso umido ad elevata assorbenza 80 mq. Ciclo di vita: 500 lavaggi (200 con candeggina) ad elevate temperature.



**Dust beater V sweeper**

Scopa a forbice  
Doppel-Wischmop  
Balai double mop  
Escoba doble

art. h. cm.  
44160-03 135

**Opening angle 140° about. Cotton mops length 100 cm.** – Apertura 140° circa. Frange in cotone 100 cm.



**Mechanical sweeper**

Aspirapolvere meccanico  
Kehrer mit mechanischem Antrieb  
Balai mécanique  
Escoba mecánica

art. cm. lt.  
44150-19 28,5x25x102 0,6

**ABS and galvanised steel construction. Ideal for hard floors and low pile carpets. Sweeping path 19 cm.** – ABS e acciaio galvanizzato. Ideale sia per tappeti/moquette a pelo corto che per pavimenti. Battuta 19 cm.



**Broom + dust pan**

Scopa + alza immondizia  
Kehrset mit Stiel und Schmutzcontainer  
Balai + pelle  
Escoba + recogedor

art. cm.  
44149-03 28,6x13x32,5

**Self opening and closing lid. Broom hanger bracket.** – Porta immondizia con coperchio. Staffa di supporto per scopa.

PP



**Dustpan**

Pattumiera  
Müllschaufel  
Pelle à poussière  
Pala

art. cm.  
44170-00 29x28x87,5

**Shock-proof plastic material, equipped with a rubber blade that adheres perfectly to the floor. Aluminium handle.** – Materiale plastico antiurto, dotata di una lamina di rifinitura in gomma che aderisce perfettamente al pavimento.

PP



**Broom, aluminum rod**

Scopa, manico alluminio  
Besen mit Alustiel  
Balai, manche alu  
Escoba, mango alumínio

art. h. cm.  
44170-01 80

**To use in combination with the handy dustpan thanks to its ergonomic grip with handle holder.** Da utilizzarsi abbinata alla pattumiera, a cui può essere agganciata tramite l'attacco portamanico.

PP



**Cleaning wand**

Scopa spingiacqua  
Abzieher  
Balai raclette  
Jalador de agua

art. cm.  
44148-01 116,8x40

**Blade made of soft double mass squeegee foam supported by a galvanized metal frame.** Testa della scopa realizzata in morbida gommaspugna a doppio strato sostenuta da telaio in metallo galvanizzato.



**Wet mop handles**

Manico per mop  
Nassmopp-Stiele  
Supports pour franges  
Mangos para fregonas

| art.     | cm.   | col. |
|----------|-------|------|
| 44141-01 | 152,4 | ●    |
| 44141-03 | 152,4 | ●    |

**Polypropylene/Glass fiber.** Polipropilene/fibra di vetro.



**Cotton-end string mop**

Mop a strisce in cotone  
Spaghetti-Mop mit Baumwollenend  
Frange à ficelles en coton  
Mopa de algodón

| art.     | gr. |
|----------|-----|
| 44142-40 | 400 |



**Cotton mop rod, screw fitting**

Manico per mop, attacco filettato  
Mop-Stange mit Schraubanschluss  
Manche pour mop avec attache à vis  
Mango para fregadora, conexión tornillo

| art.     | Ø cm. | cm. |
|----------|-------|-----|
| 44167-13 | 2,2   | 130 |

**Red lacquered iron. Lightweight and rustproof.**  
Ferro verniciato rosso. Leggero ed inossidabile.



**Cotton mop, screw fitting**

Mop in cotone, attacco filettato  
Baumwollmop mit Schraubanschluss  
Mop en coton avec attache à vis  
Mopa de algodón

| art.     | gr. |
|----------|-----|
| 44166-28 | 280 |



**Telescopic rod**

Manico telescopico  
Teleskopstange  
Manche telescopique  
Mango telescópico

| art.     | Ø cm. | cm.    |
|----------|-------|--------|
| 44161-00 | 2,3   | 97>184 |

**Two-piece anodized aluminum rod.**  
Alluminio anodizzato due pezzi.



**Mop holder**

Pinza per mop  
Wischmophalter  
Pince faubert  
Pinza

| art.     |
|----------|
| 44164-00 |

**Universal ring allows the use of any handle with from ø 20 to 24 mm. – Ghiera universale consente l'utilizzo di qualsiasi manico con ø 20>24 mm.**



**Cotton-end string mop**

Mop a strisce in cotone  
Spaghetti-Mop mit Baumwollenend  
Frange à ficelles en coton  
Mopa de algodón

| art.     | gr. |
|----------|-----|
| 44165-35 | 350 |
| 44165-40 | 400 |
| 44165-50 | 500 |



**Microfibre cloth, 12 pcs**

Panno in microfibra, 12 pz  
Mikrofasertuch, 12 Stk  
Carré en microfibre, 12 pcs  
Paño de microfibra, 12 pz

| art.     | cm.       | col. |
|----------|-----------|------|
| 44147-00 | 40,6x40,6 | ●    |
| 44147-01 | 40,6x40,6 | ●    |
| 44147-02 | 40,6x40,6 | ●    |
| 44147-03 | 40,6x40,6 | ●    |

**Launderable up to 100 times with bleach and 250 without bleach. – Dura 100 lavaggi con candeggina e 250 senza.**



**Floor sign, 2-sided**

Cavalletto segnalazione a 2 lati  
Warnschild, 2-seitig  
Panneau d'avertissement 2 côtés  
Señal de suelo 2 lados

| art.     | h. cm. |
|----------|--------|
| 44077-00 | 57     |
| 44077-CC | 67     |

PP



**Safety chain for floor signs**

Catenella di sicurezza per cavalletti  
Kunststoff-Kette für Warnschilder  
Chaîne de sécurité pour panneaux de sol  
Cadena plástica para señales de suelo

| art.     | cm. |
|----------|-----|
| 44077-06 | 600 |

**To link floor signs or safety cones together to create an effective barrier system for hazardous areas. – Per collegare cavalletti e coni di segnalazione e creare un sistema di delimitazione delle aree pericolose.**







**Telescopic door sign**

Segnalatore telescopico di sicurezza  
Teleskop-Sicherheitstürschild  
Panneau de sécurité télescopique  
Señal de seguridad telescópico

art. cm.

44077-10 63,5x2,5x33

**Aluminium/Vinyl. Width open 112 cm. Extendable pole to block out doorways and entrances.**

Alluminio/Vinile. Larghezza aperto 112 cm. Palo estensibile per bloccare porte e ingressi.



**Multi-purpose trolley**

Carrello multiuso  
Allzweckwagen  
Chariot multi-usage  
Carro de limpieza

art. cm.

44173-00 97x68x111

**Bag holder with cover, bag lt. 120, pan with hooks, 2 buckets 4 lt. and 2 buckets 15 lt., wringer.** – Portasacco con cop., sacco lt. 120, vaschetta con ganci, 2 secchi 4 lt., 2 secchi 15 lt., strizzatore.



**Mopping trolley with press**

Carrello lavapavimenti con strizzatore  
Wringer Reinigungswagen mit Presse  
Chariot de ménage avec presse  
Carro con prensa escurridora

art. cm.

44171-24 62x42x90

**Wringer and 25 lt. bucket. With storage compartment. PSV reinforced handle.**

Strizzatore e 1 secchio lt. 25. Vano portaoggetti. Impugnatura in PSV completa di rinforzi.



**Mopping trolley with press**

Carrello lavapavimenti con strizzatore  
Wringer Reinigungswagen mit Presse  
Chariot de ménage avec presse  
Carro con prensa escurridora

art. cm.

44171-50 69x42x90

**Wringer and 2 buckets lt. 25 each. Painted handle, reversible.** – Strizzatore e 2 secchi da lt. 25. Impugnatura verniciata, reversibile.



**Mopping trolley with press**

Carrello lavapavimenti con strizzatore  
Wringer Reinigungswagen mit Presse  
Chariot de ménage avec presse  
Carro con prensa escurridora

art. cm.

44172-30 47x40x93

**Single tank with wringer.**  
Monovasca con strizzatore.



**Graduated bucket**

Secchio graduato  
Eimer mit Skala  
Seau gradué  
Cubo con medidas

art. cm. lt. col.

44169B06 24x19x21,5 6 ●

44169R06 24x19x21,5 6 ●



**Graduated bucket**

Secchio graduato  
Eimer mit Skala  
Seau gradué  
Cubo con medidas

art. cm. lt. col.

44169B14 34x33,5x28 15 ●

44169R25 37x36,5x32 25 ●



**Bucket with wringer**

Secchio con strizzatore  
Eimer mit Presse  
Seau avec essoreur  
Cubo con prensa

art. cm. lt.

44168-12 35x27x29,5 12

**With graduated scale 0-12 lt.**  
Scala graduata 0-12 lt.



**Waste container**

Cestino  
Abfallbehälter  
Collecteur  
Papelera

art. Ø cm. h. cm. lt.

44097-00 30 31,5 15,9



**Waste container SLIM JIM**

Contentore rifiuti  
Abfallbehälter  
Collecteur  
Colector

| art.     | cm.      | lt. |
|----------|----------|-----|
| 49931-60 | 59x28X63 | 60  |
| 49931-87 | 56x28X76 | 87  |



**Hinged lid**

Coperchio ancorato  
Klapp-Deckel  
Couvercle à charnière  
Tapa abatible

| art.     | cm.       |
|----------|-----------|
| 49931-00 | 55,6x34x3 |

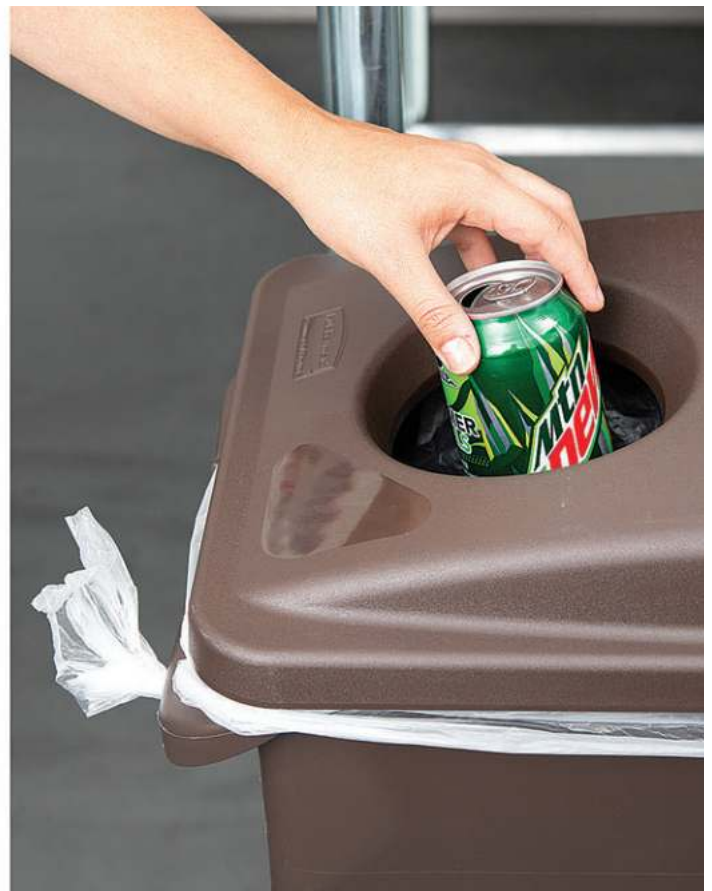

**Lid**

Coperchio  
Deckel  
Couvercle  
Tapa

| art.     | cm.     | col. |
|----------|---------|------|
| 49931A00 | 52x29x7 | ●    |
| 49931C04 | 52x29x7 | ●    |
| 49931B05 | 52x29x7 | ●    |
| 49931B02 | 52x29x7 | ●    |
| 49931B03 | 52x29x7 | ●    |
| 49931B01 | 52x29x7 | ●    |



**Dolly SLIM JIM**

Carrello  
Transportwagen  
Chariot  
Carrito

| art.     | cm.          |
|----------|--------------|
| 49931-64 | 60,6x37,4X21 |

**Side clip allows to tow together more trolleysdal release fast and simple. –** Aggancio laterale a clip che permette di trainare insieme diversi carrelli. Rilascio a pedale semplice e veloce.





**PE**

**Step on bin**  
Pattumiera a pedale  
Pedaleimer  
Poubelle à pédale  
Colector a pedal

| art.     | cm.        | lt. |
|----------|------------|-----|
| 49933-30 | 50x31x56,5 | 30  |
| 49933-50 | 53x34x72   | 50  |
| 49933-68 | 56x37x78   | 68  |



**PE**

**Mobile pedal bin**  
Pattumiera a pedale  
Pedaleimer  
Poubelle à pédale  
Colector a pedal

| art.     | cm.      | lt. |
|----------|----------|-----|
| 44095-12 | 48x55x93 | 120 |

**Certified UNI EN 840. Withstanding chemical, can be washed and sterilized.** – Certificata UNI EN 840. Resistente agli agenti chimici, lavabile e sterilizzabile.



**PP**

**Mobile pedal bin**  
Pattumiera a pedale  
Pedaleimer  
Poubelle à pédale  
Colector a pedal

| art.     | cm.      | lt. |
|----------|----------|-----|
| 44095-18 | 40x65x81 | 80  |



**PP**

**Mobile pedal bin**  
Pattumiera a pedale  
Pedaleimer  
Poubelle à pédale  
Colector a pedal

| art.     | cm.      | lt. | col. |
|----------|----------|-----|------|
| 44096-80 | 48x50x78 | 80  | ○    |
| 44096B80 | 48x50x78 | 80  | ●    |
| 44096Y80 | 48x50x78 | 80  | ●    |
| 44096R80 | 48x50x78 | 80  | ●    |
| 44096G80 | 48x50x78 | 80  | ●    |



**Refuse bag holder trolley**  
Carrello portasacco  
Sackhalterwagen  
Chariot porte-sac  
Colector móvil

| art.     | cm.       | lt. |
|----------|-----------|-----|
| 44089-12 | 58x56x102 | 120 |

**Coated iron foldable frame. Round bag holder, pirouetting wheels Ø 80 mm.** – Telaio pieghevole in acciaio verniciato. Portasacco rotondo. Ruote piroettanti Ø 80 mm.



**PP**

**Mobile pedal bin, fire-proof**  
Pattumiera a pedale, ignifuga  
Pedaleimer, feuersicher  
Poubelle à pédale, ignifugée  
Colector a pedal, ignífugo

| art.     | cm.      | lt. | col. |
|----------|----------|-----|------|
| 49899-01 | 46x32x80 | 70  | ●    |

**Mechanical parts in stainless steel. The lid can be removed.** – Parti meccaniche in acciaio inox. Coperchio staccabile.



**PP**

**Pedal bin lids**  
Coperchi pattumiera  
Pedaleimer-Deckel  
Couvercles poubelle  
Tapas para colector

| art.     | cm.   | col. |
|----------|-------|------|
| 49899-91 | 46x32 | ●    |
| 49899-92 | 46x32 | ●    |
| 49899-93 | 46x32 | ●    |
| 49899-94 | 46x32 | ●    |
| 49899-95 | 46x32 | ●    |



**PE**

**Tilt truck**  
Benna ribaltabile  
Fallen Eimerwagen  
Benne  
Carrito plegable

| art.     | cm.        | lt. | Kg. |
|----------|------------|-----|-----|
| 49934-04 | 145x68x86  | 400 | 205 |
| 49934-06 | 164x77x97  | 600 | 272 |
| 49934-08 | 180x85x107 | 800 | 570 |





PE

**Domed linged lid**

Coperchio a doppia apertura  
Doppel-Deckel  
Couvercle double  
Tapa doble

| art.     | cm.       |
|----------|-----------|
| 49934-14 | 132x71x23 |
| 49934-16 | 155x81x23 |
| 49934-18 | 169x87x23 |



PP

**Folding ladder**

Scaletta pieghevole  
Klappleiter  
Marche-pied pliable  
Escalera plegable

| art.     | cm.        |
|----------|------------|
| 49378-48 | 48,6x17x63 |

**Load 150 kg. Resists from 0 to 50 °C.**  
Carico 150 kg. Resiste da 0 a 50°C.



PE

**Pallet**

Pallet  
Pallet  
Palette  
Racks para suelos

| art.     | cm.       | Kg. |
|----------|-----------|-----|
| 49373-05 | 80x120x14 | 4,6 |

**Static load 1000 kg. Appropriate for food.**  
Carico statico 1000 kg. Per uso alimentare.



**Dunnage rack**

Pedana  
Lageruntersätze  
Palettes  
Bancada

| art.     | cm.          | load kg |
|----------|--------------|---------|
| 49371-09 | 91,4x56x30,5 | 68      |
| 49371-12 | 122x56x30,5  | 136     |

**Rust and corrosion-proof polymer material.**  
Materiale polimerico resistente alla ruggine e alla corrosione.



SS

**Floor standing ashtray**

Posacenere a colonna  
Standascher/Abfalleimer  
Cendrier sur pied  
Contenedor con cenicero

| art.     | Ø cm. | h. cm. |
|----------|-------|--------|
| 49897-09 | 9     | 86     |



SS

**Standing ashtray/bin**

Posacenere/pattumiera  
Standascher/Abfalleimer  
Cendrier/poubelle  
Cenicero/papelera

| art.     | Ø cm. | h. cm. |
|----------|-------|--------|
| 49898-30 | 30    | 60     |



PP

**Standing ashtray**

Posacenere/fioriera  
Standascher  
Cendrier sur pied  
Cenicero

| art.     | Ø cm. | h. cm. |
|----------|-------|--------|
| 49892-40 | 40    | 60     |

**Included bag of sand 1,5 kg.**  
Incl. sacchetto sabbia kg 1,5.





## RETRACTABLE BARRIERS ASTE DELIMITA CORSIE

Tubular structure in stainless steel matte finish or black lacquered  $\varnothing$  63 mm, thickness 0,8 mm. 4-way retractable polyester black belt length 2,13 meters, width 4,8 cm. Ballasted base  $\varnothing$  cm 31 with rubber under the base. Weight 10 kg. Overall height 1 mt. Possibility to apply landscape display.

Struttura tubolare in acciaio inossidabile finitura satinata o laccata nera  $\varnothing$  63 mm, spessore 0,8 mm. Nastro retrattile 4-vie in poliestere nero lunghezza 2,13 metri, larghezza 4,8 cm. Base zavorrata  $\varnothing$  31 cm con gomma sotto la base. Peso 10 kg. Altezza totale 1 mt. Possibilità di applicare tabella segnaletica.



### Retractable barrier set

Set aste delimita corsie a nastro estensibile  
Absperrpfost mit einziehbarer Gurt, 2 Stk  
Set poteaux avec ceinture rétractable  
Juego de columnas móviles con cinta retráctil

| art.     | $\varnothing$ cm. | base $\varnothing$ cm. | belt/nastro | h. cm. | Kg. |
|----------|-------------------|------------------------|-------------|--------|-----|
| 44183-01 | 6,3               | 36                     | cm 213x4,8  | 100    | 10  |

**Black laquered.** – Laccato nero.



### Retractable barrier set

Set aste delimita corsie a nastro estensibile  
Absperrpfost mit einziehbarer Gurt, 2 Stk  
Set poteaux avec ceinture rétractable  
Juego de columnas móviles con cinta retráctil

| art.     | $\varnothing$ cm. | base $\varnothing$ cm. | belt/nastro | h. cm. | Kg. |
|----------|-------------------|------------------------|-------------|--------|-----|
| 44184-01 | 6,3               | 36                     | cm 213x4,8  | 100    | 10  |

**Stainless steel matt finish.** – Inox finitura satinata.



### Post top sign holder

Tabella  
Posterhalter  
Porte-enseigne  
Cartelera

| art.     | cm.    |
|----------|--------|
| 44183-A4 | DIN-A4 |
| 44183-A3 | DIN-A3 |

**Black laquered.** – Laccato nero.



### Post top sign holder

Tabella  
Posterhalter  
Porte-enseigne  
Cartelera

| art.     | cm.    |
|----------|--------|
| 44184-A4 | DIN-A4 |
| 44184-A3 | DIN-A3 |

**Stainless steel matt finish.** – Inox finitura satinata.



# ELECTRIC APPLIANCES APPARECCHI ELETTRICI





**Dualit.**

**4 slot toaster**

Tostapane 4 fette  
Brotröster  
Grille pain  
Tostadora

| art.     | cm.      | Kg.  | kW  |
|----------|----------|------|-----|
| 49801-04 | 36x21x22 | 4,25 | 2,2 |



**Dualit.**

**6 slot toaster**

Tostapane 6 fette  
Brotröster  
Grille pain  
Tostadora

| art.     | cm.      | Kg. | kW |
|----------|----------|-----|----|
| 49801-06 | 46x21x22 | 5,1 | 3  |



**Dualit.**

**4 slice bun toaster**

Tostapane 4 fette  
Brotröster  
Grille pain  
Tostadora

| art.     | cm.      | Kg.  | kW |
|----------|----------|------|----|
| 49802-04 | 36x21x22 | 4,52 | 1  |



**Dualit.**

**6 slice bun toaster**

Tostapane 6 fette  
Brotröster  
Grille pain  
Tostadora

| art.     | cm.      | Kg.  | kW  |
|----------|----------|------|-----|
| 49802-06 | 46x21x22 | 5,52 | 1,5 |



**Conveyor Toaster**

Tostapane a nastro  
Durchlauf-Toaster  
Toaster convoyeur  
Tostador a túnel

| art.     | cm.      | Kg. | kW  |
|----------|----------|-----|-----|
| 49803-02 | 37x64x40 | 20  | 2,8 |



**Conveyor toaster, CT540 B**

Tostapane a nastro doppia uscita  
Durchlauf toaster  
Toaster convoyeur  
Tostador a túnel

| art.     | cm.        | Kg. | kW   |
|----------|------------|-----|------|
| 49850-20 | 50x68x34,5 | 20  | 2,65 |



**Toaster, BAR 1000**

Tostapane  
Toast-/Überbackgerät  
Toaster  
Tostador de pan

| art.     | cm.          | Kg. | kW |
|----------|--------------|-----|----|
| 49850-65 | 45x28,5x30,5 | 10  | 2  |



**Contact grill, SAVOYE**

Grill a contatto  
Kontaktgrill  
Grill à contact  
Grill de contacto

| art.     | cm.        | Kg. | kW |
|----------|------------|-----|----|
| 49850-22 | 33x38,5x22 | 18  | 2  |





**Contact grill, PANINI**

Grill a contatto  
Kontaktgrill  
Grill à contact  
Grill de contacto

| art.     | cm.        | Kg.  | kW |
|----------|------------|------|----|
| 49850-21 | 43x38,5x22 | 22,5 | 3  |

**Contact grill double plate, MAJESTIC**

Grill a contatto doppia piastra  
Kontaktgrill, 2 Platten  
Grill à contact, 2 plaques  
Grill de contacto doble

| art.     | cm.        | Kg.  | kW  |
|----------|------------|------|-----|
| 49850-23 | 60x38,5x22 | 33,5 | 2x2 |

**Dualit.****Contact sandwich toaster**

Grill a contatto  
Sandwich-Toaster  
Appareil croque monsieur  
Grill de contacto

| art.     | cm.      | Kg. | kW  |
|----------|----------|-----|-----|
| 49806-00 | 40x22x19 | 6   | 1,6 |

**Contact grill, PANINI XL**

Grill a contatto  
Kontaktgrill  
Grill à contact  
Grill de contacto

| art.     | cm.      | Kg. | kW  |
|----------|----------|-----|-----|
| 49850-19 | 41x62x34 | 32  | 3,6 |

**Glas ceramic contact grill, GVS 335**

Grill a contatto vetroceramica  
Kontaktgrill, Glaskeramik-Platte  
Grill à contact vitrocéramique  
Grill de contacto vitrocerámica

| art.     | cm.      | Kg. | kW |
|----------|----------|-----|----|
| 49850-18 | 39x60x26 | 14  | 3  |

**Salamander, SEM 600 PDS**

Salamandra  
Salamanders mit PDS  
Salamandre avec détection de plat  
Salamandra con PDS

| art.     | cm.      | Kg. | kW |
|----------|----------|-----|----|
| 49850-71 | 60x64x59 | 56  | 3  |







**Hot dog heater, CS 3 E**

Scalda würstel  
Würstchenwärmer  
Chauffe-saucisses  
Calentador de salchichas

| art.     | cm.      | Kg. | kW   |
|----------|----------|-----|------|
| 49850-61 | 44x30x40 | 9   | 0,65 |



**Kebab/Gyros grill, GR 40 E**

Griglia kebab/gyros  
Elektro-Dönergrill  
Gril à kebab/gyros  
Asador de kebab/gyros

| art.     | cm.        | Kg. | kW  |
|----------|------------|-----|-----|
| 49850-13 | 58x66x69,5 | 15  | 3,6 |



**Kebab/Gyros grill, GR 60 E**

Griglia kebab/gyros  
Elektro-Dönergrill  
Gril à kebab/gyros  
Asador de kebab/gyros

| art.     | cm.      | Kg. | kW  |
|----------|----------|-----|-----|
| 49850-14 | 58x66x87 | 25  | 5,8 |



**Crepe machine, high-capacity, CFE 400**

Crepiera tonda, ad alto rendimento  
Crêpegerät  
Crêpière à haut rendement  
Crepera

| art.     | Ø cm. | h. cm. | Kg. | kW  |
|----------|-------|--------|-----|-----|
| 49850-33 | 40    | 20     | 18  | 3,6 |



**Double crepe machine, CDE 400**

Crepiera doppia  
Crêpegerät, 2 Platten  
Crêpière double  
Crepera 2 placas

| art.     | Ø cm. | cm.      | Kg. | kW  |
|----------|-------|----------|-----|-----|
| 49850-11 | 40    | 45x50x24 | 23  | 3,6 |



**Eggs boiler, CO 60**

Bollitore uova  
Eierkocher  
Cuiseur à oeuf  
Caldera para huevos

| art.     | cm.          | Kg. | kW  |
|----------|--------------|-----|-----|
| 49850-36 | 21,5x43x25,5 | 4,5 | 1,2 |



**Multifunction oven, FC 280**

Forno multifunzione  
Multifunktionsofen  
Four multifonctions  
Horno multifunción

| art.     | cm.        | Kg. | kW  |
|----------|------------|-----|-----|
| 49850-73 | 46x55x35,5 | 20  | 1,5 |

**Multifunction oven, FC 380 TQ**

Forno multifunzione  
Multifunktionsofen  
Four multifonctions  
Horno multifunción

| art.     | cm.        | Kg. | kW  |
|----------|------------|-----|-----|
| 49850-75 | 55x55x35,5 | 22  | 2,4 |

**Multifunction oven, FC 60 TQ**

Forno multifunzione  
Multifunktionsofen  
Four multifonctions  
Horno multifunción

| art.     | cm.        | Kg. | kW |
|----------|------------|-----|----|
| 49850-76 | 59,5x61x59 | 38  | 3  |

**Fryer, FD 80 R**

Friggitrice  
Fritteuse  
Friteuse  
Freidora

| art.     | cm.        | kg./H | Kg. | kW  |
|----------|------------|-------|-----|-----|
| 49850-41 | 26,5x45x36 | 15    | 8   | 3,6 |

**Fryer, FD 80 DR**

Friggitrice  
Fritteuse  
Friteuse  
Freidora

| art.     | cm.      | kg./H | Kg. | kW    |
|----------|----------|-------|-----|-------|
| 49850-42 | 59x45x37 | 30    | 15  | 2x3,6 |

**Fryer, FD 50**

Friggitrice  
Fritteuse  
Friteuse  
Freidora

| art.     | cm.          | kg./H | Kg. | kW  |
|----------|--------------|-------|-----|-----|
| 49850-37 | 21,5x42,5x32 | 10    | 5   | 3,2 |





**Dish-warmer, DW106 / 110**

Scaldapiatti  
Rechaud  
Chauffe plats  
Calentador de platos

| art.     | cm.          | Kg. | kW   |
|----------|--------------|-----|------|
| 49850-06 | 40x21,5x33,5 | 14  | 0,65 |
| 49850-10 | 40x21,5x47,5 | 25  | 1,3  |



**Ventilated warming display, WD 780 DI**

Espositore caldo ventilato  
Konvektion-Warme Theke  
Présentoir chaud à convection  
Expositor caliente con convección

| art.     | cm.      | Kg. | kW  |
|----------|----------|-----|-----|
| 49850-70 | 78x49x64 | 35  | 1,8 |



**Warming display**

Vetrina riscaldata  
Warmhalte-Vitrine  
Vitrine chauffante  
Vitrina caliente

| art.     | GN  | cm.        | Kg. | kW   | range     |
|----------|-----|------------|-----|------|-----------|
| 49850-43 | 1/1 | 59x35x28,5 | 12  | 0,65 | +20 +95°C |



**Warming display**

Vetrina riscaldata  
Warmhalte-Vitrine  
Vitrine chauffante  
Vitrina caliente

| art.     | GN     | cm.      | Kg. | kW   | range     |
|----------|--------|----------|-----|------|-----------|
| 49850-44 | 2x 1/1 | 59x35x39 | 15  | 0,65 | +20 +95°C |



**Tapas display**

Vetrina antipasti  
Vorspeisen-Schaufenster  
Vitrine tapas  
Vitrina para tapas

| art.     | cm.       | Kg. | W   | range   |
|----------|-----------|-----|-----|---------|
| 49630-06 | 145x40x26 | 33  | 160 | +2/+5°C |



**Ice cream maker**

Macchina per gelato  
Eismaschine  
Machine à glace  
Maquinas helado

| art.     | cm.      | lt. | kg./H | Kg. | kW  |
|----------|----------|-----|-------|-----|-----|
| 49949-19 | 51x31x35 | 1,5 | 3     | 30  | 0,4 |



**Dehydrator for fruits and vegetables**

Disidratatore per frutta e verdura  
Dehydratisierapparat  
Déshydrateur fruits et légumes  
Deshidratador de frutas y verduras

| art.     | cm.        | Kg. | kW   | range     |
|----------|------------|-----|------|-----------|
| 49953-02 | 43,5x29x21 | 3,6 | 0,53 | +30 +80°C |

**Supplied with 6 reversible trays. Timer up to 72 hours.**  
6 vassoi reversibili. Timer fino a 72 ore.

**Smoker, 2 levels**

Affumicatoio a 2 piani  
Räucherofen  
Fumoir  
Ahumador

| art.     | cm.      | Kg. | kW  |
|----------|----------|-----|-----|
| 49850-63 | 45x45x35 | 25  | 1,5 |

**Table-top cutter**

Cutter da tavolo  
Gemüseschneidmaschine  
Cutter à légumes  
Cortador verduras

| art.     | cm.      | lt. | Kg. | V           |
|----------|----------|-----|-----|-------------|
| 49979-03 | 32x52x62 | 3   | 12  | 115-220-240 |

**Single phase. Anodised aluminium, s/s container and blades, transparent lid.**  
Monofase. Alluminio anodizzato, contenitore e lame inox, coperchio trasparente.

**Electric peeler**

Pelatrice elettrica  
Elektr. Schälmachine  
Eplucheur électrique  
Pelador eléctrico

| art.     | cm.        | Kg. |
|----------|------------|-----|
| 49750-00 | 25x16x21,5 | 2   |

**Dualit.****Waffle iron**

Macchina per cialde  
Waffeleisen  
Gufrier  
Gofrera

| art.     | cm.      | Kg. | kW  |
|----------|----------|-----|-----|
| 49809-00 | 40x22x19 | 5,5 | 1,6 |







**Single waffle iron, GESIMPLE**

Macchina per cialde  
Waffleisen mit 1 Platte  
Gaufrier simple  
Gofrera singular

| art.     | cm.        | Kg. | kW  |
|----------|------------|-----|-----|
| 49850-24 | 30,5x44x23 | 22  | 1,6 |

**Squares 20x25 mm.**



**Single waffle iron, GESIMPLE**

Macchina per cialde  
Waffleisen mit 1 Platte  
Gaufrier simple  
Gofrera singular

| art.     | cm.        | Kg. | kW  |
|----------|------------|-----|-----|
| 49850-25 | 30,5x44x23 | 22  | 1,6 |

**Squares 15x18 mm.**



**Single waffle iron, GESIMPLE**

Macchina per cialde  
Waffleisen mit 1 Platte  
Gaufrier simple  
Gofrera singular

| art.     | cm.        | Kg. | kW  |
|----------|------------|-----|-----|
| 49850-26 | 30,5x44x23 | 22  | 1,6 |



**Single waffle iron, GESIMPLE**

Macchina per cialde  
Waffleisen mit 1 Platte  
Gaufrier simple  
Gofrera singular

| art.     | cm.        | Kg. | kW  |
|----------|------------|-----|-----|
| 49850-27 | 30,5x44x23 | 22  | 1,6 |



**Single waffle iron, GES23**

Macchina per cialde  
Waffleisen mit 1 Platte  
Gaufrier simple  
Gofrera singular

| art.     | cm.        | Kg. | kW  |
|----------|------------|-----|-----|
| 49850-03 | 30,5x44x23 | 22  | 1,6 |



**SS**

**Infrared lamp with warming plate**

Lampada ad infrarossi con piano caldo  
Infrarot Wärmebrücke mit Wärmeplatte  
Lampe infrarouge avec plaque chauffante  
Lámpara infrarrojos y placa caliente

| art.     | GN  | cm.       | kW  |
|----------|-----|-----------|-----|
| 49993-21 | 1/1 | 38x53x70  | 0,5 |
| 49993-22 | 2/1 | 70x53x71  | 1,0 |
| 49993-23 | 3/1 | 103x53x70 | 1,5 |

**Curved plexiglass fender. Separate switches for plate and lamps. Adjustable thermostat +30°C +90°C.** – Parafiato in plexiglass curvo. Interruttori di accensione separati per piano caldo e lampade. Termostato regolabile +30°C +90°C.



**SS**

**Infrared lamp**

Lampada ad infrarossi  
Infrarot Wärmebrücke  
Lampe infrarouge  
Lámpara infrarrojos

| art.     | GN  | cm.       | kW   |
|----------|-----|-----------|------|
| 49993-01 | 1/1 | 38x53x70  | 0,25 |
| 49993-02 | 2/1 | 70x53x71  | 0,50 |
| 49993-03 | 3/1 | 103x53x70 | 0,75 |

**Curved plexiglass fender.** – Parafiato in plexiglass curvo.



SS

**Warming plate**

Piano caldo  
Wärmeplatte  
Plaque chauffante  
Placa caliente

| art.     | GN  | cm.      | kW   |
|----------|-----|----------|------|
| 49993-11 | 1/1 | 33x53x6  | 0,25 |
| 49993-12 | 2/1 | 66x53x6  | 0,50 |
| 49993-13 | 3/1 | 132x53x6 | 0,75 |

**Adjustable thermostat +30°C +90°C.** – Termostato regolabile +30°C +90°C.



SS

**Table with hot box**

Tavolino con box termico  
Tisch mit Hot Box  
Table avec hot box  
Carrito con hot box

| art.     | Ø cm.   | h. cm. | W   |
|----------|---------|--------|-----|
| 44094-02 | 90/54,6 | 77     | 500 |

**Table with fold down flaps.** – Tavolo con flaps pieghevoli.



SS

**Table with hot box**

Tavolino con box termico  
Tisch mit Hot Box  
Table avec hot box  
Carrito con hot box

| art.     | Ø cm.   | h. cm. | W   |
|----------|---------|--------|-----|
| 44094-04 | 90/54,6 | 78,6   | 500 |

**Table with fold down flaps. With capsizable top for stacking when not in use.**  
Tavolo con flaps pieghevoli. Ribaltabile e impilabile quando non in uso.



SS

**Table with hot box**

Tavolino con box termico  
Tisch mit Hot Box  
Table avec hot box  
Carrito con hot box

| art.     | Ø cm. | h. cm. | W   |
|----------|-------|--------|-----|
| 44094-06 | 90/73 | 76     | 500 |

**Table with fold down flaps. Foldable for saving space when not in use.** – Tavolo con flaps pieghevoli. Pieghevole per ridurre l'ingombro quando non in uso.

**Mixer/liquidiser combi unit**

Combi mixer/frusta  
Kombigerät  
Combiné mixeur-fouet  
Brazo triturador/batidor, unidad combinada

| art.     | h. cm. | Kg.  | kW   | rpm   |
|----------|--------|------|------|-------|
| 49907-01 | 79     | 4,95 | 0,35 | 15000 |

**For containers up to 100 liters.** – Per contenitori fino a 100 litri.

**Liquidiser**

Mixer  
Stabmixer  
Mixeur  
Brazo triturador

| art.     | h. cm. | Kg.  | kW   | rpm   |
|----------|--------|------|------|-------|
| 49907-06 | 55,5   | 1,45 | 0,25 | 15000 |

**For containers up to 30 liters.** – Per contenitori fino a 30 litri.





**Wall rack**

Supporto murale  
Wandständer  
Support mural  
Soporte mural

art.  
49907-AA



**Mini mixer**

Mini mixer  
Mini-Stabmixer  
Mini mixeur  
Mini batidora

| art.     | h. cm. | Kg.  | kW   | rpm         |
|----------|--------|------|------|-------------|
| 49808-00 | 40     | 0,78 | 0,45 | 12500-14000 |

SS  
ABS



**Liquidiser**

Mixer  
Stabmixer  
Mixeur  
Brazo triturador

| art.     | h. cm. | Kg. | kW   | rpm        |
|----------|--------|-----|------|------------|
| 49911-24 | 24     | 1,4 | 0,27 | 2000-12500 |
| 49916-25 | 25     | 3,0 | 0,27 | 2300-9600  |
| 49916-35 | 35     | 3,3 | 0,35 | 2300-9600  |
| 49916-45 | 45     | 4,9 | 0,44 | 1500-9000  |
| 49916-55 | 55     | 5,2 | 0,75 | 9000       |



**Mixer/liquidiser combi unit**

Combi mixer/frusta  
Kombigerät  
Combiné mixeur-fouet  
Brazo triturador/batidor, unidad combinada

| art.     | h. cm. | Kg. | kW   | rpm        |
|----------|--------|-----|------|------------|
| 49911-19 | 19     | 1,9 | 0,25 | 2000-12500 |
| 49911-30 | 30     | 3,1 | 0,30 | 2300-9600  |
| 49911-35 | 35     | 5,9 | 0,44 | 1500-9000  |
| 49911-45 | 45     | 6,1 | 0,50 | 1500-9000  |



**Juice extractor J80 Ultra**

Centrifuga  
Fruchtpresse  
Centrifugeur-presse agrumes  
Centrifugadora/exprimidor jugos

| art.     | cm.          | kg./H | Kg. | kW  | rpm  |
|----------|--------------|-------|-----|-----|------|
| 49949-20 | 23,5x42x50,5 | 60    | 11  | 0,7 | 3000 |



**Vegetable preparation machine CL 50 Ultra**

Tagliaverdure  
Gemüseschneidmaschine  
Coupe-légumes  
Cortador verduras

| art.     | cm.        | Kg. | kW   | rpm |
|----------|------------|-----|------|-----|
| 49940-01 | 30x36x55,5 | 15  | 0,55 | 375 |

**Suitable also for cutting mozzarella. For cutting discs contact our customer service. – Ideale anche per tagliare mozzarella. Per i dischi di taglio contatta il ns customer service.**



**Cutter & vegetable slicer R301 Ultra**

Combinato cutter/tagliaverdure  
Gemüseschneid/- u. Schälmaschine  
Cutter/Coupe-légumes  
Cortador verduras

| art.     | cm.        | lt. | Kg. | kW   | rpm  |
|----------|------------|-----|-----|------|------|
| 49942-01 | 28,5x36x40 | 3,7 | 14  | 0,65 | 1500 |

**For cutting discs contact our customer service.**  
Per i dischi di taglio contatta il ns customer service.

**Cutter & vegetable slicer R502 VV**

Combinato cutter/tagliaverdure  
Gemüseschneid/- u. Schälmaschine  
Cutter/Coupe-légumes  
Cortador verduras

| art.     | cm.          | lt. | Kg. | kW  | rpm      |
|----------|--------------|-----|-----|-----|----------|
| 49942-03 | 35,5x30x65,5 | 5,5 | 30  | 1,3 | 300>3500 |

**For cutting discs contact our customer service.**  
Per i dischi di taglio contatta il ns customer service.

**Table-top cutter R4**

Cutter da tavolo  
Gemüseschneidmaschine  
Cutter à légumes  
Cortador verduras

| art.     | cm.      | lt. | Kg. | kW  | rpm       |
|----------|----------|-----|-----|-----|-----------|
| 49943-01 | 21x32x43 | 4,5 | 17  | 0,9 | 1500/3000 |

**Table-top cutter R5 plus**

Cutter da tavolo  
Gemüseschneidmaschine  
Cutter à légumes  
Cortador verduras

| art.     | cm.      | lt. | Kg. | kW  | rpm       |
|----------|----------|-----|-----|-----|-----------|
| 49943-02 | 28x34x48 | 5,5 | 24  | 1,2 | 1500/3000 |

**Emulsifier-mixer Blixer 4**

Omogeneizzatore  
Mixergerät  
Emulsionneur-mixer  
Omogenizador/emulsificador

| art.     | cm.          | lt. | Kg. | kW | rpm       |
|----------|--------------|-----|-----|----|-----------|
| 49944-01 | 46x22,5x30,5 | 4,5 | 18  | 1  | 1500/3000 |

**Emulsifier-mixer Blixer 4 VV**

Omogeneizzatore  
Mixergerät  
Emulsionneur-mixer  
Omogenizador/emulsificador

| art.     | cm.          | lt. | Kg. | kW  | rpm      |
|----------|--------------|-----|-----|-----|----------|
| 49944-02 | 46x22,5x30,5 | 4,5 | 18  | 1,1 | 300>3500 |







**Sieving juicer C80**

Centrifuga  
Passiermaschine  
Centrifugeuse  
Centrifugadora

| art.     | cm.      | kg./H | Kg. | kW   | rpm  |
|----------|----------|-------|-----|------|------|
| 49946-01 | 61x36x54 | 50    | 21  | 0,65 | 1500 |



**Citrus fruit squeezer**

Spremiagrumi  
Zitruspresse  
Presse agrumes  
Exprimidor cítricos

| art.     | cm.      | Kg. | kW   | rpm  |
|----------|----------|-----|------|------|
| 49922-01 | 20x30x35 | 5   | 0,13 | 1500 |



**Citrus fruit squeezer**

Spremiagrumi  
Zitruspresse  
Presse agrumes  
Exprimidor cítricos

| art.     | cm.          | Kg. | kW   | rpm       |
|----------|--------------|-----|------|-----------|
| 49922-02 | 20,5x30,5x49 | 10  | 0,23 | 1500-1800 |



**Citrus fruit squeezer**

Spremiagrumi  
Zitruspresse  
Presse agrumes  
Exprimidor cítricos

| art.     | cm.      | Kg. | kW   | rpm       |
|----------|----------|-----|------|-----------|
| 49922-03 | 20x30x38 | 10  | 0,23 | 1500-1800 |



**Citrus fruit squeezer**

Spremiagrumi  
Zitruspresse  
Presse agrumes  
Exprimidor cítricos

| art.     | cm.      | Kg. | kW    | rpm       |
|----------|----------|-----|-------|-----------|
| 49922-04 | 24x40x49 | 10  | 0,275 | 1500-1800 |



**Juice extractor**

Centrifuga, spremisucchi  
Fruchtpresse  
Centrifugeur-presse agrumes  
Centrifugadora/exprimidor jugos

| art.     | cm.      | Kg. | kW  | rpm       |
|----------|----------|-----|-----|-----------|
| 49922-06 | 26x47x45 | 16  | 0,8 | 3000-3300 |



**Ice crusher**

Spaccagiaccio  
Eiszerstosser  
Broyeur à glace  
Triturador de hielo

| art.     | cm.      | Kg. | kW   | rpm   |
|----------|----------|-----|------|-------|
| 49922-08 | 24x35x47 | 10  | 0,13 | 73-89 |

**Drink Mixer**

Frullino frappè  
Getränkemixer  
Shaker électrique  
Batidora para batidos

| art.     | cm.        | Kg. | kW   | rpm        |
|----------|------------|-----|------|------------|
| 49949-09 | 18,6x18x53 | 6   | 0,12 | 8000-16000 |

**Equipped with 3 stirrers and 2 bowls, s/s and polycarbonate.**  
Fornito di 3 utensili agitatori e 2 bicchieri, inox e policarbonato.

**Blender**

Frullatore  
Getränkemixer  
Mixeur  
Licuadora

| art.     | cm.        | lt. | Kg. | kW  | rpm       |
|----------|------------|-----|-----|-----|-----------|
| 49922-22 | 30x22x56,6 | 2   | 11  | 1,2 | 500-15000 |
| 49922-23 | 30x22x56,6 | 4   | 11  | 1,2 | 500-15000 |

**Stainless steel bowl. – Bicchiere inox.**

**Blender**

Frullatore  
Getränkemixer  
Mixeur  
Licuadora

| art.     | cm.        | lt. | Kg. | kW  | rpm       |
|----------|------------|-----|-----|-----|-----------|
| 49922-20 | 30x22x56,6 | 2   | 11  | 1,2 | 500-15000 |
| 49922-21 | 30x22x56,6 | 4   | 11  | 1,2 | 500-15000 |

**Clear bowl BPA Free. – Bicchiere trasparente BPA Free.**

**Blender**

Frullatore  
Getränkemixer  
Mixeur  
Licuadora

| art.     | cm.      | Kg. | kW |
|----------|----------|-----|----|
| 49922-09 | 20x47x44 | 9   | 3  |

**Clear bowl BPA Free. – Bicchiere trasparente BPA Free.**

**Citrus fruit squeezer**

Spremiagrumi  
Zitruspresse mit Spritzschutz  
Presse agrumes  
Exprimidora

| art.     | cm.      | Kg. | kW  | rpm  |
|----------|----------|-----|-----|------|
| 49958-00 | 31x22x34 | 8   | 0,3 | 1400 |





**Lever citrus fruit squeezer**

Spremiagrumi a leva  
Zitruspresse mit Pressarm  
Presse agrumes à levier  
Exprimidora

| art.     | cm.      | Kg. | kW   | rpm  |
|----------|----------|-----|------|------|
| 49959-00 | 31x22x35 | 9   | 0,34 | 1400 |



**Blender**

Frullatore  
Getränkemixer  
Mixeur  
Licuadora

| art.     | cm.      | lt. | Kg. | kW  | rpm         |
|----------|----------|-----|-----|-----|-------------|
| 49956-01 | 20x20x46 | 1,7 | 4   | 0,4 | 10000-15000 |

**Plastic bowl.** – Bicchiera plastica.



**Blender**

Frullatore  
Getränkemixer  
Mixeur  
Licuadora

| art.     | cm.      | lt. | Kg. | kW | rpm         |
|----------|----------|-----|-----|----|-------------|
| 49957-00 | 23x23x52 | 3   | 5,5 | 1  | 12000-22000 |

**Stainless steel bowl.** – Bicchiera inox.



**Ice crusher**

Tritaghiaccio  
Eiszerstosser  
Broyeur à glace  
Trituradora de hielo

| art.     | cm.      | Kg. | kW   | rpm  |
|----------|----------|-----|------|------|
| 49960-00 | 42x21x29 | 11  | 0,34 | 1400 |



**Drink mixer**

Frullino  
Getränkemixer  
Shaker électrique  
Licuadora

| art.     | cm.      | lt. | Kg. | kW   | rpm   |
|----------|----------|-----|-----|------|-------|
| 49955-01 | 20x22x50 | 0,8 | 2,8 | 0,12 | 15000 |

**Plastic bowl.** – Bicchiera plastica.



**Rice steamer**

Cuoci riso a vapore  
Reiskocher  
Cuit riz  
Olla arroccera

| art.     | Ø cm. | h. cm. | lt. | kW |
|----------|-------|--------|-----|----|
| 49954-21 | 5,0   | 35     | 21  | 3  |





SS

**Steamer**

Vaporiera

Dampfer

Cuit vapeur

Olla para cocinar al vapor

| art.     | Ø cm. | h. cm. | lt. | Kg. | V   | kW |
|----------|-------|--------|-----|-----|-----|----|
| 49954-18 | 38    | 46     | 15  | 7   | 230 | 2  |

+70°C +80°C



SS

**Water boiler with tap**

Bollitore per acqua con rubinetto

Wasserkocher mit Hahn

Chauffe-eau avec robinet

Calentador de agua con grifo

| art.     | Ø cm. | h. cm. | lt. | Kg. | V   | kW  |
|----------|-------|--------|-----|-----|-----|-----|
| 49954-20 | 37    | 48     | 20  | 5,7 | 230 | 2,1 |

+30°C +100°C

**Planetary mixer**

Impastatrice planetaria

Knet- u. Schlagmaschine

Batteur-mélangeur

Batodira planetaria

| art.     | cm.      | lt. | Kg. | kW   | rpm  |
|----------|----------|-----|-----|------|------|
| 49947-08 | 30x40x58 | 7,6 | 27  | 0,18 | 1420 |

**3 speeds. Timer 0-15 min. – 3 velocità. Timer 0-15 min.****Planetary mixer**

Impastatrice planetaria

Knet- u. Schlagmaschine

Batteur-mélangeur

Batodira planetaria

| art.     | cm.        | lt. | Kg. | kW   | rpm    |
|----------|------------|-----|-----|------|--------|
| 49945-05 | 38x31x45,5 | 5   | 15  | 0,75 | 40>260 |

**10 speeds. – 10 velocità.**

SS

**Microwave oven - PROG**

Forno microonde

Mikrowelle

Four à micro-ondes

Microonda

| art.     | cm.            | lt. | Kg. | kW  |
|----------|----------------|-----|-----|-----|
| 49997-12 | 54,2x46,1x32,9 | 30  | 18  | 1,6 |

**5 power levels. Time key X2. Digital timer. 3 cooking stages, 5 power levels. 10 programmable keys. 20 programs.**

5 livelli di potenza, da 200 a 1000W. Tasto tempo X2. Timer digitale. 3 stadi cottura e 5 livelli di potenza. 10 tasti programmabili. 20 programmi.



SS

**Microwave oven - SELF**

Forno microonde

Mikrowelle

Four à micro-ondes

Microonda

| art.     | cm.            | lt. | Kg. | kW  |
|----------|----------------|-----|-----|-----|
| 49997-13 | 54,2x46,1x32,9 | 30  | 18  | 1,6 |

**Time key X2. Digital timer. "START" button preprogrammed "1 minute" at full power. Parameters customizable.**

Tasto tempo X2. Timer digitale. Tasto "START" pre-programmato "1 minuto" a piena potenza. Parametri pre-impostati personalizzabili.







**Sous-vide cooking device**

Apparecchio per cottura sottovuoto

Sous-Vide Garer

Cuiseur bain marie - sous vide

Equipo para cocinar al vacío

| art.     | cm.        | lt. | Kg. | kW   |
|----------|------------|-----|-----|------|
| 49954-22 | 36x29,2x29 | 11  | 5,9 | 0,85 |

**Cooks food in vacuum-sealed pouches submerged in a water bath held at a precisely-controlled temperature from 30°C to 100°C.**

Per cuocere a bagnomaria in buste sottovuoto. La temperatura è mantenuta precisamente costante e può essere regolata da 30°C a 100°C.



SS

**Sous-vide water bath**

Apparecchio per cottura sottovuoto

Sous-Vide Garer

Cuiseur bain marie - sous vide

Equipo para cocinar al vacío

| art.     | cm.      | lt. | Kg. | kW  |
|----------|----------|-----|-----|-----|
| 49952-08 | 22x25x38 | 8   | 4   | 0,8 |

**LED touch screen controls. The temperature can be set between 30 and 90°C and time between 0 and 99 hours. Stainless steel lid and wire rack included.**

Controlli touchscreen a LED. La temperatura può essere impostata tra 30 e 90°C, tempo tra 0 e 99 ore. Coperchio e griglia in acciaio inossidabile inclusi.



**Soft cooker**

Apparecchio per cottura sottovuoto

Sous-Vide-Garer

Thermoplongeur

Máquina para cocinar al vacío

| art.     | cm.          | Kg. | kW  |
|----------|--------------|-----|-----|
| 49851-10 | 16,4x22x41,5 | 8   | 0,2 |

**Stainless steel structure. Suitable for containers up to 60 liters. Min. height of the tank 180 mm, electronic temperature control with 1/10°C precision, adjustable temperature 0>95°C. Pump for water circulation. Acoustic timer. Possibility to memorize up to 20 programs. Level sensor for lack of water.**

Struttura in acciaio inox. Per recipienti fino a 60 litri. Altezza minima del recipiente 180 mm, controllo elettronico della temperatura con precisione al 1/10°C, temperatura regolabile 0>95°C. Pompa per la circolazione dell'acqua. Timer acustico. Possibilità di memorizzare fino a 20 programmi. Sensore di livello per mancanza acqua.



**Induction cooker TC 3500**

Piastra ad induzione  
Induktionsplatte  
Plaque à induction  
Placa de inducción

| art.     | cm.        | Kg. | kW  |
|----------|------------|-----|-----|
| 49998-35 | 35,5x46x11 | 5,5 | 3,5 |

**Stainless steel body, Schott Ceran surface. Thermocontrol. 12 power levels. Temperature preselection 60-240°C. Timer 23 hours 59 min.**  
Corpo in acciaio inox, piano Schott Ceran. Thermocontrol. 12 livelli di potenza. Preselezione temperatura 60-240°C. Timer 23 ore 59'.

**Induction cooker**

Piastra ad induzione  
Induktionsplatte  
Plaque à induction  
Placa de inducción

| art.     | cm.      | Kg. | kW  |
|----------|----------|-----|-----|
| 18162-RA | 30x37x10 | 6   | 2,7 |

**Stainless steel body, Schott ceran surface. Timer 0-180 min. 10 power levels. Temperature range 60-240°C.** – Corpo inox, piano Schott ceran. Timer 0-180 min. 10 livelli di potenza. Temperatura 60-240°C.

**Induction cooker, to be built into counter**

Piastra ad induzione da incasso  
Induktionsplatte, thekeneinbau  
Plaque à induction encastrable  
Placa de inducción para emportar

| art.     | cm.        | Kg. | kW  |
|----------|------------|-----|-----|
| 18162-RB | 36X38x12,5 | 5,7 | 3,5 |

**Schott ceran surface. Timer 0-180 min. 10 power levels. Temperature range 60-240°C.** – Piano Schott ceran. Timer 0-180 min. 10 livelli di potenza. Temperatura 60-240°C.

**Induction cooker, to be built into counter**

Piastra ad induzione da incasso  
Induktionsplatte, thekeneinbau  
Plaque à induction encastrable  
Placa de inducción para emportar

| art.     | cm.         | Kg. | kW |
|----------|-------------|-----|----|
| 49998-20 | 35,5x35,5x6 | 3,4 | 2  |

**Schott ceran surface. 5 power levels. Temperature range 60-240°C.**  
Piano Schott ceran. 5 livelli di potenza. Temperatura 60-240°C.

**Induction station**

Stazione induzione  
Induktionsstation  
Station d'induction  
Estación inducción

| art.     | Ø cm. | cm.          | V       | W   |
|----------|-------|--------------|---------|-----|
| 49999-04 | 24    | 35,4x32,5x19 | 220-240 | 900 |

**Induction plate with temperature regulator 60>140°C. Black metal support, walnut wood insert and stainless steel frame.**

Piastra a induzione con regolatore di temperatura 60>140°C. Supporto in metallo nero, inserto in legno di noce e cornice inox.

NEW

**Coffee percolator**

Percolatore per caffè  
Kaffee-Perkolator  
Percolateur à café  
Percolator de café

| art.     | Ø cm. | h. cm. | lt.  | W    |
|----------|-------|--------|------|------|
| 49846-05 | 28    | 38,5   | 4,5  | 950  |
| 49846-09 | 28    | 38,5   | 9,2  | 950  |
| 49846-15 | 33    | 54,0   | 15,0 | 1650 |

SS





SS

**Samovar PYRAMID**

Samovar  
Samovar  
Samovar  
Samovar

| art.     | cm.          | lt.   | W    |
|----------|--------------|-------|------|
| 49856-04 | 35,5x30x45,2 | 4+1,2 | 2500 |

**Teapot with strainer. Cable length approx. 130 cm. With 2 heating elements 2000W and 500W.** – Teiera con colino. Lunghezza cavo circa 130 cm. Con 2 resistenze 2000W e 500W.



SS

**Samovar 2017**

Samovar  
Samovar  
Samovar  
Samovar

| art.     | cm.          | lt.   | W    |
|----------|--------------|-------|------|
| 49854-03 | 31x27,5x48,5 | 3+1,2 | 1500 |

**Teapot with strainer, cable length approx. 130 cm.**  
Teiera con colino. Lunghezza cavo circa 130 cm.



SS

**Samovar ROMANOV**

Samovar  
Samovar  
Samovar  
Samovar

| art.     | cm.      | lt.   | W    |
|----------|----------|-------|------|
| 49855-05 | 34x27x59 | 5+1,3 | 1800 |

**Teapot with strainer. Cable length approx. 100 cm. With 2 heating elements 1300W and 500W.** – Teiera con colino. Lunghezza cavo circa 100 cm. Con 2 resistenze 1300W e 500W.



SS

**Samovar 3006C**

Samovar  
Samovar  
Samovar  
Samovar

| art.     | cm.          | lt.   | W    |
|----------|--------------|-------|------|
| 49854-06 | 35,5x30x45,2 | 6+1,5 | 2500 |

**Teapot with strainer. With 2 heating elements 2000W and 500W.**  
Teiera con colino. Con 2 resistenze 2000W e 500W.



SS

**Samovar SORAYA**

Samovar  
Samovar  
Samovar  
Samovar

| art.     | cm.          | lt.    | W    |
|----------|--------------|--------|------|
| 49855-10 | 35,2x44,5x69 | 10+1,6 | 3000 |

**Teapot with strainer. Cable length approx. 130 cm. With 2 heating elements 2300W and 700W.** – Teiera con colino. Lunghezza cavo circa 130 cm. Con 2 resistenze 2300W e 700W.



SS

**Samovar KATHARINA**

Samovar  
Samovar  
Samovar  
Samovar

| art.     | cm.            | lt.  | W    |
|----------|----------------|------|------|
| 49855-15 | 39,5x44,5x74,5 | 15+2 | 3000 |

**Teapot with strainer. Cable length approx. 130 cm. With 2 heating elements 2300W and 700W.** – Teiera con colino. Lunghezza cavo circa 130 cm. Con 2 resistenze 2300W e 700W.





SS

**Chocolate fountain**

Fontana cioccolato  
Schokoladenbrunnen  
Fontaine à chocolat  
Fuente para chocolate

| art.     | Ø cm. | h. cm. | lt. | W   |
|----------|-------|--------|-----|-----|
| 42982-08 | 38    | 80     | 3,5 | 370 |

**230V-50Hz-Amps 1,6A. Minimum quantity of chocolate necessary for operation is about 3.5 kg, the maximum is 8 kg.** – Quantità minima di cioccolata richiesta per funzionare è di circa 3,5 kg e può contenerne fino a 8 kg.



PP

SS

**Soup kettle**

Zuppiera  
Suppenwärmer  
Marmite à soupe  
Marmita para sopa

| art.     | Ø cm. | h. cm. | lt. | W       |
|----------|-------|--------|-----|---------|
| 49847-38 | 38    | 36,5   | 10  | 450-550 |

**Soup kettle**

Zuppiera  
Suppenwärmer  
Marmite à soupe  
Marmita para sopa

| art.     | Ø cm. | h. cm. | lt. | W   |
|----------|-------|--------|-----|-----|
| 49847-08 | 33    | 37     | 10  | 400 |

**Raclette maker**

Macchina per raclette  
Raclette Tischgerät  
Appareil à raclette  
Máquina raclette

| art.     | cm.          | V   | W   |
|----------|--------------|-----|-----|
| 42420-06 | 44,5x21,5x30 | 230 | 850 |

**Foldable model with transport hook. 2 heating ramps, adjustable height. Suitable for cheese size 1/6 to 1/3 of a wheel. In stainless steel and painted steel.** – Modello pieghevole con gancio di trasporto. 2 rampe di riscaldamento, altezza regolabile. Adatto per formaggi da 1/6 a 1/3 di una forma. In acciaio inossidabile e acciaio verniciato.

**Raclette maker**

Macchina per raclette  
Raclette Tischgerät  
Appareil à raclette  
Máquina raclette

| art.     | cm.        | V   | W   |
|----------|------------|-----|-----|
| 42420-08 | 46x26,5x40 | 230 | 850 |

**Tiltable and easily removable cheese holder. Heating block adjustable height. Ideal for 6-8 people, 1/2 shape. Cheese holder in stainless steel and epoxy painted steel structure.** – Porta formaggio inclinabile e facilmente rimovibile. Blocco riscaldante regolabile in altezza. Ideale per 6-8 persone, 1/2 forma. Porta formaggio in acciaio inossidabile e struttura in acciaio verniciato epossidico.

**Raclette maker, 4 pans**

Macchina per raclette, 4 padelle  
Raclette Tischgerät, 4 Pfannen  
Appareil à raclette, 4 poêlons  
Máquina raclette

| art.     | cm.      | W   |
|----------|----------|-----|
| 41318-00 | 51x10x12 | 600 |

**Non-stick upper plate for all cooking (vegetables, meats, etc.).**  
Piastra superiore antiaderente per tutte le cotture (verdure, carne, ecc.).







**Sugar lamp**

Lampada per zucchero  
Zuckerlampe  
Lampe à sucre  
Lâmpara para açúcar

| art.     | cm.      | Kg. |
|----------|----------|-----|
| 47840-11 | 61x41x50 | 6,4 |

**Stainless steel. Infrared lamp, 3 selection powers 500-1000-1500W. Cable included.** – Acciaio inox. Lampada infrarossi con 3 potenze selezionabili, 500-1000-1500W. Incl. cavo di alimentazione.



**Spray gun**

Pistola  
Sprühpistole  
Pistolet  
Pistola

| art.     | ml. | Kg. | W  | rpm |
|----------|-----|-----|----|-----|
| 47848-07 | 700 | 1,1 | 60 | 280 |

**Usable for hot liquids max. 65 °C. Equipped with nozzle 0,6 mm.**  
Per liquidi caldi max. 65°C. Bocchetta in dotazione da 0,6 mm.



**ABS**

**Tempering unit**

Temperatrice  
Temperiergerät  
Tempéreuse  
Templadora

| art.     | Ø cm. | h. cm. | lt. |
|----------|-------|--------|-----|
| 47698-01 | 20,5  | 21,2   | 1,7 |

**For ice cream parlours, ideal for chocolate coatings of ice creams on sticks. Can be used straight on the counter. Removable anodized aluminum tank.**  
Per gelaterie, ideale per coperture in cioccolato di gelati e semifreddi su stecco. Può essere utilizzato direttamente sul banco. Vasca estraibile in alluminio anodizzato.



**ABS**

**Tempering unit**

Temperatrice  
Temperiergerät  
Tempéreuse  
Templadora

| art.     | Ø cm. | h. cm. | lt. |
|----------|-------|--------|-----|
| 47698-02 | 26    | 16     | 1,8 |

**Mini dry melter, allows to process tiny chocolate quantities without any waste. Practical removable tank.** – Mini scioglitore a secco, adatto per piccole produzioni senza sprechi. Pratica vasca estraibile.



**SS**

**ABS**

**Tempering unit**

Temperatrice  
Temperiergerät  
Tempéreuse  
Templadora

| art.     | cm.        | lt. |
|----------|------------|-----|
| 47698-03 | 40x24x13,5 | 3,6 |
| 47698-06 | 40x33x13,5 | 6,0 |

**Analog tempering units. Housing made with heat-resistant plastic. Removable stainless steel tank. UK/US/JAPAN/AUSTRALIA/CHINA wirings upon request.**  
Temperatrici analogiche. In materiale plastico termoresistente. Vasca inox removibile. Su richiesta cablaggio GB/USA/GIAPPONE/AUSTRALIA/CINA.



**SS**

**ABS**

**Tempering unit, digital**

Temperatrice digitale  
Temperiergerät, digital  
Tempéreuse digitale  
Templadora digital

| art.     | cm.        | lt. |
|----------|------------|-----|
| 47698-07 | 40x33x13,5 | 6,0 |

**Made of heat-resistant plastic material, stainless steel tank and lid, thermal probe for chocolate temperature control. Tempering manually adjustable or following the 3 programs depending on the type of chocolate: white, milk and dark.** – In materiale plastico termoresistente, vasca e coperchio in acciaio inox, sonda termica per la regolazione della temperatura del cioccolato. Temperaggio regolabile manualmente o seguendo i 3 programmi in base al tipo di cioccolato: bianco, al latte e fondente.

**Airbrush compressor**

Compressore per penna aerografa  
Airbrush Kompressor  
Compresseur  
Compresor

| art.     | cm.      | W   |
|----------|----------|-----|
| 47844-06 | 16x30x23 | 200 |

**Cap. 4 bar.**

**Caramelizer**

Caramellizzatore  
Caramelaiser-Eisen  
Carameliseur  
Quemador

| art.     | Ø cm. | W    |
|----------|-------|------|
| 47847-10 | 10    | 0,65 |
| 47847-12 | 12    | 1,00 |

**Caramelizer**

Caramellizzatore  
Caramelaiser-Eisen  
Carameliseur  
Quemador

| art.     | l. cm. | W   |
|----------|--------|-----|
| 47847-23 | 23     | 1,5 |

**Meat mincer**

Tritacarne  
Fleischwolf  
Hachoir  
Picadora de carne

| art.     | cm.      | Kg. | kW   |
|----------|----------|-----|------|
| 49921-00 | 18x42x43 | 6   | 0,35 |

**Gravity slicing machine**

Affettatrice a gravità  
Schräg Aufschnittmaschine  
Trancheuse à gravité  
Cortadora de gravedad

| art.      | Ø cm. | cm.        | Kg. | rpm |
|-----------|-------|------------|-----|-----|
| 49975-19  | 19,5  | 52x36x31,5 | 10  | 300 |
| 49975U19* | 19,5  | 52x36x31,5 | 10  | 300 |

\*Extra CE. Built-in blade sharpener. – Extra CE. Affilatoio fisso.

**Gravity slicing machine**

Affettatrice a gravità  
Schräg Aufschnittmaschine  
Trancheuse à gravité  
Cortadora de gravedad

| art.      | Ø cm. | cm.        | Kg.  | rpm |
|-----------|-------|------------|------|-----|
| 49975-25  | 25    | 62x42,5x37 | 15,5 | 300 |
| 49975U25* | 25    | 62x42,5x37 | 15,5 | 300 |

\*Extra CE. Built-in blade sharpener. – Extra CE. Affilatoio fisso.





**Gravity slicing machine**

Affettatrice a gravità  
Schräg Aufschnittmaschine  
Trancheuse à gravité  
Cortadora de gravedad

| art.      | Ø cm. | cm.        | Kg. | rpm |
|-----------|-------|------------|-----|-----|
| 49975-22  | 22    | 58x40,5x34 | 10  | 300 |
| 49975U22* | 22    | 58x40,5x34 | 10  | 300 |

**\*Extra CE. Buit-in blade sharpener. – Extra CE. Affilatoio fisso.**



**Gravity slicing machine**

Affettatrice a gravità  
Schräg Aufschnittmaschine  
Trancheuse à gravité  
Cortadora de gravedad

| art.      | Ø cm. | cm.        | Kg. | rpm |
|-----------|-------|------------|-----|-----|
| 49975-30  | 30    | 65x49,5x44 | 23  | 300 |
| 49975U30* | 30    | 65x49,5x44 | 23  | 300 |

**\*Extra CE. Buit-in blade sharpener. – Extra CE. Affilatoio fisso.**



**Gravity slicing machine**

Affettatrice a gravità  
Schräg Aufschnittmaschine  
Trancheuse à gravité  
Cortadora de gravedad

| art.      | Ø cm. | cm.        | Kg. | rpm |
|-----------|-------|------------|-----|-----|
| 49975-35  | 35    | 89x58,5x48 | 36  | 260 |
| 49975U35* | 35    | 89x58,5x48 | 36  | 260 |

**\*Extra CE. Buit-in blade sharpener. – Extra CE. Affilatoio fisso.**



**Vertical slicing machine**

Affettatrice verticale  
Vertikal Aufschnittmaschine  
Trancheuse verticale  
Cortadora vertical

| art.      | Ø cm. | cm.      | Kg. | rpm |
|-----------|-------|----------|-----|-----|
| 49974-25  | 25    | 53x52x50 | 24  | 300 |
| 49974U25* | 25    | 53x52x50 | 24  | 300 |

**\*Extra CE. – Extra CE.**



**Vertical slicing machine**

Affettatrice verticale  
Vertikal Aufschnittmaschine  
Trancheuse verticale  
Cortadora vertical

| art.      | Ø cm. | cm.      | Kg. | rpm |
|-----------|-------|----------|-----|-----|
| 49974-30  | 30    | 53x52x50 | 27  | 300 |
| 49974U30* | 30    | 53x52x50 | 27  | 300 |

**\*Extra CE. – Extra CE.**





SS

**Sieve**

Passaverdura  
Passiergerät  
Moulin  
Molino

| art.     | Ø cm. | h. cm. | kg./H | Kg.  | W   |
|----------|-------|--------|-------|------|-----|
| 49879-37 | 37    | 108    | 300   | 23,5 | 600 |

**Threephase motor 380V. Disc 3 mm. – Motore trifase 380V. Griglia 3 mm.**



SS

**Can opener**

Apriscatole  
Dosenöffner  
Ouvre-boîte  
Abrelatas

| art.     | cm.      | Kg. |
|----------|----------|-----|
| 49814-00 | 44x25x75 | 13  |

**Dual speed motor. Opens all can shapes from 50 to 270 mm height.  
Motore a 2 velocità. Per formati scatola da 50 a 270 mm di altezza.**



SS

**Knife sterilizer**

Sterilizzatore per coltelli  
Messerentkeimer  
Armoire de sterilisation  
Esterilizador para cuchillos

| art.     | cm.        | W  |
|----------|------------|----|
| 49871-10 | 57,5x17x60 | 15 |

**Plexiglas door, magnetic lock. Timer setting from 0 up to 2 hours. Door with stop device when opening. Protection IP 24.**



SS

**Knife sterilizer**

Sterilizzatore per coltelli  
Messerentkeimer  
Armoire de sterilisation  
Esterilizador para cuchillos

| art.     | cm.       | W  |
|----------|-----------|----|
| 49871-20 | 103x17x60 | 30 |

**Porta in plexiglas, chiusura magnetica. Programmabile da 0 a 2 ore. Dispositivo d'arresto all'apertura porta. Indice di protezione IP 24.**



Edlund

**Knife sharpener**

Affilacoltelli  
Messerschleifapparat  
Aiguiseur  
Afilador

| art.     | cm.      | Kg. | W   | rpm  |
|----------|----------|-----|-----|------|
| 49872-00 | 25x10x12 | 4   | 172 | 1550 |

**ABS knife guide. Pressure sensitive motor shuts down automatically.  
Guida in ABS estraibile. Motore con dispositivo autobloccante.**

**Knife sharpener**

Affilacoltelli  
Messerschleifapparat  
Aiguiseur  
Afilador

| art.     | cm.      | Kg. |
|----------|----------|-----|
| 49741-15 | 23x33x16 | 6,4 |
| 49741-07 | 23x16x16 | 4,6 |





GLUTEN-FREE COOKING  
CUCINA SENZA GLUTINE

# CUCINA SENZA GLUTINE

FOR GLUTEN-FREE COOKING



**UNA LINEA COMPLETA DI ARTICOLI E STRUMENTI PROFESSIONALI FACILMENTE IDENTIFICABILI PER:**

- diminuire il rischio di accidentali contaminazioni crociate degli alimenti;
- facilitare il professionista nell'operare e nell'offrire un servizio a favore del cliente con intolleranza al glutine;
- sensibilizzare il settore sul tema "gluten free" di fronte alle nuove esigenze dei consumatori.

**A FULL LINE OF HORECA TOOLS AND ITEMS, EASY TO IDENTIFY, AIMED AT:**

- reducing the risk of accidental food cross-contamination;
- making it easier for professionals to work and to provide services to clients with gluten intolerance;
- raising awareness on the gluten-free diet issue in the industry so as to respond to the new needs of consumers.



### Frypan

Padella

| art.     | Ø cm. |
|----------|-------|
| 11014F20 | 20    |
| 11014F24 | 24    |
| 11014F28 | 28    |
| 11014F32 | 32    |



### Cover

Coperchio

| art.     | Ø cm. |
|----------|-------|
| 11161F16 | 16    |
| 11161F20 | 20    |
| 11161F24 | 24    |
| 11161F28 | 28    |



### Baking sheet alusteel

Teglia forno, acciaio alluminato

| art.     | Ø cm. |
|----------|-------|
| 11739F20 | 20    |
| 11739F24 | 24    |
| 11739F28 | 28    |
| 11739F32 | 32    |



### Strainer with hook

Colapasta con manico e gancio

| art.     | Ø cm. |
|----------|-------|
| 11924F20 | 20    |



### Conical colander

Colapasta tronco conico

| art.     | Ø cm. |
|----------|-------|
| 11930F24 | 24    |





**One piece ladle**  
Mestolo unipezzo



| art.     | Ø cm. |
|----------|-------|
| 11970F06 | 6,5   |
| 11970F08 | 8,0   |
| 11970F10 | 10    |



**One piece skimmer**  
Schiumarola unipezzo



| art.     | Ø cm. |
|----------|-------|
| 11971F10 | 10    |
| 11971F12 | 12    |



**One piece perforated spatula**  
Paletta forata unipezzo



| art.     | Ø cm. |
|----------|-------|
| 11973F10 | 10    |
| 11973F12 | 12    |



**One piece basting spoon**  
Cucchiaione unipezzo



| art.     |
|----------|
| 11982F38 |



**Stock pot**  
Pentola alta



| art.     | Ø cm. |
|----------|-------|
| 12001F20 | 20    |
| 12001F24 | 24    |
| 12001F28 | 28    |



**Saucepot 2 handles**  
Casseruola alta 2 maniglie



| art.     | Ø cm. |
|----------|-------|
| 12007F16 | 16    |
| 12007F24 | 24    |
| 12007F28 | 28    |



**Colander for low stock pot**  
Colapasta per pentola bassa



| art.     | Ø cm. |
|----------|-------|
| 12123F20 | 20    |
| 12123F24 | 24    |
| 12123F28 | 28    |



**Wire whip, 8 wires**  
Frusta 8 fili



| art.     | l. cm. |
|----------|--------|
| 12928F30 | 30     |
| 12928F35 | 35     |



**Egg whisk, 11 wires**  
Frusta 11 fili



| art.     | l. cm. |
|----------|--------|
| 12929F30 | 30     |
| 12929F35 | 35     |



**Gastronorm Container**  
Bacinella gastronorm



| art.     | GN  | dim. cm.    |
|----------|-----|-------------|
| 14102F02 | 1/1 | 53x32,5x2   |
| 14102F04 | 1/1 | 53x32,5x4   |
| 14102F06 | 1/1 | 53x32,5x6,5 |
| 14102F10 | 1/1 | 53x32,5x10  |
| 14102F15 | 1/1 | 53x32,5x15  |
| 14102F20 | 1/1 | 53x32,5x20  |
| 14103F02 | 2/3 | 35,3x32x2   |
| 14103F04 | 2/3 | 35,3x32x4   |
| 14103F06 | 2/3 | 35,3x32x6,5 |
| 14103F10 | 2/3 | 35,3x32x10  |
| 14103F15 | 2/3 | 35,3x32x15  |
| 14103F20 | 2/3 | 35,3x32x20  |
| 14104F06 | 2/4 | 53x16,2x6,5 |
| 14104F10 | 2/4 | 53x16,2x10  |
| 14104F15 | 2/4 | 53x16,2x15  |
| 14105F02 | 1/2 | 32x26,5x2   |
| 14105F04 | 1/2 | 32x26,5x4   |
| 14105F06 | 1/2 | 32x26,5x6,5 |
| 14105F10 | 1/2 | 32x26,5x10  |
| 14105F15 | 1/2 | 32x26,5x15  |
| 14105F20 | 1/2 | 32x26,5x20  |
| 14107F06 | 1/3 | 32,5x18x6,5 |
| 14107F10 | 1/3 | 32,5x18x10  |
| 14107F15 | 1/3 | 32,5x18x15  |
| 14107F20 | 1/3 | 32,5x18x20  |
| 14108F06 | 1/4 | 26,5x16x6,5 |
| 14108F10 | 1/4 | 26,5x16x10  |
| 14108F15 | 1/4 | 26,5x16x15  |
| 14108F20 | 1/4 | 26,5x16x20  |
| 14109F06 | 1/6 | 17,6x16x6,5 |
| 14109F10 | 1/6 | 17,6x16x10  |
| 14109F15 | 1/6 | 17,6x16x15  |
| 14109F20 | 1/6 | 17,6x16x20  |
| 14110F06 | 1/9 | 17,6x11x6,5 |
| 14110F10 | 1/9 | 17,6x11x10  |



**Gastronorm cover**  
Coperchio gastronorm



| art.     | GN  |
|----------|-----|
| 14502F00 | 1/1 |
| 14503F00 | 2/3 |
| 14504F00 | 2/4 |
| 14505F00 | 1/2 |
| 14507F00 | 1/3 |
| 14508F00 | 1/4 |
| 14509F00 | 1/6 |
| 14510F00 | 1/9 |

**GN-lids****GN coperchi**

| art.     | GN  | dim. cm.  |
|----------|-----|-----------|
| 14922-77 | 1/1 | 53x3,25   |
| 14925-77 | 1/2 | 32,5x26,5 |
| 14927-77 | 1/3 | 32,5x17,5 |
| 14928-77 | 1/4 | 26,4x16,2 |
| 14929-77 | 1/6 | 17,6x16,2 |
| 14930-77 | 1/9 | 17,6x10,8 |

**GN-containers****GN bacinelle**

| art.     | GN  | dim. cm.     | lt.  |
|----------|-----|--------------|------|
| 15101-10 | 1/1 | 53x32,5x10   | 13,3 |
| 15105-10 | 1/2 | 32,5x26,5x10 | 6,1  |
| 15107-10 | 1/3 | 32,5x17,5x10 | 3,8  |
| 15108-10 | 1/4 | 26,4x16,2x10 | 2,6  |
| 15109-10 | 1/6 | 17,6x16,2x10 | 1,6  |
| 15110-10 | 1/9 | 17,6x10,8x10 | 0,9  |

**Bread knife****Coltello pane**

| art.     | l. cm. |
|----------|--------|
| 18028F21 | 21     |
| 18028F25 | 25     |
| 18028F30 | 30     |
| 18028F36 | 36     |

**Pizza wheel****Rotella tagliapizza**

| art.     | Ø cm. |
|----------|-------|
| 18324F10 | 10    |

**Spatula perforated****Spatola pasticcio e pizza forata**

| art.     |
|----------|
| 18510F07 |

**Pizza turner****Spatola per pasticcio e pizza**

| art.     |
|----------|
| 18511F15 |

**Pastry spatula****Spatola per dolci**

| art.     |
|----------|
| 18513F14 |

**Perforated pizza peel, aluminum****Pala pizza forata, alluminio**

| art.     | Ø cm. | dim. cm. | l. cm. |
|----------|-------|----------|--------|
| 41704G33 | -     | 33x33    | 150    |
| 41704G36 | -     | 36x36    | 150    |







**Perforated pizza peel, small**  
Palettino pizza forato

| art.     | Ø cm. | dim. cm. | l. cm. |
|----------|-------|----------|--------|
| 41737G20 | 20    | -        | 150    |
| 41737G23 | 23    | -        | 150    |



**Adjustable brush**  
Spazzola orientabile

| art.     | Ø cm. | dim. cm. | l. cm. |
|----------|-------|----------|--------|
| 41767G20 | -     | 20x6     | 160    |



**Baking sheet alusteel**  
Teglia rettangolare, alluminata

| art.     | dim. cm. |
|----------|----------|
| 41751F30 | 30x23x3  |
| 41751F40 | 40x30x3  |
| 41751F60 | 60x40x3  |



**Cutting board**  
Tagliere

| art.     | GN  | dim. cm.  | col. |
|----------|-----|-----------|------|
| 42522-07 | -   | 32x26,5x2 | ●    |
| 42538-07 | 1/1 | 53x32,5x2 | ●    |
| 42539-07 | -   | 60x40x2   | ●    |



**Cutting board**  
Tagliere

| art.     | GN  | dim. cm.  | col. |
|----------|-----|-----------|------|
| 42522F09 | 1/2 | 32x26,5x2 | ●    |
| 42538F09 | 1/1 | 53x32,5x2 | ●    |
| 42539F09 | -   | 60x40x2   | ●    |



**Labels 14 allergens**  
Etichette 14 allergeni

| art.     | dim. cm. | Pcs/Pz |
|----------|----------|--------|
| 44630-02 | 7,5x4    | 500    |

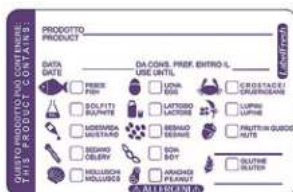

**Labels Allergens**  
Etichette allergeni

| art.     | dim. cm. | Pcs/Pz |
|----------|----------|--------|
| 44630-06 | 7x4,5    | 500    |



**Delivery labels with allergens**  
Etichette delivery con allergeni



| art.     | dim. cm. | Pcs/Pz |
|----------|----------|--------|
| 44630-07 | 14x4,5   | 250    |



**Milk frothing thermometers, 3 pcs**  
Termometri latte/barista, 3 pz



| art.     | Ø cm. |           |     |
|----------|-------|-----------|-----|
| 49709-03 | 4,5   | -10+110°C | 1°C |



**Digital thermometer**  
Termometro digitale



| art.     |               |         |
|----------|---------------|---------|
| 49880-17 | -49,9>299,9°C | 0,1/1°C |



**Bread tongs**  
Molla pane



| art.     | l. cm. |
|----------|--------|
| 52550F63 | 23     |



**Spaghetti tongs**  
Molla spaghetti



| art.     | l. cm. |
|----------|--------|
| 52550F73 | 21     |



**Toast-pastry tongs**  
Molla toast-dolci



| art.     | l. cm. |
|----------|--------|
| 52550F78 | 24     |



**Cake pliers**  
Pinza torta



| art.     | l. cm. |
|----------|--------|
| 52550F80 | 28     |



**Pastry pliers**  
Pinza dolci



| art.     | l. cm. |
|----------|--------|
| 52550F88 | 18     |

**SPARE PARTS**  
**RICAMBI**



**Tap/Rubinetto : For/Per # 11102**

art.  
11102-99



**Roasting pan grid/Griglia brasiera : For/Per # 11965**

| art.     | dim. cm. |
|----------|----------|
| 11966-50 | 50x30    |
| 11966-60 | 60x35    |
| 11966-61 | 61x43    |



**Clutch left, Asia rectangular/Frizione sx Asia rettangolare**

art.  
18132-KP



**Clutch right, Asia rectangular/Frizione dx Asia rettangolare**

art.  
18132-KQ



**Clutch right Asia /Frizione dx Asia**

| art.     | Ø cm. |
|----------|-------|
| 18136-KQ | 33-40 |



**Clutch left, Asia/Frizione sx Asia**

| art.     | Ø cm. |
|----------|-------|
| 18136-KP | 33    |
| 18136-KR | 40    |



**Clutch spring for rect. ABS, long side opening/Frizione molla ABS rett., apertura lato lungo**

art.  
18162-AF



**Clutch spring for rect. ABS, short side opening/Frizione molla ABS rett., apertura lato corto**

art.  
18162-AG



#### Spare parts/Ricambi : For/Per # 18166A

| art.     | des             | Ø cm. |
|----------|-----------------|-------|
| 18166-AD | Clutch/Frizione | 24    |
| 18166-AE | Clutch/Frizione | 36    |
| 18166-AF | Clutch/Frizione | 40    |
| 18166-AH | Clutch/Frizione | 30    |



#### Spare parts/Ricambi : For/Per # 18172A54

| art.     | des                          |
|----------|------------------------------|
| 18172-AF | Clutch spring/Frizione molla |



#### Spare parts/Ricambi : For/Per # 18172A56

| art.     | des                          |
|----------|------------------------------|
| 18172-AG | Clutch spring/Frizione molla |



#### Spare parts/Ricambi : For/Per # 18176A

| art.     | des   |
|----------|---|
| 18176-AE | Clutch for ABS Ø cm 36/Frizione ABS Ø cm 36 |
| 18176-AF | Clutch for ABS Ø cm 40/Frizione ABS Ø cm 40 |
| 18176-AH | Clutch for ABS Ø cm 30/Frizione ABS Ø cm 30 |



#### Cutlery bag Borsa porta coltelli

| art.     |
|----------|
| 18190-AA |



#### Spare parts/Ricambi : For/Per # 18353-17

| art.     | des                                 |
|----------|-------------------------------------|
| 18353-AA | Juice container/Contentitore succhi |
| 18353-BB | Tap/Rubinetto                       |
| 18353-CA | Lid/Coperchio                       |
| 18353-DB | Drip bowl/Ciotola raccogli gocce    |
| 18353-VA | Eutectic pad/Contentitore eutettico |



#### Spare parts/Ricambi : For/Per # 19810-00

| art.     | des                |
|----------|--------------------|
| 19810-AA | Blade/Lama         |
| 19810-AB | Gear/Ruota dentata |





**Spare porcelain/Ricambio porcellana : For/Per # 41311-00**

art.  
41311-AA



**Spare stand/Ricambio supporto : For/Per # 41311-00**

art.  
41311-AB



**Non slip feet/Piedini antiscivolo : For/Per # 41323**

|          |        |
|----------|--------|
| art.     | Pcs/Pz |
| 41323-AA | 6      |



**Folding lid/Coperchio a ribalta**

|          |       |
|----------|-------|
| art.     | Ø cm. |
| 41400-AB | 23,5  |
| 41405-AB | 13,5  |



**Cereal-bar glass/Barattolo cereali, vetro : For/Per # 42460-43; 42470-43**

|          |     |
|----------|-----|
| art.     | lt. |
| 41402-AA | 2   |



**Eutectic pad/Eutettico : For/Per # 41488**

|          |       |        |
|----------|-------|--------|
| art.     | Ø cm. | h. cm. |
| 41443-AE | 10,5  | 2      |



**Tray/Vassoio : For/Per # 41447-05**

art.  
41447-39



**Stoppers/Tappi pompa : For/Per # 41500-00**

|          |        |
|----------|--------|
| art.     | Pcs/Pz |
| 41500-AA | 2      |

**China cup/Porcellana : For/Per # 41563-07**

art.  
41563-AA

**China cup/Porcellana : For/Per # 41564-07,**

art.  
41564-AA

**Cheese jar/Vetro formaggiera : For/Per # 41638-01**

art. Ø cm.  
41638-91 10,5

**Spare parts/Ricambi : For/Per # 41638-02-04-12-13**

| art.     | des  | Ø cm. | h. cm. | lt. |
|----------|--|-------|--------|-----|
| 41638-92 | Oil/Winegar bottle/Ampolla olio/acetato            | 6     | 18,5   | 0,2 |
| 41638-93 | Salt shaker/Spargisale - Holes/Fori 6 Ø Mm 1,85    | 4     | 9      |     |
| 41638-94 | Pepper shaker/Spargipepe - Holes/Fori 18 Ø Mm 1,35 | 4     | 9      |     |
| 41638-95 | Toothpick holder/Porta stecchi                     | 4     | 9      |     |

**Brush/Spazzola : For/Per # 41767-20**

art.  
41767-AA

**Euthetic pad/Eutettico tondo**

art. Ø cm. h. cm.  
41910-AL 15 2,5

**Spare parts/Ricambi : For/Per # 41911**

art. des  
41911-AA Canister/Contentitore, SAN  
41911-AE Slide/Scivolo, SAN

**Cover/Tappo : For/Per # 42401**

art.  
42401-AA



**Cover/Tappo : For/Per # 42505**

art.  
42405-AA



**Set 10 blades/Set 10 lame : For/Per # 42520-00**

art.  
42520-AA



**Spare parts/Ricambi : For/Per # 42570-32**

| art.     | des              | mm. |
|----------|------------------|-----|
| 42570-91 | Disc/Griglia     | 1,5 |
| 42570-92 | Disc/Griglia     | 2,5 |
| 42570-94 | Disc/Griglia     | 4,0 |
| 42570-99 | Cranck/Manovella |     |



**Spare parts/Ricambi : For/Per # 42573-31**

| art.     | des              | mm. |
|----------|------------------|-----|
| 42573-91 | Disc/Griglia     | 1,5 |
| 42573-92 | Disc/Griglia     | 2,5 |
| 42573-94 | Disc/Griglia     | 4,0 |
| 42573-99 | Cranck/Manovella |     |



**Spare parts/Ricambi : For/Per # 42574-37**

| art.     | des              | mm. |
|----------|------------------|-----|
| 42574-90 | Disc/Griglia     | 1,0 |
| 42574-91 | Disc/Griglia     | 1,5 |
| 42574-92 | Disc/Griglia     | 2,0 |
| 42574-93 | Disc/Griglia     | 3,0 |
| 42574-94 | Disc/Griglia     | 4,0 |
| 42574-99 | Cranck/Manovella |     |



**Spare parts/Ricambi : For/Per # 42575-37**

| art.     | des              | mm. |
|----------|------------------|-----|
| 42575-90 | Disc/Griglia     | 1,0 |
| 42575-91 | Disc/Griglia     | 1,5 |
| 42575-92 | Disc/Griglia     | 2,0 |
| 42575-93 | Disc/Griglia     | 3,0 |
| 42575-94 | Disc/Griglia     | 4,0 |
| 42575-99 | Cranck/Manovella |     |



**Spare parts/Ricambi : For/Per # 42577-39**

| art.     | des              | mm. |
|----------|------------------|-----|
| 42577-90 | Disc/Griglia     | 1,0 |
| 42577-91 | Disc/Griglia     | 1,5 |
| 42577-92 | Disc/Griglia     | 2,0 |
| 42577-93 | Disc/Griglia     | 3,0 |
| 42577-94 | Disc/Griglia     | 4,0 |
| 42577-99 | Cranck/Manovella |     |

**Spare parts/Ricambi : For/Per # 42929-03**

| art.     | des   | Ø cm. | h. cm. |
|----------|---|-------|--------|
| 42929-AA | Pepper shaker/Spargipepe - Holes/Fori 6 Ø Mm 1,85 | 4     | 9      |
| 42929-AB | Salt shaker/Spargisale - Holes/Fori 18 Ø Mm 1,35  | 4     | 9      |
| 42929-AC | Oil/Winegar bottle/Ampolla olio/acetato           | 6     | 18,5   |

**Glass/Vetro : For/Per # 42939-15**

art.  
42939-AA

**Glass/Vetro lampada : For/Per # 42941-22**

art.  
42941-AA

**Wheel/Ruota : For/Per # 44023-00 # 44024-00**

art.  
44023-AA

**Dish separation grid /Griglia divisoria : For/Per # 44027-00**

art.  
44027-AA

**Eutectic pad/Piastra eutettica : For/Per # 44094R00**

| art.     | des         | dim. cm.  |
|----------|-------------|-----------|
| 44094-RE | Temp. -32°C | 13X23X3,5 |

**Sponge/Spugna : For/Per # 44101-03**

art.  
44101-AA





**Container/Contenitore : For/Per # 44103**

| art.     | des     |
|----------|---------|
| 44103-AA | 3 comp. |
| 44103-AB | 4 comp. |
| 44103-AC | 6 comp. |



**Flat mop/Frangia mop : For/Per # 44160-03**

| art.     |
|----------|
| 44160-AA |



**Trolley bags/Sacchi carrello : For/Per # 44174-24**

| art.     |
|----------|
| 44174-AA |



**Burner/Portacombustibile : For/Per # 44225-22; 44227-30**

| art.     |
|----------|
| 44220-AA |



**Cream puff nozzle/Beccuccio riempi bignè : For/Per # 47612-01**

| art.     |
|----------|
| 47612-AA |



**Knife insert/Inserto porta coltelli : For/Per # 48040-00 - 48040-10**

| art.     |
|----------|
| 48040-AA |



**Bone-saw blade/Lama per sega : For/Per # 48231**

| art.     | mm. |
|----------|-----|
| 48232-40 | 400 |
| 48232-45 | 450 |
| 48232-50 | 500 |



**Spare parts/Ricambi : For/Per # 49811-00**

| art.     | des                        |
|----------|----------------------------|
| 49811-01 | Cutting knife kit/Kit lama |
| 49811-02 | Blade/Lama                 |



**Spare parts/Ricambi : For/Per # 49812-00**

| art.     | des                                  |
|----------|--------------------------------------|
| 49812-01 | Blade and wheel/Lama e ruota dentata |
| 49811-02 | Blade/Lama                           |



**Spare parts/Ricambi : For/Per # 49814-00**

| art.     | des                                  |
|----------|--------------------------------------|
| 49811-02 | Blade/Lama                           |
| 49814-01 | Blade and wheel/Lama e ruota dentata |



**Spare parts/Ricambi : For/Per # 49818-00**

| art.     | des               | Ø cm. |
|----------|-------------------|-------|
| 49818-AC | Blade/Lama        | 7,4   |
| 49818-AD | Pusher/Pressatore | 7,4   |
| 49818-AE | Blade/Lama        | 10,2  |
| 49818-AF | Pusher/Pressatore | 10,2  |



**Set 7 blades/Set 7 lame : For/Per # 49829-11**

|          |
|----------|
| art.     |
| 49829-BA |



**Spare parts/Ricambi : For/Per # 49830-60**

| art.     | des                          |
|----------|------------------------------|
| 49830-00 | Slicer/Mandolino             |
| 49830-02 | Protective carriage/Carrello |
| 49830-AA | 38 Blades/Pettine 38 lame    |
| 49830-AB | 44 Blades/Pettine 44 lame    |
| 49830-AC | 60 Blades/Pettine 60 lame    |



**Spare parts/Ricambi : For/Per # 49832-10**

| art.     | des                           | mm. |
|----------|-------------------------------|-----|
| 49832-80 | Pusher/Pressatore             | 10  |
| 49832-86 | Pusher/Pressatore             | 6   |
| 49832-88 | Pusher/Pressatore             | 8   |
| 49832-90 | Blade/Lama                    | 10  |
| 49832-96 | Blade/Lama                    | 6   |
| 49832-98 | Blade/Lama                    | 8   |
| 49832-99 | Carriage/Guida di scorrimento |     |



**Spare parts/Ricambi : For/Per # 49834-00**

| art.     | des                          |
|----------|------------------------------|
| 49834-01 | Peeling blade/Lama a pelare  |
| 49834-02 | Slicing blade/Lama affettare |



**Spare parts/Ricambi : For/Per # 49835-00**

| art.     | des                          |
|----------|------------------------------|
| 49835-01 | Peeling blade/Lama a pelare  |
| 49835-02 | Slicing blade/Lama affettare |



**Blade assembly/Set lame : For/Per # 49837-05**

|          |
|----------|
| art.     |
| 49837-AA |



**Blade assembly/Set lame : For/Per # 49838-08**

art.  
49838-AB



**Corkscrew worm/Verme cavatappi : For/Per # 49858-00**

art.  
49858-AA



**Grinding wheel assembly/Set ruota molatrice : For/Per # 49872-00**

art.  
49870-AA



**Disc/Griglia : For/Per # 49879-37**

| art.     | mm. |
|----------|-----|
| 49879-90 | 1,0 |
| 49879-91 | 1,5 |
| 49879-92 | 2,0 |
| 49879-93 | 3,0 |
| 49879-94 | 4,0 |



**Pedal & opening assembly/Pedaliera e movimento : For/Per # 49899-01**

art.  
49899-AA



**Glass/Bicchieri : For/Per # 49956-01**

art.  
49956-AA



**Display for fry pans/Espositore per padelle ferro**

art.  
XO1046

# ALPHABETICAL INDEX

## INDICE ALFABETICO



|                                |                   |                                 |                           |                       |               |
|--------------------------------|-------------------|---------------------------------|---------------------------|-----------------------|---------------|
| <b>A</b>                       |                   |                                 |                           |                       |               |
| Absinthe spoon                 | 305               | Bone-saw                        | 162                       | Cake server           | 398           |
| Accessories for chafing dishes | 452>455           | Bordelais mold                  | 40                        | Cake slicer           | 195           |
| Acetate sheets                 | 201               | Boston shaker                   | 307                       | Cake stand dome cover | 281           |
| Adaptor bar                    | 60                | Bottle cooler                   | 363, 364                  | Cake/cheese tray      | 409           |
| Additional plate stand         | 104               | Bottle opener                   | 86, 91, 325               | Cake/pastry stand     | 279>283       |
| Adjustable brush               | 265               | Bottle pourer                   | 317                       | Can opener            | 86, 91, 123   |
| Agemono pot                    | 259               | Bottle rack                     | 321, 322                  | Can opener electric   | 517           |
| Air pot                        | 439               | Bottles and cans press          | 125                       | Can opener electric   | 125           |
| Airbrush                       | 192               | Bouillon cloth                  | 112                       | Candelabra            | 365, 366      |
| Airbrush compressor            | 192, 515          | Bowl double wall                | 442                       | Candleholder          | 366           |
| Airtight covers Weck           | 349               | Bowl holder chromed             | 431, 433                  | Candlestick           | 365, 366      |
| Almond past knife              | 179               | Bowl melamine                   | 402>404, 407>411, 431>432 | Canister              | 28            |
| Appetizers                     | 327>338           | Bowl/trays series black & brown | 344, 345                  | Canvas bag            | 427           |
| Apple corer                    | 88, 91            | Bowl/trays series clay          | 345, 346                  | Cappuccino milk pot   | 277           |
| Apple peeler                   | 115               | Bread basket                    | 42>427, 473               | Caramelising rod      | 192           |
| Artichoke corer                | 116               | Bread brush                     | 248                       | Caramelize electric   | 515           |
| Ashtray                        | 369, 370          | Bread cutting board             | 166, 411, 421, 429>430    | Card holder           | 367           |
| Asparagus peeler               | 86                | Bread knife                     | 138, 147                  | Cash tray             | 279           |
| Asparagus pot                  | 18                | Bread mold                      | 191, 246, 247             | Caviar cooler         | 362           |
| Asparagus tongs                | 398               | Bread proofing basket           | 248                       | Caviar flatware       | 362           |
| Automatic dispenser plug       | 322               | Bread roll-dispenser            | 420                       | Cereal dispenser      | 437>439       |
| Avocado peeler and slicer      | 116               | Bread sieve                     | 107                       | Cereal pitcher        | 437           |
| <b>B</b>                       |                   | Bread slicer                    | 419                       | Cereal-bar            | 437           |
| Bag clip                       | 112, 188          | Bread tongs                     | 397                       | Chafing dishes        | 444>449       |
| Bain-marie                     | 28, 33, 40        | Breakfast tray with legs        | 461                       | Chainmail glove       | 166           |
| Baking beans                   | 201               | Broom w/dust pan                | 460                       | Chalkmarker           | 287, 368, 427 |
| Baking paper                   | 200               | Brussel sprout cutter           | 116                       | Champagne glass       | 298           |
| Baking sheet trolley           | 484, 485          | Bucket with wringer             | 490                       | Champagne saber       | 365           |
| Baking sheet, silicone         | 200, 201          | Buffet box acacia               | 420 421                   | Champagne stopper     | 323           |
| Baking tray                    | 190, 191, 272>274 | Buffet display                  | 413, 414                  | Champagne tongs       | 365           |
| Balti pan                      | 260               | Buffet display and presentation | 401>439                   | Champagne Waterfall   | 416           |
| Bar                            | 297>326           | Buffet ladder                   | 434, 435                  | Changing table        | 486           |
| Bar liner                      | 319               | Buffet stand                    | 411, 412, 432, 433        | Cheese jar            | 357           |
| Bar organizer                  | 315               | Buffet wire stand               | 426, 427                  | Cheese knife          | 151           |
| Barbecue brush                 | 103               | Butchers table                  | 165                       | Cheese rotary grater  | 117           |
| Barman apron                   | 320               | Butter churn                    | 121                       | Cheese shaker         | 357           |
| Barman's case                  | 320               | Butter cup                      | 352                       | Cheese slicer         | 85, 89        |
| Basket with wire stand         | 426               | Butter curler                   | 92, 87                    | Cheese wire cutter    | 118           |
| Baster tube                    | 102               | Butter mold                     | 121                       | Chef's torch          | 193           |
| Basting brush                  | 85, 90            | Butter spreader                 | 85, 90                    | Cherry core stripper  | 118           |
| Basting spoon                  | 100               | <b>C</b>                        |                           | Chestnut knife        | 84            |
| Bento box                      | 252               | Cake and cheese trolley         | 459                       | Chinese colander      | 111, 112      |
| Big party tub                  | 416               | Cake frames                     | 204, 205                  | Chinese hot pot       | 260           |
| Bill spike                     | 103               | Cake marker                     | 197                       | Chinese meat cleaver  | 149           |
| Bird nest fryer                | 100               | Cake molds non stick coating    | 209>211, 213, 214         | Chinese spoon         | 254           |
| Blender                        | 507               | Cake peel                       | 189                       | Chocolate bars mold   | 223           |
| Blinis pan                     | 33, 35, 42        | Cake plate, swivel base         | 189                       | Chocolate fountain    | 415, 513      |
|                                |                   | Cake ribbon (PET)               | 201                       | Chopstick rest        | 255           |
|                                |                   | Cake ring, microperforated      | 203                       | Chopsticks            | 255, 256      |
|                                |                   |                                 |                           | Cigar humidor         | 370           |

|  |              |                                   |          |                          |                 |
|--|--------------|-----------------------------------|----------|--------------------------|-----------------|
| Cigar scissors                               | 370          | Cream chargers                    | 296      | Duck fur pincer          | 262             |
| Citrus bar knife                             | 87           | Cream dispenser                   | 192      | Dumplin maker            | 123             |
| Citrus fruit squeezer electric               | 506>508      | Cream roll/horn molds             | 187      | Dunnage rack             | 493             |
| Citrus stripper                              | 88           | Cream whipper                     | 295      | Dust beater V sweeper    | 488             |
| Clay pot                                     | 261          | Crème caramel                     | 205      | Dust cover               | 469             |
| Cleaning system, Pulse                       | 488          | Crepe machine                     | 498      | Dustpan                  | 488             |
| Cleaning wand                                | 488          | Crepe spreader                    | 101      | <b>E</b>                 |                 |
| Clip tags for dish racks                     | 467          | Crepes pan                        | 32, 33   | Eclairs mold             | 245, 246        |
| Cocktail fountain                            | 415          | Croissant cutter                  | 196      | Egg basket               | 427             |
| Cocktail jigger                              | 305          | Cube cutter                       | 114      | Egg container            | 116             |
| Cocktail spoon                               | 92, 304      | Cut resistant glove               | 167      | Egg cup                  | 352             |
| Cocktail strainer                            | 305          | Cutlery dispenser                 | 357, 430 | Egg dish                 | 50              |
| Cocoa dredger                                | 277          | Cutlery holder                    | 467, 468 | Egg knocker              | 115             |
| Cocoa stencils                               | 276          | Cutlery rack                      | 467      | Egg mold                 | 224             |
| Coffee measuring spoon                       | 92           | Cutter & vegetable slicer         | 505      | Egg rings                | 116             |
| Coffee percolator                            | 451, 511     | Cutting board HDPE                | 164, 165 | Egg separator            | 92              |
| Coffee set                                   | 280          | Cutting board rack                | 166      | Egg wedger               | 115             |
| Coffee shop                                  | 275>284      | <b>D</b>                          |          | Eggs boiler              | 498             |
| Coffee urn                                   | 450          | Dash bottle                       | 316, 317 | Electric appliances      | 496>517         |
| Cognac warmer                                | 365          | Decorating combs                  | 198      | Emulsifier-mixer         | 505             |
| Colander                                     | 108, 109     | Decorating spoons                 | 107, 179 | Escargot dish            | 361             |
| Collapsible frame                            | 486          | Decorating tips for cream whipper | 295      | Escargot fork            | 400             |
| Condiment holder                             | 319          | Decoration tools                  | 120      | Escargot picks           | 361             |
| Condiment set                                | 356, 357     | Dehydrator                        | 501      | Ethnic cuisine           | 249>262         |
| Confectionery funnel                         | 191          | Digital timer                     | 131      | Eutectic pad             | 430, 476        |
| Contact grill                                | 496          | Dim Sum steam rack                | 259      | Expanding pastry cutter  | 196             |
| Cookie press                                 | 188          | Dipping forks                     | 179, 359 | <b>F</b>                 |                 |
| Cooking tongs                                | 102, 103     | Dish dolly                        | 467      | Fast food tray           | 480, 481        |
| Cookware enamelled cast iron                 | 43>48        | Dish oval melamine                | 403      | Fingesfood porcelain     | 337, 338        |
| Cookware series 1000 stainless steel         | 14>16        | Dish racks                        | 466, 467 | Fish & chips spatula PA+ | 80              |
| Cookware series 1100 stainless steel         | 10>12        | Dish-warmer                       | 500      | Fish kettle              | 27, 33, 40      |
| Cookware series 12300 3-ply                  | 441          | Display tray                      | 199, 200 | Fish scaler              | 84, 85, 88, 262 |
| Cookware series 12300 3-ply                  | 441          | Disposable baker's blades         | 248      | Fish-bone remover        | 102             |
| Cookware series 15200 copper 3-ply mini pans | 38           | Disposable covers                 | 481      | Flair bottle             | 315             |
| Cookware series 15300-15400 tinned copper    | 39, 40       | Disposable forks & spoons         | 326      | Flambé trolley           | 457, 458        |
| Cookware series 15500 copper 3-ply induction | 36, 37       | Dollies                           | 189      | Flavour marker           | 287, 288        |
| Cookware series 16130 aluminum mini pans     | 41           | Dolly for cases                   | 484      | Flexipan baking sheets   | 232>247         |
| Cookware series 2000 stainless steel         | 17>19        | Dolly for PPE containers          | 476      | Floor sign               | 489             |
| Cookware series 2100 stainless steel         | 13           | Dolly with handle                 | 468      | Floor standing ashtray   | 493             |
| Cookware series 2500 3-ply                   | 23>25        | Dome cover                        | 358      | Flour brush              | 199             |
| Cookware series 6100 aluminum                | 29>33        | Dough box                         | 271      | Flour scoop              | 107             |
| Cookware series Gluten Free stainless steel  | 21, 518, 519 | Dough cutter                      | 271      | Flour sieve              | 107             |
| Cookware, pots & pans                        | 10>48        | Dough plunger cutters w/extractor | 178, 179 | Flour sifter             | 199             |
| Cool bowl                                    | 431>432      | Dough scraper                     | 198, 271 | Flower vase              | 365             |
| Cooled buffet showcase                       | 429, 430     | Drainer                           | 231      | Foil cutter              | 324             |
| Counter showcase                             | 283, 284     | Drainer plate                     | 60       | Folding ladder           | 493             |
| Couscous pan                                 | 30           | Draining rack                     | 190      | Fondue set               | 40, 359         |
| Cover clamps Weck                            | 349          | Drawer                            | 407      | Food container           | 471, 472, 478   |
| Cover for bowls                              | 431          | Drink mixer                       | 508      |                          |                 |
| Cover for bread basket                       | 425          |                                   |          |                          |                 |

|   |               |                           |                       |                                |          |
|---|---------------|---------------------------|-----------------------|--------------------------------|----------|
| Food-grade resin spatula                | 103           | Grater                    | 85, 90, 118, 122, 123 | Icing bags & nozzles wall rack | 189      |
| Foodloops                               | 113           | Gravity slicing machine   | 515                   | Icing sugar sieve              | 199      |
| Forged knives                           | 136>138       | Griddle plate             | 46                    | Induction adapter              | 110      |
| Free flow pourer                        | 322           | Grill pan                 | 45                    | Induction cooker               | 453, 511 |
| French fry cutter                       | 117           | Gueridon trolley          | 457                   | Infrared lamp                  | 502      |
| French fry scoop                        | 101           | Guitar                    | 195                   | Ingredient bin                 | 472      |
| French press                            | 350           | <b>H</b>                  |                       | Insulated beverage server      | 349, 350 |
| French stick bread basket               | 423           | Ham boner                 | 151                   | Insulated container            | 475>478  |
| Fruit basket                            | 311, 312, 353 | Ham knife                 | 137, 143              | Insulated dispenser            | 439      |
| Fruit stand                             | 415, 433, 434 | Ham stand                 | 162                   | <b>J</b>                       |          |
| Fry basket                              | 60, 262       | Ham tongs                 | 161                   | Jam bar                        | 437      |
| Fry dripping tray                       | 27            | Hamburger press           | 163                   | Japanese sushi knives          | 155, 156 |
| Fryer                                   | 499           | Hand roll stand           | 252                   | Jar opener                     | 90       |
| Frying oil tester                       | 131, 132      | Hangiri/sushi rice tub    | 258                   | Jelly fuel                     | 455      |
| Frying pans steel                       | 34, 35        | Heat accumulator          | 476                   | Juice dispenser                | 438, 439 |
| Fuel Holder                             | 454           | Heating units electric    | 455                   | Juice extractor                | 504, 506 |
| Funnel                                  | 105           | Herb mill                 | 124                   | Juice pitcher                  | 350, 351 |
| <b>G</b>                                |               | Herb scissors             | 117                   | Julep mug                      | 300, 301 |
| Ganache frame set                       | 195           | Herbs/chili mill          | 385                   | Julep strainer                 | 305      |
| Garlic press                            | 90, 118       | Honey/cream dispenser     | 277                   | <b>K</b>                       |          |
| Gastronorm basket                       | 473           | Hors d'oeuvre trolley     | 458                   | Kaiser bread marker            | 248      |
| Glass bowl                              | 431           | Hot dog heater            | 498                   | Kebab/Gyros grill              | 498      |
| Glass cleaning brush                    | 321           | Housekeeping cart         | 487                   | Kitchen utensils               | 78>135   |
| Glass clip holder                       | 326           | Hydrometer for brine/salt | 131                   | Kitchen utensils PA+           | 79>82    |
| Glass rack                              | 321           | Hygienic cover            | 422                   | Kitchenbowl                    | 108      |
| Glass rimmer                            | 319           | <b>I</b>                  |                       | Knife block                    | 158, 159 |
| Glasses                                 | 308>311       | Ice bucket                | 315, 478              | Knife case                     | 157      |
| Glasses Weck                            | 347, 348, 349 | Ice cart                  | 478                   | Knife roll-bag                 | 158      |
| GLUTEN FREE products                    | 518>523       | Ice chisel                | 121                   | Knife sanitizing system        | 159      |
| GN baking sheets aluminum/non stick     | 58            | Ice cream basin           | 286                   | Knife sharpener electric       | 517      |
| GN food pans                            | 51>77         | Ice cream cone holder     | 288>290               | Knife sterilizer               | 517      |
| GN food pans induction porcelain        | 76, 77        | Ice cream container       | 286                   | Knives                         | 136>158  |
| GN food pans melamine                   | 72, 73        | Ice cream counter display | 294                   | <b>L</b>                       |          |
| GN food pans PC                         | 61, 62        | Ice cream cup             | 290>292               | Labels                         | 132, 133 |
| GN food pans porcelain                  | 74, 75        | Ice cream maker           | 500                   | Ladle                          | 100      |
| GN food pans PP                         | 67>71         | Ice cream mold            | 293, 294              | Ladle PA+                      | 80, 81   |
| GN food pans stainless steel            | 52>58         | Ice cream scoop           | 91, 287               | Lanterns                       | 418      |
| GN food pans Tritan                     | 63, 64        | Ice cream server          | 286                   | Led candles                    | 367, 418 |
| GN hermetic lids with overmolded GASKET | 69            | Ice crusher electric      | 507                   | Lemon squeezer                 | 312      |
| GN-baking sheets                        | 58, 59        | Ice crusher manual        | 313                   | Lever dispenser                | 106      |
| GN-containers non stick coated          | 55            | Ice knife                 | 121                   | Lightning column               | 413      |
| GN-containers, falling handles          | 55            | Ice molds                 | 314                   | Liquidiser                     | 503, 504 |
| GN-containers, fixed handles            | 53, 54        | Ice pick                  | 313                   | Lobster cracker                | 361      |
| GN-containers, internal handles         | 54            | Ice scoop                 | 313, 478              | Lobster forks                  | 361      |
| GN-lid with silicone seal               | 62            | Ice tongs                 | 315, 398              | Lobster pick                   | 361      |
| GN-lids                                 | 57            | Ice-box                   | 429                   |                                |          |
| GN-lids, hermetic                       | 64            | Ice-Cream                 | 285>296               |                                |          |
| Graduated bucket                        | 109, 490      | Icing bag                 | 187, 188              |                                |          |
| Grapefruit knife                        | 87, 91        | Icing bag holder          | 189                   |                                |          |

|                                   |                    |  |
|-----------------------------------|--------------------|--|
| <b>M</b>                          |                    |  |
| Magnetic knife rack               | 159                |  |
| Mandoline                         | 118, 119           |  |
| Manual sharpener                  | 159                |  |
| Manual slicing machine - Flywheel | 163                |  |
| Marinating syringe                | 102                |  |
| Martini/margarita cup             | 298                |  |
| Measuring jug                     | 105                |  |
| Measuring pourer                  | 323                |  |
| Meat cleaver                      | 149, 150           |  |
| Meat fork                         | 100, 138, 151      |  |
| Meat hooks                        | 160, 161           |  |
| Meat mincer electric              | 515                |  |
| Meat pan                          | 162                |  |
| Meat tenderizer                   | 161, 162           |  |
| Mechanical sweeper                | 488                |  |
| Melon baller                      | 86, 91             |  |
| Melon peeler                      | 87                 |  |
| Menu stand                        | 367                |  |
| Microfibre cloth                  | 489                |  |
| Microfibre mops                   | 488                |  |
| Microwave oven                    | 509                |  |
| Milk dispenser                    | 438, 439           |  |
| Milk pot with lid                 | 277                |  |
| Mincing knife                     | 151                |  |
| Minibar restocking cart           | 483                |  |
| Mirrors                           | 417                |  |
| Mixer/liquidiser combi unit       | 503                |  |
| Mixing bowl                       | 40, 108, 110       |  |
| Mixing glass                      | 308                |  |
| Mobile pedal bin                  | 492                |  |
| Mobile plate rack                 | 479                |  |
| Moisture bottle                   | 199                |  |
| Mooncake mould                    | 256                |  |
| Mop holder                        | 489                |  |
| Mopping trolley with press        | 490                |  |
| Mortar and pestle                 | 261                |  |
| Moscow mule mug                   | 298>300            |  |
| Mozzarella/tomato cutter          | 113                |  |
| Muddler                           | 313                |  |
| Multi rack                        | 435, 436           |  |
| Multifunction oven                | 499                |  |
| Mushroom cutter                   | 116                |  |
| Mussel pot                        | 360                |  |
| Mustard cup                       | 352                |  |
| <b>N</b>                          |                    |  |
| Napkin holder                     | 278, 279, 358      |  |
| Newspaper stick                   | 368                |  |
| Nigiri mold                       | 257                |  |
| Nitro Whip                        | 276                |  |
| Nozzles                           | 180>186            |  |
| Nut-cracker                       | 361                |  |
| Nutmeg grater                     | 123                |  |
| Nutmeg mill                       | 383, 386           |  |
| <b>O</b>                          |                    |  |
| Octopus-press                     | 113                |  |
| Odor eliminator soap bar          | 92                 |  |
| Oil pourer                        | 261, 264           |  |
| Oil/vinegar sprayer               | 356                |  |
| One piece basting spoon           | 98, 99             |  |
| One piece ladle                   | 98, 99             |  |
| One piece meat fork               | 98, 99             |  |
| One piece skimmer                 | 99, 100            |  |
| One piece spatula                 | 99                 |  |
| One-hand mincing knife            | 84                 |  |
| Orange juicer manual              | 312                |  |
| Orange peeler                     | 87, 91             |  |
| Oven dishes                       | 50                 |  |
| Oven dishes APPOLIA PEUGEOT       | 388>395            |  |
| Oven mitt                         | 166, 167           |  |
| Oyster fork                       | 399                |  |
| Oyster knife                      | 84, 90, 150        |  |
| Oyster plate                      | 415                |  |
| Oyster tray                       | 362                |  |
| <b>P</b>                          |                    |  |
| Pallet                            | 493                |  |
| Pan gripper                       | 267                |  |
| Paper napkins holder              | 288                |  |
| Paring knife                      | 89, 138, 146       |  |
| Parmesan cheese knife             | 84, 89, 150        |  |
| Party plate                       | 403                |  |
| Party spoon                       | 405                |  |
| Pastry brush                      | 198                |  |
| Pastry cutters PA+                | 178                |  |
| Pastry cutters stainless steel    | 169>177            |  |
| Pastry utensils                   | 168>248            |  |
| Pastry wheel                      | 84, 88, 196        |  |
| Peeling machine                   | 115, 501           |  |
| Pepper/salt mill PEUGEOT          | 374>385            |  |
| Perforated GN-containers          | 56                 |  |
| Pie knife                         | 151                |  |
| Pie server                        | 96                 |  |
| Piepans aluminum                  | 206                |  |
| Pineapple coring tool             | 86                 |  |
| Pineapple cup                     | 298                |  |
| Pineapple-peeler/corer            | 114                |  |
| Pinneapple slicer                 | 115                |  |
| Piping tip adapter                | 186                |  |
| Pizza cutter                      | 267                |  |
| Pizza delivery bag                | 269, 270           |  |
| Pizza items                       | 263>274            |  |
| Pizza pan                         | 272, 273           |  |
| Pizza pan rack                    | 272                |  |
| Pizza peel                        | 264>267            |  |
| Pizza screen                      | 272                |  |
| Pizza wheel                       | 84, 88, 267        |  |
| Planetary mixer                   | 509                |  |
| Plate cover                       | 104, 433           |  |
| Plate melamine                    | 402, 404, 406, 408 |  |
| Plate warmer                      | 360                |  |
| Platform cart                     | 484                |  |
| Pocket crumbler                   | 358                |  |
| Polycarbonate Christmas molds     | 225                |  |
| Polycarbonate Easter molds        | 225                |  |
| Portion rings                     | 112                |  |
| Potato fork                       | 91                 |  |
| Potato masher                     | 90                 |  |
| Potato peeler                     | 87, 91, 117        |  |
| Potato ricer                      | 117                |  |
| Poultry shears                    | 152                |  |
| Pourer                            | 365                |  |
| Praline's polycarbonate molds     | 217>223            |  |
| Praline's silicone molds          | 216                |  |
| Presse canard                     | 113                |  |
| Pretzel stand                     | 422                |  |
| Protective apron                  | 166                |  |
| Pumpkin mug                       | 298                |  |
| Punch bowl                        | 416                |  |
| <b>R</b>                          |                    |  |
| Raclette maker                    | 359, 513           |  |
| Rapid infusion kit                | 296                |  |
| Reception bell                    | 368                |  |
| Refrigerated box                  | 463, 480           |  |
| Refuse bag holder trolley         | 492                |  |
| Retractable barrier set           | 494                |  |
| Rice bowl                         | 250, 252           |  |
| Rice scoop                        | 112                |  |
| Rice spoon                        | 257                |  |
| Rice steamer                      | 508                |  |
| Roast beef/stew trolley           | 457                |  |
| Roasting pan                      | 27                 |  |
| Roll holder                       | 104, 481           |  |
| Rolling pin                       | 197                |  |
| Roll-top cover                    | 425, 428>430       |  |
| Room service table                | 463, 464           |  |



|                              |                    |                              |                    |  |          |
|------------------------------|--------------------|------------------------------|--------------------|--|----------|
| Room service tray            | 461                | Silicone molds               | 226>231            | Store & pour container                 | 317, 318 |
| Room serving trolley         | 462, 464           | Sink trolley                 | 472                | Strainer                               | 109, 111 |
| Rouet                        | 120                | Skewers                      | 160, 256, 325, 326 | Strainer PA+                           | 82       |
| Rubber comb, wood effect     | 214                | Skimmer                      | 100, 101           | Straw holder                           | 278      |
| Rubber rings Weck            | 349                | Skimmer PA+                  | 80, 81             | Straws                                 | 302, 303 |
| Ruler                        | 194                | Slotted turner               | 100                | Straws case                            | 289      |
| Runner                       | 341                | Smoker                       | 501                | String holder                          | 162      |
| <b>S</b>                     |                    | Smoking chips                | 316                | String mop                             | 489      |
| Safety chain for floor signs | 489                | Smoking gun                  | 315                | Sturdy chair                           | 486      |
| Sake cup                     | 254                | Smoking gun dome cover       | 316                | Sugar bulb                             | 193      |
| Sake jug                     | 254                | Smoother                     | 194                | Sugar dredger                          | 199      |
| Sake warmer                  | 254                | Snack holder                 | 327, 328           | Sugar gloves                           | 167      |
| Salad bowl                   | 353                | Snail tongs                  | 396                | Sugar lamp                             | 193, 514 |
| Salad bowl melamine          | 406                | Soda chargers                | 313                | Sugar packet holder                    | 278      |
| Salad spinner                | 111                | Soda siphon                  | 313                | Sugar pourer                           | 277      |
| Salamander                   | 497                | Soufflé pot                  | 44, 48             | Sugar saucepan                         | 40       |
| Salami pricker               | 159                | Soup bowl, lion-headed       | 353                | Sugar tongs                            | 398      |
| Salmon knife                 | 137, 143, 145      | Soup kettle electric         | 452, 513           | Sushi geta board                       | 252      |
| Salt tester                  | 131                | Sous-vide cooking device     | 510                | Sushi mat                              | 257      |
| Salt/pepper shaker           | 355                | Soy pot                      | 254                | Sushi-sashimi boat                     | 253      |
| Samovar                      | 450, 451, 512      | Space saving box             | 473                | Sushi-sashimi bridge                   | 252      |
| Sandwich board               | 368                | Spaghetti spoon              | 100                | Swivelling table top rack              | 479      |
| Sauce boat                   | 352                | Spaghetti tongs              | 397                | Syrup density meter                    | 194      |
| Sauce bowls melamine         | 335                | Spare parts                  | 524>532            | Syrup hydrometer                       | 131      |
| Sauce ladle                  | 100                | Spatulas PA+                 | 79                 | <b>T</b>                               |          |
| Sauce pot                    | 334                | Spatzle sieve                | 123                | Table accessories series Natural slate | 342, 343 |
| Sauce pourer                 | 253                | Speed rack                   | 103, 321           | Table bag holder                       | 363      |
| Saucepot platter             | 44                 | Spiked roller                | 196                | Table barbecue                         | 46, 360  |
| Saucepot stand               | 44                 | Spits, disposable            | 326                | Table bread basket                     | 353, 354 |
| Scales                       | 133>135            | Spoon and cup holder         | 277, 289           | Table caddy                            | 357      |
| Scissors                     | 153, 154           | Spoon mold                   | 223                | Table cigar cutter                     | 369      |
| Scrubbing gloves             | 167                | Spoon PA+                    | 79                 | Table crumbler                         | 358      |
| Sea urchin cutter            | 361                | Spray gun                    | 192                | Table mat                              | 341      |
| Seafood display rack         | 362                | Spray gun                    | 514                | Table number stand                     | 367      |
| Segment colander             | 28                 | Spraying bottle              | 199                | Table sign                             | 367      |
| Serving board melamine       | 408                | Squeeze bottle               | 106, 107           | Table top                              | 339>370  |
| Serving boards               | 330>334            | Stackable container          | 473, 474           | Table top can opener                   | 125      |
| Serving box                  | 346                | Stamped knives               | 139>147            | Table top waste bin                    | 361      |
| Serving stand                | 312, 402, 432, 436 | Stand with grill stone       | 359                | Table with hot box                     | 480, 503 |
| Serving tongs                | 102                | Stand/basket                 | 413                | Table-cloth clips                      | 358      |
| Serving trolley 2/3 tiers    | 482, 483, 487      | Steak knife                  | 138, 145, 146      | Table-top cutter                       | 501, 505 |
| Shaker                       | 306, 307           | Steamer                      | 257, 261           | Tamagoyaki pan                         | 260      |
| Sharpening steel             | 152                | Steamer electric             | 509                | Tart mold                              | 211, 212 |
| Sharpening stone             | 152                | Stencils                     | 216                | Tart ring                              | 202      |
| Showplate buffet set         | 428, 429           | Step on bin                  | 492                | Tasting bowls/glasses                  | 335, 336 |
| Sieve electric               | 517                | Sticky rice lao pot          | 258                | Tasting/dessert set                    | 328, 329 |
| Sieve for flour              | 199                | Stirrers                     | 303, 304           | Tawa pan                               | 260      |
| Sign holders                 | 367, 427           | Storage box                  | 470                | Tea strainer                           | 352      |
| Silicone baking sheet        | 201                | Storage canister             | 318                | Tea-box                                | 278      |
|                              |                    | Storage, transport, cleaning | 468>494            |  |          |

|  |                    |                                |                  |
|--|--------------------|--------------------------------|------------------|
| Teapot                                 | 254, 255           | Vegetable preparation machine  | 504              |
| Telescopic door sign                   | 490                | Vegetable sharpener            | 85               |
| Telescopic rod                         | 489                | Vegetable sieve                | 111, 124         |
| Tempering unit                         | 193, 294, 295, 514 | Ventilated warming display     | 500              |
| Tempura rack                           | 259                | Vertical manual sausage filler | 163              |
| Thai knife                             | 120                | Vertical slicing machine       | 516              |
| Thermic hot box                        | 463, 480           | Vinyl bag                      | 487              |
| Thermo cover                           | 479                | <b>W</b>                       |                  |
| Thermohygrometer                       | 131                | Waffle case                    | 289              |
| Thermometers                           | 126>132            | Waffle iron                    | 501, 502         |
| Thermoregulator                        | 455                | Waiter's corkscrew             | 324              |
| Tickets-holder                         | 103                | Waiter's corkscrew case        | 325              |
| Tiki mug                               | 301, 302           | Wall board                     | 368              |
| Tilt truck                             | 492                | Wall clock                     | 133              |
| Toast rack                             | 352                | Wall draining rack             | 469              |
| Toaster                                | 496                | Wall film box                  | 104              |
| Toban skillet                          | 259                | Wall rack                      | 100              |
| Tomato cutter                          | 114                | Wall rack for icing bags       | 189              |
| Tomato juicer sieve                    | 124                | Wall rack for nozzles          | 189              |
| Tomato peeler                          | 87                 | Warming display                | 500              |
| Tongs and serving pliers series Living | 397>400            | Warming plate                  | 503              |
| Tongs PA+                              | 80                 | Wasabi grater                  | 261              |
| Toothpicks                             | 326                | Waste container                | 490, 491         |
| Tortillas cup                          | 48                 | Water boiler with tap          | 509              |
| Tortillas wedger                       | 117                | Water jug                      | 310, 350, 351    |
| Towel tray                             | 252                | Weck glasses serving stand     | 349              |
| Tray stainless steel                   | 418, 419           | Wedding cake stand             | 415              |
| Tray stand                             | 418                | Wedger                         | 114, 115         |
| Tray with dome cover                   | 355                | Wet mop handles                | 488              |
| Trays & bowls melamine series Thara    | 250, 251           | Whisk                          | 100, 103         |
| Trays melamine                         | 403, 404, 407, 410 | Whisk PA+                      | 82               |
| Trivet                                 | 360                | Whistling kettle               | 27               |
| Trolley 3 levels                       | 469                | Wine bucket                    | 363              |
| Trolley convertible                    | 484                | Wine bucket table clip         | 363              |
| Trolley Quick Cart                     | 486                | Wine collar                    | 365              |
| Trolleys                               | 457>464            | Wine cooler stand              | 363              |
| Truffle server                         | 355                | Wine holder                    | 364              |
| Truffle-slicer                         | 355                | Wine stopper                   | 323              |
| Trussing needle                        | 160                | Wine taster                    | 365              |
| Turners                                | 95, 96             | Wine/liqueur trolley           | 460              |
| Tweezer                                | 304                | Winged corkscrew               | 324              |
| <b>U</b>                               |                    | Wire dish rack                 | 469              |
| Universal tray collector trolley       | 481                | Wire grid                      | 60               |
| Utility rack GN                        | 481>483            | Wok                            | 24, 35, 258, 259 |
| <b>V</b>                               |                    | Wok brush                      | 262              |
| Vacuum pump wine preserver             | 324                | Wonton noodle skimmer          | 262              |
| Vegetable cutter                       | 114, 119, 120      | Wooden buffet stand            | 436              |
| Vegetable knife                        | 84                 | Wooden stand                   | 436              |
|  |                    | Zabaione bowl                  | 40               |
|  |                    | Zester                         | 88, 92           |
|  |                    | Zippered plastic cover         | 479              |
|  |                    | Zucchini corer                 | 86, 91           |

|   |               |  |               |
|---|---------------|--|---------------|
| <b>A</b>                                  |               | <b>B</b>                               |               |
| Accessori chafing dish                    | 453>455       | Bacchette cinesi                       | 255, 256      |
| Accessori tavola serie ardesia naturale   | 342, 343      | Bacinella carré                        | 191           |
| Acciaino                                  | 152           | Bacinella conica                       | 108           |
| Accumulatore freddo/caldo                 | 430, 476      | Bacinella per gelato                   | 286           |
| Acetato in fogli                          | 201           | Bagnomaria                             | 28, 33, 40    |
| Adattatore induzione                      | 110           | Bar                                    | 297>326       |
| Adattatore per bocchette                  | 186           | Barbecue da tavola                     | 46, 360       |
| Affetta formaggio                         | 85, 89        | Barca per sushi e sashimi              | 253           |
| Affetta mozzarella/pomodori               | 113           | Barra magnetica                        | 159           |
| Affetta pomodori                          | 114           | Bastardella                            | 40, 108, 110  |
| Affettatrice a gravità                    | 515           | Batticarne                             | 161, 162      |
| Affettatrice manuale                      | 163           | Benna ribaltabile                      | 492           |
| Affettatrice verticale                    | 516           | Bento box                              | 346           |
| Affilacoltelli elettrico                  | 517           | Bicchiere miscelatore                  | 308           |
| Affilacoltelli manuale                    | 159           | Bicchieri                              | 308>311       |
| Affumicatoio                              | 501           | Bicchierini/ciotoline degustazione     | 335, 336      |
| Affumicatore                              | 315           | Bilance                                | 133>135       |
| Ago da cucina                             | 160           | Bistecchiera                           | 45            |
| Alzata 2/3 piani                          | 312, 436      | Bocchette                              | 180>186       |
| Alzata buffet                             | 410           | Bocchette per sifone panna             | 295           |
| Alzata cromata                            | 411, 432, 433 | Bollitore                              | 27            |
| Alzata frutta                             | 415           | Bollitore con rubinetto                | 509           |
| Alzata legno                              | 436           | Bollitore uova                         | 498           |
| Alzata torta/dolci                        | 279>283, 415  | Bordatore bicchieri                    | 319           |
| Alzata/cesto                              | 413           | Borsa isoterma                         | 269, 270      |
| Amuse-bouche                              | 327>338       | Boston shaker                          | 307           |
| Anelli per impiattare                     | 112           | Bottiglia angostura                    | 316, 317      |
| Anelli per uova                           | 116           | Box portaghiaccio                      | 429           |
| Anello distanziatore                      | 104           | Box refrigerato                        | 463, 480      |
| Anello per torte                          | 202           | Box termico                            | 463, 480      |
| Aperitivo/degustazione set                | 328, 329      | Brasiera                               | 27            |
| Apparecchi elettrici                      | 496>517       | Buffet e presentazione                 | 401>439       |
| Apparecchio cottura sottovuoto            | 510           | <b>C</b>                               |               |
| Apribarattoli                             | 90            | Caffetteria                            | 275>284       |
| Apriscatole                               | 86, 91, 123   | Caffettiera pressa filtro              | 350           |
| Apriscatole da banco                      | 125           | Campana per alzata torta               | 281           |
| Apriscatole elettrico                     | 125, 517      | Campanella reception                   | 368           |
| Apriuovo                                  | 115           | Candelabro                             | 365, 366      |
| Arricciaburro                             | 92, 87        | Candele led                            | 367, 418      |
| Articoli GLUTEN FREE                      | 518>523       | Candeliere                             | 365, 366      |
| Aspirapolvere meccanico                   | 488           | Cannello                               | 193           |
| Asta per mestolame                        | 100           | Cannoli/cornetti                       | 187           |
| Asta portascontrini                       | 103           | Cannucce                               | 302, 303      |
| Aste delimita corsie a nastro estensibile | 494           | Cannula disosso                        | 151           |
| Attrezzi decoro                           | 120           | Caraffa                                | 310, 350, 351 |
|   |               | Caraffa cereali                        | 437           |
|   |               | Caraffa graduata                       | 105           |
|   |               | Caraffa sake                           | 254           |
|   |               | Caraffa termica                        | 349, 350, 439 |
|   |               | Caramellizzatore                       | 192, 515      |
|   |               | Carapina                               | 286           |
|   |               | Carrelli sala                          | 457>464       |
|   |               | Carrello 3 piani                       | 469           |
|   |               | Carrello antipasti                     | 458           |
|   |               | Carrello arrostiti/bolliti             | 457           |
|   |               | Carrello con maniglione                | 468           |
|   |               | Carrello convertibile                  | 484           |
|   |               | Carrello di servizio 2/3 piani         | 482, 483, 487 |
|   |               | Carrello dolci-formaggi                | 459           |
|   |               | Carrello flambé                        | 457, 458      |
|   |               | Carrello GN                            | 481>483       |
|   |               | Carrello gueridon                      | 457           |
|   |               | Carrello lavapavimenti con strizzatore | 490           |
|   |               | Carrello liquori/vini                  | 460           |
|   |               | Carrello per contenitori PPE           | 476           |
|   |               | Carrello per derrate alimentari        | 472           |
|   |               | Carrello porta cassette                | 484           |
|   |               | Carrello porta ghiaccio                | 478           |
|   |               | Carrello porta piatti                  | 479           |
|   |               | Carrello porta teglie                  | 482, 483      |
|   |               | Carrello portabiancheria               | 487           |
|   |               | Carrello portapiatti                   | 469           |
|   |               | Carrello portasacco                    | 492           |
|   |               | Carrello Quick Cart                    | 486           |
|   |               | Carrello rifornimento frigobar         | 483           |
|   |               | Carrello ritiro vassoi universale      | 481           |
|   |               | Carrello servizio in camera            | 462, 464      |
|   |               | Carrello trasporto materiali           | 484           |
|   |               | Carrello vasca                         | 472           |
|   |               | Carta da forno                         | 200           |
|   |               | Cascata champagne                      | 416           |
|   |               | Casseruola Agemono                     | 259           |
|   |               | Casseruola terracotta                  | 261           |
|   |               | Casseruola zabaione                    | 40            |
|   |               | Casseruola zucchero                    | 40            |
|   |               | Cassetto buffet                        | 411           |
|   |               | Catenella di sicurezza per cavalletti  | 489           |
|   |               | Cavalletto segnalazione                | 489           |
|   |               | Cavatappi a doppia leva                | 324           |
|   |               | Cavatappi cameriere                    | 324           |
|   |               | Centrifuga manuale per verdura         | 111           |
|   |               | Centrifuga spremisucchi                | 504, 506      |
|   |               | Ceppa                                  | 165           |
|   |               | Ceppo portacoltelli                    | 158, 159      |
|   |               | Cesta baguettes                        | 423           |
|   |               | Cesta per friggere                     | 60            |
|   |               | Cestelli bicchieri                     | 466, 467      |

|                                     |                           |                                      |               |                               |          |
|-------------------------------------|---------------------------|--------------------------------------|---------------|-------------------------------|----------|
| Cestello per posate                 | 467                       | Coltello pompelmo                    | 87, 91        | Copripiatto                   | 104, 431 |
| Cestino impasto                     | 248                       | Coltello prosciutto                  | 137, 143      | Cornetto cinese               | 111, 112 |
| Cesto agrumi                        | 312                       | Coltello salmone                     | 137, 143, 145 | Couscoussiera                 | 30       |
| Cesto con supporto filo             | 426                       | Coltello torta                       | 151           | Crème caramel                 | 205      |
| Cesto frutta                        | 311, 312, 353             | Coltello verdure                     | 84            | Crepiera                      | 498      |
| Cesto gastronorm                    | 473                       | Combi mixer/frusta                   | 503           | Cucchiaini decorazione        | 107, 179 |
| Cesto pane                          | 421>427, 473              | Combinato cutter/tagliaverdure       | 505           | Cucchiaino assenzio           | 305      |
| Cesto pane cotone                   | 427                       | Compressore per penna aerografa      | 192, 515      | Cucchiaino cinesee            | 254      |
| Cesto pane tavola                   | 353, 354                  | Contenitore cilindrico               | 28            | Cucchiaino cocktail           | 92       |
| Cesto uova                          | 427                       | Contenitore di riserva               | 318           | Cucchiaino finger-food        | 405      |
| Chitarra                            | 195                       | Contenitore isotermico               | 475>478       | Cucchiaino miscelatore        | 304      |
| Ciotola doppia parete               | 442                       | Contenitore per alimenti             | 471, 472      | Cucchiaino per spaghetti      | 100      |
| Ciotola melamina                    | 402>404, 407>411, 431>432 | Contenitore per cannucce             | 289           | Cucchiaino riso               | 257      |
| Ciotola refrigerata                 | 431>432                   | Contenitore per cialde               | 289           | Cucchiainone                  | 100      |
| Ciotola testa di leone              | 353                       | Contenitore per impasti              | 271           | Cucchiainone PA+              | 79       |
| Ciotola tortillas                   | 48                        | Contenitore per uova                 | 116           | Cucchiainone salse            | 100      |
| Ciotola vetro                       | 431                       | Contenitore rifiuti                  | 490, 491      | Cucchiainone unipezzo         | 98, 99   |
| Ciotole/vassoi serie argilla        | 345, 346                  | Contenitore salvaspazio              | 473           | Cucina etnica                 | 249>262  |
| Ciotole/vassoi serie nero & marrone | 344, 345                  | Contenitore sovrapponibile           | 473, 475      | Cuoci riso a vapore           | 508      |
| Clip chiudi sacco                   | 112, 188                  | Contenitore universale               | 470           | Cuociasparagi                 | 18       |
| Clip flessibili                     | 367, 427                  | Contenitore versatore                | 317, 318      | Cuocivapore                   | 257, 261 |
| Clip per vasetti Weck               | 349                       | Contenitori GN                       | 51>77         | Cutter da tavolo              | 501, 505 |
| Clip reggibicchieri                 | 326                       | Contenitori GN inox                  | 52>58         | <b>D</b>                      |          |
| Cloche                              | 358                       | Contenitori GN melamina              | 72, 73        | Decoratore                    | 88       |
| Cloche per affumicatore             | 316                       | Contenitori GN PC                    | 61, 62        | Densimetro per salamoia       | 131      |
| Cocotte molluschi                   | 360                       | Contenitori GN porcellana            | 74, 75        | Densimetro per sciroppo       | 131      |
| Colafrutto                          | 27, 100                   | Contenitori GN porcellana induzione  | 76, 77        | Disidratatore                 | 501      |
| Colapasta                           | 108, 109                  | Contenitori GN PP                    | 67>71         | Display per buffet            | 413, 414 |
| Colapasta a settori                 | 28                        | Contenitori GN Tritan                | 63, 64        | Distributore di cereali       | 437>439  |
| Colapasta rinforzato                | 111                       | Coperchi ermetici Weck               | 349           | Distributore di latte         | 438, 439 |
| Colatutto PA+                       | 82                        | Coperchi GN ermetici con GUARNIZIONE | 69            | Distributore di succhi        | 438, 439 |
| Colino                              | 109, 111                  | Coperchio per ceste pane             | 425           | Distributore panini           | 420      |
| Colino cocktail                     | 305                       | Coperchio per ciotole                | 431           | Distributore termico          | 437      |
| Colino Julep                        | 305                       | Coperchio roll-top                   | 425, 428>430  | Dosa creme                    | 192      |
| Collare salvagoccia                 | 365                       | Copertura igienica                   | 422           | Dosacaffè                     | 92       |
| Colonna luminosa                    | 415                       | Copertura protettiva                 | 469           | Dosatore a leva               | 106      |
| Colonna portasecchiello             | 363                       | Copertura termica                    | 479           | Dosatore miele/cremiera       | 277      |
| Coltelleria                         | 136>158                   | Copertura vinile                     | 487           | <b>E</b>                      |          |
| Coltelli forgiati                   | 136>138                   | Coperture monouso                    | 481           | Espositore buffet cromato     | 434, 435 |
| Coltelli sushi giapponesi           | 155, 156                  | Coppa ananas                         | 298           | Espositore buffet legno       | 436      |
| Coltelli tranciati                  | 139>147                   | Coppa burro                          | 352           | Espositore caldo ventilato    | 500      |
| Coltello apriostriche               | 84, 90, 150               | Coppa caviale                        | 362           | Espositore cereali            | 437      |
| Coltello bar                        | 87                        | Coppa gelato                         | 290>292       | Espositore frutta             | 433, 434 |
| Coltello bistecca                   | 138, 145, 146             | Coppa martini/margarita              | 298           | Espositore marmellate         | 437      |
| Coltello castagne                   | 84                        | Coppa punch                          | 416           | Espositore per bocchette      | 189      |
| Coltello formaggio                  | 151                       | Coppa riso                           | 250, 252      | Espositore per cereali        | 437      |
| Coltello ghiaccio                   | 121                       | Coppa soufflè                        | 44, 48        | Espositore per sacchetti      | 189      |
| Coltello grana                      | 84, 89, 150               | Coppa zucca                          | 298           | Espositore per vetrina gelato | 294      |
| Coltello pane                       | 138, 147                  | Coppetta sake                        | 254           |                               |          |
| Coltello per marzapane              | 179                       | Coppette melamina                    | 335           |                               |          |



|                                      |               |                                       |                            |  |            |
|--------------------------------------|---------------|---------------------------------------|----------------------------|--|------------|
| Espositore sacchetti/bocchette       | 189           | GN bacinelle antiaderenti             | 55                         | Levatorboli                            | 88, 91     |
| Etichette allergeni                  | 132, 133      | GN bacinelle forate                   | 56                         | Lira per formaggi                      | 118        |
| Etichette identificazione x cestelli | 467           | GN bacinelle, maniglie fisse          | 53, 54                     | Lira per pan di Spagna                 | 195        |
| <b>F</b>                             |               | GN bacinelle, maniglie interne        | 54                         | <b>M</b>                               |            |
| Falcetta cinese                      | 149           | GN bacinelle, maniglie rientranti     | 55                         | Macchina per cialde                    | 501, 502   |
| Falcetta macellaio                   | 149, 150      | GN coperchi                           | 57                         | Macchina per gelato                    | 500        |
| Falcetta prezzemolo                  | 84            | GN coperchi ermetici                  | 64                         | Macchina per raclette                  | 359, 513   |
| Falso fondo forato                   | 60            | GN coperchio con guarnizione silicone | 62                         | Macina erbe/peperoncino                | 383        |
| Fascia microforata                   | 203           | GN-teglie                             | 58, 59                     | Macina noce moscata                    | 383, 384   |
| Fasciatoio                           | 486           | Grattugia                             | 85, 90, 117, 118, 122, 123 | Macina pepe/sale PEUGEOT               | 374>385    |
| Ferma prosciutto                     | 162           | Grattugia noce moscata                | 123                        | Macinaerbe                             | 124        |
| Fermatovaglia                        | 358           | Grattugia per spatzle                 | 123                        | Mandolino                              | 118, 119   |
| Fingerfood porcellana                | 337, 338      | Grattugia per wasabi                  | 261                        | Manico per mop                         | 488        |
| Flacone dosatore                     | 106, 107      | Grembiule barman                      | 320                        | Manico telescopico                     | 489        |
| Flacone nebulizzatore                | 199           | Grembiule di protezione               | 166                        | Mantecatore per burro                  | 121        |
| Flacone per bagne                    | 199           | Griglia di colaggio                   | 190                        | Marcatore pane Kaiser                  | 248        |
| Flair bottle                         | 315           | Griglia Dim Sum                       | 259                        | Mascherine per cacao                   | 276        |
| Flexipan teglie silicone             | 232>247       | Griglia in filo                       | 60                         | Mestolo                                | 100        |
| Flute champagne                      | 298           | Griglia kebab/gyros                   | 498                        | Mestolo PA+                            | 80, 81     |
| Fontana cioccolato                   | 415, 513      | Griglia per tempura                   | 259                        | Mestolo unipezzo                       | 98, 99     |
| Fontana cocktails                    | 415           | Griglia reversibile                   | 46                         | Mezzaluna                              | 151        |
| Forbice                              | 153, 154      | Griglia a contatto                    | 496                        | Miscelatori cocktail                   | 303, 304   |
| Forbice per erbe                     | 117           | Guanti in lattice                     | 167                        | Misurino cocktail                      | 305        |
| Forbice sigari                       | 370           | Guanti scrub                          | 167                        | Mixer                                  | 503, 504   |
| Forchetta lumache                    | 400           | Guanto anti taglio                    | 167                        | Molla ghiaccio                         | 315, 398   |
| Forchette fonduta                    | 359           | Guanto da forno                       | 166, 167                   | Molla lumache                          | 398        |
| Forchettina ostriche                 | 399           | Guanto in cotta di maglia             | 166                        | Molla PA+                              | 80         |
| Forchettina patate                   | 91            | Guarnizioni Weck                      | 349                        | Molla pane                             | 397        |
| Forchettine aragosta                 | 361           | <b>I</b>                              |                            | Molla per asparagi                     | 398        |
| Forchettine lumache                  | 361           | Imbuto                                | 105                        | Molla spaghetti                        | 397        |
| Forchettine pralineria               | 179           | Imbuto colatore                       | 191                        | Molla zucchero                         | 398        |
| Forchettone                          | 100, 138, 151 | Impastatrice planetaria               | 509                        | Molle e forbici a servire serie Living | 397>400    |
| Forchettone unipezzo                 | 98, 99        | Insaccatrice verticale                | 163                        | Monouso forchettine & cucchiaini       | 326        |
| Formaggiera                          | 357           | Insalatiera                           | 353                        | Mop                                    | 488, 489   |
| Forno microonde                      | 509           | Insalatiera melamina                  | 402                        | Mortaio e pestello                     | 261        |
| Forno multifunzione                  | 499           | <b>K</b>                              |                            | Multi-distributore                     | 435, 436   |
| Friggitrice                          | 499           | Kit di infusione rapida               | 296                        | <b>N</b>                               |            |
| Frullatore                           | 507           | <b>L</b>                              |                            | Nastro per dolci                       | 201        |
| Frullino                             | 508           | Laccetti da cucina                    | 113                        | Nebulizzatore olio/acetato             | 356        |
| Frusta                               | 100, 103      | Lame panettiere usa e getta           | 248                        | Noccioli di cottura                    | 201        |
| Frusta PA+                           | 82            | Lampada ad infrarossi                 | 502                        | <b>O</b>                               |            |
| <b>G</b>                             |               | Lampada per zucchero                  | 193, 514                   | Oliera                                 | 261, 264   |
| Ganci                                | 160, 161      | Lanterne                              | 418                        | Omogeneizzatore                        | 505        |
| Gancio appendi borsa                 | 363           | Lattiera cappuccino                   | 277                        | Orologio da parete                     | 133        |
| Gel combustibile                     | 455           | Lattiera con coperchio                | 277                        | <b>P</b>                               |            |
| Gelateria                            | 285>296       | Lavagna                               | 368                        | Padella balti/karahi                   | 260        |
| Girello                              | 189           | Legatovagliolo                        | 358                        | Padella blini                          | 33, 35, 42 |
| Glacette termica                     | 363, 364      | Levacapsule                           | 86, 91, 325                |  |            |

|  |               |                                  |               |                            |               |
|--|---------------|----------------------------------|---------------|----------------------------|---------------|
| Padella crêpes                             | 32, 33        | Pentolame serie 2500 3-ply       | 23>25         | Porta posate               | 467, 468      |
| Padella Tamagoyaki                         | 260           | Pentolame serie 6100 alluminio   | 29>33         | Porta rotolo               | 104, 481      |
| Padella Tawa                               | 260           | Pentolame serie Gluten Free inox | 21, 518, 519  | Porta snack                | 327, 328      |
| Padella Toban                              | 259           | Percolatore per caffè            | 451, 511      | Portabustine zucchero      | 278           |
| Padelle ferro                              | 34, 35        | Pesa sciropo (densimetro)        | 194           | Portacandela               | 366           |
| Pala ghiaccio                              | 478           | Pesciera                         | 27, 33, 40    | Portaciotole cromato       | 431, 433      |
| Pala per patate fritte                     | 101           | Pestaghiaccio                    | 313           | Portacombustibile          | 455           |
| Pala pizza                                 | 264>267       | Pettini decoratori               | 198           | Portacondimenti            | 319, 357      |
| Pala torta                                 | 96, 189       | Piano caldo                      | 503           | Portagiornale              | 368           |
| Pala torta                                 | 398           | Piastra ad induzione             | 453, 511      | Portaposate                | 357, 430      |
| Paletta forata                             | 100           | Piastre elettriche               | 455           | Portarifiuti da tavola     | 361           |
| Paletta unipezzo                           | 99            | Piattino fingerfood              | 403           | Portaspago                 | 162           |
| Palette PA+                                | 79>81         | Piatto fingerfood                | 415           | Portataglieri              | 166           |
| Pallet                                     | 493           | Piatto lumache                   | 361           | Portatoast                 | 352           |
| Panno in microfibra                        | 489           | Piatto melamina                  | 404, 406, 410 | Portatovaglioli            | 278, 279, 288 |
| Panno passabrodo                           | 112           | Piatto torta/formaggi            | 409           | Portauovo                  | 352           |
| Passapomodoro                              | 124           | Pietanziera                      | 478           | Porzionatore               | 91, 112, 287  |
| Passathé                                   | 352           | Pietra per affilare              | 152           | Posacenera                 | 369, 370      |
| Passaverdura                               | 111, 124      | Pinza                            | 304           | Posacenera a colonna       | 493           |
| Passaverdura elettrico                     | 517           | Pinza a servire                  | 102           | Posate caviale             | 362           |
| Pasticceria                                | 168>248       | Pinza aragosta                   | 361           | Pressa bottiglie e lattine | 125           |
| Pattumiera                                 | 488           | Pinza champagne                  | 365           | Pressa hamburger           | 163           |
| Pattumiera a pedale                        | 492           | Pinza da cucina                  | 102, 103      | Pressapatate               | 90            |
| Pedana                                     | 493           | Pinza per affettati              | 161           | Pressapolipo               | 113           |
| Pela asparagi                              | 86            | Pinza per anatra                 | 262           | Presse-canard              | 113           |
| Pela mele                                  | 115           | Pinza per mop                    | 489           | Pungisalame                | 159           |
| Pela pomodori                              | 87            | Pinza per teglie                 | 267           | Raccoglibriciole           | 358           |
| Pela/svuota ananas                         | 114           | Pinza togli lisce                | 102           | Raschia per pasta          | 271           |
| Pela/taglia avocado                        | 116           | Pirofila ovale melamina          | 405           | <b>R</b>                   |               |
| Pelapatate                                 | 87, 91, 117   | Pirofile forno                   | 50            | Raschietti                 | 198           |
| Pelarence                                  | 87, 91        | Pirofile forno APPOLIA PEUGEOT   | 388>395       | Rastelliera per teglie     | 272           |
| Pelatrice elettrica                        | 115, 501      | Pistola elettrica                | 192, 514      | Rastrelliera               | 103, 321      |
| Penna a gesso liquido                      | 287, 368, 427 | Pizza                            | 263>274       | Rechaud                    | 360           |
| Penna aerografa                            | 192           | Pizzi sottotorta                 | 189           | Retina pizza               | 272           |
| Pennello                                   | 85, 90, 198   | Plancia melamina                 | 408           | Ricambi                    | 524>532       |
| Pennello per wok                           | 262           | Pompa sottovuoto per vino        | 324           | Ricariche panna montata    | 296           |
| Pentola cinese                             | 260           | Pompetta con terminale in rame   | 193           | Ricariche soda             | 313           |
| Pentola per riso dolce                     | 258           | Pompetta per sugo                | 102           | Riga                       | 194           |
| Pentolame                                  | 10>48         | Ponte per sushi/sashimi          | 252           | Rigalimoni                 | 88, 92        |
| Pentolame ghisa smaltata                   | 43>48         | Porta Brezel                     | 422           | Riscalda sake              | 254           |
| Pentolame serie 1000 inox                  | 14>16         | Porta cannuce                    | 278           | Rompighiaccio              | 313           |
| Pentolame serie 1100 inox                  | 10>12         | Porta coni                       | 288>290       | Rotella taglia pasta       | 84, 88, 196   |
| Pentolame serie 12300 3-ply                | 441           | Porta coppette                   | 334           | Rotella taglia pizza       | 84, 88, 267   |
| Pentolame serie 12300 3-ply                | 441           | Porta cucchiaini                 | 277           | Rotolo portacoltelli       | 158           |
| Pentolame serie 15200 rame 3-ply miniature | 38            | Porta menù                       | 367           | Rouet                      | 120           |
| Pentolame serie 15300-15400 rame stagnato  | 39, 40        | Porta oggetti da bar             | 315           | Rullo                      | 197           |
| Pentolame serie 15500 rame 3-ply induzione | 36, 37        | Porta pale                       | 266           | Rullo bucasfoglia          | 196           |
| Pentolame serie 16130 alluminio miniature  | 41            | Porta palette e coppette         | 289           | Runner                     | 341           |
| Pentolame serie 2000 inox                  | 17>19         | Porta piatti in filo             | 467           |                            |               |
| Pentolame serie 2100 inox                  | 13            | Porta piatti rotante             | 477           |                            |               |

|                                      |               |                                     |                    |                                      |               |
|--------------------------------------|---------------|-------------------------------------|--------------------|--------------------------------------|---------------|
| <b>S</b>                             |               |                                     |                    |                                      |               |
| Sacchetto per decorare               | 187, 188      | Sessola                             | 107                | Stampo mooncake                      | 256           |
| Sacco vinile                         | 487           | Sessola per ghiaccio                | 313                | Stampo panzerotti                    | 123           |
| Salamandra                           | 497           | Set fonduta                         | 40, 359            | Stampo per burro                     | 121           |
| Salinometro                          | 131           | Setacci                             | 107, 199           | Stampo per nigiri                    | 257           |
| Salsiera                             | 253, 352      | Sgocciolatore                       | 231                | Stampo scanalato                     | 40            |
| Samovar                              | 450, 451, 512 | Shaker                              | 306, 307           | Stampo uovo                          | 224           |
| Saponetta togli odori                | 92            | Sifone nitro                        | 276                | Stand per vassoi                     | 418           |
| Sbuccia melone                       | 87            | Sifone panna                        | 295                | Stencils                             | 216           |
| Scalda würstel                       | 498           | Sifone soda                         | 313                | Stendipasta                          | 194           |
| Scaldacaffè                          | 450           | Siringa per marinata                | 102                | Sterilizzatore coltelli              | 159, 517      |
| Scaldacognac                         | 365           | Siringa per pasticceria             | 188                | Stiletto aragosta                    | 361           |
| Scaldapiatti                         | 500           | Sistema di pulizia, kit Pulse       | 488                | Stiletto tailandese                  | 120           |
| Scaldavivande                        | 444>449       | Snocciolatore                       | 118                | Stoccaggio, trasporto, pulizia       | 466>494       |
| Scaletta pieghevole                  | 493           | Sottopentola                        | 44, 360            | Strisce reattive per oli di frittura | 131           |
| Scalpellino ghiaccio                 | 121           | Spaccaghiaccio elettrico            | 507                | Stuoietta                            | 257           |
| Scatola bento                        | 252           | Spalmaburro                         | 85, 90             | Stuzzicadenti                        | 326           |
| Scatola buffet acacia                | 420, 421      | Spargi cacao                        | 277                | Supporto bacchette cinesi            | 255           |
| Scatola portabustine thè             | 278           | Spargi formaggio                    | 357                | Supporto bottiglie                   | 321, 322      |
| Scavino                              | 86, 91        | Spargisale/pepe                     | 355                | Supporto buffet in filo              | 426, 427      |
| Schiaccianoci                        | 361           | Spargizucchero                      | 199, 277           | Supporto casseruolina                | 44            |
| Schiacciapatate                      | 117           | Spatola crêpe                       | 101                | Supporto con pietra ollare           | 359           |
| Schiumarola                          | 100, 101      | Spatola gelato                      | 286                | Supporto cromato                     | 402, 432      |
| Schiumarola fritto                   | 262           | Spatola in resina alimentare        | 103                | Supporto murale porta pellicola      | 104           |
| Schiumarola PA+                      | 80, 81        | Spatole                             | 95, 96             | Supporto numero tavola               | 367           |
| Schiumarola unipezzo                 | 99, 100       | Spatole PA+                         | 79                 | Supporto per temaki                  | 252           |
| Schiumarola Wonton                   | 262           | Spazzola grill                      | 103                | Supporto secchio vino tavola         | 363           |
| Sciabola per Sommelier               | 365           | Spazzola orientabile                | 265                | Supporto targhetta                   | 367           |
| Scolapiatti a muro                   | 469           | Spazzola pane                       | 248                | Supporto vasetti Weck                | 349           |
| Scopa a forcice                      | 488           | Spazzola per farina                 | 199                | Supporto vassoio frutti di mare      | 362           |
| Scopa c/alza immondizia              | 488           | Spazzole lavabicchieri              | 321                | Svuota ananas                        | 86            |
| Scopa spingiacqua                    | 488           | Specchi                             | 417                | Svuota carciofi                      | 116           |
| Secchio con strizzatore              | 490           | Spelucchino                         | 89, 138, 146       | Svuota zucchine                      | 86, 91        |
| Secchio ghiaccio                     | 315, 478      | Spiedini                            | 160, 256, 325, 326 |                                      |               |
| Secchio graduato                     | 109, 490      | Spillone portascontrini             | 103                | <b>T</b>                             |               |
| Secchio portabottiglie               | 414           | Spremiaglio                         | 90, 118            | Taglia ananas                        | 115           |
| Secchio vino                         | 363           | Spremiagrumi elettrico              | 506>508            | Taglia capsula                       | 324           |
| Sega per ossa                        | 162           | Spremiagrumi manuale                | 312                | Taglia cavolini di Bruxelles         | 116           |
| Segatura aromatizzata                | 316           | Spremilimone                        | 312                | Taglia croissants                    | 196           |
| Seggiolone                           | 486           | Squamapesce                         | 84, 85, 88, 262    | Taglia cubi                          | 114           |
| Segnagusto                           | 287, 288      | Stampi bigné                        | 245, 246           | Taglia funghi                        | 116           |
| Segnalatore telescopico di sicurezza | 490           | Stampi ghiaccio                     | 314                | Taglia pane                          | 421           |
| Segnaporzioni                        | 197           | Stampi in policarbonato per praline | 217>223            | Taglia patate                        | 117           |
| Senapiera                            | 352           | Stampi in silicone per praline      | 216                | Taglia ricci di mare                 | 361           |
| Separatore                           | 60            | Stampi Natale policarbonato         | 225                | Taglia tortillas                     | 117           |
| Separauova                           | 92            | Stampi Pasqua policarbonato         | 225                | Taglia uova                          | 115           |
| Servitartufi                         | 355           | Stampi per pane                     | 246, 247           | Taglia verdure                       | 114, 119, 120 |
| Servizio caffè                       | 280           | Stampi silicone                     | 226>231            | Tagliapasta                          | 271           |
| Servizio olera                       | 356, 357      | Stampi tavolette cioccolato         | 223                | Tagliapasta con espulsore            | 178, 179      |
|                                      |               | Stampo cucchiaino                   | 223                | Tagliapasta estensibile              | 196           |
|                                      |               | Stampo gelato                       | 293, 294           | Tagliapasta inox                     | 169>177       |

|                                  |                        |                                       |                    |
|----------------------------------|------------------------|---------------------------------------|--------------------|
| Tagliapasta PA+                  | 178                    | Tritaghiaccio elettrico               | 508                |
| Tagliasigari da tavola           | 369                    | Tritaghiaccio manuale                 | 313                |
| Tagliatartufi                    | 355                    | Tronchetto tagliapizza                | 267                |
| Tagliaverdure elettrico          | 504                    | <b>U</b>                              |                    |
| Tagliere HDPE                    | 164, 165               | Utensili cucina PA+                   | 79>82              |
| Tagliere melamina                | 408                    | Utensili da cucina                    | 78>135             |
| Tagliere pane                    | 166, 411, 421, 429>430 | <b>V</b>                              |                    |
| Tagliere sushi                   | 252                    | Valigetta cameriere                   | 325                |
| Taglieri da portata              | 330>334                | Valigia Barman                        | 320                |
| Tampone finto legno              | 214                    | Valigia cuoco                         | 157                |
| Tappeto silicene                 | 200, 201               | Vaporiera                             | 509                |
| Tappeto sottobicchieri           | 319                    | Vasca riso hangiri                    | 258                |
| Tappo dosatore                   | 323                    | Vasetti Weck                          | 347, 348, 349      |
| Tappo dosatore automatico        | 322                    | Vaso fiori                            | 365                |
| Tappo spumante                   | 323                    | Vaso porta sacchetto                  | 189                |
| Tappo versatore                  | 317, 322               | Vaso soia                             | 254                |
| Tappo vino                       | 323                    | Vassoi & ciotole melamina serie Thara | 250, 251           |
| Targhetta tavola                 | 367                    | Vassoi inox                           | 418, 419           |
| Tartellette                      | 211, 212               | Vassoi melamina                       | 403, 404, 407, 410 |
| Tastevin                         | 365                    | Vassoio carni                         | 162                |
| Tavola                           | 339>370                | Vassoio colazione con gambe           | 461                |
| Tavolino con box termico         | 480, 503               | Vassoio con campana                   | 355                |
| Tavolino room service            | 463, 464               | Vassoio conto                         | 279                |
| Tazza julep                      | 300, 301               | Vassoio espositore                    | 199, 200           |
| Tazza moscow mule                | 298>300                | Vassoio fast food                     | 480, 481           |
| Tegame                           | 27                     | Vassoio frutti di mare                | 362                |
| Tegamino uova                    | 50                     | Vassoio portatovagliolo               | 252                |
| Teglia forno                     | 272>274                | Vassoio room service                  | 461                |
| Teglia pizza                     | 272, 273               | Versatore                             | 365                |
| Teglie                           | 190, 191               | Versavino                             | 364                |
| Teglie GN alluminio/antiaderenti | 58                     | Vetrina da banco                      | 283, 284           |
| Teiera                           | 254, 255               | Vetrina refrigerata                   | 429, 430           |
| Telai per dolci                  | 204, 205               | Vetrina riscaldata                    | 500                |
| Telaio per ganache               | 195                    | Vetrina set buffet                    | 428, 429           |
| Telaio pieghevole                | 486                    | Vetrina sigari                        | 370                |
| Temperatrice                     | 193, 294, 295, 514     | <b>W</b>                              |                    |
| Temperino per verdure            | 85                     | Wok                                   | 24, 35, 258, 259   |
| Termoigrometro                   | 131                    | <b>Z</b>                              |                    |
| Termometri                       | 126>132                | Zuppiera elettrica                    | 452, 513           |
| Termoregolatore                  | 455                    |                                       |                    |
| Tester per oli di frittura       | 132                    |                                       |                    |
| Tiki mug                         | 301, 302               |                                       |                    |
| Timer digitale                   | 131                    |                                       |                    |
| Tortiere alluminio               | 206                    |                                       |                    |
| Tortiere antiaderenti            | 209>211, 213, 214      |                                       |                    |
| Tostapane                        | 496                    |                                       |                    |
| Tovaglietta                      | 341                    |                                       |                    |
| Trancia spicchi                  | 114, 115               |                                       |                    |
| Trinciapollo                     | 152                    |                                       |                    |
| Tritacarne elettrico             | 515                    |                                       |                    |



**NUMERICAL INDEX**

INDICE NUMERICO

NUMERISCH INDEX

INDEX NUMERIQUE

INDICE NUMERICO

**NUMERICAL INDEX INDICE NUMERICO NUMERISCH INDEX INDEX NUMERIQUE INDICE NUMERICO**

| Cod.     | pag. | Cod.     | pag. | Cod.     | pag. | Cod.     | pag. | Cod.     | pag. | Cod.     | pag. | Cod.     | pag. |
|----------|------|----------|------|----------|------|----------|------|----------|------|----------|------|----------|------|
| 11001-16 | 15   | 11009-36 | 15   | 11101-32 | 11   | 11109-40 | 11   | 11161-32 | 12   | 11714-45 | 35   | 11742-18 | 273  |
| 11001-18 | 15   | 11009-40 | 15   | 11101-36 | 11   | 11109-45 | 11   | 11161-36 | 12   | 11714-50 | 35   | 11742-20 | 273  |
| 11001-20 | 15   | 11009-45 | 15   | 11101-40 | 11   | 11109-50 | 11   | 11161-40 | 12   | 11715-12 | 35   | 11742-22 | 273  |
| 11001-22 | 15   | 11009-50 | 15   | 11101-45 | 11   | 11112-16 | 12   | 11161-45 | 12   | 11716-16 | 35   | 11742-24 | 273  |
| 11001-24 | 15   | 11009-60 | 15   | 11101-50 | 11   | 11112-18 | 12   | 11161-50 | 12   | 11716-20 | 35   | 11742-26 | 273  |
| 11001-28 | 15   | 11010-16 | 15   | 11102-28 | 11   | 11112-20 | 12   | 11161-60 | 12   | 11716-22 | 35   | 11742-28 | 273  |
| 11001-32 | 15   | 11010-18 | 15   | 11102-32 | 11   | 11112-24 | 12   | 11161F16 | 21   | 11716-24 | 35   | 11742-30 | 273  |
| 11001-36 | 15   | 11010-20 | 15   | 11102-36 | 11   | 11113-18 | 12   | 11161F20 | 21   | 11716-26 | 35   | 11742-32 | 273  |
| 11001-40 | 15   | 11010-24 | 15   | 11102-40 | 11   | 11113-20 | 12   | 11161F24 | 21   | 11716-28 | 35   | 11742-36 | 273  |
| 11001-45 | 15   | 11011-16 | 16   | 11102-45 | 11   | 11113-24 | 12   | 11161F28 | 21   | 11716-32 | 35   | 11742-40 | 273  |
| 11001-50 | 15   | 11011-18 | 16   | 11102-50 | 11   | 11113-26 | 12   | 11617-20 | 32   | 11716-36 | 35   | 11742-45 | 273  |
| 11001-60 | 15   | 11011-20 | 16   | 11102-99 | 524  | 11114-20 | 12   | 11617-24 | 32   | 11716-40 | 35   | 11742-50 | 273  |
| 11006-12 | 16   | 11011-24 | 16   | 11105-16 | 11   | 11114-24 | 12   | 11617-28 | 32   | 11716-45 | 35   | 11742-60 | 273  |
| 11006-14 | 16   | 11012-16 | 15   | 11105-20 | 11   | 11114-28 | 12   | 11617-32 | 32   | 11717-34 | 35   | 11744-20 | 272  |
| 11006-16 | 16   | 11012-18 | 15   | 11105-24 | 11   | 11114-32 | 12   | 11701-02 | 264  | 11717-37 | 35   | 11744-24 | 272  |
| 11006-18 | 16   | 11012-20 | 15   | 11105-28 | 11   | 11114-36 | 12   | 11701-06 | 264  | 11717-42 | 35   | 11744-28 | 272  |
| 11006-20 | 16   | 11012-24 | 15   | 11105-32 | 11   | 11114-40 | 12   | 11701-10 | 264  | 11717-47 | 35   | 11744-32 | 272  |
| 11006-22 | 16   | 11013-18 | 15   | 11105-36 | 11   | 11114-45 | 12   | 11701-13 | 264  | 11718-20 | 35   | 11750-11 | 60   |
| 11006-24 | 16   | 11013-20 | 15   | 11105-40 | 11   | 11115-20 | 12   | 11701-16 | 264  | 11718-22 | 35   | 11760-11 | 60   |
| 11006-28 | 16   | 11013-24 | 15   | 11106-14 | 11   | 11115-24 | 12   | 11702-02 | 264  | 11718-24 | 35   | 11910-12 | 28   |
| 11006-32 | 16   | 11013-26 | 15   | 11106-16 | 11   | 11115-28 | 12   | 11702-06 | 264  | 11721-28 | 35   | 11910-14 | 28   |
| 11006-36 | 16   | 11014-20 | 16   | 11106-20 | 11   | 11115-32 | 12   | 11702-10 | 264  | 11739-20 | 272  | 11910-16 | 28   |
| 11007-16 | 15   | 11014-24 | 16   | 11106-24 | 11   | 11115-36 | 12   | 11702-16 | 264  | 11739-24 | 272  | 11910-18 | 28   |
| 11007-18 | 15   | 11014-28 | 16   | 11106-28 | 11   | 11115-40 | 12   | 11704-02 | 264  | 11739-28 | 272  | 11910-20 | 28   |
| 11007-20 | 15   | 11014-32 | 16   | 11106-32 | 11   | 11115-45 | 12   | 11704-06 | 264  | 11739-32 | 272  | 11911-12 | 28   |
| 11007-22 | 15   | 11014-36 | 16   | 11106-36 | 11   | 11115-50 | 12   | 11704-13 | 264  | 11739F20 | 518  | 11911-14 | 28   |
| 11007-24 | 15   | 11014-40 | 16   | 11107-16 | 11   | 11117-20 | 12   | 11704-16 | 264  | 11739F24 | 518  | 11911-16 | 28   |
| 11007-28 | 15   | 11014F20 | 21   | 11107-20 | 11   | 11117-24 | 12   | 11705-02 | 264  | 11739F28 | 518  | 11911-18 | 28   |
| 11007-32 | 15   | 11014F24 | 21   | 11107-24 | 11   | 11117-28 | 12   | 11705-06 | 264  | 11739F32 | 518  | 11911-20 | 28   |
| 11007-36 | 15   | 11014F28 | 21   | 11107-28 | 11   | 11117-32 | 12   | 11705-10 | 264  | 11740-14 | 273  | 11913-16 | 28   |
| 11007-40 | 15   | 11014F32 | 21   | 11107-32 | 11   | 11117-36 | 12   | 11705-14 | 264  | 11740-16 | 273  | 11913-20 | 28   |
| 11007-45 | 15   | 11061-12 | 16   | 11107-36 | 11   | 11117-40 | 12   | 11706-02 | 264  | 11740-18 | 273  | 11913-24 | 28   |
| 11007-50 | 15   | 11061-16 | 16   | 11107-40 | 11   | 11119-20 | 11   | 11706-06 | 264  | 11740-20 | 273  | 11913-28 | 28   |
| 11007-60 | 15   | 11061-18 | 16   | 11107-45 | 11   | 11119-24 | 11   | 11706-10 | 264  | 11740-22 | 273  | 11922-36 | 28   |
| 11008-16 | 16   | 11061-20 | 16   | 11107-50 | 11   | 11119-28 | 11   | 11706-14 | 264  | 11740-24 | 273  | 11922-40 | 28   |
| 11008-18 | 16   | 11061-22 | 16   | 11108-16 | 12   | 11119-32 | 11   | 11710-AA | 35   | 11740-26 | 273  | 11924-18 | 109  |
| 11008-20 | 16   | 11061-24 | 16   | 11108-20 | 12   | 11123-20 | 11   | 11710-AB | 35   | 11740-28 | 273  | 11924-20 | 109  |
| 11008-24 | 16   | 11061-28 | 16   | 11108-24 | 12   | 11123-24 | 11   | 11713-32 | 35   | 11740-30 | 273  | 11924-22 | 109  |
| 11008-28 | 16   | 11061-32 | 16   | 11108-28 | 12   | 11123-28 | 11   | 11713-40 | 35   | 11740-32 | 273  | 11924-24 | 109  |
| 11008-32 | 16   | 11061-36 | 16   | 11108-32 | 12   | 11161-12 | 12   | 11714-20 | 35   | 11740-36 | 273  | 11924-28 | 109  |
| 11008-36 | 16   | 11061-40 | 16   | 11108-36 | 12   | 11161-14 | 12   | 11714-22 | 35   | 11740-40 | 273  | 11924F20 | 21   |
| 11009-16 | 15   | 11061-45 | 16   | 11109-16 | 11   | 11161-16 | 12   | 11714-24 | 35   | 11741-20 | 272  | 11926-22 | 109  |
| 11009-18 | 15   | 11061-50 | 16   | 11109-20 | 11   | 11161-18 | 12   | 11714-26 | 35   | 11741-24 | 272  | 11926-26 | 109  |
| 11009-20 | 15   | 11101-16 | 11   | 11109-24 | 11   | 11161-20 | 12   | 11714-28 | 35   | 11741-26 | 272  | 11927-24 | 108  |
| 11009-24 | 15   | 11101-20 | 11   | 11109-28 | 11   | 11161-22 | 12   | 11714-32 | 35   | 11741-28 | 272  | 11927-28 | 108  |
| 11009-28 | 15   | 11101-24 | 11   | 11109-32 | 11   | 11161-24 | 12   | 11714-36 | 35   | 11741-32 | 272  | 11927-32 | 108  |
| 11009-32 | 15   | 11101-28 | 11   | 11109-36 | 11   | 11161-28 | 12   | 11714-40 | 35   | 11742-16 | 273  | 11927-36 | 108  |

| Cod.     | pag. | Cod.     | pag. | Cod.     | pag. | Cod.     | pag. | Cod.     | pag. | Cod.     | pag. | Cod.     | pag. |
|----------|------|----------|------|----------|------|----------|------|----------|------|----------|------|----------|------|
| 11927-40 | 108  | 11952-40 | 110  | 11970-10 | 98   | 12001-28 | 18   | 12107-20 | 13   | 12303W24 | 441  | 12550-09 | 400  |
| 11927-45 | 108  | 11953-16 | 110  | 11970-11 | 98   | 12001-32 | 18   | 12107-24 | 13   | 12303Y16 | 441  | 12550-11 | 398  |
| 11927-50 | 108  | 11953-22 | 110  | 11970-12 | 98   | 12001-36 | 18   | 12107-28 | 13   | 12303Y20 | 441  | 12550-12 | 398  |
| 11928-32 | 108  | 11954-26 | 110  | 11970-14 | 98   | 12001-40 | 18   | 12107-32 | 13   | 12303Y24 | 441  | 12550-13 | 398  |
| 11928-36 | 108  | 11954-30 | 110  | 11970-16 | 98   | 12001-45 | 18   | 12107-36 | 13   | 12304B26 | 441  | 12550-14 | 398  |
| 11928-40 | 108  | 11954-32 | 110  | 11970F06 | 519  | 12001-50 | 18   | 12107-40 | 13   | 12304G26 | 441  | 12550-15 | 399  |
| 11929-20 | 112  | 11954-36 | 110  | 11970F08 | 519  | 12001-60 | 18   | 12107-45 | 13   | 12304O26 | 441  | 12550-16 | 399  |
| 11929-24 | 112  | 11954-37 | 110  | 11970F10 | 519  | 12001F20 | 21   | 12107-50 | 13   | 12304W26 | 441  | 12550-17 | 399  |
| 11930-24 | 108  | 11954-40 | 110  | 11971-01 | 100  | 12001F24 | 21   | 12109-16 | 13   | 12304Y26 | 441  | 12550-19 | 400  |
| 11930-28 | 108  | 11955-32 | 108  | 11971-08 | 99   | 12001F28 | 21   | 12109-20 | 13   | 12504-20 | 103  | 12550-20 | 399  |
| 11930-32 | 108  | 11955-36 | 108  | 11971-10 | 99   | 12007-16 | 18   | 12109-24 | 13   | 12507-24 | 24   | 12550-21 | 399  |
| 11930-36 | 108  | 11955-40 | 108  | 11971-12 | 99   | 12007-18 | 18   | 12109-28 | 13   | 12507-28 | 24   | 12550-22 | 398  |
| 11930-40 | 108  | 11955-45 | 108  | 11971-14 | 99   | 12007-20 | 18   | 12109-32 | 13   | 12508-24 | 24   | 12550-25 | 399  |
| 11930-45 | 108  | 11955-50 | 108  | 11971-16 | 99   | 12007-22 | 18   | 12109-36 | 13   | 12509-12 | 25   | 12550-26 | 399  |
| 11930-50 | 108  | 11956-37 | 416  | 11971-18 | 99   | 12007-24 | 18   | 12109-40 | 13   | 12509-20 | 24   | 12550-30 | 399  |
| 11930F24 | 21   | 11956-42 | 416  | 11971-20 | 99   | 12007-28 | 18   | 12109-45 | 13   | 12509-24 | 24   | 12550-33 | 399  |
| 11932-20 | 112  | 11957-20 | 108  | 11971-25 | 99   | 12007-32 | 18   | 12109-50 | 13   | 12509-28 | 24   | 12550-34 | 398  |
| 11932-24 | 112  | 11957-25 | 108  | 11971F10 | 519  | 12007-36 | 18   | 12119-20 | 18   | 12511-10 | 25   | 12550-36 | 399  |
| 11941-35 | 27   | 11957-30 | 108  | 11971F12 | 519  | 12007-40 | 18   | 12119-24 | 18   | 12511-12 | 25   | 12550-43 | 399  |
| 11941-40 | 27   | 11957-35 | 108  | 11972-10 | 99   | 12007-45 | 18   | 12119-28 | 18   | 12511-14 | 25   | 12550-50 | 397  |
| 11941-45 | 27   | 11957-40 | 108  | 11972-12 | 99   | 12007-50 | 18   | 12119-32 | 18   | 12511-16 | 24   | 12550-53 | 398  |
| 11941-50 | 27   | 11965-50 | 27   | 11973-01 | 99   | 12007-60 | 18   | 12123F20 | 21   | 12511-18 | 24   | 12550-54 | 398  |
| 11941-60 | 27   | 11965-60 | 27   | 11973-10 | 99   | 12007F16 | 21   | 12123F24 | 21   | 12511-20 | 24   | 12550-55 | 398  |
| 11943-40 | 27   | 11965-61 | 27   | 11973-12 | 99   | 12007F24 | 21   | 12123F28 | 21   | 12511-24 | 24   | 12550-56 | 398  |
| 11943-45 | 27   | 11966-50 | 524  | 11973F10 | 519  | 12007F28 | 21   | 12300-18 | 442  | 12513-16 | 24   | 12550-58 | 397  |
| 11943-50 | 27   | 11966-60 | 524  | 11973F12 | 519  | 12009-16 | 18   | 12300-24 | 442  | 12513-18 | 24   | 12550-60 | 398  |
| 11943-60 | 27   | 11966-61 | 524  | 11974-50 | 98   | 12009-18 | 18   | 12300B18 | 442  | 12513-20 | 24   | 12550-62 | 397  |
| 11943-61 | 27   | 11967-06 | 98   | 11974-70 | 98   | 12009-20 | 18   | 12300B24 | 442  | 12513-24 | 24   | 12550-63 | 397  |
| 11944-40 | 27   | 11967-08 | 98   | 11975-01 | 99   | 12009-24 | 18   | 12300G18 | 442  | 12514-20 | 25   | 12550-64 | 397  |
| 11944-45 | 27   | 11967-09 | 98   | 11975-50 | 99   | 12009-28 | 18   | 12300G24 | 442  | 12514-24 | 24   | 12550-66 | 398  |
| 11944-50 | 27   | 11967-10 | 98   | 11975-99 | 99   | 12009-32 | 18   | 12300O18 | 442  | 12514-26 | 24   | 12550-68 | 397  |
| 11944-60 | 27   | 11967-12 | 98   | 11976-50 | 99   | 12009-36 | 18   | 12300O24 | 442  | 12514-28 | 24   | 12550-69 | 397  |
| 11944-61 | 27   | 11967-14 | 98   | 11976-99 | 99   | 12009-40 | 18   | 12300W18 | 442  | 12514-32 | 24   | 12550-70 | 397  |
| 11948-40 | 27   | 11967-16 | 98   | 11982-01 | 99   | 12009-45 | 18   | 12300W24 | 442  | 12514-36 | 24   | 12550-73 | 397  |
| 11948-45 | 27   | 11967-18 | 98   | 11982-38 | 98   | 12009-50 | 18   | 12300Y18 | 442  | 12517-24 | 24   | 12550-74 | 397  |
| 11948-50 | 27   | 11967-20 | 98   | 11982F38 | 519  | 12009-60 | 18   | 12300Y24 | 442  | 12517-26 | 24   | 12550-77 | 397  |
| 11948-60 | 27   | 11967-24 | 98   | 11983-37 | 98   | 12037-16 | 18   | 12303B16 | 441  | 12517-28 | 24   | 12550-78 | 397  |
| 11948-61 | 27   | 11968-18 | 98   | 11983-38 | 98   | 12101-16 | 13   | 12303B20 | 441  | 12517-32 | 24   | 12550-80 | 397  |
| 11951-22 | 110  | 11968-20 | 98   | 11984-38 | 98   | 12101-20 | 13   | 12303B24 | 441  | 12517-36 | 24   | 12550-81 | 397  |
| 11951-26 | 110  | 11968-24 | 98   | 11985-34 | 99   | 12101-24 | 13   | 12303G16 | 441  | 12529-32 | 24   | 12550-83 | 397  |
| 11951-32 | 110  | 11969-02 | 99   | 11990-16 | 100  | 12101-28 | 13   | 12303G20 | 441  | 12550-01 | 399  | 12550-84 | 397  |
| 11951-36 | 110  | 11969-06 | 98   | 11991-16 | 100  | 12101-32 | 13   | 12303G24 | 441  | 12550-02 | 398  | 12550-85 | 397  |
| 11951-40 | 110  | 11969-37 | 98   | 12001-16 | 18   | 12101-36 | 13   | 12303O16 | 441  | 12550-03 | 400  | 12550-87 | 397  |
| 11952-22 | 110  | 11970-01 | 99   | 12001-18 | 18   | 12101-40 | 13   | 12303O20 | 441  | 12550-04 | 313  | 12550-88 | 397  |
| 11952-26 | 110  | 11970-06 | 98   | 12001-20 | 18   | 12101-45 | 13   | 12303O24 | 441  | 12550-05 | 400  | 12550-89 | 397  |
| 11952-32 | 110  | 11970-08 | 98   | 12001-22 | 18   | 12101-50 | 13   | 12303W16 | 441  | 12550-06 | 400  | 12561-12 | 25   |
| 11952-36 | 110  | 11970-09 | 98   | 12001-24 | 18   | 12107-16 | 13   | 12303W20 | 441  | 12550-07 | 400  | 12561-16 | 25   |

**NUMERICAL INDEX INDICE NUMERICO NUMERISCH INDEX INDEX NUMERIQUE INDICE NUMERICO**

| Cod.     | pag. | Cod.     | pag. | Cod.     | pag. | Cod.     | pag. | Cod.     | pag. | Cod.     | pag. | Cod.     | pag. |
|----------|------|----------|------|----------|------|----------|------|----------|------|----------|------|----------|------|
| 12561-18 | 25   | 12633-16 | 111  | 12917-25 | 79   | 12940-20 | 107  | 14007-00 | 467  | 14105-20 | 53   | 14119-10 | 54   |
| 12561-20 | 25   | 12633-18 | 111  | 12920-01 | 80   | 12940-25 | 107  | 14008-00 | 467  | 14105F02 | 520  | 14119-15 | 54   |
| 12561-24 | 25   | 12633-20 | 111  | 12920-05 | 80   | 12941-07 | 82   | 14010-00 | 467  | 14105F04 | 520  | 14142-10 | 54   |
| 12561-26 | 25   | 12633-23 | 111  | 12920-10 | 80   | 12941-10 | 82   | 14011-00 | 467  | 14105F06 | 520  | 14142-15 | 54   |
| 12561-28 | 25   | 12633-26 | 111  | 12920-11 | 80   | 12941-12 | 82   | 14013-00 | 467  | 14105F10 | 520  | 14142-20 | 54   |
| 12580-11 | 108  | 12635-23 | 111  | 12920-15 | 80   | 12941-14 | 82   | 14015-08 | 467  | 14105F15 | 520  | 14145-10 | 54   |
| 12580-17 | 108  | 12635-26 | 111  | 12920-16 | 80   | 12941-16 | 82   | 14101-02 | 52   | 14105F20 | 520  | 14145-15 | 54   |
| 12580-21 | 108  | 12635-30 | 111  | 12921-01 | 79   | 12941-18 | 82   | 14101-04 | 52   | 14107-06 | 53   | 14145-20 | 54   |
| 12580-24 | 108  | 12635-35 | 111  | 12921-05 | 79   | 12941-20 | 82   | 14101-06 | 52   | 14107-10 | 53   | 14147-10 | 54   |
| 12580-29 | 108  | 12636-32 | 111  | 12921-10 | 79   | 12941-23 | 82   | 14101-10 | 52   | 14107-15 | 53   | 14147-15 | 54   |
| 12580-30 | 108  | 12638-20 | 111  | 12921-15 | 80   | 12941-26 | 82   | 14101-15 | 52   | 14107-20 | 53   | 14147-20 | 54   |
| 12580-31 | 108  | 12640-14 | 101  | 12926-35 | 82   | 12943-13 | 112  | 14101-20 | 52   | 14107F06 | 520  | 14148-10 | 54   |
| 12580-36 | 108  | 12640-16 | 101  | 12927-35 | 82   | 12944-13 | 112  | 14102-02 | 52   | 14107F10 | 520  | 14148-15 | 54   |
| 12580-40 | 108  | 12640-18 | 101  | 12927-45 | 82   | 12947-13 | 178  | 14102-04 | 52   | 14107F15 | 520  | 14148-20 | 54   |
| 12580-45 | 108  | 12640-20 | 101  | 12928-25 | 82   | 12950-32 | 82   | 14102-06 | 52   | 14107F20 | 520  | 14151-10 | 55   |
| 12580-50 | 108  | 12640-24 | 101  | 12928-30 | 82   | 12950-40 | 82   | 14102-10 | 52   | 14108-06 | 53   | 14151-15 | 55   |
| 12582-13 | 108  | 12640-28 | 101  | 12928-35 | 82   | 12967-06 | 81   | 14102-15 | 52   | 14108-10 | 53   | 14151-20 | 55   |
| 12582-17 | 108  | 12641-14 | 101  | 12928-40 | 82   | 12967-10 | 81   | 14102-20 | 52   | 14108-15 | 53   | 14152-06 | 55   |
| 12582-22 | 108  | 12641-16 | 101  | 12928-45 | 82   | 12968-10 | 81   | 14102F02 | 520  | 14108-20 | 53   | 14152-10 | 55   |
| 12582-24 | 108  | 12641-18 | 101  | 12928-50 | 82   | 12969-06 | 81   | 14102F04 | 520  | 14108F06 | 520  | 14152-15 | 55   |
| 12582-32 | 108  | 12641-20 | 101  | 12928-55 | 82   | 12969-10 | 81   | 14102F06 | 520  | 14108F10 | 520  | 14152-20 | 55   |
| 12582-34 | 108  | 12641-24 | 101  | 12928-60 | 82   | 12970-06 | 81   | 14102F10 | 520  | 14108F15 | 520  | 14155-10 | 55   |
| 12582-38 | 108  | 12641-28 | 101  | 12928F30 | 519  | 12970-08 | 81   | 14102F15 | 520  | 14108F20 | 520  | 14155-15 | 55   |
| 12582-40 | 108  | 12642-28 | 101  | 12928F35 | 519  | 12970-10 | 81   | 14102F20 | 520  | 14109-06 | 53   | 14155-20 | 55   |
| 12604-22 | 107  | 12903-30 | 79   | 12929-25 | 82   | 12970-12 | 81   | 14103-02 | 53   | 14109-10 | 53   | 14157-10 | 55   |
| 12604-30 | 107  | 12903-40 | 79   | 12929-30 | 82   | 12971-10 | 81   | 14103-04 | 53   | 14109-15 | 53   | 14157-15 | 55   |
| 12604-34 | 107  | 12903-45 | 79   | 12929-35 | 82   | 12971-12 | 81   | 14103-06 | 53   | 14109-20 | 53   | 14157-20 | 55   |
| 12604-40 | 107  | 12905-25 | 79   | 12929-40 | 82   | 12972-10 | 81   | 14103-10 | 53   | 14109F06 | 520  | 14158-10 | 55   |
| 12605-22 | 107  | 12905-30 | 79   | 12929-45 | 82   | 12972-12 | 81   | 14103-15 | 53   | 14109F10 | 520  | 14158-15 | 55   |
| 12605-30 | 107  | 12905-35 | 79   | 12929F30 | 520  | 12973-10 | 81   | 14103-20 | 53   | 14109F15 | 520  | 14158-20 | 55   |
| 12605-34 | 107  | 12905-40 | 79   | 12929F35 | 520  | 12973-12 | 81   | 14103F02 | 520  | 14109F20 | 520  | 14159-10 | 55   |
| 12605-40 | 107  | 12905-45 | 79   | 12930-51 | 80   | 12986-01 | 81   | 14103F04 | 520  | 14110-06 | 53   | 14159-15 | 55   |
| 12606-30 | 107  | 12905-50 | 79   | 12930-52 | 80   | 12986-38 | 81   | 14103F06 | 520  | 14110-10 | 53   | 14159-20 | 55   |
| 12606-34 | 107  | 12906-35 | 79   | 12930-62 | 80   | 12992-36 | 28   | 14103F10 | 520  | 14110F06 | 520  | 14162-02 | 55   |
| 12607-22 | 107  | 12907-07 | 79   | 12930-63 | 80   | 12992-40 | 28   | 14103F15 | 520  | 14110F10 | 520  | 14162-04 | 55   |
| 12607-30 | 107  | 12907-08 | 79   | 12930-68 | 80   | 14001-09 | 466  | 14103F20 | 520  | 14112-10 | 53   | 14162-06 | 55   |
| 12607-34 | 107  | 12908-30 | 79   | 12930-69 | 80   | 14001-16 | 466  | 14104-06 | 53   | 14112-15 | 53   | 14165-02 | 55   |
| 12622-07 | 111  | 12908-35 | 79   | 12930-74 | 80   | 14001-25 | 466  | 14104-10 | 53   | 14112-20 | 53   | 14165-04 | 55   |
| 12622-10 | 111  | 12908-40 | 79   | 12930-77 | 80   | 14001-36 | 466  | 14104-15 | 53   | 14115-10 | 54   | 14165-06 | 55   |
| 12622-12 | 111  | 12909-12 | 79   | 12930-78 | 80   | 14001-49 | 466  | 14104F06 | 520  | 14115-15 | 54   | 14201-02 | 56   |
| 12622-14 | 111  | 12909-23 | 79   | 12931-51 | 81   | 14003-09 | 466  | 14104F10 | 520  | 14115-20 | 54   | 14201-04 | 56   |
| 12622-16 | 111  | 12915-25 | 79   | 12931-53 | 81   | 14003-16 | 466  | 14104F15 | 520  | 14117-10 | 54   | 14201-06 | 56   |
| 12622-18 | 111  | 12915-26 | 79   | 12932-22 | 82   | 14003-25 | 466  | 14105-02 | 53   | 14117-15 | 54   | 14201-10 | 56   |
| 12622-20 | 111  | 12915-35 | 79   | 12932-26 | 82   | 14003-36 | 466  | 14105-04 | 53   | 14117-20 | 54   | 14201-15 | 56   |
| 12622-23 | 111  | 12915-45 | 79   | 12940-02 | 107  | 14003-49 | 467  | 14105-06 | 53   | 14118-10 | 54   | 14201-20 | 56   |
| 12622-26 | 111  | 12916-25 | 79   | 12940-05 | 107  | 14004-00 | 467  | 14105-10 | 53   | 14118-15 | 54   | 14202-02 | 56   |
| 12630-22 | 111  | 12916-33 | 79   | 12940-10 | 107  | 14006-00 | 467  | 14105-15 | 53   | 14118-20 | 54   | 14202-04 | 56   |



| Cod.     | pag. | Cod.     | pag. | Cod.     | pag. | Cod.     | pag. | Cod.     | pag. | Cod.     | pag. | Cod.     | pag. |
|----------|------|----------|------|----------|------|----------|------|----------|------|----------|------|----------|------|
| 14202-06 | 56   | 14502F00 | 520  | 14565-15 | 61   | 14669-06 | 64   | 14718-00 | 66   | 14927-11 | 70   | 15108-10 | 22   |
| 14202-10 | 56   | 14503-00 | 57   | 14565-20 | 61   | 14669-10 | 64   | 14719-00 | 66   | 14927-22 | 70   | 15108-15 | 69   |
| 14202-15 | 56   | 14503F00 | 520  | 14567-06 | 62   | 14669-15 | 64   | 14722-00 | 67   | 14927-33 | 70   | 15108-20 | 69   |
| 14202-20 | 56   | 14504-00 | 57   | 14567-10 | 62   | 14669-20 | 64   | 14722-11 | 67   | 14927-77 | 22   | 15109-06 | 69   |
| 14203-06 | 56   | 14504F00 | 520  | 14567-15 | 62   | 14670-06 | 64   | 14722-22 | 67   | 14927-99 | 70   | 15109-10 | 22   |
| 14203-10 | 56   | 14505-00 | 57   | 14567-20 | 62   | 14670-10 | 64   | 14722-33 | 67   | 14928-00 | 70   | 15109-15 | 69   |
| 14203-15 | 56   | 14505F00 | 520  | 14568-06 | 62   | 14671-00 | 64   | 14722-99 | 67   | 14928-11 | 70   | 15109-20 | 69   |
| 14203-20 | 56   | 14507-00 | 57   | 14568-10 | 62   | 14672-00 | 64   | 14725-00 | 67   | 14928-22 | 70   | 15110-06 | 69   |
| 14205-02 | 56   | 14507F00 | 520  | 14568-15 | 62   | 14675-00 | 64   | 14725-11 | 67   | 14928-33 | 70   | 15110-10 | 22   |
| 14205-04 | 56   | 14508-00 | 57   | 14568-20 | 62   | 14677-00 | 64   | 14725-22 | 67   | 14928-77 | 22   | 15224-10 | 38   |
| 14205-06 | 56   | 14508F00 | 520  | 14569-06 | 62   | 14678-00 | 64   | 14725-33 | 67   | 14928-99 | 70   | 15224-12 | 38   |
| 14205-10 | 56   | 14509-00 | 57   | 14569-10 | 62   | 14679-00 | 64   | 14725-99 | 67   | 14929-00 | 70   | 15224-14 | 38   |
| 14205-15 | 56   | 14509F00 | 520  | 14569-15 | 62   | 14680-00 | 64   | 14727-00 | 67   | 14929-11 | 70   | 15225-10 | 38   |
| 14205-20 | 56   | 14510-00 | 57   | 14569-20 | 62   | 14682-00 | 64   | 14727-11 | 67   | 14929-22 | 70   | 15225-12 | 38   |
| 14252-06 | 56   | 14510F00 | 520  | 14570-06 | 62   | 14685-00 | 64   | 14727-22 | 67   | 14929-33 | 70   | 15225-14 | 38   |
| 14252-10 | 56   | 14512-00 | 57   | 14570-10 | 62   | 14687-00 | 64   | 14727-33 | 67   | 14929-77 | 22   | 15226-07 | 38   |
| 14252-15 | 56   | 14515-00 | 57   | 14571-00 | 62   | 14688-00 | 64   | 14727-99 | 67   | 14929-99 | 70   | 15226-10 | 38   |
| 14252-20 | 56   | 14517-00 | 57   | 14572-00 | 62   | 14689-00 | 64   | 14728-00 | 67   | 14930-00 | 70   | 15226-12 | 38   |
| 14255-06 | 56   | 14518-00 | 57   | 14575-00 | 62   | 14690-00 | 64   | 14728-11 | 67   | 14930-11 | 70   | 15226-14 | 38   |
| 14255-10 | 56   | 14519-00 | 57   | 14577-00 | 62   | 14691-00 | 64   | 14728-22 | 67   | 14930-22 | 70   | 15227-10 | 38   |
| 14255-15 | 56   | 14522-00 | 57   | 14578-00 | 62   | 14692-00 | 64   | 14728-33 | 67   | 14930-33 | 70   | 15227-12 | 38   |
| 14255-20 | 56   | 14523-00 | 57   | 14579-00 | 62   | 14695-00 | 64   | 14728-99 | 67   | 14930-77 | 22   | 15227-14 | 38   |
| 14301-02 | 58   | 14525-00 | 57   | 14580-00 | 62   | 14702-06 | 66   | 14729-00 | 67   | 14930-99 | 70   | 15228-10 | 38   |
| 14301-04 | 58   | 14527-00 | 57   | 14585-00 | 62   | 14702-10 | 66   | 14729-11 | 67   | 14942-99 | 69   | 15229-10 | 38   |
| 14301-06 | 58   | 14528-00 | 57   | 14591-00 | 62   | 14702-15 | 66   | 14729-22 | 67   | 14945-99 | 69   | 15261-10 | 38   |
| 14302-02 | 58   | 14529-00 | 57   | 14592-00 | 62   | 14702-20 | 66   | 14729-33 | 67   | 14947-99 | 69   | 15261-12 | 38   |
| 14302-04 | 58   | 14532-00 | 57   | 14595-00 | 62   | 14705-06 | 66   | 14729-99 | 67   | 14958-01 | 313  | 15261-14 | 38   |
| 14302-06 | 58   | 14535-00 | 57   | 14597-00 | 62   | 14705-10 | 66   | 14730-00 | 67   | 14958-02 | 313  | 15338-38 | 40   |
| 14303-02 | 58   | 14537-00 | 57   | 14598-00 | 62   | 14705-15 | 66   | 14730-11 | 67   | 15100-01 | 71   | 15339-36 | 40   |
| 14303-04 | 58   | 14538-00 | 57   | 14599-00 | 62   | 14705-20 | 66   | 14730-22 | 67   | 15100-02 | 71   | 15343-36 | 40   |
| 14303-06 | 58   | 14539-00 | 57   | 14661-20 | 63   | 14707-06 | 66   | 14730-33 | 67   | 15100-03 | 71   | 15401-51 | 40   |
| 14305-02 | 58   | 14542-00 | 57   | 14662-06 | 63   | 14707-10 | 66   | 14730-99 | 67   | 15100-04 | 71   | 15403-16 | 40   |
| 14305-04 | 58   | 14543-00 | 57   | 14662-10 | 63   | 14707-15 | 66   | 14912-00 | 69   | 15100-07 | 71   | 15406-16 | 40   |
| 14305-06 | 58   | 14545-00 | 57   | 14662-15 | 63   | 14707-20 | 66   | 14915-00 | 69   | 15100-AA | 71   | 15406-20 | 40   |
| 14362-02 | 58   | 14547-00 | 57   | 14662-20 | 63   | 14708-06 | 66   | 14922-00 | 70   | 15101-06 | 69   | 15407-16 | 40   |
| 14362-04 | 58   | 14548-00 | 57   | 14665-06 | 63   | 14708-10 | 66   | 14922-11 | 70   | 15101-10 | 22   | 15407-20 | 40   |
| 14362-06 | 58   | 14549-00 | 57   | 14665-10 | 63   | 14708-15 | 66   | 14922-22 | 70   | 15101-15 | 69   | 15409-26 | 40   |
| 14365-02 | 58   | 14552-00 | 58   | 14665-15 | 63   | 14708-20 | 66   | 14922-33 | 70   | 15101-20 | 69   | 15409-30 | 40   |
| 14365-04 | 58   | 14555-00 | 58   | 14665-20 | 63   | 14709-06 | 66   | 14922-77 | 22   | 15105-06 | 69   | 15409-36 | 40   |
| 14365-06 | 58   | 14561-15 | 61   | 14667-06 | 64   | 14709-10 | 66   | 14922-99 | 70   | 15105-10 | 22   | 15415-03 | 40   |
| 14402-00 | 60   | 14561-20 | 61   | 14667-10 | 64   | 14709-15 | 66   | 14925-00 | 70   | 15105-15 | 69   | 15428-06 | 359  |
| 14405-00 | 60   | 14562-06 | 61   | 14667-15 | 64   | 14709-20 | 66   | 14925-11 | 70   | 15105-20 | 69   | 15430-11 | 40   |
| 14407-00 | 60   | 14562-10 | 61   | 14667-20 | 64   | 14710-06 | 66   | 14925-22 | 70   | 15107-06 | 69   | 15438-50 | 40   |
| 14409-01 | 60   | 14562-15 | 61   | 14668-06 | 64   | 14710-10 | 66   | 14925-33 | 70   | 15107-10 | 22   | 15506-16 | 37   |
| 14409-02 | 60   | 14562-20 | 61   | 14668-10 | 64   | 14712-00 | 66   | 14925-77 | 22   | 15107-15 | 69   | 15506-20 | 37   |
| 14480-20 | 320  | 14565-06 | 61   | 14668-15 | 64   | 14715-00 | 66   | 14925-99 | 70   | 15107-20 | 69   | 15506-24 | 37   |
| 14502-00 | 57   | 14565-10 | 61   | 14668-20 | 64   | 14717-00 | 66   | 14927-00 | 70   | 15108-06 | 69   | 15506-28 | 37   |

**NUMERICAL INDEX INDICE NUMERICO NUMERISCH INDEX INDEX NUMERIQUE INDICE NUMERICO**

| Cod.     | pag. | Cod.     | pag. | Cod.     | pag. | Cod.     | pag. | Cod.     | pag. | Cod.     | pag. | Cod.     | pag. |
|----------|------|----------|------|----------|------|----------|------|----------|------|----------|------|----------|------|
| 15507-16 | 37   | 16109-28 | 30   | 16127-40 | 32   | 16927-40 | 108  | 16961-50 | 31   | 18002B26 | 141  | 18008-30 | 142  |
| 15507-20 | 37   | 16109-32 | 30   | 16134-12 | 41   | 16927-45 | 108  | 16961-60 | 31   | 18002R18 | 141  | 18008-36 | 142  |
| 15507-24 | 37   | 16109-36 | 30   | 16135-12 | 41   | 16927-50 | 108  | 16965-40 | 33   | 18002R20 | 141  | 18008B30 | 142  |
| 15507-28 | 37   | 16109-40 | 30   | 16136-10 | 41   | 16929-36 | 30   | 16965-50 | 33   | 18002R22 | 141  | 18008R26 | 142  |
| 15508-20 | 37   | 16109-45 | 30   | 16137-10 | 41   | 16929-40 | 30   | 16965-60 | 33   | 18002R26 | 141  | 18008R30 | 142  |
| 15508-24 | 37   | 16109-50 | 30   | 16138-10 | 41   | 16938-36 | 30   | 17610-01 | 107  | 18002R30 | 141  | 18008R36 | 142  |
| 15508-28 | 37   | 16109-60 | 30   | 16139-10 | 41   | 16938-40 | 30   | 17610-02 | 107  | 18002R36 | 141  | 18008Y30 | 143  |
| 15509-20 | 37   | 16113-20 | 32   | 16302-02 | 59   | 16938-45 | 30   | 17610-05 | 107  | 18002Y18 | 141  | 18009-25 | 143  |
| 15509-24 | 37   | 16113-24 | 32   | 16302-04 | 59   | 16939-50 | 33   | 17610-10 | 107  | 18002Y26 | 141  | 18009-30 | 143  |
| 15509-28 | 37   | 16113-28 | 32   | 16302-06 | 59   | 16939-60 | 33   | 18000-16 | 140  | 18002Y30 | 141  | 18009-36 | 143  |
| 15514-20 | 37   | 16113-32 | 32   | 16303-02 | 59   | 16939-70 | 33   | 18000-20 | 140  | 18002Y36 | 141  | 18009B25 | 143  |
| 15514-24 | 37   | 16113-36 | 32   | 16303-04 | 59   | 16939-80 | 33   | 18000-23 | 140  | 18005-22 | 140  | 18009B30 | 143  |
| 15514-28 | 37   | 16113-40 | 32   | 16303-06 | 59   | 16940-28 | 206  | 18000-26 | 140  | 18005-27 | 140  | 18009M25 | 143  |
| 15514-32 | 37   | 16114-20 | 31   | 16305-02 | 59   | 16940-32 | 206  | 18000-30 | 140  | 18005-32 | 140  | 18009R25 | 143  |
| 15515-20 | 37   | 16114-24 | 31   | 16305-04 | 59   | 16940-36 | 206  | 18000-36 | 140  | 18005B22 | 141  | 18009R30 | 143  |
| 15515-24 | 37   | 16114-28 | 31   | 16305-06 | 59   | 16940-40 | 206  | 18000B16 | 140  | 18005B27 | 141  | 18009W25 | 143  |
| 15515-28 | 37   | 16114-32 | 31   | 16362-02 | 59   | 16941-40 | 33   | 18000B20 | 140  | 18005B32 | 141  | 18009W30 | 143  |
| 15515-32 | 37   | 16114-36 | 31   | 16362-04 | 59   | 16941-45 | 33   | 18000B23 | 140  | 18005G22 | 141  | 18009Y25 | 143  |
| 15561-20 | 37   | 16114-40 | 31   | 16362-06 | 59   | 16941-50 | 33   | 18000B26 | 140  | 18005G27 | 141  | 18009Y30 | 143  |
| 15561-24 | 37   | 16115-24 | 31   | 16363-02 | 59   | 16941-60 | 33   | 18000B30 | 140  | 18005G32 | 141  | 18010-25 | 143  |
| 15561-28 | 37   | 16115-28 | 31   | 16363-04 | 59   | 16941-61 | 33   | 18000G16 | 140  | 18005R22 | 141  | 18010-30 | 143  |
| 16101-16 | 30   | 16115-32 | 31   | 16363-06 | 59   | 16943-40 | 33   | 18000G20 | 140  | 18005R27 | 141  | 18010-36 | 143  |
| 16101-20 | 30   | 16115-36 | 31   | 16365-02 | 59   | 16943-45 | 33   | 18000G23 | 140  | 18005R32 | 141  | 18010Y30 | 143  |
| 16101-24 | 30   | 16115-40 | 31   | 16365-04 | 59   | 16943-50 | 33   | 18000G26 | 140  | 18005Y22 | 141  | 18011-32 | 143  |
| 16101-28 | 30   | 16115-45 | 31   | 16365-06 | 59   | 16943-60 | 33   | 18000G30 | 140  | 18005Y27 | 141  | 18012-32 | 144  |
| 16101-32 | 30   | 16116-28 | 32   | 16712-22 | 33   | 16943-61 | 33   | 18000M16 | 140  | 18005Y32 | 141  | 18012B32 | 144  |
| 16101-36 | 30   | 16116-32 | 32   | 16712-26 | 33   | 16944-45 | 33   | 18000M20 | 140  | 18006-20 | 142  | 18013-30 | 144  |
| 16101-40 | 30   | 16116-36 | 32   | 16712-30 | 33   | 16944-50 | 33   | 18000M23 | 140  | 18006-25 | 142  | 18013-36 | 144  |
| 16101-45 | 30   | 16116-40 | 32   | 16717-20 | 32   | 16944-60 | 33   | 18000M26 | 140  | 18006-30 | 142  | 18013G36 | 144  |
| 16101-50 | 30   | 16117-20 | 32   | 16717-24 | 32   | 16947-40 | 33   | 18000R16 | 140  | 18006-36 | 142  | 18013W30 | 144  |
| 16106-16 | 30   | 16117-24 | 32   | 16717-28 | 32   | 16947-45 | 33   | 18000R20 | 140  | 18006B20 | 142  | 18013W36 | 144  |
| 16106-20 | 30   | 16117-28 | 32   | 16717-32 | 32   | 16947-50 | 33   | 18000R23 | 140  | 18006B25 | 142  | 18015-18 | 144  |
| 16106-24 | 30   | 16117-32 | 32   | 16717-36 | 32   | 16947-60 | 33   | 18000R26 | 140  | 18006B30 | 142  | 18015-22 | 144  |
| 16106-28 | 30   | 16117-36 | 32   | 16717-40 | 32   | 16947-61 | 33   | 18000R30 | 140  | 18006G20 | 142  | 18015-27 | 144  |
| 16107-16 | 30   | 16117-40 | 32   | 16719-12 | 33   | 16948-40 | 33   | 18000W20 | 140  | 18006G25 | 142  | 18015B18 | 144  |
| 16107-20 | 30   | 16118-24 | 32   | 16910-14 | 33   | 16948-45 | 33   | 18000W26 | 140  | 18006R20 | 142  | 18015B22 | 144  |
| 16107-24 | 30   | 16120-24 | 32   | 16910-16 | 33   | 16948-50 | 33   | 18000W30 | 140  | 18006R25 | 142  | 18015R18 | 144  |
| 16107-28 | 30   | 16120-28 | 32   | 16910-18 | 33   | 16948-60 | 33   | 18000Y16 | 140  | 18006R30 | 142  | 18015R22 | 144  |
| 16107-32 | 30   | 16120-32 | 32   | 16910-20 | 33   | 16948-61 | 33   | 18000Y20 | 140  | 18006Y20 | 142  | 18015Y18 | 144  |
| 16107-36 | 30   | 16120-36 | 32   | 16924-20 | 109  | 16961-16 | 31   | 18000Y23 | 140  | 18006Y25 | 142  | 18015Y27 | 144  |
| 16107-40 | 30   | 16120-40 | 32   | 16924-24 | 109  | 16961-20 | 31   | 18000Y26 | 140  | 18006Y30 | 142  | 18016-14 | 144  |
| 16107-45 | 30   | 16127-16 | 32   | 16924-28 | 109  | 16961-24 | 31   | 18002-18 | 141  | 18007-25 | 142  | 18016-16 | 144  |
| 16107-50 | 30   | 16127-20 | 32   | 16926-32 | 30   | 16961-28 | 31   | 18002-20 | 141  | 18007-30 | 142  | 18016B14 | 144  |
| 16108-20 | 30   | 16127-24 | 32   | 16926-36 | 30   | 16961-32 | 31   | 18002-22 | 141  | 18007-36 | 142  | 18016B16 | 144  |
| 16108-24 | 30   | 16127-28 | 32   | 16926-40 | 30   | 16961-36 | 31   | 18002-26 | 141  | 18007G30 | 142  | 18016R14 | 144  |
| 16108-28 | 30   | 16127-32 | 32   | 16927-32 | 108  | 16961-40 | 31   | 18002-30 | 141  | 18008-20 | 142  | 18016R16 | 144  |
| 16109-24 | 30   | 16127-36 | 32   | 16927-36 | 108  | 16961-45 | 31   | 18002-36 | 141  | 18008-26 | 142  | 18016W16 | 144  |

| Cod.     | pag. | Cod.     | pag. | Cod.     | pag. | Cod.     | pag. | Cod.     | pag. | Cod.     | pag. | Cod.     | pag. | Cod. | pag. |
|----------|------|----------|------|----------|------|----------|------|----------|------|----------|------|----------|------|------|------|
| 18016Y14 | 145  | 18028-30 | 147  | 18110-36 | 137  | 18136U33 | 447  | 18166-AF | 525  | 18176-40 | 444  | 18221-19 | 149  |      |      |
| 18016Y16 | 145  | 18028-36 | 147  | 18111-30 | 137  | 18136U34 | 449  | 18166-AH | 525  | 18176A30 | 446  | 18221-21 | 149  |      |      |
| 18017-14 | 145  | 18028B30 | 147  | 18112-30 | 137  | 18136U40 | 448  | 18166-AM | 453  | 18176A36 | 446  | 18221B17 | 149  |      |      |
| 18017-16 | 145  | 18028F21 | 521  | 18114-20 | 137  | 18136U41 | 449  | 18166E24 | 446  | 18176A40 | 446  | 18221B19 | 149  |      |      |
| 18017-18 | 145  | 18028F25 | 521  | 18115-20 | 138  | 18152A54 | 449  | 18166E30 | 446  | 18176-AE | 525  | 18221B21 | 149  |      |      |
| 18017B16 | 145  | 18028F30 | 521  | 18115-25 | 138  | 18152E54 | 449  | 18166E36 | 446  | 18176-AF | 525  | 18221G17 | 149  |      |      |
| 18017R16 | 145  | 18028F36 | 521  | 18116-14 | 138  | 18152U54 | 449  | 18166E40 | 446  | 18176-AH | 525  | 18221G19 | 149  |      |      |
| 18017Y16 | 145  | 18028M25 | 147  | 18116-18 | 138  | 18156A33 | 449  | 18166-EB | 454  | 18176E30 | 446  | 18221G21 | 149  |      |      |
| 18018-11 | 145  | 18028W21 | 147  | 18122-12 | 138  | 18156A40 | 449  | 18166-EC | 454  | 18176E36 | 446  | 18221M17 | 149  |      |      |
| 18018R11 | 145  | 18028W25 | 147  | 18123-11 | 138  | 18156E33 | 449  | 18166-ED | 454  | 18176E40 | 446  | 18221M19 | 149  |      |      |
| 18018Y11 | 145  | 18028W30 | 147  | 18124-09 | 138  | 18156E40 | 449  | 18166-EG | 454  | 18176I30 | 444  | 18221M21 | 149  |      |      |
| 18019-12 | 145  | 18028W36 | 147  | 18125-07 | 138  | 18156U33 | 449  | 18166-EH | 454  | 18176I36 | 444  | 18221R17 | 149  |      |      |
| 18019-14 | 145  | 18028Y25 | 147  | 18125-10 | 138  | 18156U40 | 449  | 18166-EI | 454  | 18176I40 | 444  | 18221R19 | 149  |      |      |
| 18019-16 | 145  | 18028Y30 | 147  | 18126-07 | 138  | 18162-54 | 445  | 18166-EJ | 454  | 18176U36 | 446  | 18221R21 | 149  |      |      |
| 18019-18 | 145  | 18029-25 | 146  | 18128-20 | 138  | 18162-56 | 445  | 18166-EL | 454  | 18176U40 | 446  | 18221Y17 | 149  |      |      |
| 18019-20 | 145  | 18029-30 | 146  | 18128-24 | 138  | 18162A54 | 447  | 18166-EM | 454  | 18190-09 | 158  | 18221Y19 | 149  |      |      |
| 18019R12 | 145  | 18029-36 | 146  | 18128-30 | 138  | 18162A55 | 445  | 18166I30 | 444  | 18190-AA | 525  | 18221Y21 | 149  |      |      |
| 18019R16 | 145  | 18029W25 | 146  | 18132A54 | 448  | 18162A56 | 447  | 18166I36 | 444  | 18191-22 | 158  | 18222-18 | 151  |      |      |
| 18019R18 | 145  | 18029W30 | 146  | 18132A55 | 448  | 18162A57 | 445  | 18166I40 | 444  | 18192-09 | 158  | 18224-28 | 150  |      |      |
| 18019R20 | 145  | 18029W36 | 146  | 18132-AE | 455  | 18162-AA | 453  | 18166-KE | 455  | 18199-19 | 157  | 18224B28 | 150  |      |      |
| 18020-23 | 145  | 18030-26 | 147  | 18132-AU | 455  | 18162-AF | 524  | 18166-KP | 455  | 18201-36 | 150  | 18224R28 | 150  |      |      |
| 18020B23 | 145  | 18030-31 | 147  | 18132E54 | 448  | 18162-AG | 524  | 18166-KU | 455  | 18203-26 | 151  | 18224Y28 | 150  |      |      |
| 18020R23 | 145  | 18030-36 | 147  | 18132E55 | 448  | 18162E54 | 447  | 18166U24 | 446  | 18205-10 | 150  | 18225-28 | 150  |      |      |
| 18021-18 | 145  | 18030W26 | 147  | 18132-FB | 454  | 18162E55 | 445  | 18166U36 | 446  | 18205-12 | 150  | 18225R28 | 150  |      |      |
| 18021B18 | 145  | 18030W31 | 147  | 18132-KA | 454  | 18162E56 | 445  | 18166U40 | 446  | 18206-09 | 150  | 18226-17 | 151  |      |      |
| 18021R18 | 145  | 18030W36 | 147  | 18132-KE | 455  | 18162E57 | 445  | 18168A24 | 446  | 18207-15 | 150  | 18226B17 | 151  |      |      |
| 18022-12 | 145  | 18099-15 | 157  | 18132-KP | 524  | 18162-KE | 455  | 18168E24 | 446  | 18209-06 | 150  | 18226G17 | 151  |      |      |
| 18023-11 | 145  | 18100-16 | 137  | 18132-KQ | 524  | 18162-KU | 455  | 18168-GA | 453  | 18215-13 | 151  | 18226R17 | 151  |      |      |
| 18024-08 | 146  | 18100-20 | 137  | 18132-KU | 455  | 18162-RA | 453  | 18168U24 | 446  | 18215-21 | 151  | 18226W17 | 151  |      |      |
| 18024-11 | 146  | 18100-24 | 137  | 18132U54 | 448  | 18162-RB | 453  | 18172-54 | 444  | 18217-12 | 146  | 18226Y17 | 151  |      |      |
| 18024B08 | 146  | 18100-30 | 137  | 18132U55 | 448  | 18162U54 | 447  | 18172-56 | 444  | 18220-18 | 149  | 18230-13 | 138  |      |      |
| 18024B11 | 146  | 18100-36 | 137  | 18136A33 | 448  | 18162U55 | 445  | 18172A54 | 447  | 18220-20 | 149  | 18230-17 | 138  |      |      |
| 18024G08 | 146  | 18102-16 | 137  | 18136A34 | 449  | 18162U56 | 447  | 18172A55 | 445  | 18220-22 | 149  | 18231-13 | 138  |      |      |
| 18024G11 | 146  | 18102-20 | 137  | 18136A40 | 448  | 18162U57 | 445  | 18172A56 | 447  | 18220-26 | 149  | 18235-26 | 152  |      |      |
| 18024M08 | 146  | 18102-26 | 137  | 18136A41 | 449  | 18166-24 | 444  | 18172A57 | 445  | 18220B18 | 149  | 18235-30 | 152  |      |      |
| 18024M11 | 146  | 18102-30 | 137  | 18136E33 | 448  | 18166-30 | 444  | 18172-AF | 525  | 18220B20 | 149  | 18235B30 | 152  |      |      |
| 18024R08 | 146  | 18103-18 | 137  | 18136E34 | 449  | 18166-36 | 444  | 18172-AG | 525  | 18220B22 | 149  | 18235G30 | 152  |      |      |
| 18024R11 | 146  | 18104-18 | 137  | 18136E40 | 448  | 18166-40 | 444  | 18172E54 | 447  | 18220B26 | 149  | 18235R30 | 152  |      |      |
| 18024W08 | 146  | 18106-15 | 137  | 18136E41 | 449  | 18166A24 | 446  | 18172E55 | 445  | 18220R18 | 150  | 18235W30 | 152  |      |      |
| 18024W11 | 146  | 18106-20 | 137  | 18136-EA | 454  | 18166A30 | 446  | 18172E56 | 447  | 18220R20 | 150  | 18235Y30 | 152  |      |      |
| 18024Y08 | 146  | 18106-25 | 137  | 18136-EB | 454  | 18166A36 | 446  | 18172E57 | 445  | 18220R22 | 150  | 18236-30 | 152  |      |      |
| 18026-07 | 146  | 18106-30 | 137  | 18136-KA | 454  | 18166A40 | 446  | 18172U54 | 447  | 18220R26 | 150  | 18237-26 | 152  |      |      |
| 18026B07 | 146  | 18109-26 | 137  | 18136-KE | 455  | 18166-AA | 453  | 18172U55 | 445  | 18220Y18 | 150  | 18251-01 | 152  |      |      |
| 18026G07 | 146  | 18109-30 | 137  | 18136-KP | 524  | 18166-AB | 453  | 18172U56 | 447  | 18220Y20 | 150  | 18251-02 | 152  |      |      |
| 18026M07 | 146  | 18109-36 | 137  | 18136-KQ | 524  | 18166-AC | 453  | 18172U57 | 445  | 18220Y22 | 150  | 18255-00 | 157  |      |      |
| 18028-21 | 147  | 18110-26 | 137  | 18136-KR | 524  | 18166-AD | 525  | 18176-30 | 444  | 18220Y26 | 150  | 18261-00 | 152  |      |      |
| 18028-25 | 147  | 18110-30 | 137  | 18136-KU | 455  | 18166-AE | 525  | 18176-36 | 444  | 18221-17 | 149  | 18263-00 | 152  |      |      |

**NUMERICAL INDEX INDICE NUMERICO NUMERISCH INDEX INDEX NUMERIQUE INDICE NUMERICO**

| Cod.     | pag. | Cod.     | pag. | Cod.     | pag. | Cod.     | pag. | Cod.     | pag. | Cod.     | pag. | Cod.     | pag. |
|----------|------|----------|------|----------|------|----------|------|----------|------|----------|------|----------|------|
| 18270-22 | 153  | 18502-18 | 271  | 18876M01 | 458  | 18891N00 | 460  | 41200-14 | 337  | 41208-02 | 280  | 41323-24 | 330  |
| 18271-00 | 153  | 18503-12 | 271  | 18876N00 | 457  | 18891R00 | 460  | 41200-15 | 337  | 41208-06 | 280  | 41323-99 | 330  |
| 18272-00 | 153  | 18504-15 | 271  | 18876N01 | 458  | 18893-00 | 461  | 41200-16 | 337  | 41210-01 | 42   | 41323-AA | 526  |
| 18273-00 | 153  | 18509-01 | 96   | 18876R00 | 457  | 18893M00 | 461  | 41200-17 | 337  | 41210-03 | 42   | 41325-20 | 333  |
| 18274-00 | 153  | 18509-02 | 96   | 18876R01 | 458  | 18893N00 | 461  | 41200-18 | 338  | 41210-05 | 42   | 41325-30 | 333  |
| 18275-00 | 152  | 18509-03 | 96   | 18877-00 | 458  | 18893R00 | 461  | 41200-32 | 338  | 41210-07 | 42   | 41325-40 | 333  |
| 18276-00 | 154  | 18510-07 | 96   | 18877M00 | 458  | 18895-00 | 460  | 41200-33 | 338  | 41210-08 | 42   | 41326-30 | 333  |
| 18277-00 | 117  | 18510F07 | 521  | 18877N00 | 458  | 18895M00 | 460  | 41200-34 | 338  | 41210-10 | 42   | 41326-36 | 333  |
| 18278-00 | 153  | 18511-15 | 95   | 18877R00 | 458  | 18895N00 | 460  | 41200-36 | 338  | 41210-12 | 42   | 41326-42 | 333  |
| 18279-14 | 153  | 18511F15 | 521  | 18878-00 | 458  | 18895R00 | 460  | 41200-40 | 338  | 41210-13 | 42   | 41327-01 | 332  |
| 18280-10 | 156  | 18512-15 | 95   | 18878M00 | 458  | 18897-00 | 460  | 41200-41 | 338  | 41210-14 | 42   | 41327-02 | 332  |
| 18280-16 | 156  | 18513-14 | 96   | 18878N00 | 458  | 18897M00 | 460  | 41200-46 | 338  | 41220-01 | 427  | 41327-03 | 332  |
| 18280-22 | 156  | 18513F14 | 521  | 18878R00 | 458  | 18897N00 | 460  | 41200-47 | 338  | 41220-02 | 426  | 41327-04 | 332  |
| 18281-24 | 156  | 18514-17 | 96   | 18879-00 | 459  | 18897R00 | 460  | 41200-48 | 338  | 41220-03 | 426  | 41327-05 | 332  |
| 18282-18 | 156  | 18514-18 | 96   | 18879M00 | 459  | 19701-00 | 128  | 41200-49 | 338  | 41220-04 | 427  | 41327-06 | 332  |
| 18282-19 | 156  | 18515-16 | 95   | 18879N00 | 459  | 19702-00 | 127  | 41200-50 | 338  | 41220-05 | 427  | 41327-07 | 332  |
| 18282-22 | 156  | 18516-24 | 96   | 18879R00 | 459  | 19705-00 | 127  | 41200-51 | 338  | 41220-06 | 426  | 41327-08 | 332  |
| 18283-27 | 156  | 18517-24 | 96   | 18880-00 | 459  | 19706-00 | 127  | 41200-52 | 338  | 41220-07 | 427  | 41327-09 | 332  |
| 18283-33 | 156  | 18518-22 | 96   | 18880M00 | 459  | 19709-00 | 127  | 41200-53 | 338  | 41311-00 | 359  | 41327-10 | 332  |
| 18284-21 | 156  | 18518-26 | 96   | 18880N00 | 459  | 19810-00 | 125  | 41200-54 | 338  | 41311-AA | 526  | 41380-01 | 133  |
| 18284-27 | 156  | 18518-30 | 96   | 18880R00 | 459  | 19810-AA | 525  | 41200-55 | 338  | 41311-AB | 526  | 41380-02 | 133  |
| 18284-30 | 156  | 18519-15 | 96   | 18882-00 | 459  | 19810-AB | 525  | 41200-56 | 338  | 41312-00 | 359  | 41390-00 | 368  |
| 18284-33 | 156  | 18519-22 | 96   | 18882M00 | 459  | 19901-35 | 461  | 41200-57 | 338  | 41313-00 | 360  | 41394-02 | 367  |
| 18301-01 | 267  | 18519-26 | 96   | 18882N00 | 459  | 19901-40 | 461  | 41200-58 | 338  | 41314-00 | 360  | 41400-AA | 430  |
| 18301-02 | 267  | 18519-30 | 96   | 18882R00 | 459  | 19901-47 | 461  | 41200-59 | 338  | 41315-02 | 359  | 41400-AB | 526  |
| 18302-01 | 267  | 18519-35 | 96   | 18884-00 | 459  | 19902-38 | 461  | 41200-60 | 338  | 41315-04 | 359  | 41402-AA | 526  |
| 18302-02 | 267  | 18520-04 | 96   | 18884M00 | 459  | 32931-02 | 365  | 41200-61 | 338  | 41317-20 | 360  | 41403-01 | 73   |
| 18323-00 | 267  | 18520-06 | 96   | 18884N00 | 459  | 32931-03 | 365  | 41200-62 | 338  | 41318-00 | 358  | 41403-02 | 73   |
| 18324-00 | 267  | 18520-08 | 96   | 18884R00 | 459  | 32931-05 | 365  | 41200-63 | 338  | 41320-25 | 332  | 41403-03 | 73   |
| 18324-10 | 84   | 18520-10 | 96   | 18886-00 | 457  | 32935-03 | 366  | 41200-64 | 338  | 41320-30 | 332  | 41403-04 | 73   |
| 18324F10 | 521  | 18520-12 | 96   | 18886M00 | 457  | 32935-05 | 366  | 41205-01 | 329  | 41320-35 | 332  | 41405-AA | 430  |
| 18325-01 | 196  | 18520-15 | 271  | 18886N00 | 457  | 32935-10 | 366  | 41205-02 | 329  | 41321-40 | 333  | 41405-AB | 526  |
| 18325-02 | 196  | 18874-11 | 457  | 18886R00 | 457  | 32935-22 | 366  | 41205-03 | 329  | 41321-44 | 333  | 41412-11 | 429  |
| 18325-03 | 196  | 18874-22 | 457  | 18887-00 | 457  | 32936-03 | 366  | 41205-04 | 329  | 41322-19 | 333  | 41413-30 | 282  |
| 18341-KE | 455  | 18874M11 | 457  | 18887M00 | 457  | 32936-05 | 366  | 41205-05 | 329  | 41322-25 | 333  | 41414-21 | 281  |
| 18341-KU | 455  | 18874M22 | 457  | 18887N00 | 457  | 41200-01 | 337  | 41205-06 | 329  | 41322-31 | 333  | 41414-30 | 280  |
| 18353-17 | 438  | 18874N11 | 457  | 18887R00 | 457  | 41200-02 | 337  | 41205-07 | 328  | 41323-01 | 330  | 41414-31 | 281  |
| 18353-AA | 525  | 18874N22 | 457  | 18888-00 | 461  | 41200-03 | 337  | 41205-08 | 328  | 41323-02 | 330  | 41414-36 | 281  |
| 18353-BB | 525  | 18874R11 | 457  | 18888M00 | 461  | 41200-04 | 337  | 41205-09 | 328  | 41323-03 | 330  | 41415-10 | 429  |
| 18353-CA | 525  | 18874R22 | 457  | 18888N00 | 461  | 41200-05 | 337  | 41205-10 | 329  | 41323-04 | 330  | 41415-11 | 425  |
| 18353-DB | 525  | 18875-00 | 458  | 18888R00 | 461  | 41200-06 | 337  | 41206-01 | 333  | 41323-11 | 330  | 41416-18 | 283  |
| 18353-VA | 525  | 18875M00 | 458  | 18889-00 | 460  | 41200-07 | 337  | 41206-02 | 333  | 41323-12 | 330  | 41418-11 | 425  |
| 18501-01 | 271  | 18875N00 | 458  | 18889M00 | 460  | 41200-08 | 337  | 41206-03 | 280  | 41323-13 | 330  | 41418-12 | 425  |
| 18501-02 | 271  | 18875R00 | 458  | 18889N00 | 460  | 41200-09 | 337  | 41206-04 | 329  | 41323-14 | 330  | 41419-12 | 425  |
| 18501-03 | 271  | 18876-00 | 458  | 18889R00 | 460  | 41200-10 | 337  | 41206-05 | 437  | 41323-21 | 330  | 41425-AA | 431  |
| 18501-04 | 271  | 18876-01 | 458  | 18891-00 | 460  | 41200-11 | 337  | 41207-02 | 334  | 41323-22 | 330  | 41427-40 | 431  |
| 18501-05 | 271  | 18876M00 | 458  | 18891M00 | 460  | 41200-13 | 337  | 41207-03 | 334  | 41323-23 | 330  | 41429-04 | 431  |



| Cod.     | pag. | Cod.     | pag. | Cod.     | pag. | Cod.     | pag. | Cod.     | pag. | Cod.     | pag. | Cod.     | pag. |
|----------|------|----------|------|----------|------|----------|------|----------|------|----------|------|----------|------|
| 41430-11 | 418  | 41458-24 | 296  | 41472-12 | 278  | 41474-00 | 287  | 41490-01 | 302  | 41503-00 | 313  | 41523-08 | 327  |
| 41431-08 | 286  | 41458-25 | 296  | 41472-13 | 278  | 41474-02 | 287  | 41490-AA | 302  | 41503-21 | 313  | 41523-09 | 327  |
| 41431-12 | 286  | 41458-50 | 296  | 41472-14 | 290  | 41475-00 | 286  | 41490B00 | 302  | 41503-22 | 313  | 41523G08 | 328  |
| 41436-11 | 419  | 41458-51 | 296  | 41472-15 | 290  | 41475-01 | 286  | 41490B01 | 302  | 41504-09 | 364  | 41523G09 | 328  |
| 41436-12 | 419  | 41459-10 | 295  | 41472-16 | 289  | 41475-03 | 286  | 41490C00 | 302  | 41504-10 | 364  | 41524-04 | 327  |
| 41442-03 | 435  | 41460-05 | 295  | 41472-17 | 289  | 41475-04 | 286  | 41490C01 | 302  | 41504-11 | 364  | 41524-09 | 327  |
| 41442-14 | 433  | 41460-10 | 295  | 41472-18 | 289  | 41475-05 | 286  | 41490G00 | 302  | 41504-12 | 364  | 41524-10 | 328  |
| 41442-23 | 433  | 41461-07 | 307  | 41472-19 | 290  | 41475-20 | 286  | 41490G01 | 302  | 41504-19 | 364  | 41524-11 | 328  |
| 41443-AE | 526  | 41461B07 | 307  | 41472-20 | 289  | 41476-50 | 287  | 41491C00 | 303  | 41505-17 | 363  | 41524-12 | 328  |
| 41445-01 | 437  | 41461C07 | 307  | 41472-21 | 289  | 41477-50 | 308  | 41491C01 | 303  | 41505-19 | 363  | 41524C10 | 328  |
| 41445-02 | 437  | 41461G07 | 307  | 41472-22 | 289  | 41478-35 | 308  | 41491C02 | 303  | 41505-20 | 363  | 41524C11 | 328  |
| 41445-22 | 410  | 41463-01 | 298  | 41472-23 | 290  | 41478-50 | 308  | 41491C03 | 304  | 41507-01 | 364  | 41524C12 | 328  |
| 41445-26 | 410  | 41463-02 | 299  | 41472-24 | 289  | 41479-05 | 307  | 41491C04 | 304  | 41508-10 | 364  | 41525-00 | 277  |
| 41445-30 | 411  | 41463A00 | 300  | 41472-25 | 278  | 41479-11 | 307  | 41491C05 | 304  | 41508C12 | 363  | 41525-01 | 277  |
| 41446-18 | 410  | 41463A05 | 299  | 41472-26 | 289  | 41479-12 | 307  | 41491C06 | 304  | 41510-08 | 364  | 41526-01 | 106  |
| 41446-23 | 410  | 41463A30 | 299  | 41472-27 | 289  | 41479-13 | 307  | 41491G00 | 303  | 41511-00 | 365  | 41526-02 | 106  |
| 41447-02 | 428  | 41463A50 | 299  | 41472-28 | 289  | 41479-14 | 307  | 41491G01 | 303  | 41511-20 | 365  | 41526-05 | 106  |
| 41447-05 | 428  | 41463B05 | 299  | 41472-29 | 289  | 41479-15 | 307  | 41491G02 | 303  | 41511-30 | 365  | 41526-06 | 106  |
| 41447-38 | 281  | 41463C00 | 300  | 41472-32 | 283  | 41479-AA | 308  | 41491G03 | 304  | 41512-15 | 315  | 41526-B1 | 106  |
| 41447-39 | 526  | 41463C30 | 299  | 41472-33 | 293  | 41480-03 | 306  | 41491G04 | 304  | 41512-30 | 315  | 41526-B2 | 106  |
| 41448-06 | 432  | 41463C50 | 299  | 41472-34 | 293  | 41480-05 | 306  | 41491G05 | 304  | 41512-50 | 315  | 41526-B3 | 106  |
| 41448-10 | 432  | 41463G05 | 299  | 41472-35 | 293  | 41480-07 | 306  | 41491G06 | 304  | 41513-13 | 315  | 41526-G1 | 106  |
| 41448-25 | 432  | 41463M05 | 299  | 41472-36 | 293  | 41480B05 | 307  | 41492-00 | 326  | 41513B20 | 315  | 41526-G2 | 106  |
| 41448-40 | 432  | 41464-09 | 307  | 41472-37 | 294  | 41480C05 | 307  | 41492B00 | 326  | 41513C20 | 315  | 41526-G3 | 106  |
| 41449-27 | 433  | 41464B09 | 307  | 41472-38 | 294  | 41480G05 | 307  | 41492C00 | 326  | 41513G20 | 315  | 41526-R1 | 106  |
| 41449-32 | 434  | 41464C09 | 307  | 41472-39 | 294  | 41481-02 | 306  | 41492G00 | 326  | 41514-05 | 308  | 41526-R2 | 106  |
| 41450-AA | 295  | 41464G09 | 307  | 41472-40 | 294  | 41481-03 | 306  | 41493B00 | 298  | 41514-10 | 308  | 41526-R3 | 106  |
| 41451-05 | 295  | 41465-10 | 313  | 41472-41 | 294  | 41483-04 | 306  | 41493C00 | 298  | 41515-03 | 314  | 41527-10 | 327  |
| 41451-10 | 295  | 41467B08 | 307  | 41472-42 | 294  | 41483-06 | 306  | 41493G00 | 298  | 41515-05 | 314  | 41527-11 | 327  |
| 41452N10 | 276  | 41467C08 | 307  | 41472-43 | 287  | 41484-05 | 306  | 41494B00 | 298  | 41515-07 | 314  | 41527-12 | 327  |
| 41452N16 | 276  | 41467G08 | 307  | 41472-44 | 287  | 41484B05 | 306  | 41494C00 | 298  | 41515-08 | 314  | 41527-13 | 327  |
| 41453-11 | 313  | 41468-20 | 286  | 41472-45 | 288  | 41484C05 | 306  | 41494G00 | 298  | 41515-09 | 314  | 41527G10 | 328  |
| 41453-AA | 313  | 41468-24 | 286  | 41472-46 | 287  | 41484G05 | 306  | 41495-08 | 303  | 41515-10 | 314  | 41527G11 | 328  |
| 41454-01 | 313  | 41469-20 | 286  | 41472-47 | 294  | 41486-00 | 286  | 41495-10 | 303  | 41515-20 | 314  | 41527G12 | 328  |
| 41454-99 | 313  | 41469-24 | 286  | 41472-48 | 294  | 41486-01 | 286  | 41496-40 | 365  | 41515-21 | 314  | 41527G13 | 328  |
| 41455-BC | 295  | 41470A00 | 301  | 41472-50 | 294  | 41486-08 | 286  | 41497-05 | 300  | 41515-22 | 314  | 41528-21 | 106  |
| 41455-CA | 296  | 41470A03 | 301  | 41472-55 | 284  | 41486-12 | 286  | 41497B05 | 300  | 41518-00 | 362  | 41528-22 | 106  |
| 41455-CB | 296  | 41470C00 | 301  | 41472-56 | 284  | 41486-15 | 286  | 41497C05 | 300  | 41518-01 | 362  | 41529-05 | 352  |
| 41455T55 | 295  | 41470C03 | 301  | 41472-80 | 284  | 41487-12 | 286  | 41497G05 | 300  | 41518-02 | 362  | 41530-05 | 352  |
| 41456-02 | 312  | 41471-00 | 286  | 41472-99 | 284  | 41487-15 | 286  | 41498B00 | 298  | 41518B12 | 315  | 41530-07 | 352  |
| 41457-00 | 313  | 41471-12 | 286  | 41473-31 | 287  | 41487-17 | 286  | 41498C00 | 298  | 41518C12 | 315  | 41530-11 | 352  |
| 41458-02 | 295  | 41471-15 | 286  | 41473-39 | 287  | 41488-45 | 287  | 41498G00 | 298  | 41518G12 | 315  | 41538-30 | 280  |
| 41458-05 | 295  | 41471-17 | 286  | 41473-44 | 287  | 41488-47 | 287  | 41499-08 | 365  | 41520-08 | 107  | 41541-44 | 416  |
| 41458-10 | 295  | 41472-01 | 288  | 41473-50 | 287  | 41488-50 | 287  | 41500-00 | 324  | 41520-12 | 107  | 41558-00 | 363  |
| 41458-11 | 296  | 41472-04 | 288  | 41473-56 | 287  | 41488-53 | 287  | 41500-AA | 324  | 41520-16 | 107  | 41559-04 | 363  |
| 41458-21 | 296  | 41472-07 | 288  | 41473-62 | 287  | 41489-20 | 286  | 41501-20 | 363  | 41520-24 | 107  | 41560-28 | 358  |
| 41458-23 | 295  | 41472-08 | 288  | 41473-66 | 287  | 41490-00 | 302  | 41502-20 | 363  | 41522-14 | 327  | 41561-09 | 352  |

**NUMERICAL INDEX INDICE NUMERICO NUMERISCH INDEX INDEX NUMERIQUE INDICE NUMERICO**

| Cod.     | pag. | Cod.     | pag. | Cod.     | pag. | Cod.     | pag. | Cod.     | pag. | Cod.     | pag. | Cod.     | pag. |
|----------|------|----------|------|----------|------|----------|------|----------|------|----------|------|----------|------|
| 41562-18 | 362  | 41589-58 | 348  | 41605-00 | 304  | 41638-91 | 527  | 41676-00 | 100  | 41707-32 | 35   | 41743D32 | 191  |
| 41563-07 | 352  | 41589-59 | 348  | 41605-01 | 304  | 41638-92 | 527  | 41677-00 | 100  | 41707-36 | 35   | 41743D53 | 191  |
| 41563-AA | 527  | 41589-99 | 348  | 41605-03 | 304  | 41638-93 | 527  | 41678-00 | 100  | 41707-40 | 35   | 41743D60 | 191  |
| 41564-07 | 352  | 41589-AA | 349  | 41605B03 | 304  | 41638-94 | 527  | 41678-14 | 365  | 41707-45 | 35   | 41744-32 | 190  |
| 41564-AA | 527  | 41589-AB | 349  | 41605B27 | 304  | 41638-95 | 527  | 41679-23 | 358  | 41707-50 | 35   | 41744-53 | 190  |
| 41569-33 | 360  | 41589-AC | 349  | 41605C03 | 304  | 41639-11 | 357  | 41680-03 | 316  | 41708-32 | 35   | 41744-60 | 190  |
| 41570-10 | 111  | 41589-BB | 349  | 41605G03 | 304  | 41639-17 | 357  | 41680-06 | 316  | 41708-36 | 35   | 41745-30 | 273  |
| 41570B10 | 305  | 41589C08 | 349  | 41605G27 | 304  | 41639-30 | 357  | 41680-12 | 316  | 41708-40 | 35   | 41745-35 | 273  |
| 41570C10 | 305  | 41589C16 | 349  | 41606-00 | 312  | 41639-31 | 357  | 41681-01 | 317  | 41708-45 | 35   | 41745-40 | 273  |
| 41570G10 | 305  | 41589-CC | 349  | 41606-01 | 312  | 41639-32 | 357  | 41681-02 | 317  | 41708-50 | 35   | 41745-50 | 273  |
| 41582-00 | 162  | 41591-32 | 362  | 41606-02 | 312  | 41639-40 | 358  | 41681-03 | 317  | 41717-60 | 35   | 41745-60 | 273  |
| 41583-00 | 163  | 41591-36 | 362  | 41606-22 | 312  | 41639-41 | 358  | 41681-04 | 317  | 41719-36 | 35   | 41745-65 | 273  |
| 41585-00 | 343  | 41591-40 | 362  | 41607-00 | 277  | 41639-42 | 358  | 41681-06 | 317  | 41719-40 | 35   | 41746-60 | 190  |
| 41585-01 | 343  | 41591-45 | 362  | 41608-00 | 323  | 41645-00 | 277  | 41681-10 | 316  | 41720-18 | 32   | 41747-60 | 191  |
| 41585-02 | 343  | 41591-90 | 362  | 41608-03 | 323  | 41646-06 | 349  | 41681-11 | 317  | 41720-20 | 32   | 41748-20 | 191  |
| 41585-03 | 343  | 41592-36 | 362  | 41608-04 | 323  | 41646-10 | 349  | 41681-12 | 317  | 41720-24 | 32   | 41748-30 | 191  |
| 41585-10 | 343  | 41592-45 | 362  | 41608-08 | 323  | 41646-15 | 349  | 41681-99 | 317  | 41720-28 | 32   | 41748-35 | 191  |
| 41585-11 | 342  | 41593-20 | 362  | 41608-20 | 323  | 41646-20 | 349  | 41683-26 | 104  | 41720-30 | 32   | 41748-40 | 191  |
| 41585-12 | 342  | 41594-12 | 361  | 41609-36 | 305  | 41650-06 | 349  | 41686-12 | 361  | 41720-32 | 32   | 41748-50 | 191  |
| 41585-13 | 342  | 41594-18 | 361  | 41609-75 | 305  | 41650-10 | 349  | 41690A11 | 449  | 41727-28 | 272  | 41750-20 | 191  |
| 41585-23 | 342  | 41595-20 | 305  | 41609B36 | 305  | 41650-13 | 349  | 41690E11 | 449  | 41727-30 | 272  | 41750-30 | 191  |
| 41585-24 | 342  | 41595B44 | 113  | 41609C36 | 305  | 41651-20 | 419  | 41690U11 | 449  | 41727-33 | 272  | 41750-40 | 191  |
| 41585-25 | 342  | 41595B45 | 113  | 41609G36 | 305  | 41651-25 | 419  | 41691A11 | 449  | 41727-36 | 272  | 41750-41 | 191  |
| 41585-30 | 342  | 41597-04 | 352  | 41611-20 | 311  | 41651-30 | 419  | 41691E11 | 449  | 41727-40 | 272  | 41750-50 | 191  |
| 41585-37 | 342  | 41598-00 | 352  | 41614-22 | 278  | 41651-35 | 419  | 41691U11 | 449  | 41727-45 | 272  | 41751-30 | 190  |
| 41585-45 | 343  | 41599-08 | 352  | 41614-33 | 278  | 41651-40 | 419  | 41695-10 | 455  | 41727-50 | 272  | 41751-35 | 190  |
| 41585-51 | 343  | 41600-00 | 305  | 41614-34 | 278  | 41651-45 | 419  | 41695-15 | 455  | 41727-55 | 272  | 41751-40 | 190  |
| 41585-52 | 343  | 41600C00 | 305  | 41614-35 | 278  | 41651-50 | 419  | 41695-50 | 455  | 41727-60 | 272  | 41751-50 | 190  |
| 41585-53 | 343  | 41600G00 | 305  | 41614-36 | 278  | 41651-55 | 419  | 41695-90 | 455  | 41729-30 | 209  | 41751-60 | 190  |
| 41585-54 | 343  | 41601-17 | 279  | 41615-01 | 353  | 41651-60 | 419  | 41697-00 | 102  | 41729-34 | 209  | 41751-65 | 190  |
| 41586-22 | 343  | 41602-00 | 279  | 41615-03 | 353  | 41651-65 | 419  | 41698-22 | 102  | 41734-60 | 272  | 41751F30 | 522  |
| 41586-28 | 343  | 41603-00 | 305  | 41615-05 | 353  | 41654-80 | 419  | 41698-30 | 102  | 41735-20 | 265  | 41751F40 | 522  |
| 41586-33 | 343  | 41603-07 | 305  | 41617-05 | 279  | 41654-99 | 419  | 41698-40 | 102  | 41735-29 | 264  | 41751F60 | 522  |
| 41586-38 | 343  | 41603B00 | 305  | 41617-15 | 279  | 41659-06 | 206  | 41699-03 | 325  | 41736-32 | 265  | 41752-08 | 274  |
| 41587-25 | 343  | 41603B07 | 305  | 41618-14 | 279  | 41659-07 | 206  | 41699-04 | 325  | 41737-17 | 265  | 41752-12 | 274  |
| 41587-32 | 343  | 41603C00 | 305  | 41620-04 | 352  | 41659-08 | 206  | 41699-06 | 324  | 41737-20 | 265  | 41752-24 | 274  |
| 41589-07 | 348  | 41603C07 | 305  | 41628-15 | 365  | 41660-10 | 205  | 41699-10 | 324  | 41737-23 | 265  | 41753-30 | 191  |
| 41589-08 | 347  | 41603G00 | 305  | 41629-17 | 353  | 41660-15 | 205  | 41699-12 | 325  | 41737G20 | 22   | 41753-32 | 191  |
| 41589-14 | 347  | 41603G07 | 305  | 41629-20 | 353  | 41670-06 | 100  | 41699-13 | 325  | 41737G23 | 22   | 41753-53 | 191  |
| 41589-15 | 348  | 41604-00 | 305  | 41629-25 | 353  | 41670-09 | 100  | 41699-18 | 325  | 41738-17 | 265  | 41753-60 | 191  |
| 41589-16 | 347  | 41604-01 | 306  | 41635-02 | 356  | 41670-AA | 100  | 41699-20 | 324  | 41738-20 | 265  | 41753D30 | 191  |
| 41589-20 | 347  | 41604B00 | 305  | 41636-25 | 356  | 41670-AB | 100  | 41699B18 | 325  | 41738-23 | 265  | 41753D32 | 191  |
| 41589-22 | 348  | 41604B01 | 306  | 41638-01 | 357  | 41671-11 | 100  | 41699C18 | 325  | 41739-20 | 265  | 41753D53 | 191  |
| 41589-25 | 348  | 41604C00 | 305  | 41638-02 | 356  | 41672-00 | 100  | 41699G18 | 325  | 41740-00 | 266  | 41753D60 | 191  |
| 41589-29 | 348  | 41604C01 | 306  | 41638-04 | 356  | 41673-00 | 100  | 41703-38 | 35   | 41743-32 | 191  | 41755-11 | 274  |
| 41589-37 | 348  | 41604G00 | 305  | 41638-12 | 356  | 41674-00 | 100  | 41704G33 | 22   | 41743-53 | 191  | 41756-30 | 190  |
| 41589-50 | 348  | 41604G01 | 306  | 41638-13 | 357  | 41675-00 | 100  | 41704G36 | 22   | 41743-60 | 191  | 41756-32 | 190  |

| Cod.     | pag. | Cod.     | pag. | Cod.     | pag. | Cod.     | pag. | Cod.     | pag. | Cod.     | pag. | Cod.     | pag. | Cod. | pag. |
|----------|------|----------|------|----------|------|----------|------|----------|------|----------|------|----------|------|------|------|
| 41756-53 | 190  | 41770-15 | 272  | 41877-81 | 417  | 41913-03 | 434  | 42400-30 | 439  | 42460-45 | 439  | 42505-27 | 161  |      |      |
| 41756-60 | 190  | 41771-96 | 272  | 41877-99 | 417  | 41913-04 | 434  | 42401-10 | 349  | 42460-53 | 436  | 42505-50 | 161  |      |      |
| 41758-53 | 247  | 41773-00 | 103  | 41878-45 | 417  | 41914-03 | 27   | 42401-15 | 349  | 42460-63 | 430  | 42506-08 | 161  |      |      |
| 41758-60 | 247  | 41774-33 | 268  | 41878-61 | 417  | 41916-10 | 110  | 42401-20 | 349  | 42460-64 | 430  | 42506-10 | 161  |      |      |
| 41758-65 | 247  | 41775-34 | 268  | 41878-81 | 417  | 41916-15 | 110  | 42401-AA | 527  | 42460-74 | 439  | 42506-12 | 161  |      |      |
| 41758-85 | 247  | 41780-05 | 261  | 41878-99 | 417  | 41916-20 | 110  | 42403-01 | 350  | 42460-76 | 439  | 42506-14 | 161  |      |      |
| 41759-01 | 246  | 41780-07 | 261  | 41879-30 | 417  | 41919-03 | 411  | 42403B01 | 350  | 42461-11 | 425  | 42506-16 | 161  |      |      |
| 41759-05 | 246  | 41780-09 | 261  | 41879-40 | 417  | 41922-16 | 110  | 42405-10 | 350  | 42461-35 | 425  | 42506-18 | 161  |      |      |
| 41759-09 | 246  | 41781-05 | 264  | 41879-50 | 417  | 41922-22 | 110  | 42405-20 | 350  | 42462-11 | 422  | 42507-12 | 160  |      |      |
| 41760-02 | 246  | 41781-10 | 264  | 41879-61 | 417  | 41925-14 | 111  | 42405-AA | 528  | 42462-12 | 422  | 42508-00 | 162  |      |      |
| 41760-05 | 246  | 41781-15 | 264  | 41880-38 | 417  | 41925-16 | 111  | 42406-35 | 439  | 42462-13 | 422  | 42508-01 | 162  |      |      |
| 41760-06 | 246  | 41782-04 | 319  | 41880-61 | 417  | 41925-18 | 111  | 42406-40 | 439  | 42462-14 | 422  | 42509-25 | 103  |      |      |
| 41760-08 | 247  | 41782-05 | 319  | 41881-30 | 417  | 41925-20 | 111  | 42407-03 | 350  | 42462-16 | 422  | 42509-50 | 103  |      |      |
| 41760-09 | 247  | 41782-06 | 319  | 41881-40 | 417  | 41925-22 | 111  | 42407-06 | 350  | 42462-23 | 422  | 42509-60 | 104  |      |      |
| 41760-20 | 246  | 41800-05 | 438  | 41882-15 | 417  | 41925-24 | 111  | 42408-03 | 350  | 42463-11 | 422  | 42509-99 | 104  |      |      |
| 41760-21 | 246  | 41800-10 | 438  | 41882-20 | 417  | 41925-26 | 111  | 42408-06 | 350  | 42463-12 | 422  | 42510-00 | 161  |      |      |
| 41760-22 | 245  | 41801-05 | 438  | 41882-25 | 417  | 41929-00 | 101  | 42408-08 | 350  | 42463-13 | 422  | 42511-20 | 160  |      |      |
| 41760-26 | 245  | 41806-00 | 437  | 41882-30 | 417  | 41929-02 | 101  | 42413-24 | 360  | 42463-14 | 422  | 42511-25 | 160  |      |      |
| 41760-27 | 245  | 41806-03 | 437  | 41885-30 | 417  | 41930-39 | 27   | 42414-05 | 360  | 42463-16 | 422  | 42511-30 | 160  |      |      |
| 41761-02 | 266  | 41807-12 | 438  | 41885-40 | 417  | 41931-08 | 112  | 42414-10 | 360  | 42463-23 | 422  | 42511-35 | 160  |      |      |
| 41762-07 | 271  | 41808-04 | 439  | 41885-45 | 417  | 41931-14 | 112  | 42414-15 | 360  | 42463A00 | 436  | 42511-40 | 160  |      |      |
| 41762-09 | 271  | 41809-09 | 454  | 41885-50 | 417  | 41931-16 | 112  | 42414-20 | 360  | 42463A02 | 420  | 42511-56 | 160  |      |      |
| 41762-13 | 271  | 41810-04 | 437  | 41885-60 | 417  | 41931-18 | 112  | 42417-22 | 360  | 42463A04 | 420  | 42511-60 | 160  |      |      |
| 41763-00 | 271  | 41810-09 | 438  | 41900-04 | 439  | 41932-05 | 112  | 42420-06 | 359  | 42463A05 | 420  | 42511-70 | 160  |      |      |
| 41763-30 | 472  | 41820-03 | 364  | 41900-10 | 439  | 41933-18 | 112  | 42420-08 | 359  | 42463A08 | 420  | 42512-35 | 104  |      |      |
| 41764-28 | 265  | 41860-36 | 480  | 41901-08 | 438  | 41940-06 | 429  | 42440-30 | 418  | 42463B00 | 436  | 42512-90 | 481  |      |      |
| 41764-33 | 265  | 41860-43 | 480  | 41901-16 | 438  | 41940B06 | 429  | 42441-25 | 418  | 42463B02 | 420  | 42512-91 | 481  |      |      |
| 41764-40 | 265  | 41860-47 | 480  | 41903A10 | 450  | 41941-43 | 429  | 42442-24 | 418  | 42463B04 | 420  | 42512-92 | 481  |      |      |
| 41765-32 | 264  | 41861-44 | 481  | 41903E10 | 450  | 41941-44 | 429  | 42443-06 | 366  | 42463B05 | 421  | 42512-93 | 481  |      |      |
| 41765-37 | 264  | 41862B11 | 481  | 41903U10 | 450  | 41944-06 | 428  | 42443-08 | 366  | 42463B08 | 421  | 42513-30 | 104  |      |      |
| 41765-41 | 264  | 41862B53 | 481  | 41904-10 | 439  | 41944B06 | 428  | 42445-03 | 367  | 42470-00 | 430  | 42513-45 | 104  |      |      |
| 41765-45 | 264  | 41862C11 | 481  | 41905-38 | 428  | 41945-38 | 428  | 42445-04 | 418  | 42470-06 | 430  | 42514-20 | 160  |      |      |
| 41765-50 | 264  | 41862C53 | 481  | 41906-60 | 429  | 41960-08 | 109  | 42445-05 | 418  | 42470-27 | 431  | 42515-18 | 160  |      |      |
| 41766-14 | 265  | 41862G11 | 481  | 41907-04 | 439  | 41960-10 | 109  | 42446-04 | 367  | 42470-43 | 436  | 42515-20 | 160  |      |      |
| 41766-16 | 265  | 41862G53 | 481  | 41907-06 | 439  | 41960-12 | 109  | 42450-00 | 429  | 42470-45 | 439  | 42516-18 | 160  |      |      |
| 41766-27 | 265  | 41870-01 | 414  | 41907-56 | 428  | 41960-15 | 109  | 42450-AD | 430  | 42470-53 | 436  | 42516-20 | 160  |      |      |
| 41767-20 | 265  | 41870-02 | 414  | 41908-00 | 435  | 41961-10 | 109  | 42451-11 | 430  | 42470-63 | 430  | 42517-06 | 160  |      |      |
| 41767-AA | 527  | 41870-03 | 414  | 41908-01 | 435  | 41961-12 | 109  | 42451-12 | 430  | 42470-64 | 430  | 42518-01 | 164  |      |      |
| 41767G20 | 22   | 41870-04 | 414  | 41909-08 | 438  | 41961-15 | 109  | 42452-14 | 431  | 42470-74 | 439  | 42518-50 | 165  |      |      |
| 41768-21 | 265  | 41875-40 | 417  | 41910-AL | 527  | 41962-10 | 109  | 42452-23 | 431  | 42470-76 | 439  | 42519-01 | 166  |      |      |
| 41768-22 | 265  | 41875-61 | 417  | 41911-02 | 435  | 41962-12 | 109  | 42452-35 | 425  | 42501-15 | 161  | 42520-00 | 166  |      |      |
| 41769-00 | 266  | 41876-30 | 417  | 41911-03 | 435  | 41962-15 | 109  | 42452-53 | 425  | 42501-20 | 161  | 42520-AA | 528  |      |      |
| 41769-01 | 266  | 41876-38 | 417  | 41911-04 | 436  | 41964-45 | 27   | 42453-23 | 431  | 42502-11 | 161  | 42521-16 | 164  |      |      |
| 41769-02 | 266  | 41876-45 | 417  | 41911-AA | 527  | 41964-60 | 27   | 42460-00 | 430  | 42503-10 | 161  | 42521-24 | 164  |      |      |
| 41769-36 | 266  | 41876-58 | 417  | 41911-AE | 527  | 41980-99 | 103  | 42460-06 | 430  | 42504-09 | 103  | 42522-00 | 164  |      |      |
| 41769-50 | 266  | 41877-45 | 417  | 41912-03 | 434  | 42400-19 | 439  | 42460-27 | 431  | 42505-21 | 161  | 42522-01 | 164  |      |      |
| 41769G00 | 266  | 41877-61 | 417  | 41912-04 | 434  | 42400-25 | 439  | 42460-43 | 437  | 42505-24 | 161  | 42522-02 | 164  |      |      |

**NUMERICAL INDEX INDICE NUMERICO NUMERISCH INDEX INDEX NUMERIQUE INDICE NUMERICO**

| Cod.     | pag. | Cod.     | pag. | Cod.     | pag. | Cod.     | pag. | Cod.     | pag. | Cod.     | pag. | Cod.     | pag. |
|----------|------|----------|------|----------|------|----------|------|----------|------|----------|------|----------|------|
| 42522-03 | 164  | 42538-02 | 22   | 42560-06 | 122  | 42577-93 | 528  | 42617-04 | 352  | 42666P27 | 376  | 42679P12 | 382  |
| 42522-04 | 164  | 42538-03 | 22   | 42560-07 | 122  | 42577-94 | 528  | 42617-05 | 352  | 42666P30 | 376  | 42679S12 | 382  |
| 42522-05 | 164  | 42538-04 | 22   | 42560-08 | 122  | 42577-99 | 528  | 42617-06 | 352  | 42666P40 | 376  | 42680-13 | 385  |
| 42522-07 | 22   | 42538-05 | 22   | 42560-09 | 122  | 42579-00 | 162  | 42617-07 | 352  | 42666S12 | 376  | 42681-16 | 385  |
| 42522-09 | 164  | 42538-07 | 22   | 42562-12 | 105  | 42581-01 | 105  | 42620P01 | 380  | 42666S18 | 376  | 42682P18 | 378  |
| 42522F09 | 522  | 42538-09 | 22   | 42562-14 | 105  | 42581-03 | 105  | 42620P02 | 380  | 42666S22 | 376  | 42682S18 | 378  |
| 42523-00 | 159  | 42538F09 | 522  | 42562-16 | 105  | 42581-05 | 105  | 42620P03 | 380  | 42666S27 | 376  | 42683P18 | 379  |
| 42524-06 | 161  | 42539-00 | 164  | 42562-18 | 105  | 42581-10 | 105  | 42623-10 | 100  | 42666S30 | 376  | 42683S18 | 379  |
| 42524-08 | 161  | 42539-01 | 164  | 42562-20 | 105  | 42581-15 | 105  | 42624P10 | 377  | 42666S40 | 376  | 42684P08 | 380  |
| 42524-10 | 161  | 42539-02 | 164  | 42562-25 | 105  | 42581-20 | 105  | 42624S10 | 377  | 42667P12 | 377  | 42684S08 | 380  |
| 42524-12 | 161  | 42539-03 | 164  | 42562-30 | 105  | 42584-01 | 357  | 42650-10 | 116  | 42667P18 | 377  | 42685-22 | 385  |
| 42524-14 | 161  | 42539-04 | 164  | 42563-00 | 118  | 42584-02 | 357  | 42650-11 | 116  | 42667P22 | 377  | 42685P14 | 379  |
| 42524-16 | 161  | 42539-05 | 164  | 42563-44 | 118  | 42584-04 | 357  | 42653-04 | 112  | 42667P30 | 377  | 42685S14 | 379  |
| 42524-18 | 161  | 42539-07 | 22   | 42565-00 | 118  | 42584-05 | 357  | 42655P15 | 379  | 42667S12 | 377  | 42687P18 | 374  |
| 42524-20 | 161  | 42539-09 | 164  | 42566-03 | 117  | 42584-06 | 357  | 42655S15 | 379  | 42667S18 | 377  | 42687P22 | 374  |
| 42524-22 | 161  | 42539F09 | 522  | 42569-04 | 123  | 42584-07 | 357  | 42660-02 | 384  | 42667S22 | 377  | 42687S18 | 374  |
| 42524-30 | 161  | 42540-40 | 165  | 42570-32 | 124  | 42585-00 | 468  | 42661-02 | 380  | 42667S30 | 377  | 42687S22 | 374  |
| 42525-27 | 161  | 42540-50 | 165  | 42570-91 | 528  | 42585-04 | 468  | 42661-03 | 380  | 42668P12 | 376  | 42688P18 | 374  |
| 42526-12 | 161  | 42540-80 | 165  | 42570-92 | 528  | 42585-06 | 468  | 42661-06 | 380  | 42668P18 | 376  | 42688P22 | 374  |
| 42526-14 | 161  | 42541-06 | 165  | 42570-94 | 528  | 42586-09 | 468  | 42662C14 | 383  | 42668P22 | 376  | 42688P30 | 374  |
| 42529-06 | 160  | 42542-00 | 166  | 42570-99 | 528  | 42586-10 | 468  | 42662P14 | 383  | 42668P30 | 376  | 42688S18 | 374  |
| 42530-26 | 162  | 42543-00 | 165  | 42571-20 | 124  | 42587-04 | 468  | 42662S14 | 383  | 42668P40 | 376  | 42688S22 | 374  |
| 42530-32 | 162  | 42543-01 | 165  | 42572-24 | 124  | 42588-00 | 115  | 42663C14 | 383  | 42668S12 | 376  | 42688S30 | 374  |
| 42530-41 | 162  | 42543-02 | 165  | 42573-31 | 124  | 42588-01 | 115  | 42663P14 | 383  | 42668S18 | 376  | 42689-15 | 383  |
| 42530-50 | 162  | 42543-03 | 165  | 42573-91 | 528  | 42589-00 | 117  | 42663S14 | 383  | 42668S22 | 376  | 42690-15 | 383  |
| 42531-26 | 162  | 42543-04 | 165  | 42573-92 | 528  | 42592-01 | 102  | 42664P12 | 377  | 42668S30 | 376  | 42701-10 | 377  |
| 42531-32 | 162  | 42543-05 | 165  | 42573-94 | 528  | 42592-02 | 102  | 42664P18 | 377  | 42669C14 | 383  | 42701P10 | 377  |
| 42531-41 | 162  | 42544-00 | 165  | 42573-99 | 528  | 42593-00 | 358  | 42664P22 | 377  | 42669P14 | 383  | 42702-10 | 378  |
| 42531-50 | 162  | 42544-01 | 165  | 42574-37 | 124  | 42595-01 | 115  | 42664P30 | 377  | 42669S14 | 383  | 42702P10 | 378  |
| 42532-29 | 162  | 42544-02 | 165  | 42574-90 | 528  | 42596-02 | 116  | 42664P40 | 377  | 42670B14 | 382  | 42703-10 | 377  |
| 42532-58 | 162  | 42544-03 | 165  | 42574-91 | 528  | 42597-00 | 115  | 42664S12 | 377  | 42670N14 | 382  | 42703S10 | 377  |
| 42533-23 | 199  | 42544-04 | 165  | 42574-92 | 528  | 42598-00 | 116  | 42664S18 | 377  | 42670W14 | 382  | 42704-10 | 378  |
| 42533-26 | 199  | 42544-05 | 165  | 42574-93 | 528  | 42599-06 | 117  | 42664S22 | 377  | 42674P18 | 377  | 42704S10 | 378  |
| 42533-31 | 199  | 42546-00 | 164  | 42574-94 | 528  | 42599-08 | 117  | 42664S30 | 377  | 42674P22 | 377  | 42705M15 | 384  |
| 42533-36 | 199  | 42546-01 | 164  | 42574-99 | 528  | 42607-05 | 199  | 42665P12 | 374  | 42674P30 | 377  | 42705P10 | 378  |
| 42533-40 | 199  | 42546-02 | 164  | 42575-37 | 124  | 42609-10 | 107  | 42665P18 | 374  | 42674S18 | 377  | 42705P16 | 381  |
| 42534-26 | 162  | 42546-03 | 164  | 42575-90 | 528  | 42609-15 | 107  | 42665P22 | 374  | 42674S22 | 377  | 42705P21 | 381  |
| 42534-32 | 162  | 42546-04 | 164  | 42575-91 | 528  | 42609-20 | 107  | 42665P30 | 374  | 42674S30 | 377  | 42705S10 | 378  |
| 42534-41 | 162  | 42546-05 | 164  | 42575-92 | 528  | 42609-23 | 107  | 42665P40 | 374  | 42676P15 | 379  | 42705S16 | 381  |
| 42535-24 | 165  | 42555-11 | 261  | 42575-93 | 528  | 42609-25 | 107  | 42665S12 | 374  | 42676P20 | 379  | 42705S21 | 381  |
| 42535-32 | 165  | 42556-00 | 123  | 42575-94 | 528  | 42614-04 | 248  | 42665S18 | 374  | 42676S15 | 379  | 42707P21 | 378  |
| 42535-49 | 165  | 42558-00 | 124  | 42575-99 | 528  | 42614-05 | 248  | 42665S22 | 374  | 42676S20 | 379  | 42707S21 | 378  |
| 42537-40 | 164  | 42560-01 | 122  | 42576-00 | 124  | 42614-06 | 248  | 42665S30 | 374  | 42677P14 | 379  | 42710-11 | 380  |
| 42537-50 | 164  | 42560-02 | 122  | 42577-39 | 124  | 42614-07 | 248  | 42665S40 | 374  | 42677S14 | 379  | 42713P10 | 378  |
| 42537-80 | 164  | 42560-03 | 122  | 42577-90 | 528  | 42614-21 | 199  | 42666P12 | 376  | 42678P14 | 382  | 42713S10 | 378  |
| 42538-00 | 22   | 42560-04 | 122  | 42577-91 | 528  | 42615-04 | 105  | 42666P18 | 376  | 42678S14 | 382  | 42714P10 | 378  |
| 42538-01 | 22   | 42560-05 | 122  | 42577-92 | 528  | 42616-04 | 105  | 42666P22 | 376  | 42678W14 | 382  | 42714S10 | 378  |



| Cod.     | pag. | Cod.     | pag. | Cod.     | pag. | Cod.     | pag. | Cod.     | pag. | Cod.     | pag. | Cod.     | pag. | Cod. | pag. | Cod. | pag. |
|----------|------|----------|------|----------|------|----------|------|----------|------|----------|------|----------|------|------|------|------|------|
| 42717P16 | 381  | 42749P22 | 374  | 42873-02 | 427  | 42907-08 | 101  | 42950-02 | 341  | 42967-17 | 423  | 42990-29 | 426  |      |      |      |      |
| 42717S16 | 381  | 42749S18 | 374  | 42874-01 | 420  | 42907-09 | 101  | 42950-03 | 341  | 42967-18 | 423  | 42990M16 | 426  |      |      |      |      |
| 42718P18 | 376  | 42749S22 | 374  | 42874-02 | 420  | 42907-10 | 101  | 42950-04 | 341  | 42967-35 | 423  | 42990M20 | 426  |      |      |      |      |
| 42718P22 | 376  | 42764M15 | 384  | 42874-03 | 420  | 42907-30 | 101  | 42950-05 | 341  | 42967-43 | 424  | 42990M29 | 426  |      |      |      |      |
| 42718S18 | 376  | 42764P16 | 380  | 42874-04 | 420  | 42907-35 | 101  | 42950-06 | 341  | 42967-53 | 424  | 42990N16 | 426  |      |      |      |      |
| 42718S22 | 376  | 42764P21 | 380  | 42875-17 | 354  | 42907-40 | 101  | 42950-07 | 341  | 42967-63 | 422  | 42990N20 | 426  |      |      |      |      |
| 42720-01 | 384  | 42764S16 | 380  | 42875-20 | 354  | 42908-24 | 112  | 42950-08 | 341  | 42967-64 | 422  | 42990N29 | 426  |      |      |      |      |
| 42721P18 | 377  | 42764S21 | 380  | 42875B17 | 354  | 42920-02 | 277  | 42950-09 | 341  | 42967-65 | 422  | 42991-25 | 425  |      |      |      |      |
| 42721P22 | 377  | 42767P12 | 379  | 42875B20 | 354  | 42921-00 | 357  | 42950-92 | 341  | 42967-66 | 422  | 42991-32 | 425  |      |      |      |      |
| 42721P30 | 377  | 42767P15 | 379  | 42876-20 | 354  | 42923-07 | 277  | 42950-93 | 341  | 42967-67 | 422  | 42991M25 | 425  |      |      |      |      |
| 42721S18 | 377  | 42767P20 | 379  | 42876-25 | 354  | 42924-02 | 355  | 42950-94 | 341  | 42967-68 | 422  | 42991M32 | 425  |      |      |      |      |
| 42721S22 | 377  | 42767S12 | 379  | 42876B20 | 354  | 42926-12 | 355  | 42951-08 | 367  | 42967-73 | 422  | 42991N25 | 425  |      |      |      |      |
| 42721S30 | 377  | 42767S15 | 379  | 42876B25 | 354  | 42927-02 | 355  | 42951-57 | 367  | 42967-74 | 422  | 42991N32 | 425  |      |      |      |      |
| 42723P10 | 384  | 42767S20 | 379  | 42877-17 | 353  | 42928-00 | 355  | 42951-59 | 367  | 42967-75 | 422  | 42993-40 | 426  |      |      |      |      |
| 42723S10 | 384  | 42785S20 | 384  | 42877-25 | 353  | 42929-01 | 355  | 42952-05 | 367  | 42967-76 | 422  | 42993M40 | 426  |      |      |      |      |
| 42725P10 | 384  | 42786S20 | 384  | 42878-17 | 353  | 42929-02 | 356  | 42953-04 | 358  | 42967-77 | 422  | 42993N40 | 426  |      |      |      |      |
| 42725S10 | 384  | 42796P16 | 381  | 42878-25 | 353  | 42929-03 | 356  | 42954-04 | 367  | 42967-78 | 422  | 44009-00 | 469  |      |      |      |      |
| 42727-09 | 381  | 42796P23 | 381  | 42879K12 | 353  | 42929-AA | 529  | 42954-18 | 367  | 42968-38 | 423  | 44020-21 | 469  |      |      |      |      |
| 42727-12 | 381  | 42796S16 | 381  | 42879K15 | 353  | 42929-AB | 529  | 42954-29 | 367  | 42968-42 | 424  | 44023-00 | 468  |      |      |      |      |
| 42727-18 | 381  | 42796S23 | 381  | 42879K22 | 353  | 42929-AC | 529  | 42954-46 | 367  | 42969-11 | 424  | 44023-AA | 529  |      |      |      |      |
| 42727-22 | 381  | 42798P11 | 381  | 42879K25 | 353  | 42931-19 | 355  | 42955-00 | 358  | 42969-31 | 424  | 44024-00 | 468  |      |      |      |      |
| 42727-30 | 381  | 42798S11 | 381  | 42879M12 | 353  | 42935-19 | 354  | 42956-19 | 312  | 42969-36 | 424  | 44025-50 | 469  |      |      |      |      |
| 42727-38 | 381  | 42801P14 | 384  | 42879M15 | 353  | 42935-26 | 354  | 42956-24 | 312  | 42972-01 | 424  | 44026-60 | 486  |      |      |      |      |
| 42728-09 | 381  | 42801S14 | 384  | 42879M22 | 353  | 42936-23 | 424  | 42956-28 | 312  | 42972-02 | 424  | 44027-00 | 469  |      |      |      |      |
| 42728-12 | 381  | 42822-00 | 267  | 42879M25 | 353  | 42936-24 | 424  | 42959-12 | 361  | 42972-03 | 424  | 44027-AA | 529  |      |      |      |      |
| 42728-18 | 381  | 42826-32 | 267  | 42900-15 | 101  | 42936-28 | 424  | 42959-13 | 361  | 42972-04 | 424  | 44028-19 | 472  |      |      |      |      |
| 42728-22 | 381  | 42826-37 | 267  | 42900-24 | 101  | 42939-15 | 366  | 42962-04 | 433  | 42972-28 | 423  | 44029-00 | 469  |      |      |      |      |
| 42728-30 | 381  | 42854B25 | 102  | 42901-20 | 101  | 42939-AA | 529  | 42962-26 | 279  | 42973-30 | 423  | 44030-03 | 482  |      |      |      |      |
| 42728-38 | 381  | 42854B30 | 102  | 42901-25 | 101  | 42940-03 | 415  | 42962-30 | 433  | 42973-45 | 423  | 44031-01 | 483  |      |      |      |      |
| 42728S18 | 381  | 42854C25 | 102  | 42901-30 | 101  | 42941-22 | 366  | 42962-44 | 433  | 42973-60 | 423  | 44031-02 | 483  |      |      |      |      |
| 42741-22 | 378  | 42854C30 | 102  | 42901-35 | 101  | 42941-AA | 529  | 42962C26 | 279  | 42973-61 | 423  | 44031-04 | 469  |      |      |      |      |
| 42742-22 | 378  | 42854G25 | 103  | 42901-40 | 101  | 42942-16 | 365  | 42962C44 | 433  | 42974B13 | 354  | 44031-05 | 469  |      |      |      |      |
| 42746P12 | 375  | 42854G30 | 103  | 42902-30 | 102  | 42944-23 | 354  | 42963-55 | 422  | 42974C13 | 354  | 44033-23 | 473  |      |      |      |      |
| 42746P18 | 375  | 42854K25 | 103  | 42902-31 | 102  | 42945-18 | 354  | 42964-53 | 166  | 42974M13 | 354  | 44033-38 | 473  |      |      |      |      |
| 42746P22 | 375  | 42854K30 | 103  | 42902B30 | 304  | 42945-23 | 354  | 42964-60 | 166  | 42974N13 | 354  | 44034-11 | 473  |      |      |      |      |
| 42746P30 | 375  | 42854R25 | 103  | 42902C30 | 304  | 42945-27 | 354  | 42965-12 | 424  | 42979-00 | 415  | 44040-40 | 470  |      |      |      |      |
| 42746P40 | 375  | 42854R30 | 103  | 42902G30 | 304  | 42946-23 | 424  | 42967-03 | 423  | 42979-36 | 415  | 44041-00 | 470  |      |      |      |      |
| 42746P50 | 375  | 42854Y25 | 103  | 42903-29 | 103  | 42946-37 | 424  | 42967-04 | 423  | 42979-45 | 415  | 44041-01 | 470  |      |      |      |      |
| 42746P80 | 375  | 42854Y30 | 103  | 42904-01 | 102  | 42947-23 | 424  | 42967-05 | 423  | 42980-01 | 415  | 44041-03 | 470  |      |      |      |      |
| 42746S18 | 375  | 42862-00 | 102  | 42904-02 | 102  | 42947-30 | 424  | 42967-06 | 423  | 42980-02 | 416  | 44041-04 | 470  |      |      |      |      |
| 42746S22 | 375  | 42863-00 | 102  | 42904-03 | 102  | 42947-40 | 424  | 42967-07 | 423  | 42981-73 | 415  | 44041-05 | 470  |      |      |      |      |
| 42746S30 | 375  | 42864-10 | 163  | 42907-01 | 101  | 42948-18 | 354  | 42967-08 | 423  | 42982-08 | 41   | 44042-00 | 470  |      |      |      |      |
| 42747P12 | 375  | 42870-50 | 422  | 42907-02 | 101  | 42948-20 | 354  | 42967-11 | 425  | 42988-99 | 405  | 44043-00 | 470  |      |      |      |      |
| 42747P18 | 375  | 42870-51 | 422  | 42907-03 | 101  | 42948-23 | 354  | 42967-13 | 423  | 42988C99 | 405  | 44044-00 | 470  |      |      |      |      |
| 42747S12 | 375  | 42870-59 | 426  | 42907-04 | 101  | 42948-25 | 354  | 42967-14 | 423  | 42988G99 | 405  | 44047-17 | 469  |      |      |      |      |
| 42747S18 | 375  | 42872-02 | 426  | 42907-06 | 101  | 42949-26 | 427  | 42967-15 | 423  | 42990-16 | 426  | 44047-19 | 469  |      |      |      |      |
| 42749P18 | 374  | 42873-01 | 354  | 42907-07 | 101  | 42950-01 | 341  | 42967-16 | 423  | 42990-20 | 426  | 44047-22 | 469  |      |      |      |      |

**NUMERICAL INDEX INDICE NUMERICO NUMERISCH INDEX INDEX NUMERIQUE INDICE NUMERICO**

| Cod.     | pag. | Cod.     | pag. | Cod.     | pag. | Cod.     | pag. | Cod.     | pag. | Cod.     | pag. | Cod.     | pag. |
|----------|------|----------|------|----------|------|----------|------|----------|------|----------|------|----------|------|
| 44047-25 | 469  | 44094-03 | 464  | 44106R10 | 318  | 44114-01 | 323  | 44170-00 | 488  | 44201R24 | 44   | 44234-12 | 47   |
| 44047-28 | 469  | 44094-04 | 464  | 44106R20 | 318  | 44114-02 | 323  | 44170-01 | 488  | 44201R28 | 44   | 44234-16 | 47   |
| 44048-99 | 326  | 44094-05 | 464  | 44106R25 | 318  | 44114-03 | 323  | 44171-24 | 490  | 44201R32 | 44   | 44234S16 | 47   |
| 44055-10 | 322  | 44094-06 | 464  | 44106W05 | 317  | 44118-10 | 323  | 44171-50 | 490  | 44201V10 | 44   | 44237S15 | 48   |
| 44055-20 | 322  | 44094R00 | 463  | 44106W10 | 317  | 44118-20 | 323  | 44172-30 | 490  | 44201V12 | 44   | 44240-08 | 48   |
| 44055-25 | 322  | 44094-RE | 529  | 44106W20 | 317  | 44118-25 | 323  | 44173-00 | 490  | 44202-10 | 44   | 44240S08 | 44   |
| 44055-30 | 322  | 44095-12 | 492  | 44106W25 | 317  | 44118-30 | 323  | 44174-24 | 487  | 44202N12 | 44   | 44241-19 | 48   |
| 44055-35 | 322  | 44095-18 | 492  | 44106Y05 | 317  | 44118-35 | 323  | 44174-AA | 530  | 44202N25 | 45   | 44242-00 | 48   |
| 44055-40 | 322  | 44095-30 | 483  | 44106Y10 | 317  | 44118-40 | 323  | 44175-15 | 487  | 44202N29 | 45   | 44243-00 | 48   |
| 44055-50 | 322  | 44095-32 | 483  | 44106Y20 | 317  | 44118-50 | 323  | 44176-30 | 487  | 44202R12 | 44   | 44244S36 | 48   |
| 44055C30 | 322  | 44096-80 | 492  | 44106Y25 | 317  | 44119-01 | 323  | 44177-12 | 487  | 44202R29 | 45   | 44245S32 | 48   |
| 44055C40 | 322  | 44096B80 | 492  | 44107B05 | 318  | 44119-02 | 323  | 44178-01 | 486  | 44204R24 | 45   | 44246S14 | 48   |
| 44055G30 | 322  | 44096G80 | 492  | 44107B10 | 318  | 44119-03 | 323  | 44178-02 | 486  | 44204R28 | 45   | 44246S17 | 48   |
| 44055G40 | 322  | 44096R80 | 492  | 44107B20 | 318  | 44119-04 | 323  | 44178-15 | 486  | 44207-20 | 44   | 44247S16 | 48   |
| 44056-01 | 322  | 44096Y80 | 492  | 44107B25 | 318  | 44119-06 | 323  | 44178-16 | 486  | 44208G00 | 44   | 44248S60 | 334  |
| 44056-04 | 321  | 44097-00 | 490  | 44107G05 | 318  | 44130-01 | 321  | 44178-17 | 487  | 44208R00 | 44   | 44250S30 | 334  |
| 44056-06 | 321  | 44099-03 | 319  | 44107G10 | 318  | 44130-02 | 321  | 44178-18 | 487  | 44209R26 | 45   | 44254-30 | 334  |
| 44056-11 | 322  | 44100-01 | 319  | 44107G20 | 318  | 44130-03 | 321  | 44178-19 | 487  | 44209R32 | 45   | 44256-02 | 334  |
| 44056-21 | 322  | 44100-02 | 319  | 44107G25 | 318  | 44135-02 | 321  | 44178-20 | 487  | 44210-26 | 45   | 44256-03 | 334  |
| 44057-04 | 321  | 44100-04 | 319  | 44107O05 | 318  | 44141-01 | 488  | 44183-01 | 494  | 44210-32 | 45   | 44256-04 | 334  |
| 44057-06 | 321  | 44101-03 | 319  | 44107O10 | 318  | 44141-03 | 488  | 44183-A3 | 494  | 44210-42 | 45   | 44258-60 | 334  |
| 44058-10 | 322  | 44101-AA | 529  | 44107O20 | 318  | 44142-40 | 489  | 44183-A4 | 494  | 44210S32 | 45   | 44264-35 | 334  |
| 44058-20 | 322  | 44102-24 | 315  | 44107O25 | 318  | 44147-00 | 489  | 44184-01 | 494  | 44212-30 | 46   | 44265-35 | 334  |
| 44058-25 | 322  | 44103-03 | 319  | 44107R05 | 318  | 44147-01 | 489  | 44184-A3 | 494  | 44213-24 | 45   | 44312A06 | 77   |
| 44058-30 | 322  | 44103-04 | 319  | 44107R10 | 318  | 44147-02 | 489  | 44184-A4 | 494  | 44213-36 | 45   | 44312B06 | 77   |
| 44058-40 | 322  | 44103-06 | 319  | 44107R20 | 318  | 44147-03 | 489  | 44185-50 | 368  | 44214-25 | 46   | 44312G06 | 77   |
| 44058-50 | 322  | 44103-AA | 530  | 44107R25 | 318  | 44148-01 | 488  | 44185-70 | 368  | 44215S16 | 47   | 44312O06 | 77   |
| 44060-01 | 321  | 44103-AB | 530  | 44107W05 | 318  | 44149-03 | 488  | 44187-40 | 368  | 44216S16 | 46   | 44312R06 | 77   |
| 44060-02 | 321  | 44103-AC | 530  | 44107W10 | 318  | 44150-19 | 488  | 44187-60 | 368  | 44217-45 | 46   | 44312Y06 | 77   |
| 44060-50 | 103  | 44104-01 | 278  | 44107W20 | 318  | 44151-00 | 488  | 44201-01 | 44   | 44218R30 | 45   | 44313B06 | 77   |
| 44060-51 | 321  | 44104-02 | 278  | 44107W25 | 318  | 44151-AA | 488  | 44201-03 | 44   | 44218R40 | 45   | 44313G06 | 77   |
| 44060-80 | 103  | 44104-15 | 278  | 44107Y05 | 318  | 44151-AB | 488  | 44201-10 | 44   | 44219R26 | 45   | 44313O06 | 77   |
| 44060-99 | 321  | 44105-00 | 313  | 44107Y10 | 318  | 44151-AC | 488  | 44201B10 | 44   | 44220-AA | 530  | 44313R06 | 77   |
| 44061-08 | 103  | 44106-12 | 319  | 44107Y20 | 318  | 44160-03 | 488  | 44201B12 | 44   | 44220S24 | 47   | 44313Y06 | 77   |
| 44061-09 | 103  | 44106B05 | 318  | 44107Y25 | 318  | 44160-AA | 530  | 44201N10 | 44   | 44221S30 | 47   | 44314A06 | 77   |
| 44061-12 | 103  | 44106B10 | 318  | 44108-01 | 315  | 44161-00 | 489  | 44201N12 | 44   | 44222S20 | 47   | 44314B06 | 77   |
| 44061-14 | 103  | 44106B20 | 318  | 44108-02 | 315  | 44164-00 | 489  | 44201N16 | 45   | 44222S28 | 47   | 44314G06 | 77   |
| 44077-00 | 489  | 44106B25 | 318  | 44110-00 | 323  | 44165-35 | 489  | 44201N20 | 45   | 44224-22 | 46   | 44314O06 | 77   |
| 44077-06 | 489  | 44106G05 | 317  | 44110-01 | 322  | 44165-40 | 489  | 44201N24 | 45   | 44224S22 | 46   | 44314R06 | 77   |
| 44077-10 | 490  | 44106G10 | 317  | 44110-02 | 322  | 44165-50 | 489  | 44201N28 | 45   | 44225-22 | 46   | 44314Y06 | 77   |
| 44077-CC | 489  | 44106G20 | 317  | 44110-03 | 322  | 44166-28 | 489  | 44201N32 | 45   | 44226S30 | 46   | 44315A06 | 77   |
| 44089-12 | 492  | 44106G25 | 317  | 44110-04 | 322  | 44167-13 | 489  | 44201O10 | 44   | 44227-30 | 46   | 44315B06 | 77   |
| 44093-00 | 418  | 44106O05 | 318  | 44110-05 | 322  | 44168-12 | 490  | 44201O12 | 44   | 44228S23 | 47   | 44315G06 | 77   |
| 44093-01 | 418  | 44106O10 | 318  | 44110-06 | 322  | 44169B06 | 490  | 44201R10 | 44   | 44230S14 | 47   | 44315O06 | 77   |
| 44094-00 | 463  | 44106O20 | 318  | 44111-02 | 322  | 44169B14 | 490  | 44201R12 | 44   | 44232S16 | 47   | 44315R06 | 77   |
| 44094-01 | 463  | 44106O25 | 318  | 44112-01 | 323  | 44169R06 | 490  | 44201R16 | 44   | 44232S20 | 47   | 44315Y06 | 77   |
| 44094-02 | 463  | 44106R05 | 318  | 44112-02 | 323  | 44169R25 | 490  | 44201R20 | 44   | 44233-20 | 47   | 44317A06 | 77   |

| Cod.     | pag. | Cod.     | pag. | Cod.     | pag. | Cod.     | pag. | Cod.     | pag. | Cod.     | pag. | Cod.     | pag. |
|----------|------|----------|------|----------|------|----------|------|----------|------|----------|------|----------|------|
| 44317B06 | 77   | 44371-44 | 50   | 44394-21 | 50   | 44456B14 | 250  | 44473-33 | 331  | 44477-79 | 410  | 44480-18 | 345  |
| 44317G06 | 77   | 44371-48 | 50   | 44395-18 | 50   | 44457-32 | 250  | 44473-34 | 331  | 44477-80 | 410  | 44480-19 | 344  |
| 44317O06 | 77   | 44372-26 | 50   | 44397-18 | 50   | 44457B32 | 250  | 44474-09 | 282  | 44477-81 | 410  | 44480-20 | 344  |
| 44317R06 | 77   | 44372-32 | 50   | 44412-00 | 60   | 44459-28 | 251  | 44474-13 | 282  | 44478-20 | 345  | 44501-01 | 28   |
| 44317Y06 | 77   | 44372-36 | 50   | 44421-00 | 60   | 44459B28 | 251  | 44474-24 | 282  | 44478-21 | 345  | 44501-02 | 28   |
| 44322-02 | 60   | 44372-40 | 50   | 44422-00 | 60   | 44461-20 | 251  | 44474-25 | 282  | 44478-22 | 345  | 44501-03 | 28   |
| 44322-04 | 60   | 44374-22 | 50   | 44423-00 | 60   | 44461B20 | 251  | 44474-33 | 282  | 44478-23 | 346  | 44501-04 | 28   |
| 44322-06 | 60   | 44374-25 | 50   | 44430-60 | 190  | 44462-25 | 251  | 44474-34 | 282  | 44478-24 | 346  | 44502-01 | 28   |
| 44332-03 | 74   | 44374-32 | 50   | 44430-61 | 190  | 44462B25 | 251  | 44474-38 | 282  | 44478-25 | 346  | 44502-02 | 28   |
| 44332-06 | 74   | 44374-36 | 50   | 44431-46 | 190  | 44463-11 | 250  | 44474-39 | 282  | 44478-26 | 346  | 44502-03 | 28   |
| 44332B06 | 74   | 44374-40 | 50   | 44431-60 | 190  | 44464-23 | 250  | 44475-80 | 283  | 44478-27 | 346  | 44502-04 | 28   |
| 44333-03 | 75   | 44374-44 | 50   | 44432-21 | 60   | 44465-24 | 250  | 44475-81 | 283  | 44478-28 | 346  | 44503-01 | 28   |
| 44333-06 | 75   | 44375-25 | 50   | 44446-10 | 407  | 44466-07 | 291  | 44475-82 | 283  | 44478-29 | 346  | 44503-02 | 28   |
| 44333B06 | 75   | 44376-40 | 50   | 44446-14 | 407  | 44466-11 | 335  | 44475-83 | 283  | 44478-30 | 346  | 44503-03 | 28   |
| 44334-03 | 75   | 44379-05 | 353  | 44446-18 | 407  | 44466-12 | 335  | 44476-20 | 413  | 44478-31 | 346  | 44503-04 | 28   |
| 44334-06 | 75   | 44382A06 | 74   | 44446B10 | 407  | 44466-13 | 335  | 44476-26 | 413  | 44478-32 | 346  | 44505-10 | 478  |
| 44335-03 | 75   | 44382B06 | 74   | 44446B14 | 407  | 44466-14 | 335  | 44476-27 | 413  | 44478-33 | 346  | 44505-15 | 478  |
| 44335-06 | 75   | 44382G06 | 74   | 44446B18 | 407  | 44466-15 | 335  | 44476-28 | 413  | 44478-34 | 346  | 44505-20 | 478  |
| 44335B06 | 75   | 44382O06 | 74   | 44449-30 | 407  | 44466-16 | 404  | 44476-29 | 413  | 44478-35 | 346  | 44505-25 | 478  |
| 44337-03 | 75   | 44382Y06 | 74   | 44449-32 | 407  | 44466-30 | 291  | 44476-30 | 413  | 44478-70 | 412  | 44506-09 | 478  |
| 44337-06 | 75   | 44383O06 | 75   | 44449B30 | 407  | 44470-03 | 408  | 44476-31 | 413  | 44478-71 | 412  | 44511-27 | 474  |
| 44337B06 | 75   | 44383Y06 | 75   | 44449B32 | 407  | 44470-04 | 408  | 44476-32 | 413  | 44478-72 | 412  | 44511-34 | 474  |
| 44338-03 | 75   | 44384A06 | 75   | 44450-11 | 251  | 44470-11 | 408  | 44476-33 | 413  | 44478-73 | 412  | 44511-38 | 474  |
| 44338-06 | 75   | 44384O06 | 75   | 44450-12 | 251  | 44470-12 | 408  | 44476-51 | 413  | 44478-74 | 412  | 44511-42 | 474  |
| 44339-03 | 75   | 44384R06 | 75   | 44450-13 | 251  | 44470-13 | 408  | 44476-52 | 413  | 44478-75 | 412  | 44511-63 | 474  |
| 44339-06 | 75   | 44384Y06 | 75   | 44450-15 | 251  | 44470-14 | 408  | 44476-53 | 413  | 44478-76 | 412  | 44511-90 | 474  |
| 44342-06 | 77   | 44385A06 | 75   | 44450-17 | 251  | 44470-22 | 409  | 44477-24 | 410  | 44478-77 | 411  | 44511E21 | 473  |
| 44343-06 | 77   | 44385B06 | 75   | 44450-21 | 251  | 44470-24 | 409  | 44477-25 | 410  | 44478-78 | 411  | 44511E63 | 473  |
| 44344-06 | 77   | 44385G06 | 75   | 44450-23 | 251  | 44470-30 | 408  | 44477-26 | 410  | 44478-79 | 411  | 44511E90 | 473  |
| 44345-06 | 77   | 44385O06 | 75   | 44450B11 | 251  | 44470-31 | 409  | 44477-27 | 410  | 44478-80 | 411  | 44512000 | 473  |
| 44346-06 | 77   | 44385R06 | 75   | 44450B12 | 251  | 44470-38 | 409  | 44477-28 | 410  | 44480-00 | 345  | 44512-34 | 474  |
| 44347-06 | 77   | 44385Y06 | 75   | 44450B13 | 251  | 44470-40 | 408  | 44477-40 | 410  | 44480-01 | 345  | 44512-42 | 474  |
| 44352-30 | 454  | 44387A06 | 75   | 44450B15 | 251  | 44470-73 | 408  | 44477-41 | 410  | 44480-03 | 344  | 44512-63 | 474  |
| 44352-40 | 454  | 44387B06 | 75   | 44450B17 | 251  | 44470-74 | 408  | 44477-44 | 410  | 44480-04 | 345  | 44512-90 | 474  |
| 44355-30 | 454  | 44387G06 | 75   | 44450B21 | 251  | 44470-75 | 408  | 44477-52 | 410  | 44480-05 | 345  | 44512E12 | 473  |
| 44355-40 | 454  | 44387O06 | 75   | 44450B23 | 251  | 44471-11 | 331  | 44477-53 | 410  | 44480-06 | 344  | 44512E21 | 473  |
| 44357-07 | 252  | 44387R06 | 75   | 44451-22 | 251  | 44471-12 | 331  | 44477-54 | 410  | 44480-07 | 344  | 44513000 | 473  |
| 44357-10 | 353  | 44387Y06 | 75   | 44451B22 | 251  | 44471-13 | 331  | 44477-55 | 410  | 44480-08 | 344  | 44513-34 | 474  |
| 44357-15 | 353  | 44389-32 | 50   | 44452-31 | 250  | 44471-14 | 331  | 44477-64 | 410  | 44480-09 | 344  | 44513-38 | 474  |
| 44357B10 | 353  | 44390-07 | 50   | 44452B31 | 250  | 44471-24 | 331  | 44477-65 | 410  | 44480-10 | 344  | 44513-54 | 474  |
| 44357B15 | 353  | 44390-09 | 50   | 44453-14 | 250  | 44473-02 | 268  | 44477-66 | 410  | 44480-11 | 344  | 44513-63 | 474  |
| 44366-10 | 369  | 44390-11 | 50   | 44453B14 | 250  | 44473-03 | 268  | 44477-67 | 410  | 44480-12 | 344  | 44513-90 | 474  |
| 44371-24 | 50   | 44390-15 | 50   | 44454-11 | 250  | 44473-05 | 331  | 44477-68 | 410  | 44480-13 | 344  | 44513E12 | 473  |
| 44371-28 | 50   | 44390-18 | 50   | 44454B11 | 250  | 44473-07 | 331  | 44477-69 | 410  | 44480-14 | 344  | 44513E21 | 473  |
| 44371-32 | 50   | 44390-23 | 50   | 44455-09 | 250  | 44473-08 | 331  | 44477-76 | 410  | 44480-15 | 344  | 44521000 | 474  |
| 44371-36 | 50   | 44391-12 | 50   | 44455B09 | 250  | 44473-31 | 331  | 44477-77 | 410  | 44480-16 | 344  | 44521-16 | 474  |
| 44371-40 | 50   | 44394-18 | 50   | 44456-14 | 250  | 44473-32 | 331  | 44477-78 | 410  | 44480-17 | 345  | 44521-21 | 474  |

**NUMERICAL INDEX INDICE NUMERICO NUMERISCH INDEX INDEX NUMERIQUE INDICE NUMERICO**

| Cod.     | pag. | Cod.     | pag. | Cod.     | pag. | Cod.     | pag. | Cod.     | pag. | Cod.     | pag. | Cod.     | pag. |
|----------|------|----------|------|----------|------|----------|------|----------|------|----------|------|----------|------|
| 44521-31 | 474  | 44701T32 | 389  | 44807-28 | 481  | 44840-02 | 402  | 44843B24 | 404  | 44871-32 | 310  | 44884-19 | 432  |
| 44521E10 | 474  | 44701T40 | 389  | 44807-36 | 481  | 44840-03 | 402  | 44844-01 | 403  | 44871-33 | 311  | 44884-25 | 432  |
| 44522000 | 474  | 44702B21 | 389  | 44818-11 | 73   | 44840-04 | 402  | 44844-11 | 403  | 44871-34 | 310  | 44884B12 | 432  |
| 44522-16 | 474  | 44702B28 | 389  | 44818-12 | 73   | 44840-05 | 402  | 44844B01 | 403  | 44871-35 | 311  | 44884B19 | 432  |
| 44522-21 | 474  | 44702B36 | 389  | 44818-13 | 73   | 44840-06 | 432  | 44845-21 | 281  | 44871B20 | 310  | 44884B25 | 432  |
| 44522-31 | 474  | 44702C21 | 389  | 44818-14 | 73   | 44840-07 | 432  | 44845-30 | 404  | 44871B21 | 310  | 44885-19 | 432  |
| 44522E10 | 474  | 44702C28 | 389  | 44818-16 | 73   | 44840-08 | 413  | 44845-31 | 281  | 44871G20 | 310  | 44885-25 | 432  |
| 44620-01 | 471  | 44702C36 | 389  | 44819-02 | 483  | 44840-10 | 413  | 44845-38 | 280  | 44871G21 | 310  | 44888-32 | 409  |
| 44620-02 | 471  | 44702M21 | 390  | 44819-03 | 482  | 44840-18 | 413  | 44845-39 | 281  | 44871L20 | 310  | 44888-35 | 409  |
| 44620-03 | 471  | 44702M28 | 390  | 44820-80 | 482  | 44840-27 | 349  | 44845-41 | 404  | 44871L21 | 310  | 44888-40 | 409  |
| 44620-04 | 471  | 44702M36 | 390  | 44820-99 | 482  | 44840-28 | 349  | 44845-51 | 404  | 44871R20 | 310  | 44889-32 | 409  |
| 44620-05 | 471  | 44702R21 | 390  | 44822-80 | 482  | 44840-30 | 412  | 44846-05 | 403  | 44871R21 | 310  | 44889-35 | 409  |
| 44620-06 | 471  | 44702R28 | 390  | 44822-99 | 482  | 44840-31 | 412  | 44846-09 | 403  | 44873-06 | 281  | 44889-40 | 409  |
| 44620-07 | 471  | 44702R36 | 390  | 44825-20 | 483  | 44840-32 | 412  | 44846-13 | 403  | 44873-08 | 281  | 44930-10 | 478  |
| 44620-14 | 471  | 44702S21 | 390  | 44825-40 | 483  | 44840-40 | 412  | 44846-15 | 403  | 44873-10 | 281  | 44930-20 | 478  |
| 44620-17 | 471  | 44702S28 | 390  | 44826-00 | 482  | 44840-41 | 412  | 44846B05 | 335  | 44873-15 | 281  | 44932-15 | 478  |
| 44625-03 | 471  | 44702S36 | 390  | 44826-20 | 483  | 44840-42 | 412  | 44846B09 | 403  | 44873-16 | 281  | 44932-20 | 478  |
| 44625-04 | 471  | 44702T21 | 390  | 44830-52 | 479  | 44840-50 | 411  | 44846B13 | 403  | 44873-17 | 281  | 44934-30 | 478  |
| 44625-05 | 471  | 44702T28 | 390  | 44830-72 | 479  | 44840-51 | 411  | 44846B15 | 403  | 44874-08 | 280  | 44936-02 | 478  |
| 44625-06 | 471  | 44702T36 | 390  | 44830-99 | 479  | 44840-52 | 411  | 44847-09 | 403  | 44874-16 | 280  | 44936-20 | 478  |
| 44625-07 | 471  | 44703B27 | 391  | 44831-52 | 479  | 44840-53 | 411  | 44847-13 | 403  | 44877-11 | 72   | 44936-57 | 478  |
| 44625-08 | 471  | 44703B34 | 391  | 44832-99 | 479  | 44840-54 | 411  | 44847-20 | 403  | 44877-12 | 72   | 44940-01 | 308  |
| 44625-26 | 471  | 44703C27 | 391  | 44833-99 | 479  | 44840-55 | 411  | 44847B09 | 402  | 44877-13 | 73   | 44940-02 | 308  |
| 44625-34 | 471  | 44703C34 | 391  | 44834-00 | 406  | 44840-56 | 411  | 44847B13 | 402  | 44877-14 | 73   | 44940-06 | 308  |
| 44630-01 | 132  | 44703R27 | 392  | 44834-01 | 406  | 44840-57 | 411  | 44847B20 | 402  | 44877-16 | 73   | 44940-08 | 308  |
| 44630-02 | 21   | 44703R34 | 392  | 44834-02 | 406  | 44840-58 | 411  | 44849-27 | 405  | 44877-24 | 72   | 44940-10 | 308  |
| 44630-03 | 132  | 44703S27 | 392  | 44834-03 | 406  | 44841-18 | 403  | 44849-34 | 405  | 44877B11 | 72   | 44940-11 | 309  |
| 44630-04 | 133  | 44703S34 | 392  | 44834G00 | 406  | 44841-21 | 403  | 44849-47 | 405  | 44877B12 | 72   | 44940-12 | 309  |
| 44630-05 | 133  | 44705C37 | 392  | 44834G01 | 406  | 44841-26 | 403  | 44850-00 | 405  | 44877B13 | 73   | 44940-13 | 309  |
| 44630-06 | 21   | 44706B31 | 392  | 44834G02 | 406  | 44841-37 | 403  | 44850-11 | 405  | 44877B14 | 73   | 44940-14 | 309  |
| 44630-07 | 22   | 44706B40 | 392  | 44834G03 | 406  | 44841-51 | 403  | 44850-12 | 405  | 44877B16 | 73   | 44940-16 | 309  |
| 44701B25 | 388  | 44706C31 | 392  | 44835-36 | 406  | 44841B51 | 403  | 44850-13 | 253  | 44877B24 | 72   | 44940-17 | 309  |
| 44701B32 | 388  | 44706C40 | 392  | 44835-45 | 406  | 44842-30 | 404  | 44850B11 | 405  | 44878-11 | 72   | 44940-18 | 309  |
| 44701B40 | 388  | 44706R31 | 394  | 44835-53 | 406  | 44842-31 | 404  | 44850B12 | 405  | 44878-12 | 72   | 44940-19 | 309  |
| 44701C25 | 388  | 44706R40 | 394  | 44835G36 | 406  | 44842-35 | 404  | 44850B13 | 253  | 44878-13 | 73   | 44940-24 | 309  |
| 44701C32 | 388  | 44706S31 | 394  | 44835G45 | 406  | 44842-53 | 404  | 44850G12 | 405  | 44878-14 | 73   | 44940-25 | 309  |
| 44701C40 | 388  | 44706S40 | 394  | 44835G53 | 406  | 44842B31 | 404  | 44851-01 | 405  | 44878-16 | 73   | 44940-26 | 309  |
| 44701M25 | 388  | 44708B28 | 394  | 44836-30 | 406  | 44842B53 | 404  | 44851-02 | 405  | 44878-24 | 72   | 44940-32 | 310  |
| 44701M32 | 388  | 44708C28 | 394  | 44836G30 | 406  | 44843-11 | 404  | 44851-03 | 405  | 44878B11 | 72   | 44940-33 | 310  |
| 44701M40 | 388  | 44708R28 | 395  | 44837-05 | 431  | 44843-12 | 404  | 44871-20 | 310  | 44878B12 | 72   | 44940-34 | 310  |
| 44701R25 | 388  | 44708S28 | 395  | 44837-20 | 431  | 44843-13 | 404  | 44871-21 | 310  | 44878B13 | 73   | 44941B05 | 300  |
| 44701R32 | 388  | 44801-09 | 482  | 44837-25 | 431  | 44843-14 | 404  | 44871-22 | 310  | 44878B14 | 73   | 44941C05 | 300  |
| 44701R40 | 388  | 44801-18 | 483  | 44837B05 | 430  | 44843-24 | 404  | 44871-23 | 310  | 44878B16 | 73   | 44941G05 | 300  |
| 44701S25 | 389  | 44803-10 | 481  | 44837B20 | 430  | 44843B11 | 404  | 44871-28 | 310  | 44878B24 | 72   | 44942-01 | 311  |
| 44701S32 | 389  | 44803-20 | 481  | 44837B25 | 430  | 44843B12 | 404  | 44871-29 | 311  | 44882-35 | 409  | 44942-02 | 311  |
| 44701S40 | 389  | 44803-30 | 481  | 44837C20 | 431  | 44843B13 | 404  | 44871-30 | 310  | 44882-46 | 409  | 44942-03 | 311  |
| 44701T25 | 389  | 44807-18 | 482  | 44840-01 | 402  | 44843B14 | 404  | 44871-31 | 311  | 44884-12 | 432  | 44942-04 | 311  |



| Cod.     | pag. | Cod.     | pag. | Cod.     | pag. | Cod.     | pag. | Cod.     | pag. | Cod.     | pag. | Cod.     | pag. |
|----------|------|----------|------|----------|------|----------|------|----------|------|----------|------|----------|------|
| 44942-05 | 311  | 44970-15 | 475  | 44991-29 | 104  | 47026-06 | 196  | 47042-19 | 248  | 47070-60 | 200  | 47106-46 | 187  |
| 44942-06 | 290  | 44970-20 | 475  | 44992-02 | 350  | 47027-11 | 196  | 47042-22 | 248  | 47074-01 | 200  | 47106-50 | 187  |
| 44942-07 | 290  | 44970-34 | 475  | 44992-03 | 350  | 47027-12 | 196  | 47042-25 | 248  | 47074-02 | 200  | 47106-55 | 187  |
| 44942-10 | 290  | 44972-20 | 475  | 44993-01 | 351  | 47027-13 | 196  | 47043-27 | 248  | 47074-03 | 200  | 47106-60 | 187  |
| 44942-11 | 290  | 44972-25 | 475  | 44994-00 | 350  | 47027-14 | 196  | 47043-35 | 248  | 47074-04 | 200  | 47106-65 | 187  |
| 44942-12 | 290  | 44972-33 | 475  | 44995-10 | 351  | 47027-15 | 196  | 47043-42 | 248  | 47074-05 | 200  | 47106-70 | 187  |
| 44944C07 | 298  | 44973-10 | 475  | 44995-14 | 351  | 47027-16 | 196  | 47060-06 | 206  | 47074-06 | 200  | 47106-75 | 187  |
| 44944G07 | 298  | 44973-20 | 475  | 44995-15 | 351  | 47028-12 | 196  | 47060-07 | 206  | 47074-07 | 200  | 47107-00 | 189  |
| 44945C05 | 298  | 44974-21 | 475  | 44997-22 | 104  | 47029-12 | 196  | 47060-09 | 206  | 47074-08 | 200  | 47108-00 | 189  |
| 44945G05 | 298  | 44974-27 | 475  | 44997-24 | 104  | 47030-30 | 197  | 47060-10 | 206  | 47075-20 | 199  | 47110-23 | 189  |
| 44946-04 | 416  | 44974-31 | 475  | 44997-26 | 104  | 47031-44 | 195  | 47060-12 | 206  | 47075-30 | 199  | 47111-30 | 188  |
| 44946B05 | 416  | 44975-35 | 207  | 44997-28 | 104  | 47031-46 | 195  | 47060-14 | 206  | 47075-45 | 199  | 47111-40 | 188  |
| 44947-00 | 164  | 44975-50 | 207  | 44998-31 | 104  | 47032-10 | 197  | 47060-16 | 206  | 47090-23 | 283  | 47111-46 | 188  |
| 44947-07 | 116  | 44975C50 | 468  | 44999-09 | 350  | 47032-20 | 197  | 47060-18 | 206  | 47091-01 | 283  | 47111-55 | 188  |
| 44948-07 | 301  | 44975H35 | 207  | 44999-16 | 350  | 47033-08 | 197  | 47060-20 | 206  | 47091-02 | 283  | 47112-34 | 188  |
| 44949-01 | 302  | 44975H50 | 207  | 46116-15 | 315  | 47033-12 | 197  | 47060-22 | 206  | 47093-24 | 116  | 47112-45 | 188  |
| 44949-02 | 301  | 44976-01 | 477  | 46118-20 | 363  | 47033-14 | 197  | 47060-24 | 206  | 47094-30 | 189  | 47112-50 | 188  |
| 44949-03 | 302  | 44976-02 | 477  | 46120-18 | 363  | 47033-50 | 194  | 47060-26 | 206  | 47098-18 | 190  | 47113-03 | 189  |
| 44949-04 | 302  | 44976-03 | 477  | 46120-22 | 363  | 47034-23 | 197  | 47060-30 | 206  | 47098-22 | 190  | 47114-40 | 188  |
| 44949-05 | 302  | 44976-04 | 476  | 46120-24 | 363  | 47034-50 | 197  | 47062-18 | 206  | 47098-26 | 190  | 47114-55 | 188  |
| 44949-06 | 302  | 44977-12 | 478  | 46123-00 | 364  | 47034-51 | 197  | 47062-20 | 206  | 47098-30 | 190  | 47118-30 | 188  |
| 44950-15 | 353  | 44978-10 | 475  | 46796-00 | 323  | 47034-52 | 197  | 47062-22 | 206  | 47099-30 | 280  | 47118-40 | 188  |
| 44950-20 | 353  | 44978-20 | 475  | 46970-18 | 30   | 47035-40 | 197  | 47063-01 | 206  | 47100-03 | 415  | 47118-55 | 188  |
| 44950-25 | 353  | 44979-02 | 476  | 46970-25 | 30   | 47035-48 | 197  | 47063-02 | 206  | 47100-04 | 415  | 47118-65 | 188  |
| 44950-30 | 353  | 44979-04 | 476  | 47005-24 | 209  | 47036-30 | 197  | 47063-05 | 206  | 47100-05 | 415  | 47119-30 | 187  |
| 44950-38 | 353  | 44979-05 | 476  | 47006-25 | 209  | 47036-35 | 197  | 47063-07 | 206  | 47100-06 | 415  | 47119-35 | 187  |
| 44960-01 | 269  | 44979-06 | 476  | 47007-26 | 213  | 47036-40 | 197  | 47063-10 | 206  | 47100-07 | 415  | 47119-40 | 187  |
| 44960-02 | 269  | 44982-04 | 248  | 47010-20 | 188  | 47036-45 | 197  | 47064-18 | 206  | 47100-08 | 415  | 47119-45 | 187  |
| 44960-03 | 269  | 44982-06 | 248  | 47011-01 | 201  | 47036-50 | 197  | 47064-22 | 206  | 47101-30 | 189  | 47119-50 | 187  |
| 44960-04 | 269  | 44982-10 | 248  | 47014-35 | 211  | 47036-60 | 197  | 47064-26 | 206  | 47101-31 | 280  | 47119-60 | 187  |
| 44960-06 | 269  | 44986-12 | 475  | 47018-30 | 211  | 47037-30 | 197  | 47064-30 | 206  | 47101-40 | 189  | 47120-01 | 187  |
| 44960-07 | 269  | 44986-17 | 475  | 47018-50 | 211  | 47037-40 | 197  | 47066-03 | 206  | 47103-30 | 189  | 47120-02 | 187  |
| 44960-10 | 270  | 44986-21 | 475  | 47020-15 | 187  | 47038-50 | 197  | 47066-04 | 206  | 47103-32 | 189  | 47127-04 | 184  |
| 44960-11 | 270  | 44986-28 | 475  | 47020-20 | 187  | 47038-60 | 197  | 47066-05 | 206  | 47104-45 | 188  | 47127-06 | 184  |
| 44960-13 | 270  | 44987-11 | 476  | 47020-30 | 187  | 47039-05 | 197  | 47066-06 | 206  | 47105-28 | 187  | 47127-08 | 184  |
| 44960K10 | 270  | 44987-60 | 476  | 47020-35 | 187  | 47039-10 | 197  | 47066-07 | 206  | 47105-34 | 187  | 47130-25 | 201  |
| 44960K11 | 270  | 44987C11 | 476  | 47021-35 | 187  | 47039-15 | 198  | 47066-08 | 206  | 47105-40 | 187  | 47130-30 | 201  |
| 44961-02 | 476  | 44987C60 | 476  | 47021-45 | 187  | 47040-00 | 248  | 47068-12 | 206  | 47105-46 | 187  | 47130-35 | 201  |
| 44961-03 | 269  | 44987C62 | 475  | 47022-12 | 199  | 47041-01 | 247  | 47068-15 | 206  | 47105-50 | 187  | 47130-40 | 201  |
| 44961-04 | 475  | 44990-15 | 310  | 47023-01 | 277  | 47041-02 | 247  | 47069-10 | 206  | 47105-55 | 187  | 47130-45 | 201  |
| 44961-05 | 475  | 44990-24 | 310  | 47023-02 | 277  | 47041-03 | 247  | 47069-12 | 206  | 47105-60 | 187  | 47130-50 | 201  |
| 44961-06 | 475  | 44990-29 | 310  | 47023-03 | 277  | 47041-04 | 247  | 47069-14 | 206  | 47105-65 | 187  | 47130-55 | 201  |
| 44961M03 | 269  | 44990-36 | 310  | 47023-04 | 277  | 47041-05 | 247  | 47069-16 | 206  | 47105-70 | 187  | 47130-60 | 201  |
| 44962-01 | 269  | 44990-48 | 310  | 47024-06 | 196  | 47041-06 | 247  | 47069-18 | 206  | 47105-75 | 187  | 47131-30 | 201  |
| 44962-05 | 270  | 44991-22 | 104  | 47024-10 | 196  | 47041-07 | 247  | 47069-20 | 206  | 47106-28 | 187  | 47131-60 | 201  |
| 44968-00 | 476  | 44991-24 | 104  | 47025-06 | 196  | 47041-08 | 247  | 47070-37 | 200  | 47106-34 | 187  | 47200-01 | 186  |
| 44970-10 | 475  | 44991-28 | 104  | 47025-10 | 196  | 47041-15 | 247  | 47070-48 | 200  | 47106-40 | 187  | 47200-02 | 186  |

**NUMERICAL INDEX INDICE NUMERICO NUMERISCH INDEX INDEX NUMERIQUE INDICE NUMERICO**

| Cod.     | pag. | Cod.     | pag. | Cod.     | pag. | Cod.     | pag. | Cod.     | pag. | Cod.     | pag. | Cod.     | pag. |
|----------|------|----------|------|----------|------|----------|------|----------|------|----------|------|----------|------|
| 47207-20 | 184  | 47308-10 | 169  | 47354-18 | 184  | 47373-02 | 176  | 47404-04 | 174  | 47511-11 | 203  | 47532-26 | 202  |
| 47207-25 | 184  | 47310-10 | 169  | 47355-02 | 184  | 47373-08 | 172  | 47404-08 | 175  | 47511-13 | 203  | 47533-07 | 202  |
| 47207-30 | 184  | 47312-10 | 169  | 47355-04 | 184  | 47374-01 | 175  | 47411-01 | 171  | 47511-15 | 203  | 47533-08 | 202  |
| 47208-01 | 183  | 47314-10 | 169  | 47355-06 | 184  | 47374-02 | 175  | 47411-02 | 171  | 47511-17 | 203  | 47533-09 | 202  |
| 47208-02 | 183  | 47315-10 | 169  | 47355-08 | 184  | 47374-08 | 175  | 47411-03 | 172  | 47511-19 | 203  | 47533-10 | 202  |
| 47208-03 | 183  | 47316-10 | 169  | 47355-10 | 184  | 47375-01 | 175  | 47411-08 | 171  | 47511-21 | 203  | 47533-12 | 202  |
| 47208-04 | 183  | 47316-12 | 169  | 47355-12 | 184  | 47375-08 | 175  | 47412-08 | 171  | 47511-23 | 203  | 47533-14 | 202  |
| 47208-05 | 183  | 47316-20 | 169  | 47356-02 | 184  | 47376-08 | 172  | 47413-01 | 171  | 47511-25 | 203  | 47533-16 | 202  |
| 47208-06 | 183  | 47317-10 | 169  | 47356-04 | 184  | 47377-01 | 174  | 47413-08 | 171  | 47511-27 | 203  | 47533-18 | 202  |
| 47208-07 | 183  | 47317-12 | 170  | 47356-06 | 184  | 47377-02 | 173  | 47414-03 | 170  | 47511-29 | 203  | 47533-20 | 202  |
| 47208-08 | 183  | 47321-12 | 170  | 47356-08 | 184  | 47377-03 | 173  | 47415-03 | 170  | 47511-31 | 203  | 47533-22 | 202  |
| 47208-09 | 183  | 47322-12 | 170  | 47356-10 | 184  | 47377-04 | 174  | 47416-06 | 170  | 47512-07 | 203  | 47533-24 | 202  |
| 47208-10 | 183  | 47323-12 | 170  | 47356-12 | 184  | 47377-05 | 174  | 47417-06 | 170  | 47512-09 | 203  | 47533-26 | 202  |
| 47208-11 | 183  | 47324-12 | 170  | 47356-14 | 184  | 47377-06 | 174  | 47419-10 | 170  | 47512-11 | 203  | 47533-28 | 202  |
| 47208-12 | 183  | 47325-10 | 170  | 47356-16 | 184  | 47377-07 | 174  | 47421-09 | 176  | 47512-13 | 203  | 47533-30 | 202  |
| 47208-13 | 183  | 47326-10 | 170  | 47356-18 | 184  | 47377-08 | 171  | 47422-26 | 176  | 47512-15 | 203  | 47533-32 | 202  |
| 47208-14 | 183  | 47327-12 | 170  | 47357-02 | 182  | 47377-09 | 173  | 47425-01 | 177  | 47512-17 | 203  | 47534-00 | 202  |
| 47208-15 | 183  | 47328-15 | 170  | 47357-03 | 182  | 47377-10 | 173  | 47425-02 | 177  | 47512-19 | 203  | 47534-01 | 202  |
| 47208-16 | 183  | 47331-15 | 170  | 47357-06 | 181  | 47377-11 | 174  | 47425-03 | 177  | 47512-21 | 203  | 47534-06 | 202  |
| 47208-17 | 184  | 47332-12 | 170  | 47357-07 | 181  | 47377-12 | 177  | 47425-04 | 177  | 47512-23 | 203  | 47534-07 | 202  |
| 47208-18 | 184  | 47333-15 | 170  | 47357-08 | 182  | 47377-15 | 177  | 47425-05 | 177  | 47512-25 | 203  | 47534-08 | 202  |
| 47208-19 | 184  | 47334-12 | 170  | 47357-09 | 182  | 47378-01 | 176  | 47425-06 | 177  | 47512-27 | 203  | 47534-09 | 202  |
| 47208-20 | 184  | 47335-12 | 170  | 47357-10 | 182  | 47378-02 | 176  | 47425-08 | 177  | 47512-29 | 203  | 47534-10 | 202  |
| 47208-21 | 184  | 47336-42 | 170  | 47357-11 | 182  | 47378-08 | 171  | 47425-09 | 177  | 47512-31 | 203  | 47534-16 | 202  |
| 47208-22 | 184  | 47350-01 | 183  | 47357-20 | 180  | 47379-08 | 171  | 47425-10 | 177  | 47526-05 | 204  | 47534-18 | 202  |
| 47208-23 | 184  | 47351-01 | 183  | 47357-21 | 180  | 47380-08 | 175  | 47425-11 | 177  | 47527-55 | 204  | 47534-20 | 202  |
| 47208-24 | 184  | 47352-01 | 183  | 47357-22 | 180  | 47381-08 | 176  | 47425-26 | 177  | 47528-05 | 204  | 47534-22 | 202  |
| 47212-01 | 186  | 47353-02 | 184  | 47357-24 | 180  | 47382-06 | 174  | 47425-29 | 177  | 47529-07 | 202  | 47534-24 | 202  |
| 47212-02 | 186  | 47353-04 | 184  | 47357-28 | 181  | 47382-08 | 173  | 47425-30 | 177  | 47530-14 | 202  | 47534-26 | 202  |
| 47212-03 | 186  | 47353-06 | 184  | 47357-29 | 181  | 47383-08 | 175  | 47425-32 | 177  | 47530-16 | 202  | 47534-28 | 202  |
| 47212-05 | 186  | 47353-08 | 184  | 47357-30 | 181  | 47384-01 | 175  | 47426-01 | 177  | 47530-18 | 202  | 47535-09 | 205  |
| 47214-86 | 185  | 47353-10 | 184  | 47357-31 | 181  | 47384-08 | 175  | 47426-07 | 177  | 47530-20 | 202  | 47535-12 | 205  |
| 47215-86 | 185  | 47353-12 | 184  | 47357-38 | 186  | 47385-01 | 176  | 47510-07 | 203  | 47530-22 | 202  | 47535-15 | 205  |
| 47219-29 | 186  | 47353-14 | 184  | 47357-40 | 185  | 47385-08 | 176  | 47510-09 | 203  | 47530-24 | 202  | 47535-17 | 205  |
| 47219-38 | 186  | 47353-16 | 184  | 47357-41 | 185  | 47386-08 | 175  | 47510-11 | 203  | 47530-26 | 202  | 47535-19 | 205  |
| 47219-55 | 186  | 47353-18 | 184  | 47357-42 | 185  | 47387-01 | 172  | 47510-13 | 203  | 47530-28 | 202  | 47536-12 | 205  |
| 47250-12 | 185  | 47353-20 | 184  | 47357-43 | 185  | 47387-02 | 173  | 47510-15 | 203  | 47530-30 | 202  | 47536-14 | 205  |
| 47250-24 | 185  | 47353-22 | 184  | 47357-44 | 185  | 47388-06 | 177  | 47510-17 | 203  | 47532-06 | 202  | 47536-16 | 205  |
| 47301-12 | 169  | 47353-24 | 184  | 47357-50 | 185  | 47388-07 | 177  | 47510-19 | 203  | 47532-07 | 202  | 47536-18 | 205  |
| 47302-10 | 169  | 47354-02 | 184  | 47357-51 | 185  | 47388-08 | 177  | 47510-21 | 203  | 47532-08 | 202  | 47536-20 | 205  |
| 47303-10 | 169  | 47354-04 | 184  | 47370-01 | 176  | 47401-08 | 175  | 47510-23 | 203  | 47532-12 | 202  | 47538-20 | 205  |
| 47304-06 | 169  | 47354-06 | 184  | 47370-02 | 176  | 47402-01 | 172  | 47510-25 | 203  | 47532-14 | 202  | 47538-23 | 205  |
| 47304-10 | 169  | 47354-08 | 184  | 47370-03 | 176  | 47402-02 | 172  | 47510-27 | 203  | 47532-16 | 202  | 47538-26 | 205  |
| 47304-12 | 169  | 47354-10 | 184  | 47370-08 | 171  | 47402-08 | 172  | 47510-29 | 203  | 47532-18 | 202  | 47540-02 | 205  |
| 47305-12 | 169  | 47354-12 | 184  | 47371-08 | 174  | 47404-01 | 175  | 47510-31 | 203  | 47532-20 | 202  | 47540-03 | 205  |
| 47306-10 | 169  | 47354-14 | 184  | 47372-08 | 172  | 47404-02 | 175  | 47511-07 | 203  | 47532-22 | 202  | 47540-04 | 205  |
| 47307-10 | 169  | 47354-16 | 184  | 47373-01 | 173  | 47404-03 | 175  | 47511-09 | 203  | 47532-24 | 202  | 47540-05 | 205  |

| Cod.     | pag. | Cod.     | pag. | Cod.     | pag. | Cod.     | pag. | Cod.     | pag. | Cod.     | pag. | Cod.     | pag. |
|----------|------|----------|------|----------|------|----------|------|----------|------|----------|------|----------|------|
| 47541-02 | 204  | 47604-30 | 105  | 47621-07 | 199  | 47655-05 | 215  | 47686-42 | 189  | 47719-10 | 210  | 47740-02 | 235  |
| 47541-03 | 204  | 47605-23 | 104  | 47621-08 | 199  | 47655-07 | 215  | 47687-24 | 189  | 47719-24 | 210  | 47740-03 | 235  |
| 47541-04 | 204  | 47606-02 | 105  | 47621-11 | 271  | 47656-01 | 215  | 47688-60 | 201  | 47720-06 | 211  | 47740-04 | 238  |
| 47542-00 | 204  | 47606-05 | 105  | 47621-12 | 271  | 47656-02 | 215  | 47689-53 | 200  | 47720-08 | 211  | 47740-05 | 238  |
| 47542-18 | 205  | 47606-10 | 105  | 47622-01 | 179  | 47656-03 | 215  | 47689-60 | 200  | 47720-10 | 211  | 47740-06 | 234  |
| 47542-20 | 205  | 47606-20 | 105  | 47622-02 | 179  | 47656-04 | 215  | 47691-53 | 200  | 47720-12 | 211  | 47740-07 | 241  |
| 47542-22 | 205  | 47606-30 | 105  | 47622-03 | 179  | 47656-05 | 215  | 47691-64 | 200  | 47721-08 | 212  | 47740-08 | 241  |
| 47542-24 | 205  | 47606-50 | 105  | 47622-04 | 178  | 47656-07 | 215  | 47692-01 | 195  | 47721-10 | 212  | 47740-09 | 239  |
| 47542-26 | 205  | 47607-10 | 105  | 47622-26 | 178  | 47657-01 | 215  | 47692-02 | 195  | 47721-12 | 212  | 47740-10 | 234  |
| 47544-20 | 204  | 47607-20 | 105  | 47625-03 | 199  | 47657-02 | 215  | 47692-03 | 195  | 47722-05 | 212  | 47740100 | 240  |
| 47544-25 | 204  | 47608-02 | 105  | 47626-55 | 194  | 47657-03 | 215  | 47693-00 | 195  | 47722-06 | 212  | 47740101 | 236  |
| 47544-30 | 204  | 47609-02 | 106  | 47627-01 | 194  | 47657-04 | 215  | 47693-03 | 195  | 47722-07 | 212  | 47740102 | 234  |
| 47546-18 | 204  | 47609-03 | 106  | 47630-28 | 179  | 47657-05 | 215  | 47693-05 | 195  | 47722-08 | 212  | 47740103 | 234  |
| 47546-21 | 205  | 47609-04 | 106  | 47631-08 | 179  | 47657-07 | 215  | 47693-10 | 195  | 47722-10 | 212  | 47740104 | 238  |
| 47546-22 | 205  | 47609-07 | 106  | 47631-12 | 179  | 47658-01 | 215  | 47693-15 | 195  | 47723-05 | 212  | 47740105 | 233  |
| 47546-23 | 205  | 47609-09 | 106  | 47640-25 | 198  | 47658-02 | 215  | 47694-03 | 192  | 47723-06 | 212  | 47740106 | 237  |
| 47546-30 | 204  | 47609-12 | 106  | 47640-35 | 198  | 47658-03 | 215  | 47698-01 | 193  | 47723-07 | 212  | 47740107 | 241  |
| 47546-40 | 204  | 47609-13 | 106  | 47640-50 | 198  | 47658-04 | 215  | 47698-02 | 193  | 47723-08 | 212  | 47740108 | 241  |
| 47546-41 | 205  | 47609-16 | 106  | 47640-59 | 198  | 47658-05 | 215  | 47698-03 | 193  | 47723-10 | 212  | 47740109 | 241  |
| 47546-42 | 205  | 47610-18 | 109  | 47642-30 | 198  | 47658-07 | 215  | 47698-06 | 193  | 47723-12 | 212  | 47740-11 | 240  |
| 47546-43 | 205  | 47610-22 | 109  | 47642-40 | 198  | 47659-01 | 214  | 47698-07 | 193  | 47724-06 | 212  | 47740110 | 241  |
| 47546-51 | 205  | 47610-26 | 109  | 47642-50 | 198  | 47659-02 | 214  | 47705-22 | 210  | 47724-08 | 212  | 47740111 | 237  |
| 47546-52 | 205  | 47610-30 | 109  | 47642-60 | 198  | 47659-03 | 214  | 47709-20 | 209  | 47724-10 | 212  | 47740112 | 242  |
| 47546-53 | 205  | 47611-01 | 110  | 47642-70 | 198  | 47659-04 | 214  | 47709-24 | 209  | 47724-11 | 212  | 47740113 | 242  |
| 47547-22 | 204  | 47611-03 | 110  | 47644-15 | 198  | 47670-02 | 214  | 47709-28 | 209  | 47725-09 | 212  | 47740114 | 239  |
| 47547-26 | 204  | 47611-05 | 110  | 47645-40 | 198  | 47672-05 | 214  | 47709-32 | 209  | 47726-07 | 211  | 47740115 | 240  |
| 47547-30 | 204  | 47611-06 | 110  | 47645-60 | 198  | 47679-10 | 199  | 47710-12 | 209  | 47727-07 | 211  | 47740116 | 241  |
| 47548-02 | 204  | 47611-09 | 110  | 47645-75 | 198  | 47679-11 | 199  | 47710-16 | 209  | 47728-06 | 211  | 47740117 | 241  |
| 47548-03 | 204  | 47611-11 | 110  | 47646-40 | 198  | 47680-40 | 201  | 47710-20 | 209  | 47730-60 | 212  | 47740119 | 233  |
| 47548-04 | 204  | 47611-13 | 110  | 47646-60 | 198  | 47680-53 | 201  | 47710-24 | 209  | 47731-12 | 213  | 47740-12 | 240  |
| 47548-05 | 204  | 47611-14 | 110  | 47646-75 | 198  | 47680-60 | 201  | 47710-28 | 209  | 47732-20 | 213  | 47740122 | 236  |
| 47600-16 | 110  | 47611-15 | 110  | 47651-01 | 215  | 47681-60 | 200  | 47710-32 | 209  | 47733-18 | 210  | 47740123 | 235  |
| 47600-20 | 110  | 47611-16 | 110  | 47651-02 | 215  | 47682-53 | 200  | 47711-08 | 209  | 47733-24 | 210  | 47740124 | 235  |
| 47600-24 | 110  | 47611-19 | 110  | 47651-03 | 215  | 47682-60 | 200  | 47711-12 | 209  | 47733-30 | 210  | 47740125 | 235  |
| 47600-28 | 110  | 47611-23 | 110  | 47651-04 | 215  | 47684-15 | 214  | 47711-22 | 209  | 47733-36 | 210  | 47740127 | 235  |
| 47600-32 | 110  | 47612-01 | 192  | 47651-05 | 215  | 47685-53 | 201  | 47711-24 | 209  | 47734-18 | 210  | 47740128 | 233  |
| 47600-36 | 110  | 47612-AA | 530  | 47651-07 | 215  | 47685-60 | 201  | 47711-26 | 209  | 47735-18 | 210  | 47740-13 | 238  |
| 47600-40 | 110  | 47614-25 | 199  | 47652-01 | 215  | 47686-10 | 189  | 47712-20 | 209  | 47736-30 | 211  | 47740130 | 235  |
| 47603-25 | 104  | 47615-25 | 199  | 47652-02 | 215  | 47686-12 | 189  | 47712-24 | 209  | 47736-35 | 211  | 47740131 | 237  |
| 47603-27 | 104  | 47618-10 | 185  | 47652-03 | 215  | 47686-14 | 189  | 47712-28 | 209  | 47736-40 | 211  | 47740132 | 235  |
| 47604-08 | 105  | 47618-20 | 185  | 47652-04 | 215  | 47686-17 | 189  | 47712-32 | 209  | 47736-50 | 211  | 47740133 | 236  |
| 47604-10 | 105  | 47621-01 | 198  | 47652-05 | 215  | 47686-22 | 189  | 47713-22 | 209  | 47738-23 | 210  | 47740134 | 242  |
| 47604-12 | 105  | 47621-02 | 198  | 47652-07 | 215  | 47686-24 | 189  | 47714-26 | 210  | 47739-12 | 209  | 47740135 | 234  |
| 47604-15 | 105  | 47621-03 | 198  | 47655-01 | 215  | 47686-26 | 189  | 47714-28 | 210  | 47739-24 | 209  | 47740137 | 233  |
| 47604-18 | 105  | 47621-04 | 198  | 47655-02 | 215  | 47686-30 | 189  | 47715-30 | 210  | 47739-28 | 209  | 47740138 | 233  |
| 47604-20 | 105  | 47621-05 | 198  | 47655-03 | 215  | 47686-33 | 189  | 47717-35 | 210  | 47739-32 | 209  | 47740-14 | 241  |
| 47604-24 | 105  | 47621-06 | 198  | 47655-04 | 215  | 47686-36 | 189  | 47718-20 | 210  | 47740-01 | 240  | 47740142 | 236  |

**NUMERICAL INDEX INDICE NUMERICO NUMERISCH INDEX INDEX NUMERIQUE INDICE NUMERICO**

| Cod.     | pag. | Cod.     | pag. | Cod.     | pag. | Cod.     | pag. | Cod.     | pag. | Cod.     | pag. | Cod.     | pag. |
|----------|------|----------|------|----------|------|----------|------|----------|------|----------|------|----------|------|
| 47740143 | 236  | 47740-65 | 238  | 47742-05 | 229  | 47744-37 | 245  | 47756-26 | 214  | 47800-22 | 191  | 47860-31 | 218  |
| 47740144 | 236  | 47740-66 | 238  | 47742-06 | 230  | 47744-48 | 244  | 47756-28 | 214  | 47801-20 | 191  | 47860-35 | 218  |
| 47740145 | 239  | 47740-67 | 240  | 47742-07 | 230  | 47744-58 | 244  | 47757-65 | 211  | 47820-05 | 196  | 47860-36 | 218  |
| 47740-15 | 239  | 47740-68 | 237  | 47742-08 | 229  | 47744-59 | 244  | 47757-80 | 211  | 47820-07 | 196  | 47860-37 | 218  |
| 47740-16 | 234  | 47740-69 | 234  | 47742-09 | 229  | 47744-60 | 244  | 47758-10 | 210  | 47821-05 | 196  | 47860-38 | 218  |
| 47740-17 | 236  | 47740-70 | 234  | 47742-10 | 230  | 47744-62 | 244  | 47758-12 | 210  | 47821-07 | 196  | 47860-39 | 218  |
| 47740-18 | 234  | 47740-71 | 238  | 47742-12 | 228  | 47744-63 | 245  | 47759-12 | 211  | 47822-05 | 196  | 47860-40 | 218  |
| 47740-19 | 237  | 47740-72 | 238  | 47742-13 | 229  | 47744-70 | 245  | 47760-12 | 211  | 47822-07 | 196  | 47860-42 | 218  |
| 47740-20 | 239  | 47740-73 | 242  | 47742-14 | 229  | 47744-71 | 245  | 47761-23 | 213  | 47831-02 | 107  | 47860-43 | 218  |
| 47740-23 | 233  | 47740-74 | 234  | 47742-15 | 230  | 47744-80 | 244  | 47762-23 | 213  | 47832-00 | 368  | 47860-44 | 218  |
| 47740-24 | 239  | 47740-75 | 234  | 47742-16 | 230  | 47744-81 | 244  | 47764-12 | 214  | 47832-01 | 287  | 47860-46 | 218  |
| 47740-25 | 238  | 47740-77 | 236  | 47742-17 | 228  | 47745-02 | 227  | 47764-28 | 214  | 47832-02 | 368  | 47860-48 | 218  |
| 47740-26 | 233  | 47740-79 | 239  | 47742-19 | 229  | 47745-03 | 227  | 47765-24 | 230  | 47832-03 | 287  | 47860-49 | 218  |
| 47740-27 | 233  | 47740-80 | 233  | 47742-20 | 229  | 47745-04 | 227  | 47765-26 | 230  | 47832-04 | 287  | 47860-50 | 218  |
| 47740-28 | 233  | 47740-81 | 237  | 47742-21 | 229  | 47745-05 | 227  | 47765-28 | 230  | 47832-05 | 287  | 47860-53 | 219  |
| 47740-29 | 233  | 47740-82 | 236  | 47742-23 | 229  | 47745-06 | 226  | 47766-26 | 230  | 47832-10 | 368  | 47860-55 | 219  |
| 47740-30 | 238  | 47740-83 | 234  | 47742-24 | 230  | 47745-07 | 226  | 47766-28 | 230  | 47832-11 | 368  | 47860-56 | 219  |
| 47740-31 | 240  | 47740-84 | 241  | 47742-25 | 229  | 47745-08 | 226  | 47766-30 | 230  | 47832-12 | 368  | 47860-58 | 219  |
| 47740-32 | 237  | 47740-85 | 238  | 47742-27 | 228  | 47745-09 | 226  | 47769-28 | 231  | 47832-13 | 368  | 47860-60 | 219  |
| 47740-33 | 240  | 47740-86 | 241  | 47742-29 | 230  | 47745-10 | 226  | 47770-21 | 231  | 47832-14 | 368  | 47860-61 | 219  |
| 47740-34 | 237  | 47740-87 | 240  | 47742-30 | 228  | 47746-01 | 227  | 47771-28 | 231  | 47832-15 | 368  | 47860-62 | 219  |
| 47740-35 | 242  | 47740-88 | 242  | 47742-31 | 228  | 47746-02 | 227  | 47773-24 | 231  | 47833-04 | 179  | 47860-63 | 219  |
| 47740-36 | 239  | 47740-89 | 235  | 47742-33 | 229  | 47746-03 | 227  | 47773-28 | 231  | 47833-10 | 179  | 47860-66 | 219  |
| 47740-37 | 235  | 47740-90 | 240  | 47742-34 | 229  | 47746-04 | 227  | 47783-01 | 216  | 47837-09 | 179  | 47860-67 | 219  |
| 47740-38 | 235  | 47740-91 | 240  | 47742-37 | 229  | 47747-01 | 212  | 47783-02 | 216  | 47838-00 | 193  | 47860-68 | 219  |
| 47740-39 | 238  | 47740-92 | 237  | 47742-41 | 228  | 47747-03 | 212  | 47783-03 | 216  | 47840-11 | 193  | 47860-69 | 219  |
| 47740-41 | 235  | 47740-93 | 233  | 47742-42 | 229  | 47747-04 | 212  | 47783-04 | 216  | 47841-03 | 193  | 47860-70 | 219  |
| 47740-43 | 234  | 47740-94 | 236  | 47742-47 | 230  | 47747-05 | 213  | 47783-11 | 216  | 47841-04 | 193  | 47860-71 | 219  |
| 47740-44 | 237  | 47740-95 | 235  | 47742-48 | 230  | 47747-06 | 212  | 47783-12 | 216  | 47842-00 | 194  | 47860-73 | 219  |
| 47740-45 | 238  | 47740-96 | 241  | 47742-51 | 228  | 47747-07 | 213  | 47783-13 | 216  | 47843-00 | 127  | 47860-74 | 219  |
| 47740-46 | 237  | 47740-97 | 236  | 47742-56 | 228  | 47747-09 | 213  | 47783-14 | 216  | 47843-05 | 127  | 47860-75 | 220  |
| 47740-47 | 237  | 47740-98 | 240  | 47742-61 | 230  | 47747-10 | 212  | 47793-11 | 225  | 47844-01 | 192  | 47860-76 | 223  |
| 47740-48 | 237  | 47740-99 | 239  | 47743-03 | 242  | 47747-11 | 212  | 47793-12 | 225  | 47844-02 | 192  | 47860-77 | 223  |
| 47740-49 | 237  | 47741-00 | 243  | 47743-05 | 242  | 47748-35 | 213  | 47793-13 | 225  | 47844-06 | 192  | 47860-78 | 223  |
| 47740-50 | 236  | 47741-01 | 243  | 47743-10 | 242  | 47749-35 | 213  | 47793-15 | 225  | 47846-10 | 192  | 47860-81 | 220  |
| 47740-51 | 239  | 47741-02 | 243  | 47743-13 | 242  | 47750-06 | 213  | 47793-16 | 225  | 47847-10 | 192  | 47860-83 | 220  |
| 47740-52 | 234  | 47741-05 | 243  | 47743-15 | 243  | 47752-09 | 211  | 47793-18 | 225  | 47847-12 | 192  | 47860-84 | 220  |
| 47740-53 | 242  | 47741-37 | 244  | 47743-16 | 243  | 47752-16 | 211  | 47793-20 | 225  | 47847-23 | 192  | 47860-85 | 220  |
| 47740-55 | 238  | 47741-38 | 244  | 47743-65 | 243  | 47752-21 | 211  | 47793-23 | 225  | 47848-07 | 192  | 47860-86 | 223  |
| 47740-56 | 239  | 47741-76 | 243  | 47744-10 | 244  | 47753-31 | 211  | 47793-26 | 225  | 47859-01 | 276  | 47860-90 | 223  |
| 47740-57 | 234  | 47741-77 | 243  | 47744-19 | 244  | 47754-20 | 214  | 47793-32 | 225  | 47859-02 | 276  | 47860-95 | 220  |
| 47740-58 | 234  | 47741-78 | 243  | 47744-21 | 245  | 47754-24 | 214  | 47793-33 | 225  | 47859-03 | 276  | 47860-96 | 220  |
| 47740-59 | 234  | 47742-00 | 231  | 47744-30 | 243  | 47754-26 | 214  | 47793-40 | 225  | 47860-17 | 217  | 47861-02 | 217  |
| 47740-60 | 234  | 47742-01 | 230  | 47744-31 | 244  | 47754-28 | 214  | 47793-43 | 225  | 47860-18 | 218  | 47861-03 | 217  |
| 47740-62 | 238  | 47742-02 | 228  | 47744-32 | 243  | 47755-26 | 214  | 47793-45 | 225  | 47860-21 | 218  | 47861-04 | 217  |
| 47740-63 | 239  | 47742-03 | 230  | 47744-34 | 244  | 47756-20 | 214  | 47793-52 | 225  | 47860-24 | 218  | 47861-05 | 217  |
| 47740-64 | 238  | 47742-04 | 230  | 47744-36 | 245  | 47756-24 | 214  | 47793-55 | 225  | 47860-27 | 218  | 47861-06 | 217  |



| Cod.     | pag. | Cod.     | pag. | Cod.     | pag. | Cod.     | pag. | Cod.     | pag. | Cod.     | pag. | Cod.     | pag. |
|----------|------|----------|------|----------|------|----------|------|----------|------|----------|------|----------|------|
| 47861-07 | 217  | 47862-89 | 224  | 48220-00 | 123  | 48278-20 | 90   | 48278-89 | 94   | 48280-61 | 87   | 48313-14 | 303  |
| 47861-08 | 217  | 47862C10 | 222  | 48222-01 | 123  | 48278-21 | 90   | 48278-91 | 92   | 48280-62 | 87   | 48313-18 | 303  |
| 47861-09 | 217  | 47865-23 | 224  | 48223-00 | 325  | 48278-24 | 88   | 48278-92 | 92   | 48280-63 | 87   | 48313-20 | 303  |
| 47861-10 | 217  | 47865-44 | 224  | 48231-40 | 162  | 48278-25 | 91   | 48278-93 | 93   | 48280-75 | 85   | 48350-01 | 292  |
| 47861-11 | 217  | 47865-66 | 224  | 48231-45 | 162  | 48278-27 | 93   | 48278-94 | 90   | 48280-85 | 86   | 48350-02 | 292  |
| 47861-12 | 217  | 47865-71 | 224  | 48231-50 | 162  | 48278-28 | 94   | 48278-95 | 91   | 48280-90 | 88   | 48350-03 | 292  |
| 47861-13 | 217  | 47865-72 | 224  | 48232-40 | 530  | 48278-31 | 90   | 48278-96 | 91   | 48280-91 | 87   | 48350-04 | 292  |
| 47861-14 | 217  | 47865-73 | 224  | 48232-45 | 530  | 48278-32 | 88   | 48278-99 | 92   | 48280-92 | 88   | 48351-01 | 293  |
| 47861-15 | 217  | 47865-74 | 224  | 48232-50 | 530  | 48278-33 | 88   | 48280-02 | 86   | 48280-94 | 85   | 48351-02 | 293  |
| 47861-16 | 223  | 47865-75 | 224  | 48236-00 | 355  | 48278-34 | 91   | 48280-03 | 86   | 48280-95 | 88   | 48351-03 | 293  |
| 47862-03 | 221  | 47865-76 | 224  | 48236-01 | 355  | 48278-35 | 91   | 48280-04 | 84   | 48280-96 | 87   | 48352-01 | 293  |
| 47862-04 | 221  | 47865-77 | 224  | 48237-00 | 355  | 48278-36 | 92   | 48280-05 | 84   | 48280-97 | 87   | 48352-02 | 293  |
| 47862-05 | 221  | 47865-80 | 224  | 48237-01 | 355  | 48278-37 | 90   | 48280-06 | 85   | 48281-22 | 117  | 48352-03 | 293  |
| 47862-06 | 222  | 47865-81 | 224  | 48237-35 | 355  | 48278-38 | 88   | 48280-08 | 87   | 48281-23 | 117  | 48353-01 | 292  |
| 47862-07 | 222  | 47865-82 | 224  | 48237-99 | 355  | 48278-39 | 88   | 48280-09 | 85   | 48282-21 | 118  | 48354-01 | 292  |
| 47862-08 | 222  | 47865-83 | 224  | 48238-00 | 361  | 48278-41 | 89   | 48280-10 | 86   | 48286-03 | 120  | 48355-01 | 336  |
| 47862-09 | 222  | 47870-17 | 223  | 48239-00 | 361  | 48278-42 | 89   | 48280-11 | 87   | 48286-08 | 120  | 48356-01 | 336  |
| 47862-10 | 222  | 47870-18 | 223  | 48240-00 | 361  | 48278-45 | 90   | 48280-12 | 85   | 48286-13 | 120  | 48357-01 | 336  |
| 47862-31 | 220  | 47870-19 | 223  | 48241-14 | 370  | 48278-46 | 89   | 48280-13 | 85   | 48286-62 | 116  | 48358-01 | 336  |
| 47862-32 | 220  | 47875-11 | 216  | 48242-09 | 369  | 48278-47 | 91   | 48280-15 | 87   | 48286-64 | 116  | 48359-01 | 336  |
| 47862-33 | 220  | 47875-13 | 216  | 48244-04 | 369  | 48278-48 | 89   | 48280-20 | 84   | 48286-67 | 86   | 48362-01 | 326  |
| 47862-34 | 220  | 47875-14 | 216  | 48244-07 | 369  | 48278-49 | 89   | 48280-21 | 84   | 48286-68 | 361  | 48363-01 | 326  |
| 47862-35 | 220  | 47876-11 | 224  | 48245-10 | 370  | 48278-52 | 91   | 48280-23 | 88   | 48286-70 | 119  | 48364-09 | 326  |
| 47862-36 | 220  | 47876-12 | 224  | 48245-75 | 370  | 48278-53 | 91   | 48280-24 | 86   | 48287-18 | 368  | 48364-12 | 326  |
| 47862-38 | 220  | 47876-13 | 224  | 48247-10 | 369  | 48278-54 | 91   | 48280-25 | 88   | 48287-19 | 368  | 48365-09 | 292  |
| 47862-39 | 220  | 47876-14 | 224  | 48249-13 | 369  | 48278-55 | 89   | 48280-26 | 86   | 48288-02 | 116  | 48366-09 | 292  |
| 47862-64 | 221  | 47885-01 | 121  | 48250-10 | 369  | 48278-61 | 92   | 48280-27 | 157  | 48288-03 | 116  | 48367-10 | 291  |
| 47862-65 | 221  | 47885-02 | 121  | 48250-12 | 369  | 48278-62 | 92   | 48280-30 | 86   | 48289-10 | 115  | 48368-05 | 335  |
| 47862-66 | 221  | 47885-03 | 121  | 48251-03 | 369  | 48278-63 | 93   | 48280-31 | 86   | 48290-10 | 248  | 48368-12 | 335  |
| 47862-67 | 221  | 47885-04 | 121  | 48252-10 | 369  | 48278-64 | 92   | 48280-32 | 84   | 48294-01 | 121  | 48368-20 | 335  |
| 47862-70 | 222  | 47885-05 | 121  | 48252-12 | 369  | 48278-65 | 93   | 48280-34 | 87   | 48294-02 | 121  | 48369-08 | 335  |
| 47862-71 | 222  | 48017-14 | 151  | 48252B10 | 369  | 48278-66 | 92   | 48280-35 | 86   | 48294-03 | 121  | 48369-14 | 335  |
| 47862-72 | 222  | 48017-25 | 151  | 48252B12 | 369  | 48278-68 | 92   | 48280-36 | 86   | 48294-04 | 121  | 48369-20 | 335  |
| 47862-73 | 222  | 48021-21 | 151  | 48253-09 | 369  | 48278-69 | 92   | 48280-37 | 85   | 48295-10 | 118  | 48370-10 | 292  |
| 47862-74 | 222  | 48032-30 | 159  | 48253B09 | 369  | 48278-71 | 93   | 48280-38 | 84   | 48300-29 | 256  | 48370-11 | 292  |
| 47862-75 | 222  | 48032-45 | 159  | 48278-01 | 90   | 48278-73 | 93   | 48280-39 | 84   | 48300-33 | 256  | 48371-10 | 291  |
| 47862-76 | 222  | 48032-60 | 159  | 48278-02 | 91   | 48278-74 | 93   | 48280-41 | 85   | 48300-42 | 256  | 48371-11 | 291  |
| 47862-77 | 222  | 48039-06 | 159  | 48278-03 | 91   | 48278-75 | 90   | 48280-45 | 84   | 48300-43 | 256  | 48372-08 | 336  |
| 47862-80 | 224  | 48040-00 | 159  | 48278-11 | 92   | 48278-76 | 93   | 48280-46 | 85   | 48306-01 | 326  | 48373-06 | 291  |
| 47862-81 | 224  | 48040-10 | 159  | 48278-12 | 89   | 48278-77 | 90   | 48280-47 | 87   | 48307-01 | 160  | 48373-09 | 291  |
| 47862-82 | 224  | 48040-50 | 159  | 48278-13 | 89   | 48278-81 | 94   | 48280-48 | 84   | 48307-02 | 160  | 48373-12 | 291  |
| 47862-83 | 224  | 48040-AA | 530  | 48278-14 | 94   | 48278-82 | 94   | 48280-49 | 85   | 48307-03 | 160  | 48373-17 | 291  |
| 47862-84 | 224  | 48210-00 | 361  | 48278-15 | 92   | 48278-83 | 94   | 48280-52 | 87   | 48310-14 | 303  | 48501-76 | 166  |
| 47862-85 | 224  | 48211-00 | 361  | 48278-16 | 92   | 48278-84 | 93   | 48280-53 | 87   | 48310-20 | 303  | 48505-01 | 166  |
| 47862-86 | 224  | 48215-14 | 151  | 48278-17 | 91   | 48278-85 | 94   | 48280-54 | 86   | 48311-20 | 303  | 48505-02 | 166  |
| 47862-87 | 224  | 48215-30 | 151  | 48278-18 | 94   | 48278-87 | 90   | 48280-59 | 85   | 48311-25 | 303  | 48505-03 | 166  |
| 47862-88 | 224  | 48218-00 | 115  | 48278-19 | 94   | 48278-88 | 93   | 48280-60 | 87   | 48312-25 | 303  | 48506-01 | 166  |

**NUMERICAL INDEX INDICE NUMERICO NUMERISCH INDEX INDEX NUMERIQUE INDICE NUMERICO**

| Cod.     | pag. | Cod.     | pag. | Cod.     | pag. | Cod.     | pag. | Cod.     | pag. | Cod.     | pag. | Cod.     | pag. |
|----------|------|----------|------|----------|------|----------|------|----------|------|----------|------|----------|------|
| 48506-02 | 166  | 49384-03 | 472  | 49614-28 | 260  | 49655-23 | 252  | 49657-15 | 260  | 49750-00 | 115  | 49829-11 | 118  |
| 48506-03 | 166  | 49384-04 | 472  | 49615-01 | 261  | 49655-24 | 252  | 49657-20 | 260  | 49752-00 | 119  | 49829-BA | 531  |
| 48510-00 | 166  | 49384-05 | 472  | 49616-22 | 260  | 49655-25 | 254  | 49657-25 | 260  | 49753-06 | 119  | 49830-00 | 531  |
| 48511-02 | 167  | 49384-06 | 472  | 49616-24 | 260  | 49655-26 | 254  | 49658-01 | 255  | 49753-09 | 119  | 49830-02 | 531  |
| 48512-02 | 167  | 49384-07 | 472  | 49616-26 | 260  | 49655-27 | 255  | 49658-02 | 256  | 49755-10 | 119  | 49830-60 | 119  |
| 48513-02 | 167  | 49384-11 | 472  | 49616B01 | 261  | 49655-28 | 255  | 49659-24 | 259  | 49760-00 | 113  | 49830-AA | 531  |
| 48514-00 | 166  | 49384-14 | 472  | 49616S01 | 261  | 49655-29 | 253  | 49659-26 | 259  | 49771-00 | 134  | 49830-AB | 531  |
| 48516-07 | 167  | 49384-15 | 472  | 49617-23 | 262  | 49655-30 | 256  | 49660-09 | 258  | 49772-01 | 134  | 49830-AC | 531  |
| 48516-08 | 167  | 49600-00 | 259  | 49617-25 | 262  | 49655-31 | 252  | 49660-13 | 258  | 49773-05 | 134  | 49831-10 | 117  |
| 48516-09 | 167  | 49601-14 | 262  | 49617-30 | 262  | 49655-32 | 252  | 49661-22 | 258  | 49774-05 | 134  | 49832-02 | 117  |
| 48517-03 | 167  | 49602-25 | 259  | 49618-12 | 261  | 49655-34 | 252  | 49661-24 | 258  | 49775-05 | 134  | 49832-10 | 117  |
| 48518-01 | 167  | 49602-30 | 259  | 49618-15 | 261  | 49655-35 | 253  | 49662-40 | 258  | 49775-10 | 134  | 49832-80 | 531  |
| 48518-02 | 167  | 49602-33 | 259  | 49618-18 | 261  | 49655-36 | 252  | 49662-50 | 258  | 49776-15 | 135  | 49832-86 | 531  |
| 48523-01 | 167  | 49602-35 | 259  | 49626-00 | 257  | 49655-37 | 252  | 49663-22 | 258  | 49776-30 | 135  | 49832-88 | 531  |
| 48523-02 | 167  | 49603-15 | 257  | 49626-02 | 257  | 49655-38 | 260  | 49663-24 | 258  | 49777-50 | 134  | 49832-90 | 531  |
| 48523-03 | 167  | 49603-20 | 257  | 49627-22 | 256  | 49655-40 | 259  | 49664-01 | 256  | 49779-15 | 135  | 49832-96 | 531  |
| 48523-04 | 167  | 49603-25 | 257  | 49628-00 | 256  | 49655-41 | 252  | 49664-02 | 256  | 49779-30 | 135  | 49832-98 | 531  |
| 48543-01 | 320  | 49603-30 | 257  | 49629-45 | 262  | 49655-42 | 254  | 49664-03 | 256  | 49790-09 | 452  | 49832-99 | 531  |
| 48543-02 | 320  | 49603-40 | 257  | 49630-06 | 500  | 49655-43 | 254  | 49664-04 | 256  | 49801-04 | 496  | 49833-00 | 421  |
| 49304-06 | 469  | 49603-50 | 257  | 49632-24 | 261  | 49655-44 | 252  | 49664-05 | 256  | 49801-06 | 496  | 49834-00 | 115  |
| 49335-01 | 486  | 49604-31 | 258  | 49632-32 | 261  | 49655-45 | 253  | 49701-00 | 128  | 49802-04 | 496  | 49834-01 | 531  |
| 49335-02 | 486  | 49604-36 | 258  | 49633-22 | 261  | 49655-46 | 252  | 49702-00 | 128  | 49802-06 | 496  | 49834-02 | 531  |
| 49336-00 | 486  | 49604-41 | 258  | 49633-24 | 261  | 49655-49 | 258  | 49703-00 | 131  | 49803-02 | 496  | 49835-00 | 115  |
| 49336-02 | 486  | 49605-46 | 259  | 49634-00 | 262  | 49655-50 | 258  | 49703-01 | 194  | 49806-00 | 497  | 49835-01 | 531  |
| 49337-00 | 486  | 49605-61 | 259  | 49635-00 | 262  | 49655-51 | 254  | 49705-00 | 127  | 49808-00 | 504  | 49835-02 | 531  |
| 49337-01 | 486  | 49605-71 | 259  | 49636-00 | 154  | 49655-52 | 254  | 49709-03 | 22   | 49809-00 | 501  | 49836-00 | 115  |
| 49371-09 | 493  | 49606-00 | 261  | 49637-00 | 262  | 49655-53 | 254  | 49710-00 | 128  | 49811-00 | 125  | 49837-05 | 114  |
| 49371-12 | 493  | 49606-01 | 261  | 49638-00 | 262  | 49655-54 | 254  | 49711-00 | 129  | 49811-01 | 530  | 49837-AA | 531  |
| 49373-01 | 472  | 49606-51 | 261  | 49652-10 | 259  | 49655-55 | 254  | 49712-00 | 127  | 49811-02 | 530  | 49838-08 | 114  |
| 49373-02 | 472  | 49607-15 | 262  | 49652-12 | 259  | 49655-56 | 254  | 49715-00 | 128  | 49812-00 | 125  | 49838-98 | 114  |
| 49373-03 | 472  | 49607-20 | 262  | 49652-15 | 259  | 49655-57 | 254  | 49716-00 | 128  | 49812-01 | 530  | 49838-AB | 532  |
| 49373-04 | 472  | 49607-25 | 262  | 49652-17 | 259  | 49655-58 | 254  | 49717-00 | 129  | 49814-00 | 125  | 49839-00 | 113  |
| 49373-05 | 493  | 49607-30 | 262  | 49652-20 | 259  | 49655-60 | 254  | 49719-00 | 130  | 49814-01 | 530  | 49842-00 | 114  |
| 49373-11 | 472  | 49608-15 | 262  | 49653-10 | 259  | 49655-61 | 255  | 49720-00 | 131  | 49815-00 | 125  | 49843-05 | 123  |
| 49373-12 | 472  | 49608-20 | 262  | 49653-12 | 259  | 49655-64 | 259  | 49721-03 | 131  | 49818-00 | 114  | 49844-01 | 123  |
| 49373-13 | 472  | 49608-25 | 262  | 49653-15 | 259  | 49655-66 | 260  | 49723-00 | 132  | 49818-AC | 114  | 49845-01 | 113  |
| 49373-14 | 472  | 49608-30 | 262  | 49653-17 | 259  | 49655-70 | 254  | 49729-00 | 129  | 49818-AD | 114  | 49846-05 | 450  |
| 49373-90 | 472  | 49608-35 | 262  | 49653-20 | 259  | 49655-72 | 255  | 49730-00 | 131  | 49818-AE | 114  | 49846-09 | 450  |
| 49378-00 | 484  | 49609-12 | 262  | 49654-15 | 259  | 49655-80 | 255  | 49730-20 | 131  | 49818-AF | 114  | 49846-15 | 450  |
| 49378-48 | 493  | 49609-14 | 262  | 49654-20 | 259  | 49655-81 | 255  | 49731-10 | 132  | 49820-05 | 113  | 49847-08 | 452  |
| 49379-00 | 484  | 49610-11 | 262  | 49654-25 | 259  | 49655-86 | 255  | 49731-99 | 131  | 49821-08 | 114  | 49847-38 | 452  |
| 49381-01 | 470  | 49610-14 | 262  | 49655-02 | 257  | 49655-87 | 255  | 49733-00 | 130  | 49823-00 | 119  | 49850-03 | 502  |
| 49381-02 | 472  | 49612-30 | 259  | 49655-03 | 257  | 49655-88 | 255  | 49734-00 | 131  | 49823-89 | 120  | 49850-06 | 500  |
| 49381-03 | 472  | 49612-33 | 259  | 49655-10 | 257  | 49656-02 | 260  | 49735-00 | 131  | 49823-99 | 120  | 49850-10 | 500  |
| 49382-10 | 472  | 49613-30 | 259  | 49655-16 | 257  | 49656-15 | 257  | 49739-00 | 159  | 49827-03 | 120  | 49850-11 | 498  |
| 49382-23 | 472  | 49613-33 | 259  | 49655-21 | 252  | 49656-16 | 257  | 49741-07 | 517  | 49827-77 | 119  | 49850-13 | 498  |
| 49382-47 | 472  | 49613-35 | 259  | 49655-22 | 252  | 49656-20 | 257  | 49741-15 | 517  | 49827-99 | 119  | 49850-14 | 498  |

| Cod.     | pag. | Cod.     | pag. | Cod.     | pag. | Cod.     | pag. | Cod.     | pag. | Cod.     | pag. |
|----------|------|----------|------|----------|------|----------|------|----------|------|----------|------|
| 49850-18 | 497  | 49871-20 | 517  | 49911-30 | 504  | 49942-03 | 505  | 49978-10 | 163  | 66324-50 | 419  |
| 49850-19 | 497  | 49872-00 | 517  | 49911-35 | 504  | 49943-01 | 505  | 49978-13 | 163  | 66324-65 | 419  |
| 49850-20 | 496  | 49875-06 | 159  | 49911-45 | 504  | 49943-02 | 505  | 49979-03 | 501  | 66324-85 | 419  |
| 49850-21 | 497  | 49876-03 | 163  | 49916-25 | 504  | 49944-01 | 505  | 49986-00 | 129  | 66324-99 | 419  |
| 49850-22 | 496  | 49879-37 | 123  | 49916-35 | 504  | 49944-02 | 505  | 49987-00 | 129  | 66325-30 | 419  |
| 49850-23 | 497  | 49879-90 | 532  | 49916-45 | 504  | 49945-05 | 509  | 49988-00 | 129  | 66325-35 | 419  |
| 49850-24 | 502  | 49879-91 | 532  | 49916-55 | 504  | 49946-01 | 506  | 49993-01 | 502  | 66325-41 | 419  |
| 49850-25 | 502  | 49879-92 | 532  | 49921-00 | 515  | 49947-08 | 509  | 49993-02 | 502  | 66325-46 | 419  |
| 49850-26 | 502  | 49879-93 | 532  | 49922-01 | 506  | 49949-09 | 507  | 49993-03 | 502  | 66325-54 | 419  |
| 49850-27 | 502  | 49879-94 | 532  | 49922-02 | 506  | 49949-19 | 500  | 49993-11 | 503  | 66325-85 | 419  |
| 49850-33 | 498  | 49880-10 | 130  | 49922-03 | 506  | 49949-20 | 504  | 49993-12 | 503  | 66325-99 | 419  |
| 49850-36 | 498  | 49880-11 | 130  | 49922-04 | 506  | 49952-08 | 510  | 49993-13 | 503  | 66326-30 | 419  |
| 49850-37 | 499  | 49880-12 | 130  | 49922-06 | 506  | 49953-02 | 501  | 49993-21 | 502  | 66326-35 | 419  |
| 49850-41 | 499  | 49880-13 | 130  | 49922-08 | 507  | 49954-18 | 509  | 49993-22 | 502  | 66326-40 | 419  |
| 49850-42 | 499  | 49880-14 | 130  | 49922-09 | 507  | 49954-20 | 509  | 49993-23 | 502  | 66326-60 | 419  |
| 49850-43 | 500  | 49880-15 | 130  | 49922-20 | 507  | 49954-21 | 508  | 49995-04 | 461  | 66326-80 | 419  |
| 49850-44 | 500  | 49880-17 | 22   | 49922-21 | 507  | 49954-22 | 510  | 49996-00 | 462  | 66339-02 | 279  |
| 49850-61 | 498  | 49881-01 | 130  | 49922-22 | 507  | 49955-01 | 508  | 49996-01 | 462  | 66345-55 | 419  |
| 49850-63 | 501  | 49881-02 | 130  | 49922-23 | 507  | 49956-01 | 508  | 49996-05 | 462  | 66345-65 | 419  |
| 49850-65 | 496  | 49881-11 | 130  | 49923-00 | 315  | 49956-AA | 532  | 49997-12 | 509  | 66345-74 | 419  |
| 49850-70 | 500  | 49881-12 | 130  | 49923-01 | 316  | 49957-00 | 508  | 49997-13 | 509  | 66362-02 | 356  |
| 49850-71 | 497  | 49881-99 | 130  | 49923-02 | 316  | 49958-00 | 507  | 49998-20 | 511  | 66374-00 | 278  |
| 49850-73 | 499  | 49883-00 | 128  | 49923-99 | 316  | 49959-00 | 508  | 49998-35 | 511  | 66391-00 | 278  |
| 49850-75 | 499  | 49884-08 | 129  | 49924-21 | 316  | 49960-00 | 508  | 49999-04 | 442  | 67303-64 | 278  |
| 49850-76 | 499  | 49885-02 | 127  | 49924-31 | 316  | 49971-25 | 163  | 52550F63 | 523  | 67303M01 | 253  |
| 49851-10 | 510  | 49887-00 | 127  | 49924-36 | 316  | 49971M25 | 163  | 52550F73 | 523  | 67303M02 | 253  |
| 49854-03 | 448  | 49887-02 | 128  | 49931-00 | 491  | 49971P25 | 163  | 52550F78 | 523  | 67303M03 | 253  |
| 49854-06 | 449  | 49888-10 | 111  | 49931-60 | 491  | 49971R00 | 163  | 52550F80 | 523  | 67303M04 | 253  |
| 49855-05 | 448  | 49888-20 | 111  | 49931-64 | 491  | 49971R25 | 163  | 52550F88 | 523  | 67303M05 | 253  |
| 49855-10 | 449  | 49889-09 | 109  | 49931-87 | 491  | 49972-30 | 163  | 66303-01 | 277  | 67303M06 | 253  |
| 49855-15 | 449  | 49889-12 | 109  | 49931A00 | 491  | 49972M30 | 163  | 66303-03 | 277  | 67303M07 | 254  |
| 49856-04 | 448  | 49889-15 | 109  | 49931B01 | 491  | 49972P30 | 163  | 66303-06 | 277  | 67303Q80 | 253  |
| 49858-00 | 324  | 49892-40 | 493  | 49931B02 | 491  | 49972R30 | 163  | 66307-06 | 277  | 67303Q81 | 253  |
| 49858-01 | 324  | 49897-09 | 493  | 49931B03 | 491  | 49974-25 | 516  | 66307-09 | 277  | 67303Q82 | 253  |
| 49858-06 | 325  | 49898-30 | 493  | 49931B05 | 491  | 49974-30 | 516  | 66307-12 | 277  | 67303Q83 | 253  |
| 49858-07 | 324  | 49899-01 | 492  | 49931C04 | 491  | 49974U25 | 516  | 66313-03 | 277  | 67305-57 | 253  |
| 49858-AA | 532  | 49899-91 | 492  | 49933-30 | 492  | 49974U30 | 516  | 66313-06 | 278  | 67308-57 | 253  |
| 49860-00 | 325  | 49899-92 | 492  | 49933-50 | 492  | 49975-19 | 515  | 66318-19 | 279  | XO1046   | 532  |
| 49864-03 | 134  | 49899-93 | 492  | 49933-68 | 492  | 49975-22 | 516  | 66318-22 | 279  |          |      |
| 49864-05 | 134  | 49899-94 | 492  | 49934-04 | 492  | 49975-25 | 515  | 66320-28 | 419  |          |      |
| 49864-20 | 134  | 49899-95 | 492  | 49934-06 | 492  | 49975-30 | 516  | 66320-35 | 419  |          |      |
| 49865-06 | 133  | 49899-AA | 532  | 49934-08 | 492  | 49975-35 | 516  | 66320-40 | 419  |          |      |
| 49865-70 | 133  | 49907-01 | 503  | 49934-14 | 493  | 49975U19 | 515  | 66320-50 | 419  |          |      |
| 49867-01 | 125  | 49907-06 | 503  | 49934-16 | 493  | 49975U22 | 516  | 66320-65 | 419  |          |      |
| 49867-02 | 125  | 49907-AA | 504  | 49934-18 | 493  | 49975U25 | 515  | 66320-85 | 419  |          |      |
| 49870-AA | 532  | 49911-19 | 504  | 49940-01 | 504  | 49975U30 | 516  | 66320-99 | 419  |          |      |
| 49871-10 | 517  | 49911-24 | 504  | 49942-01 | 505  | 49975U35 | 516  | 66324-40 | 419  |          |      |

# SALES CONDITIONS

CONDIZIONI DI VENDITA

LIEFERBEDINGUNGEN

CONDITIONS DE VENTE

CONDICIONES DE VENTA



## ENG

### General Sales Terms & Conditions

- All orders are subject to approval and acceptance by Sambonet Paderno Industrie S.p.A.
- Minimum order € 100,00 net.
- Standard packaging included in the price.
- These general sales terms & conditions may be modified only by an agreement in writing.

### Ownership & Payment Terms

- All goods remain the sole property of the Sambonet Paderno Industrie S.p.A. until payment has been made in full.
- Title to the ownership of any delivered good shall be transferred to the client upon full payment of the price set forth in the invoice. Payment becomes due within the payment term agreed upon by the parties. Should any amount to be paid by the client become overdue, the client shall pay a late payment interest pursuant to art. 5 D.L.G.S. 231/2002, as subsequently amended pursuant D.L.G.S. 192/2012, plus an 8% interest rate.

### Offers/Orders

- Any offer of Sambonet Paderno Industrie S.p.A shall not be binding.
- The written acceptance of any offer, or the order confirmation (according to the sales conditions included in it), constitutes a valid purchase order in accordance with the general sales terms & conditions, for all the purposes thereof.

### Returns/Complaints

- Goods must be inspected at the time of delivery.
- Should any good be damaged or defected, the waybill shall be signed with reserve, specifying the relevant reason (pictures of the good displaying the batch number, the courier and a description of the defect must be presented).
- Product returns must be made within 15 days of invoice date, subject to the following conditions:
  - claims and complaints must be made through the guided procedure available on our website, [www.agenti.sambonet.it](http://www.agenti.sambonet.it), under the user section;
  - Goods are delivered ex works - at our premises in Orfengo;
  - in case of customer liability, Sambonet Paderno Industrie S.p.A. will charge 15% of the net value of the goods, with a minimum of € 25.00 for handling charges;
  - in case goods are returned due to our fault, Sambonet Paderno Industrie S.p.A. will replace them free of charge;
  - client will be responsible for all shipping costs for products purchased out of warranty that need to be returned for repairs;
  - customized (not included in our catalogue), Tailor Made engraved, with extra personalization and discontinued items cannot be returned.

### Order Cancellation

- Cancellation is not allowed in case of discontinued, custom designed, and non-stock items.
- Catalogue items can be cancelled only if the purchase order has not yet been confirmed.

### Delivery Terms – Group A

*Austria, Germany, Netherlands, Belgium, Luxembourg, France, UK:*

- Goods are delivered at client's place:
  - with a charge of € 15.00 for orders with a net value between € 100,00 and € 350,00;
  - free of charge for orders with a net value over € 350,00.
- Above delivery terms are valid only for shipments executed through our fixed forwarding agent.

### Delivery Terms – Group B

*Spain, Portugal, Poland, Czech Republic, Slovakia, Hungary, Romania, Slovenia, Croatia, Bulgaria, Denmark, Norway:*

- Goods are delivered at client's place:
  - with a charge of € 30.00 for orders with a net value between € 100,00 and € 600,00;
  - free of charge for orders with a net value over € 600,00.
- Above delivery terms are valid only for shipments executed through our fixed forwarding agent.

### Delivery Terms – Group C

*Greece, Ireland, Latvia, Lithuania, Estonia, Sweden, Finland:*

- Goods are delivered at client's place:
  - with a charge of € 50,00 for orders with a net value between € 100,00 and € 1,000,00;
  - free of charge for orders with a net value over € 1,000,00.
- Above delivery terms are valid only for shipments executed through our fixed forwarding agent.

### Delivery Terms – Group D

*EU and Extra-EU countries not specified in the previous paragraphs:*

- Goods are delivered ex works.

### Personalisations (The costs indicated are net)

- Sambonet Paderno Industrie S.p.A. makes customizations and special executions at the customer's request under the following conditions:
  - advance payment of 30%** on the value of the order;
  - delivery to be agreed after approval of the executive design and/or the sample;
  - Sambonet Paderno Industrie S.p.A. reserves the right to apply a **tolerance** in quantity of +/- 10% (rounded up) for each item ordered;
  - Sambonet Paderno Industrie S.p.A. shall provide the Customer with a form indicating all the necessary parameters (design, position, dimensions, etc.) and shall proceed with the supply only upon receipt of the same signed for acceptance.
- Sawing of fruit knife blades: if not standard, € 0.65 per piece will be charged.
- Pantograph/Laser engraving:
  - plant cost: € 70.00;
  - engraving cost: cutlery € 0.50 per piece – holloware € 1.00 per piece.
  - minimum quantities: cutlery 100 pcs – holloware 10 pcs.
- Stamping:
  - die costs: € 300.00 for the first die - additional dies € 150.00 each;
  - stamping costs: cutlery € 0.50 per piece - holloware will be quoted upon request;
  - minimum quantities:
    - first order: cutlery 1,000 pieces per item - hollow handle knives 800 pieces per item;
    - for further orders: cutlery 100 pieces per item - hollow handle knives 800 pieces per item.

### Sambonet Tailor Made personalizations (The costs indicated are net)

- Type of standard Tailor Made engravings:
  - On the front terminal: one of the standard logos, or the monogram (two letters) using one of the standard characters;
  - On the rear terminal: the date in the standard format, using one of the standard characters;
- Tailor Made engraving cost:
  - € 19.90 for engravings on the front terminal;
  - € 19.90 for engravings on the rear terminal;
  - € 39.80 for engraving on both the front and rear terminals.
- Minimum purchase order for Tailor Made loose items:
  - 6 pcs for nickel-silver items, multiples of 6 pcs;
  - 12 pcs for all other items, multiples of 12 pcs.
- Application of the Tailor Made engraving cost on the single purchase order:
  - A single cost per type of engraving, as set out in point 2;
  - A single cost regardless of the number of pcs, if higher than the minimum purchase indicated in point 3;
  - One cost regardless of the number of pcs up to 150 pcs.
  - Above 150 pcs and at multiples of 150 pcs the cost of engraving will be applied again.

### Special conditions for personalisations

- The Company reserves the right not to carry out the customization if it considers it not technically executable.
- Customized orders and special executions cannot be cancelled.
- Customized products cannot be returned for replacement.
- Requests for specific packaging will be charged to the Customer.

### Marketing

- The goods are intended for marketing in the Country where the customer is based. If the goods are sold in a different Country, the client shall undertake to verify the regulations applicable to the goods in such Country, including customs and import rules, as well as the risk of disputes by third parties for an reason whatsoever. It being understood that the client shall hold Sambonet Paderno Industrie S.p.A. free and harmless of any claim and/or legal action from third parties arising by the sale of the goods in such different Country.
- Sambonet Paderno Industrie S.p.A. does not provide any guarantee regarding possible infringement of intellectual property rights of third parties, in particular in the event of resale of the goods over the internet.
- It is prohibited to publish prices lower than the price lists in force on websites without authentication.

### Retention of title and payment terms

- Any complaints shall not in any case have the effect of deferring or suspending payments.
- Any payment delays shall therefore render the Customer a debtor by law to Sambonet Paderno Industrie S.p.A. of a lump sum indemnity for reminder costs of € 40.00. If the reminder costs exceed the aforementioned amount, Sambonet Paderno Industrie S.p.A. will have the right to claim a further indemnity.
- In the event of non-payment of all or part of the invoice, or of any deterioration in the Customer's financial situation, Sambonet Paderno Industrie S.p.A. will also have the right to:
  - suspend or cancel the orders and deliveries in progress;
  - request advance payment for further orders and/or payment guarantees.

### Delivery

- The delivery deadlines are indicated as accurately as possible but they depend upon the procurement and transportation conditions of Sambonet Paderno Industrie S.p.A., which undertakes to apply the utmost diligence in order to respect the deliveries, subject to causes of force majeure.
- If the planned delivery deadlines are exceeded, Sambonet Paderno Industrie S.p.A. shall not be required to pay any penalty, damages compensation or interest.
- Any change to the order will lead to a consequent change to the delivery date.
- The following are considered to be causes of force majeure, which release Sambonet Paderno Industrie S.p.A. from the delivery obligation: war, revolt, fire, strikes, impossibility of procurement, particularly significant incidents involving equipment, machine breakdowns, interruption or delay in transportation.
- Sambonet Paderno Industrie S.p.A. will keep the Customer informed of any delay. In any case, the delivery within the deadlines may only be made if the Customer has precisely fulfilled all its obligations towards Sambonet Paderno Industrie S.p.A., whatever the cause.
- It is, moreover, agreed between the parties that if the Customer does not take possession of the ordered products under the established conditions, Sambonet Paderno Industrie S.p.A. will invoice to the Customer:
  - any additional transportation and/or storage cost;
  - custody costs equivalent to 5% of the order amount, excluding taxes, for each month of delay.

### Important notice

- The perception of colour may be subjective, in function of geometries, dimensions, finishes, and lighting in the environment. The products subject to PVD processing may manifest slight chromatic variations or diversities between different models, series or batches of the same product. These variations are acceptable if within the established tolerance limits, which are strictly monitored.
- Errors may occur during the printing stage. Sambonet Paderno Industrie S.p.A. reserves the right to correct printing or calculation errors.
- The pictures illustrated and data are representatives. Sambonet Paderno Industrie S.p.A. reserves the right to alter at any time the specifications stated without notice.
- The shapes of cutlery illustrated in this publication are representatives and are not to be considered as the real shape.

**Condizioni Generali e Termini di Vendita**

1. Gli ordini sono soggetti ad approvazione di Sambonet Paderno Industrie S.p.A.
2. Ordine minimo € 100,00 netto merce.
3. Imballo standard gratuito.
4. Qualsiasi variazione delle presenti condizioni richiede la forma scritta.

**Diritto di Proprietà e Condizioni di Pagamento**

1. La merce fornita rimane di proprietà di Sambonet Paderno Industrie S.p.A. fino all'integrale pagamento della fattura da parte del cliente.
2. Il pagamento della fattura è dovuto entro il termine di pagamento preventivamente concordato tra le parti. Allo scadere di tale termine, saranno dovuti gli interessi di mora al saggio di cui all'art.5 D.LGS. 231/2002 e succ. modifiche come da D.LGS. 192/2012, maggiorato dell'8%.

**Offerte/Ordini**

1. Le offerte di Sambonet Paderno Industrie S.p.A. sono libere e non vincolanti all'ordine.
2. Con l'accettazione dell'offerta in forma scritta o della conferma d'ordine (con le modalità in essa contenute), si genera a tutti gli effetti un ordine che comporta l'esecuzione di un contratto conforme alle condizioni generali e termini di vendita.

**Resi/Reclami**

1. La merce deve essere controllata al ricevimento.
2. In caso di colli difettosi/danneggiati, il documento di trasporto dovrà essere firmato con riserva, specificando i motivi (vale come prova la foto del collo con evidenza del segnacollo e nastro del corriere e descrizione del difetto).
3. I reclami saranno accettati entro **15 giorni** dalla data fattura, termine ultimo non negoziabile, alle seguenti condizioni:
  - a) la segnalazione di reclamo / richiesta di reso merce deve essere fatta attraverso la procedura guidata all'indirizzo [www.agenti.sambonet.it](http://www.agenti.sambonet.it) nell'area utente;
  - b) la merce dovrà essere resa franco nostra fabbrica;
  - c) In caso di responsabilità del cliente, Sambonet Paderno Industrie S.p.A. provvederà all'addebito del 15% del prezzo netto, con un minimo di € 25,00, per costi di gestione;
  - d) in caso di accertata responsabilità di Sambonet Paderno Industrie S.p.A., la merce verrà sostituita, e resa franco domicilio cliente;
  - e) per prodotti resi per riparazione non in garanzia, le spese di spedizione e rispedizione, sono a carico del cliente;
  - f) Non saranno accettati resi per articoli speciali (non a catalogo), incisi Tailor Made, con altre personalizzazioni o fuori produzione.

**Annullamento dell'ordine**

1. Per i prodotti fuori catalogo, personalizzati o speciali NON è possibile annullare l'ordine.
2. Per i prodotti a catalogo, l'annullamento è possibile solo se l'ordine non è ancora stato confermato.

**Condizioni di Resa Italia**

1. La merce è resa franco domicilio Cliente tramite corriere convenzionato con Sambonet Paderno Industrie S.p.A.:
  - a) con addebito forfettario di € 15,00 (spese di gestione ordine) per ordini da € 100,00 a € 350,00 netto merce;
  - b) senza alcun addebito per ordini superiori a € 350,00 netto merce.
2. Qualora il Cliente richieda che le spedizioni vengano effettuate tramite Suo corriere di fiducia, le merci verranno inoltrate automaticamente in franco fabbrica:
  - a) con addebito forfettario di € 15,00 (spese di gestione ordine) per ordini da € 100,00 a € 350,00 netto merce;
  - b) senza alcun addebito per ordini superiori a € 350,00 netto merce.
3. Per ogni contestazione o controversia è applicabile la legge Italiana e competente il Foro di Novara.

**Condizioni di Resa – Gruppo A**

*Austria, Germania, Olanda, Belgio, Lussemburgo, Francia, UK:*

1. La merce è resa franco domicilio Cliente:
  - a) con addebito di € 15,00 per ordini da € 100,00 a € 350,00 netto merce;
  - b) senza alcun addebito per ordini superiori a € 350,00 netto merce.
2. Le condizioni sopra indicate sono valide solo per spedizioni tramite corriere convenzionato con Sambonet Paderno Industrie S.p.A.

**Condizioni di Resa – Gruppo B**

*Spagna, Portogallo, Polonia, Repubblica Ceca, Slovacchia, Ungheria, Romania, Slovenia, Croazia, Bulgaria, Danimarca, Norvegia:*

1. La merce è resa franco domicilio Cliente:
  - a) con addebito di € 30,00 per ordini da € 100,00 a € 600,00 netto merce;
  - b) senza alcun addebito per ordini superiori a € 600,00 netto merce.
2. Le condizioni sopra indicate sono valide solo per spedizioni tramite corriere convenzionato con Sambonet Paderno Industrie S.p.A.

**Condizioni di Resa – Gruppo C**

*Grecia, Irlanda, Lettonia, Lituania, Estonia, Svezia, Finlandia:*

1. La merce è resa franco domicilio Cliente:
  - a) con addebito di € 50,00 per ordini da € 100,00 a € 1.000,00 netto merce;
  - b) senza alcun addebito per ordini superiori a € 1.000,00 netto merce.
2. Le condizioni sopra indicate sono valide solo per spedizioni tramite corriere convenzionato con Sambonet Paderno Industrie S.p.A.

**Condizioni di Resa – Gruppo D**

*Nazioni UE ed Extra-UE non specificate nei paragrafi precedenti:*

1. La merce è resa franco fabbrica.

**Personalizzazioni (I costi indicati sono da intendersi netti)**

1. Sambonet Paderno Industrie S.p.A. effettua su richiesta del Cliente personalizzazioni ed esecuzioni particolari alle seguenti condizioni:
  - a) versamento di **acconto del 30%** sul valore dell'ordine;
  - b) consegna da convenire dopo l'approvazione disegno esecutivo e/o campione;
  - c) Sambonet Paderno Industrie S.p.A. si riserva la facoltà di applicare, per ogni singolo articolo, una **tolleranza pari a +/- 10%**, con arrotondamento all'unità superiore, nella spedizione dei quantitativi ordinati;
  - d) Sambonet Paderno Industrie S.p.A. provvederà a fornire al Cliente una scheda con l'indicazione di tutti i parametri necessari (disegno, posizione, dimensioni, ecc.) e procederà alla fornitura solo al ricevimento della stessa firmata per accettazione.
2. Seghettatura lame coltelli frutta: ove non prevista di serie, con addebito di € 0,65 al pezzo.
3. Incisione al Pantografo/Laser:
  - a) costo impianto: € 70,00;
  - b) costo incisione: posateria € 0,50 al pezzo - vasellame, incisione ove possibile, € 1,00 al pezzo;
  - c) quantità minime: posateria 100 pezzi per articolo - vasellame 10 pezzi per articolo.
4. Punzonatura:
  - a) costo punzoni: il primo punzone € 300,00 - i successivi € 150,00 cad.;
  - b) costo punzonatura: posateria € 0,50 al pezzo - vasellame preventivo su richiesta;
  - c) quantità minime:
    - nuovi impianti: posateria 1.000 pezzi per articolo - coltelli manico cavo 800 pezzi per articolo;
    - riordini: posateria 100 pezzi per articolo - coltelli manico cavo 800 pezzi per articolo.

**Personalizzazioni Sambonet Tailor Made (I costi indicati sono da intendersi netti)**

1. Tipologia di incisioni Tailor Made standard:
  - a) Sul terminale frontale: uno dei loghi standard, oppure il monogramma (due lettere) utilizzando uno dei caratteri standard;
  - b) Sul terminale posteriore: la data in formato standard, utilizzando uno dei caratteri standard;
2. Costo di incisione Tailor Made:
  - a) € 19,90 per incisioni sul terminale frontale;
  - b) € 19,90 per incisioni sul terminale posteriore;
  - c) € 39,80 per incisioni sul terminale frontale e sul terminale posteriore.
3. Ordine minimo di acquisto per articoli sfusi Tailor Made:
  - a) 6 pz per le referenze realizzate in alpaca, a multipli di 6 pz;
  - b) 12 pz per tutte le altre referenze, a multipli di 12 pz;
4. Applicazione del costo di incisione Tailor Made sul singolo ordine di acquisto:
  - a) Un solo costo per ogni tipologia di incisione - indicate al punto 2;
  - b) Un solo costo a prescindere dal numero di referenze - se superiori al minimo di acquisto indicato al punto 3;
  - c) Un solo costo a prescindere dal numero di pz fino a 150 pz.
  - d) Oltre i 150 pz e a multipli di 150 pz verrà nuovamente applicato il costo di incisione.

**Condizioni speciali per le personalizzazioni**

1. L'Azienda si riserva il diritto di non eseguire la personalizzazione qualora tecnicamente non eseguibile.
2. Ordini personalizzati e/o esecuzioni particolari non possono essere annullati.
3. I prodotti personalizzati non possono essere resi per sostituzione.
4. Le richieste di imballaggi specifici saranno a carico del Cliente.

**Commercializzazione**

1. La merce è destinata alla commercializzazione nel Paese in cui ha sede il Cliente. Qualora la merce sia commercializzata in un Paese differente, sarà onere del Cliente verificare le normative applicabili in tale Paese incluse le normative doganali e di importazione, nonché il rischio di contestazioni da parte di terzi a qualunque titolo, restando inteso che Sambonet Paderno Industrie S.p.A. sarà manlevata e tenuta indenne dal Cliente per quanto causato dalla vendita della merce in tale diverso Paese.
2. Sambonet Paderno Industrie S.p.A. non fornisce alcuna garanzia in ordine a possibili contestazioni di violazione di diritti di proprietà industriale ed intellettuale di terzi, in particolare nell'ipotesi di rivendita della merce a mezzo Internet.
3. È vietato pubblicare prezzi inferiori ai listini vigenti in siti web senza autenticazione.

**Riserva di proprietà e condizioni di pagamento**

1. Eventuali reclami non potranno in alcun caso avere come effetto il differimento o la sospensione dei pagamenti.
2. Il Cliente in situazioni di ritardo di pagamento sarà peraltro debitore di diritto, nei confronti di Sambonet Paderno Industrie S.p.A. di un indennizzo forfettario per spese di sollecito pari a € 40,00. Qualora le spese di sollecito siano superiori al suddetto importo, Sambonet Paderno Industrie S.p.A. avrà il diritto di richiedere un ulteriore indennizzo.
3. In caso di mancato pagamento di tutta o parte della fattura, o di aggravio della situazione finanziaria del Cliente, Sambonet Paderno Industrie S.p.A. avrà anche la facoltà di:
  - a) sospendere o annullare gli ordini e le consegne in corso;
  - b) esigere un pagamento anticipato per gli ulteriori ordini e/o garanzie di pagamento.

**Consegna**

1. Le scadenze di consegna sono indicate il più esattamente possibile, ma dipendono dalle condizioni di approvvigionamento e trasporto di Sambonet Paderno Industrie S.p.A., la quale si impegna a porre la massima diligenza ai fini del rispetto delle consegne salvo cause di forza maggiore.
2. Il superamento dei tempi di consegna previsti, non potrà vincolare Sambonet Paderno Industrie S.p.A. al versamento di penali, risarcimenti per danni e interessi.
3. Qualsiasi modifica di ordine darà luogo a una conseguente modifica della data di consegna.
4. Sono considerate come cause di forza maggiore, che svincolano Sambonet Paderno Industrie S.p.A. dall'obbligo di consegna: guerra, rivolta, incendio, scioperi, impossibilità di approvvigionamento, incidenti particolarmente rilevanti all'attrezzatura, la rottura di macchine, l'interruzione o il ritardo nel trasporto.
5. Sambonet Paderno Industrie S.p.A. terrà il Cliente tempestivamente informato di qualsiasi ritardo. In ogni caso, la consegna entro i termini potrà essere effettuata soltanto se il Cliente avrà puntualmente ottemperato a tutti i suoi obblighi nei confronti di Sambonet Paderno Industrie S.p.A., qualsiasi sia la causa.
6. Viene peraltro convenuto tra le parti che se il Cliente non prenderà possesso dei prodotti ordinati alle condizioni stabilite, Sambonet Paderno Industrie S.p.A. fatturerà al Cliente:
  - a) qualsiasi ulteriore spesa di trasporto e/o giacenza;
  - b) spese di custodia equivalenti al 5% dell'importo dell'ordine, tasse escluse, per ogni mese di ritardo.

**Avvertenze importanti**

1. La percezione del colore può risultare soggettiva in funzione di geometria, dimensioni, finiture e illuminazione dell'ambiente. I prodotti sottoposti a lavorazione PVD potrebbero essere soggetti a piccole variazioni cromatiche o discontinuità tra diversi modelli, tra diverse referenze o tra partite diverse dello stesso prodotto. Tali variazioni sono comprese entro limiti di tolleranza prestabiliti e strettamente monitorati.
2. In fase di stampa sono possibili errori e/o omissioni. Sambonet Paderno Industrie S.p.A. si riserva il diritto di rettifica di eventuali errori di stampa o calcolo.
3. Le immagini, le caratteristiche e le misure espresse sono indicative e soggette a variazioni senza preavviso.
4. Le sagome delle posate illustrate di questa pubblicazione sono puramente indicative e non si riferiscono alle sagome reali.

# DEU

## Allgemeine Verkaufsbedingungen

1. Bestellungen sind erst nach Bestätigung durch Sambonet Paderno Industrie S.p.A. gültig.
2. **Mindestwarenbestellwert € 100,00 netto.**
3. Standardverpackung kostenlos.
4. Änderungen dieser Bedingungen bedürfen der Schriftform.

## Eigentumsrecht und Zahlungsbedingungen

1. Die gelieferte Ware bleibt bis zur vollständigen Bezahlung der Rechnung durch den Kunden Eigentum der Sambonet Paderno Industrie S.p.A.
2. Die Bezahlung der Rechnung muss innerhalb der zwischen den Parteien zuvor vereinbarten Zahlungsfrist erfolgen. Nach Ablauf dieser Frist werden Verzugszinsen in der in Art. 5 der [italienischen gesetzesvertretenden Verordnung] D. Lgs. 231/2002 (in der durch D. Lgs. 192/2012 geänderten Fassung) vorgesehenen Höhe zuzüglich 8 % fällig.

## Angebote/Bestellungen

1. Angebote von Sambonet Paderno Industrie S.p.A. sind freibleibend.
2. Mit der schriftlichen Annahme des Angebots oder der Auftragsbestätigung (mit allen enthaltenen Bedingungen) wird eine in jeder Hinsicht wirksame Bestellung aufgegeben, die mit der Ausführung eines Vertrags gemäß den allgemeinen Verkaufsbedingungen verbunden ist.

## Rückgaben/Reklamationen

1. Die Ware ist bei Erhalt zu kontrollieren.
2. Sollten Pakete defekt/beschädigt sein, so ist das Transportdokument unter Vorbehalt und mit Angabe der Gründe (z. B. ein Foto der Ware, auf der die Kennzeichnung der Ware und die Spedition erkennbar sind, und eine Beschreibung des Defekts) zu unterschreiben. Reklamationen werden innerhalb von 15 Tagen nach Rechnungsdatum als letzte nicht verhandelbare Frist unter folgenden Bedingungen angenommen:
  - a) Die Reklamation/der Antrag auf Rücknahme der Ware erfolgt über das angeleitete Verfahren im Benutzerbereich der Website [www.agenti.sambonet.it](http://www.agenti.sambonet.it);
  - b) Die Lieferung erfolgt frei unserem Werk;
  - c) Liegt die Verantwortung für die Rückgabe beim Kunden, Sambonet Paderno Industrie S.p.A. stellt 15% des Nettopreises, jedoch mindestens € 25,00 als Bearbeitungskosten in Rechnung;
  - d) Liegt die Verantwortung nachgewiesenermaßen bei Sambonet Paderno Industrie S.p.A., wird die Ware ersetzt und dem Kunden frei Haus zugestellt;
  - e) Im Falle von Produkten, die zur Reparatur zurückgegeben werden und keiner Gewährleistung unterliegen, gehen die Kosten für Zu- und Rücksendung zu Lasten des Kunden;
  - f) Nicht angenommen werden Rücksendungen von Sonderartikeln (nicht im Katalog), kundenindividuellen Artikeln und Artikeln, deren Produktion eingestellt wurde.

## Stornierung der Bestellung

1. Bestellungen von Produkten, die nicht im Katalog enthalten oder die kundenindividuell gefertigt sind, oder Bestellungen von Sonderartikeln können NICHT storniert werden.
2. Bei Produkten aus dem Katalog ist eine Stornierung nur möglich, wenn die Bestellung noch nicht bestätigt wurde.

## Lieferbedingungen – Gruppe A

*Österreich, Deutschland, Holland, Belgien, Luxemburg, Frankreich, Großbritannien:*

1. Die Lieferung zum Kunden erfolgt frei Haus, wobei:
  - a) bei einem Warenbestellwert zwischen € 100,00 und € 350,00 netto eine Pauschale von € 15,00 in Rechnung gestellt wird;
  - b) bei einem Warenbestellwert von über € 350,00 netto keine Versandkosten in Rechnung gestellt werden.
2. Die vorstehenden Bedingungen gelten nur für den Versand mit dem Vertragsspediteur von Sambonet Paderno Industrie S.p.A.

## Lieferbedingungen – Gruppe B

*Spanien, Portugal, Polen, Tschechische Republik, Slowakei, Ungarn, Rumänien, Slowenien, Kroatien, Bulgarien, Dänemark, Norwegen:*

1. Die Lieferung zum Kunden erfolgt frei Haus, wobei:
  - a) bei einem Warenbestellwert zwischen € 100,00 und € 600,00 netto eine Pauschale von € 30,00 in Rechnung gestellt wird;
  - b) bei einem Warenbestellwert von über € 600,00 netto keine Versandkosten in Rechnung gestellt werden.
2. Die vorstehenden Bedingungen gelten nur für den Versand mit dem Vertragsspediteur von Sambonet Paderno Industrie S.p.A.

## Lieferbedingungen – Gruppe C

*Griechenland, Irland, Lettland, Litauen, Estland, Schweden, Finnland:*

1. Die Lieferung zum Kunden erfolgt frei Haus, wobei:
  - a) bei einem Warenbestellwert zwischen € 100,00 und € 1.000,00 netto eine Pauschale von € 50,00 in Rechnung gestellt wird;
  - b) bei einem Warenbestellwert von über € 1.000,00 netto keine Versandkosten in Rechnung gestellt werden.
2. Die vorstehenden Bedingungen gelten nur für den Versand mit dem Vertragsspediteur von Sambonet Paderno Industrie S.p.A.

## Lieferbedingungen – Gruppe D

*EU- und Nicht-EU-Länder, die in den vorherigen Absätzen nicht aufgeführt sind:*

1. Die Lieferung erfolgt frei Werk.

## Kundenindividuelle Anfertigungen (die angegebenen Kosten verstehen sich als Nettobeträge)

1. Auf Wunsch des Kunden stellt Sambonet Paderno Industrie S.p.A. kundenindividuelle und Sonderanfertigungen her. Es gelten die folgenden Bedingungen:
  - a) Es wird eine **Anzahlung in Höhe von 30 %** des Bestellwertes geleistet;
  - b) Die Lieferung wird nach der Freigabe der endgültigen Gestaltung und/oder des Musters vereinbart;
  - c) Sambonet Paderno Industrie S.p.A. behält sich in Bezug auf den Versand der bestellten Mengen für jeden einzelnen Artikel einen **Toleranzwert** von +/- 10 % mit Aufrundung auf die nächsthöhere Einheit vor;
  - d) Sambonet Paderno Industrie S.p.A. legt dem Kunden ein Beschreibungsblatt mit allen erforderlichen Parametern (Zeichnung, Platzierung, Abmessungen usw.) vor. Die Lieferung erfolgt erst, nachdem der Kunde dieses zum Zeichen der Annahme unterschrieben und zurückgesendet hat.
2. Wellenschliff Obstmesser, wenn nicht serienmäßig vorgesehen, Aufpreis von € 0,65 pro Stück.
3. Gravur mit Pantograf/Laser
  - a) Einrichtungskosten: € 70,00;
  - b) Gravurkosten: Besteck € 0,50 pro Stück – Geschirr, sofern Gravur möglich, € 1,00 pro Stück;
  - c) Mindestmengen: Besteck 100 Stück je Artikel – Geschirr 10 Stück je Artikel.
4. Stanzungen:
  - a) Punzen: erste Punze € 300,00 – jede weitere € 150,00;
  - b) Stanzkosten: Besteck € 0,50 pro Stück – Geschirr: bitte Kostenvorschlag anfordern;
  - c) Mindestmengen:
    - Erstbestellung: Besteck 1.000 Stück je Artikel – Messer mit Hohlheftgriff 800 Stück je Artikel;
    - Folgebestellungen: Besteck 100 Stück je Artikel – Messer mit Hohlheftgriff 800 Stück je Artikel.

## Personalisierungen Sambonet Tailor Made (die angegebenen Beträge sind Nettobeträge)

1. Arten Standardgravuren Tailor-Made:
  - a) Auf dem vorderen Ende des Besteckgriffs: eines der Standardlogos, oder das Monogramm (zwei Buchstaben) mit Standardschriftarten;
  - b) Auf dem hinteren Ende des Besteckgriffs: Datum im Standardformat, mit einer Standardschriftart;
2. Kosten der Gravur Tailor-Made:
  - a) € 19,90 für Gravuren auf dem Ende des Besteckgriffs / Vorderseite;
  - b) € 19,90 für Gravuren auf dem Ende des Besteckgriffs / Hinterseite;
  - c) € 39,80 für Gravuren auf dem Ende des Besteckgriffs / Vorder- und Hinterseite.
3. Mindestbestellung für lose Artikel Tailor-Made:
  - a) 6 St. für die Bezugsprofile in Alpacca, in Vielfachstückelungen von 6 St.;
  - b) 12 St. für alle anderen Bezugsprofile, in Vielfachstückelungen von 12 St.;
4. Anwendung der Preise für die Gravur Tailor-Made auf die einzelne Bestellung:
  - a) Nur einmalige Zahlung für jede Art von Gravur – wie in Punkt 2 angeführt;
  - b) Nur einmalige Zahlung unabhängig von der Zahl der Artikel – bei Überschreitung der Mindestbestellung wie in Punkt 3 angeführt;
  - c) Nur einmalige Zahlung unabhängig von der Stückzahl bis zu 150 St.
  - d) bei mehr als 150 St. und Vielfachen von 150 St. werden die Kosten für die Gravur erneut veranschlagt.

## Sonderkonditionen für Personalisierungen

1. Die Firma behält sich das Recht vor die Personalisierung nicht auszuführen, wenn diese technisch nicht durchführbar ist.
2. Bestellungen von kundenindividuellen und/oder nicht standardmäßigen Sonderanfertigungen können nicht storniert werden.
3. Kundenindividuell gefertigte Artikel können nicht umgetauscht werden.
4. Besondere Verpackungsanfragen gehen zu Lasten des Kunden.

## Vertrieb

1. Die Ware ist für die Vermarktung in dem Land, in dem der Kunde ansässig ist, bestimmt. Wenn die Ware in einem anderen Land vermarktet wird, liegt es in der Verantwortung des Kunden, die in diesem Land geltenden Vorschriften einschließlich Zoll- und Einfuhrbestimmungen sowie das Risiko von Streitigkeiten durch Dritte aus irgendeinem Grund zu überprüfen. Es versteht sich, dass Sambonet Paderno Industrie S.p.A. für jede mögliche Streitigkeit, die durch den Verkauf der Ware in diesem anderen Land entstehen kann, schadlos gehalten wird.
2. Sambonet Paderno Industrie S.p.A. übernimmt keine Garantie für eventuelle Ansprüche wegen Verletzung von gewerblichen Schutzrechten und Rechten des geistigen Eigentums Dritter, insbesondere im Falle des Weiterverkaufs der Ware über Internet.
3. Die Veröffentlichung von Preisen, die unter denen der geltenden Preislisten liegen, ist auf Webseiten ohne Authentifizierung verboten.

## Eigentumsvorbehalt und Zahlungskonditionen

1. Eventuelle Beanstandungen können in keinem Fall den Aufschub oder die Unterbrechung der Zahlungen zur Folge haben.
2. Bei Zahlungsverzögerungen ist der Kunde im Übrigen gegenüber Sambonet Paderno Industrie S.p.A. rechtmäßiger Schuldner einer pauschalen Erstattung für Mahnaufwendungen, die sich auf € 40,00 beläuft. Wenn die Mahnaufwendungen den oben genannten Betrag überschreiten, hat Sambonet Paderno Industrie S.p.A. das Recht eine weitere Erstattung einzufordern.
3. Im Falle der Nichtzahlung des vollständigen oder teilweisen Rechnungsbetrags oder einer Verschlechterung der finanziellen Lage des Kunden hat Sambonet Paderno Industrie S.p.A. auch die Befugnis:
  - a) laufende Bestellungen und Lieferungen zu unterbrechen oder zu annullieren;
  - b) eine Vorauszahlung für weitere Bestellungen und/oder Zahlungsverpflichtungen zu verlangen.

## Lieferung

1. Die Liefertermine sind so genau wie möglich angegeben, hängen aber von den Materialbeschaffungs- und Transportbedingungen ab. Sambonet Paderno Industrie S.p.A. bemüht sich aufs Äußerste die Auslieferungstermine einzuhalten. Ausgenommen davon sind Fälle von höherer Gewalt.
2. Die Überschreitung der vorgesehenen Lieferzeiten verpflichtet Sambonet Paderno Industrie S.p.A. nicht zur Zahlung von Straf-, Schadensersatz- und Zinszahlungen.
3. Jede Änderung einer Bestellung hat eine Änderung des Liefertermins zur Folge.
4. Als Fälle von höherer Gewalt und somit als Bedingungen, die Sambonet Paderno Industrie S.p.A. von der Lieferpflicht entbinden, gelten: Krieg, Aufruhr, Brand, Streiks, Unmöglichkeit der Materialbeschaffung, erhebliche Unfälle an den Geräten, der Bruch einer Maschine, die Unterbrechung oder Verspätung des Transports.
5. Sambonet Paderno Industrie S.p.A. informiert den Kunden rechtzeitig über jede Art von Verspätung. In jedem Fall kann die vereinbarte Lieferung nur erfolgen wenn der Kunde alle seine Verpflichtungen gegenüber Sambonet Paderno Industrie S.p.A. pünktlich erfüllt hat und zwar aus welchem Grund auch immer.
6. Darüberhinaus wird zwischen den Parteien vereinbart, dass, wenn der Kunde die bestellten Produkte nicht zu den festgelegten Konditionen entgegen nimmt, Sambonet Paderno Industrie S.p.A. dem Kunden:
  - a) jede weitere Ausgabe für Transport und/oder Einlagerung;
  - b) Aufbewahrungskosten in Höhe von 5% des Betrags der Bestellung, ausschließlich Steuer, für jeden Monat Verspätung in Rechnung stellt.

## Wichtige Hinweise

1. Die Wahrnehmung von Farbe kann subjektiv sein und abhängig von der Geometrie, der Dimension, der Ausführung und der Beleuchtung eines Raums. Produkte, die dem PVD-Verfahren unterzogen werden, können kleine Farbvariationen oder Unterschiede bei verschiedenen Modellen, verschiedenen Referenzen oder Produktionschargen des gleichen Produkts aufweisen. Iese Farbabweichungen befinden sich im Rahmen eines im Voraus festgelegten Toleranzbereiches und werden streng überwacht.
2. Beim Druck kann es zu Fehlern und/oder Auslassungen kommen. Sambonet Paderno Industrie S.p.A. behält sich die Korrektur von Druck- oder Rechenfehlern vor.
3. Fotos und Abmessungen sind nur als Information zu verstehen. Wir behalten uns das Recht vor, die angegebenen Spezifikationen jederzeit zu ändern.
4. Das Profil der Bestecke ist nur als Informationsskizze zu verstehen. Es stellt nicht dar die wirklichen Profile.

# FRA

## Termes et conditions générales de vente

1. Toute commande est soumise à l'acceptation de Sambonet Paderno Industrie S.p.A.
2. Le montant minimum de commande est de € 100,00 net HT.
3. Emballage standard gratuit.
4. Toute modification de ces conditions doit se faire par écrit.

## Droit de propriété et conditions de paiement

1. Les marchandises fournies restent la propriété de Sambonet Paderno Industrie S.p.A. jusqu'au paiement intégral de la facture par le client.
2. La facture doit être réglée dans le délai préalablement convenu entre les parties. Tout retard de paiement entraînera l'application d'intérêts calculés au taux fixé par l'article 5 du décret législatif italien 231/2002 tel que modifié par le décret législatif italien 192/2012, majoré de 8%.

## Offres/ Commandes

1. Les offres de Sambonet Paderno Industrie S.p.A. sont libres et n'engagent pas à passer une commande.
2. L'acceptation d'une offre par écrit, ou la confirmation de la commande (et les manières qui sont contenu), sera réputée une véritable commande, qui entraîne l'exécution d'un contrat conforme aux termes et aux conditions générales de vente.

## Retours/Réclamations

1. Les marchandises doivent être contrôlées à la réception.
2. En cas de colis défectueux / endommagés, le document de transport devra être signé sous réserve, en spécifiant les raisons (la photo du colis avec l'étiquette logistique et le ruban du transporteur bien en évidence, accompagnée de la description du défaut, vaut réserve).
3. Les réclamations doivent être soumises dans un délai maximum non négociable de 15 jours à compter de la date de la facture, aux conditions suivantes:
  - a) la réclamation / la demande de retour de marchandises doit être soumise en suivant la procédure assistée disponible à l'adresse [www.agenti.sambonet.it](http://www.agenti.sambonet.it) dans l'espace utilisateur;
  - b) Tous les retours de marchandises sont départ notre usine;
  - c) en cas de responsabilité du client, Sambonet Paderno Industrie S.p.A. facturera 15% du prix net, avec un montant minimum de € 25,00, pour les frais de gestion;
  - d) en cas de responsabilité avérée de Sambonet Paderno Industrie S.p.A., les marchandises seront remplacées et retournées franco domicile client;
  - e) pour les produits retournés pour réparation hors garantie, les frais de transport aller-retour sont à la charge du client;
  - f) les retours d'articles spéciaux (hors catalogue), personnalisés ou hors production ne sont pas acceptés.

## Annulation des commandes

1. Les commandes de produits hors catalogue, personnalisés ou spéciaux ne peuvent pas être annulées.
2. Les commandes de produits sur catalogue ne peuvent être annulées que si la commande n'a pas encore été confirmée.

## Conditions de livraison – Groupe A

*Autriche, Allemagne, Pays-Bas, Belgique, Luxembourg, France, Royaume-Uni:*

1. Les envois de marchandises sont franco domicile client:
  - a) avec € 15,00 à la charge du client pour tout montant net HT de commande de € 100,00 à € 350,00;
  - b) sans aucune charge pour tout montant net HT de commande supérieur à € 350,00.
2. Les conditions susmentionnées ne sont valables que pour les envois effectués par le transporteur conventionné avec Sambonet Paderno Industrie S.p.A.

## Conditions de livraison – Groupe B

*Espagne, Portugal, Pologne, République tchèque, Slovaquie, Hongrie, Roumanie, Slovaquie, Croatie, Bulgarie, Danemark, Norvège:*

1. Les envois de marchandises sont franco domicile client:
  - a) avec € 30,00 à la charge du client pour tout montant net HT de commande de € 100,00 à € 600,00;
  - b) sans aucune charge pour tout montant net HT de commande supérieur à € 600,00.
2. Les conditions susmentionnées ne sont valables que pour les envois effectués par le transporteur conventionné avec Sambonet Paderno Industrie S.p.A.

## Conditions de livraison – Groupe C

*Grèce, Irlande, Lettonie, Lituanie, Estonie, Suède, Finlande:*

1. Les envois de marchandises sont franco domicile client:
  - a) avec € 50,00 à la charge du client pour tout montant net HT de commande de € 100,00 à € 1.000,00;
  - b) sans aucune charge pour tout montant net HT de commande supérieur à € 1.000,00.
2. Les conditions susmentionnées ne sont valables que pour les envois effectués par le transporteur conventionné avec Sambonet Paderno Industrie S.p.A.

## Conditions de livraison – Groupe D

*Pays de l'UE et extra-UE non spécifiés dans les paragraphes précédents:*

1. Tous les envois de marchandises sont départ usine.

## Produits personnalisés (Les prix indiqués sont nets)

1. Sambonet Paderno Industrie S.p.A. est en mesure de réaliser des produits personnalisés à la demande du client aux conditions suivantes:
  - a) paiement d'un acompte de 30% sur le montant de la commande;
  - b) livraison à convenir après l'approbation du dessin exécutif et/ou de l'échantillon;
  - c) Sambonet Paderno Industrie S.p.A. se réserve le droit d'appliquer à chaque référence une tolérance de livraison sur les quantités commandées de +/- 10% arrondie à l'unité supérieure;
  - d) Sambonet Paderno Industrie S.p.A. enverra au client une fiche avec toutes les données techniques nécessaires (dessin, position, dimensions, etc.) et n'exécutera la commande qu'à la réception de la fiche signée pour autorisation.
2. Couteaux à dessert exécutés avec lame dentelée (si cette lame n'est pas la lame standard): € 0,65 par pièce.
3. Gravure pantographe/laser:
  - a) frais de commande: € 70,00;
  - b) frais de gravure: couverts € 0,50 par pièce - plats et articles de table, si gravure faisable, € 1,00 par pièce;
  - c) quantité minimum de commande: couverts 100 pièces pour chaque référence - plats et articles de table 10 pièces pour chaque référence.
4. Poinçonnage:
  - a) frais de poinçon: € 300,00 pour le premier poinçon - € 150,00 pour chaque poinçon supplémentaire;
  - b) frais de poinçonnage: couverts € 0,50 par pièce - plats et articles de table: devis sur demande;
  - c) quantité minimum de commande:
    - première commande: couverts 1.000 pièces par référence - couteaux poignée creuse 800 pièces par référence;
    - commandes suivantes: couverts 100 pièces par référence - couteaux poignée creuse 800 pièces par référence.

## Personnalisations Sambonet Tailor Made (Les prix indiqués sont nets)

1. Types de gravures Tailor Made standard :
  - a) Au recto du manche : un des logos standard ou un monogramme (deux lettres) en utilisant l'une des polices standard ;
  - b) Au verso du manche : la date au format standard en utilisant l'une des polices standard ;
2. Coût de la gravure Tailor Made :
  - a) 19,90 € pour les gravures au recto du manche ;
  - b) 19,90 € pour les gravures au verso du manche ;
  - c) 39,80 € pour les gravures au recto et au verso du manche.
3. Minimum d'achat pour des articles en vrac Tailor Made :
  - a) 6 pièces pour les références en maillechort, par multiple de 6 pièces ;
  - b) 12 pièces pour toutes les autres références, par multiple de 12 pièces ;
4. Application du coût de la gravure Tailor Made sur chaque commande :
  - a) Un coût unique pour chaque type de gravure – indiqués au point 2 ;
  - b) Un coût unique quel que soit le nombre de références – à condition qu'il soit supérieur au minimum d'achat indiqué au point 3 ;
  - c) Un coût unique quel que soit le nombre de pièces jusqu'à 150 pièces.
  - d) Au-delà de 150 pièces et par multiple de 150 pièces, le coût de la gravure sera à nouveau appliqué.

## Conditions spéciales pour les personnalisations

1. L'entreprise se réserve le droit de ne pas procéder à la personnalisation pour des raisons de faisabilité technique.
2. Les commandes de produits personnalisés e/o spéciaux ne peuvent pas être annulées.
3. Les produits personnalisés ne peuvent pas être retournés pour remplacement.
4. Toute demande d'emballage spécifique est à la charge du Client.

## Commercialisation

1. Les produits sont destinés à la commercialisation dans le Pays où le client est basé. Si les produits sont vendus dans un autre Pays, il est de la responsabilité du client de vérifier les réglementations applicables dans ce Pays, y compris les réglementations douanières et d'importation, ainsi que le risque de litiges par des tiers pour quelque motif que ce soit, étant entendu que Sambonet Paderno Industrie S.p.A. sera déchargé de tout litige qui pourrait survenir dans ce Pays différent.
2. Sambonet Paderno Industrie S.p.A. ne fournit aucune garantie quant à d'éventuelles actions pour violation des droits de propriété industrielle et intellectuelle par des tiers, en particulier en cas de revente du produit sur Internet.
3. Il est interdit de publier des prix inférieurs aux tarifs en vigueur sur des sites Web sans authentification.

## Réserve de propriété et conditions de paiement

1. Toute réclamation du Client ne peut en aucun cas avoir pour effet de différer ou de suspendre le paiement.
2. En cas de retard de paiement, le Client est redevable de plein droit, envers Sambonet Paderno Industrie S.p.A., d'une indemnité forfaitaire de 40,00 € pour frais de recouvrement. Si les frais de recouvrement sont supérieurs à ce montant, Sambonet Paderno Industrie S.p.A. est en droit de réclamer une indemnisation complémentaire.
3. En cas de non-paiement de tout ou partie de la facture, ou en cas de dégradation de la situation financière du Client, Sambonet Paderno Industrie S.p.A. a également le droit de :
  - a) suspendre ou annuler toute commande et livraison en cours ;
  - b) exiger un acompte pour toute nouvelle commande et/ou des garanties de paiement.

## Livraison

1. Les délais de livraison sont indiqués aussi exactement que possible, mais sont fonction des possibilités d'approvisionnement et de transport de Sambonet Paderno Industrie S.p.A., qui s'engage à respecter les délais de livraison avec la plus grande rigueur sauf cas de force majeure.
2. Les dépassements de délai de livraison ne peuvent donner lieu au paiement de pénalités et de dommages-intérêts par Sambonet Paderno Industrie S.p.A.
3. Toute modification de la commande entraînera une modification de la date de livraison.
4. Sont considérés comme cas de force majeure déchargeant Sambonet Paderno Industrie S.p.A. de son obligation de livrer : la guerre, l'émeute, l'incendie, les grèves, l'impossibilité d'être approvisionné, les accidents graves de matériel, les pannes de machines, l'interruption ou le retard dans les transports.
5. Sambonet Paderno Industrie S.p.A. s'engage à informer le Client sans délai de tout retard. En toute hypothèse, la livraison dans les délais ne peut intervenir que si le Client est à jour de ses obligations envers Sambonet Paderno Industrie S.p.A., quelle qu'en soit la cause.
6. Les parties conviennent également que si le Client ne prend pas possession des produits commandés selon les conditions fixées, Sambonet Paderno Industrie S.p.A. lui facturera :
  - a) les frais supplémentaires de transport et/ou de stockage ;
  - b) les frais de garde équivalents à 5 % du montant de la commande, hors taxes, pour chaque mois de retard.

## Avertissements importants

1. La perception de la couleur peut être subjective en fonction de la géométrie, des dimensions, des finitions et de l'éclairage du local. Les produits soumis à un traitement PVD pourraient subir de petites variations chromatiques ou des discontinuités parmi des modèles, des références ou des lots différents du même produit. Ces variations sont comprises dans les limites de tolérance préétablies et strictement surveillées.
2. Des fautes et/ou des omissions peuvent survenir lors de l'impression. Sambonet Paderno Industrie S.p.A. se réserve le droit de corriger toute faute d'impression ou de calcul.
3. Les photos et dimensions indiquées sont indicatives. Sambonet Paderno Industrie S.p.A. se réserve le droit de modifier à tout moment les spécifications techniques.
4. Les silhouettes des couverts de ce tarif sont uniquement indicatives et elles ne se réfèrent pas à la silhouette réelle des couverts.



## ESP

### Condiciones generales y de venta

1. Los pedidos deben ser aprobados por Sambonet Paderno Industrie S.p.A.
2. Pedido mínimo de € 100,00 en factura.
3. Embalaje estándar incluido.
4. Cualquier variación de las presentes condiciones debe realizarse por escrito.

### Derecho de propiedad y condiciones de pago

1. La mercancía queda de propiedad de Sambonet Paderno Industrie S.p.A. hasta que el cliente realice el pago total de la factura.
2. El plazo de pago de la factura debe realizarse dentro de los términos establecidos previamente por las partes. Al caducar dicho plazo, deberán considerarse los intereses de demora según lo dispuesto por el art. 5 D.LGS 231/2002 y siguientes modificaciones, como previsto en el D.LGS. 192/2012, con aumento del 8%.

### Ofertas/Pedidos

1. Las ofertas de Sambonet Paderno Industrie S.p.A. son libres y no vinculantes al pedido.
2. Aceptando por escrito la oferta, o de la confirmación del pedido (con la modalidad en ella incluidas) se produce a todos los efectos un pedido que implica un contrato conforme a las condiciones generales y de venta.

### Restituciones/Reclamaciones

1. La mercancía debe controlarse en el momento de la entrega.
2. En caso de embalajes defectuosos/deteriorados, el documento de transporte se deberá firmar bajo reserva especificando las razones (como reserva se debe presentar la foto del embalaje y su código de barra, la cinta del servicio de transporte y la descripción de la avería).
3. Las reclamaciones se aceptarán dentro de **15 días** a partir de la fecha de emisión de la factura, plazo no negociable, bajo las condiciones que se citan a continuación:
  - a) La reclamación/solicitud de restitución de mercancía debe realizarse a través del procedimiento guiado en la página web: [www.agenti.sambonet.it](http://www.agenti.sambonet.it) en el área de usuarios;
  - b) La mercancía se entrega franco nuestra fábrica;
  - c) En caso de que el cliente sea responsable, Sambonet Paderno Industrie S.p.A. le cargará el 15% del precio neto, con un mínimo de € 25,00 de coste de gestión;
  - d) en caso de responsabilidad comprobada de Sambonet Paderno Industrie S.p.A., la mercancía será reemplazada y entregada al cliente con porte pagado;
  - e) los gastos de transporte para la reparación de productos sin garantía, corren a cargo del cliente;
  - f) para los artículos especiales (no incluidos en el catálogo), personalizados o fuera de producción no será posible restituir la mercancía.

### Cancelación del pedido

- a) para los productos no incluidos en el catálogo, personalizados o especiales NO es posible cancelar el pedido.
- b) para los productos incluidos en el catálogo, es posible cancelar el pedido sólo en caso de que aún no haya sido confirmado.

### Condiciones de entrega – Grupo A

*Austria, Alemania, Holanda, Bélgica, Luxemburgo, Francia, Reino Unido:*

1. La mercancía se remite a porte pagado:
  - a) cargando € 15,00 para pedidos de entre € 100,00 y € 350,00 netos;
  - b) sin cargo alguno si el pedido neto sobrepasa los € 350,00.
2. Las condiciones mencionadas arriba deben considerarse válidas sólo para los servicios de transporte elegidos por Sambonet Paderno Industrie S.p.A.

### Condiciones de entrega – Grupo B

*España, Portugal, Polonia, República Checa, Eslovaquia, Hungría, Rumania, Eslovenia, Croacia, Bulgaria, Dinamarca, Noruega:*

1. La mercancía se remite a porte pagado:
  - a) cargando € 30,00 para pedidos de entre € 100,00 y € 600,00 netos;
  - b) sin cargo alguno si el pedido neto sobrepasa los € 600,00.
2. Las condiciones mencionadas arriba deben considerarse válidas sólo para los servicios de transporte elegidos por Sambonet Paderno Industrie S.p.A.

### Condiciones de entrega – Grupo C

*Grecia, Irlanda, Letonia, Lituania, Estonia, Suecia, Finlandia:*

1. La mercancía se remite a porte pagado:
  - a) cargando € 50,00 para pedidos de entre € 100,00 y € 1.000,00 netos;
  - b) sin cargo alguno si el pedido neto sobrepasa los € 1.000,00.
2. Las condiciones mencionadas arriba deben considerarse válidas sólo para los servicios de transporte elegidos por Sambonet Paderno Industrie S.p.A.

### Condiciones de entrega – Grupo D

*Países de la UE y países extra-UE no especificados en los párrafos anteriores:*

1. La mercancía se entrega franco fábrica.

### Personalizaciones (Los precios indicados deben considerarse netos)

1. Bajo solicitud del cliente, Sambonet Paderno Industrie S.p.A. realiza personalizaciones y acabados particulares según las siguientes condiciones:
  - a) pago de un anticipo del 30% del valor del pedido;
  - b) La entrega será establecida tras aprobar el diseño ejecutivo y/o la muestra;
  - c) Sambonet Paderno Industrie S.p.A. se reserva el derecho de aplicar, en cada artículo, una tolerancia del +/- 10%, redondeando por exceso, para el envío de las cantidades solicitadas;
  - d) Sambonet Paderno Industrie S.p.A. enviará al cliente una ficha con toda la información necesaria (diseño, posición, medidas, ecc). La entrega se efectuará sólo después de haber recibido la ficha firmada por el cliente.
2. Endentado de hojas cuchillos postre: si no previsto de serie, con cargo de € 0,65 / pieza.
3. Grabado por Pantógrafo/Láser:
  - a) coste instalación: € 70,00;
  - b) coste grabado: cubiertos € 0,50 / pieza – vajilla, grabado (si es posible) € 1,00 / pieza;
  - c) cantidades mínimas. Cubiertos: 100 piezas por modelo – vajilla: 10 piezas por modelo.
4. Punzonado:
  - a) coste punzones: € 300,00 para el primer punzón – € 150,00 para los siguientes (cada uno);
  - b) coste punzonado: cubiertos € 0,50 / pieza – vajilla: solicitando un presupuesto;
  - c) pedidos mínimos:
    - nuevas instalaciones. Cubiertos: 1.000 piezas por modelo – cuchillos de mango hueco: 800 piezas por modelo;
    - pedidos adicionales. Cubiertos: 100 piezas por modelo – cuchillos de mango hueco: 800 piezas por modelo.

### Personalizaciones Sambonet Tailor Made (Los costes indicados son netos)

1. Tipos de grabados Tailor Made estándar:
  - a) En el terminal frontal: uno de los logotipos estándar, o el monograma (dos letras) usando uno de los caracteres estándar;
  - b) En el terminal trasero: la fecha en formato estándar, utilizando uno de los caracteres estándar;
2. Coste de grabado Tailor Made:
  - a) € 19,90 para grabados en el terminal frontal;
  - b) € 19,90 para grabados en el terminal trasero;
  - c) € 39,80 para grabados en el terminal delantero y en el terminal trasero.
3. Pedido mínimo de compra para artículos sueltos Tailor Made:
  - a) 6 pzas para las referencias hechas en alpaca, con múltiples de 6 pzas;
  - b) 12 pzas para todas las otras referencias, con múltiples de 12 pzas;
4. Aplicación del coste de grabado Tailor Made en un único pedido de compra:
  - a) Un solo coste para cada tipo de grabado - indicados en el punto 2;
  - b) Un solo coste independientemente del número de referencias - si superiores al mínimo de compra indicado en el punto 3;
  - c) Un solo coste independientemente del número de pzas hasta 150 pzas.
  - d) Con más de 150 pzas y múltiples de 150 pzas se aplicará otra vez el coste de grabado.

### Condiciones especiales para las personalizaciones

1. La Empresa se reserva el derecho de no llevar a cabo la personalización si no fuera técnicamente realizable.
2. Pedidos personalizados y/o acabados particulares no se pueden cancelar.
3. No se pueden devolver, para su reemplazo, los productos personalizados.
4. Las solicitudes de embalajes específicos correrán a cargo del Cliente.

### Comercialización

1. Los productos están destinados a la comercialización en el País donde se encuentra el cliente. Si los productos se comercializan en un País diferente, será responsabilidad del cliente verificar las regulaciones aplicables en ese País, incluidas las regulaciones de aduanas e importación, así como el riesgo de disputas por parte de terceros por cualquier motivo, entendiéndose que Sambonet Paderno Industrie SpA estará libre de cualquier disputa que pueda surgir en este País diferente.
2. Sambonet Paderno Industrie S.p.A. no ofrece ninguna garantía con respecto a posibles reclamos de violación de derechos de propiedad industrial e intelectual de terceros, en particular en el caso de reventa de los productos a través de Internet.
3. Está prohibido publicar precios inferiores a las listas de precios vigentes en sitios web sin autenticación.

### Reserva de propiedad y condiciones de pago

1. Cualquier reclamación no podrá, en ningún caso, tener como efecto el retraso o la suspensión de los pagos.
2. Además, en situaciones de retraso en el pago, el Cliente será deudor de derecho, para con Sambonet Paderno Industrie S.p.A. de una indemnización a tanto alzado por los gastos de requerimiento igual a € 40,00. Si los gastos de requerimiento son más altos que la cantidad mencionada anteriormente, Sambonet Paderno Industrie S.p.A. tendrá derecho a solicitar una compensación adicional.
3. En caso de falta de pago de toda o parte de la factura, o de empeoramiento de la situación financiera del Cliente, Sambonet Paderno Industrie S.p.A. también tendrá el derecho de:
  - a) suspender o cancelar los pedidos y las entregas en curso;
  - b) exigir un pago por adelantado para los pedidos y/o garantías de pago sucesivos.

### Entrega

1. Los plazos de entrega se indican lo más exactamente posible, pero dependen de las condiciones de abastecimiento y transporte de Sambonet Paderno Industrie S.p.A., que se compromete a poner la máxima diligencia para cumplir con las entregas, excepto en casos de fuerza mayor.
2. Exceder los tiempos de entrega previstos no puede vincular Sambonet Paderno Industrie S.p.A. al pago de sanciones o indemnizaciones por daños e intereses.
3. Cualquier modificación del pedido dará lugar a una consecuente modificación de la fecha de entrega.
4. Se consideran causas de fuerza mayor que liberan Sambonet Paderno Industrie S.p.A. de la obligación de la entrega: guerra, revuelta, incendio, huelgas, imposibilidad de abastecimiento, accidentes especialmente relevantes al equipo de fabricación, la rotura de máquinas, la interrupción o el retraso en el transporte.
5. Sambonet Paderno Industrie S.p.A. informará al Cliente de forma tempestiva sobre cualquier retraso. En cualquier caso, la entrega dentro de los plazos solo se puede realizar si el Cliente ha cumplido debidamente con todas sus obligaciones para con Sambonet Paderno Industrie S.p.A., cualquiera sea la causa.
6. También se acuerda entre las partes que si el Cliente no toma posesión de los productos pedidos bajo las condiciones establecidas, Sambonet Paderno Industrie S.p.A. facturará al Cliente:
  - a) cualquier costo adicional de transporte y/o almacenamiento;
  - b) gastos de custodia equivalentes al 5% del monto del pedido, excluidos los impuestos, para cada mes de retraso.

### Advertencias importantes

1. La percepción del color puede ser subjetiva en función de la geometría, el tamaño, los acabados y la iluminación del entorno. Los productos sometidos al proceso PVD podrían estar sujetos a pequeñas variaciones cromáticas o discontinuidades entre diferentes modelos, entre diferentes referencias o entre partidas diferentes del mismo producto. Dichas variaciones están comprendidas dentro de límites de tolerancia preestablecidos y estrictamente monitoreados.
2. Al imprimir puede que surjan errores y/o omisiones. Sambonet Paderno Industrie S.p.A. se reserva el derecho a rectificar eventuales errores de impresión o de cálculo.
3. Fotos, datos y medidas que aparecen en este catálogo son indicativos y susceptibles, sin previo aviso, de modificación.
4. Los perfiles de los cubiertos de la lista de precios son meramente simbólicos y no corresponden a los perfiles reales.



## CREDITS

### PHOTO - FOTO

**Riccardo Bianchi**  
**Felice Scoccimarro**

### LOCATIONS

**Ristorante Dolce Stil Novo Alla Reggia, Venaria Reale – Torino, Italia**  
**Ristorante I Gemelli – Milano, Italia**

### COVER - IN COPERTINA

**Alfredo Russo – Michelin-starred chef**

### PRINT - STAMPA

**Graphicscalve S.p.A.**

MEMBER  
OF 

**ARCTURUS** GROUP

### © COPYRIGHT

- Ogni riproduzione anche parziale del presente catalogo è vietata se non espressamente autorizzata per iscritto da Sambonet Paderno Industrie S.p.A.
- This catalogue may not be reproduced in whole or in part unless specific prior written authorization of Sambonet Paderno Industrie S.p.A.
- Die Vervielfältigung dieses Katalogs -auch wenn partial- ohne unsere ausdrückliche schriftliche Erlaubnis ist untersagt.
- Toute reproduction ou reproduction partielle de ce catalogue est interdite sauf expressément autorisée par Sambonet Paderno Industrie S.p.A.
- Queda prohibida la reproducción total o parcial de este catálogo sin autorización de forma expresa y por escrito de Sambonet Paderno Industrie S.p.A.

### NOTE - NOTES

- Le misure, caratteristiche ed illustrazioni dei prodotti sono indicative e soggette a variazioni senza preavviso qualora esigenze tecnico produttive lo richiedessero.
- The pictures illustrated and data are representatives. We reserve the right to alter at any time the specifications stated without notice, whenever technical requirements shall so demand.
- Fotos und Abmessungen sind nur als information zu verstehen. Wir behalten uns das Recht vor, die angegebenen Spezifikationen jederzeit zu ändern, sofern es aus produktionstechnischen Gründen erforderlich ist.
- Les photos et dimensions indiquées sont indicatives. Nous nous réservons le droit de modifier à tout moment les spécifications techniques, si la situation l'exige.
- Fotos, datos y medidas que aparecen en este catálogo son indicativos y susceptibles, sin previo aviso, de modificación por exigencias técnicas o de producción.







**SAMBONET PADERNO INDUSTRIE S.P.A.**

Via Giovanni Coppo 1,C - 28060 Orfengo (NO) - Italy

Ph. +39 0321 1916 601

Fax +39 0321 1916 890

[horeca@paderno.it](mailto:horeca@paderno.it)

[www.paderno.it](http://www.paderno.it)

**ROSENTHAL SAMBONET USA LTD.**

685 Route 10 - Randolph NJ 07869 - USA

Ph. +1 201 804 8000

Fax +1 201 842 9195

[info@rosenthalusa.com](mailto:info@rosenthalusa.com)

[www.rosenthal-hotel-restaurant.com](http://www.rosenthal-hotel-restaurant.com)

MEMBER  
OF   
ARCTURUS GROUP

XA1002 - Ed. 7/2021

